



CAT660

100mA CMOS Charge Pump Inverter/Doubler

FEATURES

- Replaces MAX660 and LTC®660
- Converts V+ to V- or V+ to 2V+
- Low output resistance, 4Ω typical
- High power efficiency
- Selectable charge pump frequency
 - 10kHz or 80kHz
 - Optimize capacitor size
- Low quiescent current
- Pin-compatible, high-current alternative to 7660/1044
- Industrial temperature range
- Available in 8-pin SOIC, DIP and 0.8mm thin 8-pad TDFN packages
 - Lead-free, halogen-free package option

APPLICATIONS

- Negative voltage generator
- Voltage doubler
- Voltage splitter
- Low EMI power source
- GaAs FET biasing
- Lithium battery power supply
- Instrumentation
- LCD contrast bias
- Cellular phones, pagers

DESCRIPTION

The CAT660 is a charge-pump voltage converter. It will invert a 1.5V to 5.5V input to a -1.5V to -5.5V output. Only two external capacitors are needed. With a guaranteed 100mA output current capability, the CAT660 can replace a switching regulator and its inductor. Lower EMI is achieved due to the absence of an inductor.

In addition, the CAT660 can double a voltage supplied from a battery or power supply. Inputs from 2.5V to 5.5V will yield a doubled, 5V to 11V output voltage.

A Frequency Control pin (BOOST/FC) is provided to select either a high (80kHz) or low (10kHz) internal oscillator frequency, thus allowing quiescent current vs. capacitor size trade-offs to be made. The 80kHz frequency is selected when the FC pin is connected to

V+. The operating frequency can also be adjusted with an external capacitor at the OSC pin or by driving OSC with an external clock.

Both 8-pin DIP and SOIC packages are available in the industrial temperature range. The TDFN package has a 4x4mm footprint and features a 0.8mm maximum height. Compared to the 8-pin SOIC the TDFN package footprint is nearly 50% less. For die availability, contact Catalyst Semiconductor marketing.

The CAT660 replaces the MAX660 and the LTC®660. In addition, the CAT660 is pin compatible with the 7660/1044, offering an easy upgrade for applications with 100mA loads.

TYPICAL APPLICATION

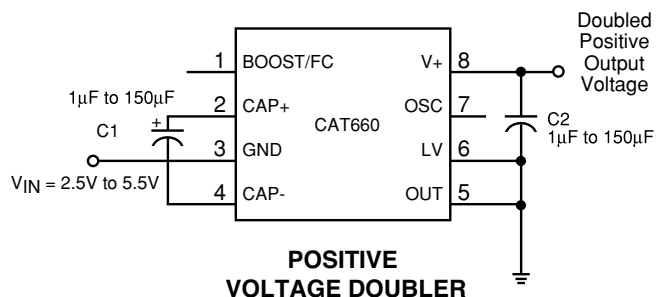
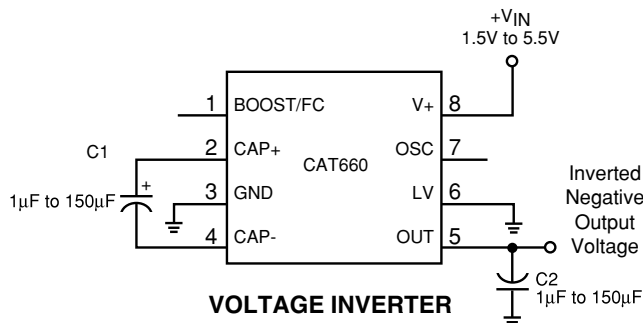

PIN CONFIGURATION

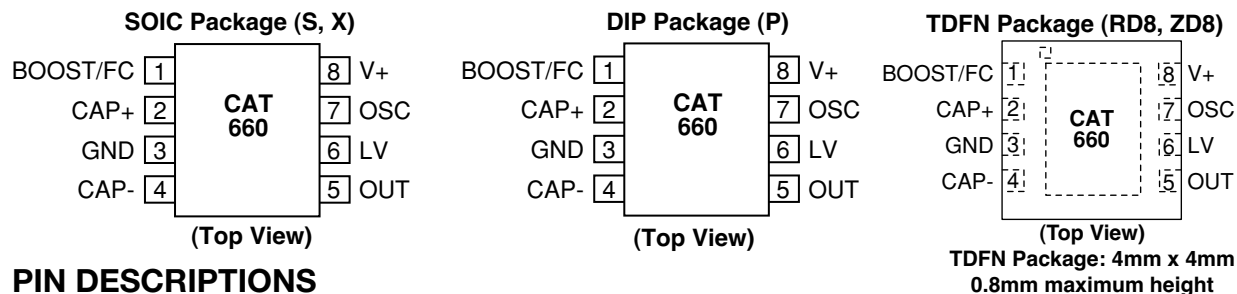

PIN DESCRIPTIONS

		Circuit Configuration	
Pin Number	Name	Inverter Mode	Doubler Mode
1	Boost/FC	Frequency Control for the internal oscillator. With an external oscillator BOOST/FC has no effect.	
		Boost/FC	Oscillator Frequency
		Open	10kHz typical, 5kHz minimum
		V+	80kHz typical, 40kHz minimum
2	CAP+	Charge pump capacitor. Positive terminal.	Same as inverter.
3	GND	Power supply ground.	Power supply. Positive voltage input.
4	CAP-	Charge pump capacitor. Negative terminal.	Same as inverter.
5	OUT	Output for negative voltage.	Power supply ground.
6	LV	Low-Voltage selection pin. When the input voltage is less than 3V, connect LV to GND. For input voltages above 3V, LV may be connected to GND or left open. If OSC is driven externally, connect LV to GND.	LV must be tied to OUT for all input voltages.
7	OSC	Oscillator control input. An external capacitor can be connected to lower the oscillator frequency. An external oscillator can drive OSC and set the chip operating frequency. The charge-pump frequency is one-half the frequency at OSC.	Same as inverter. Do not overdrive OSC in doubling mode. Standard logic levels will not be suitable. See the applications section for additional information.
8	V+	Power supply. Positive voltage input.	Positive voltage output.

ORDERING INFORMATION

Part Number	Package	Temperature Range
CAT660EPA	8 lead Plastic DIP	-40°C to 85°C
CAT660ESA	8-lead SOIC	-40°C to 85°C
CAT660ESA-TE13	8-lead SOIC, Tape & Reel	-40°C to 85°C
CAT660ERD8	8-pad TDFN	-40°C to 85°C
CAT660EVA	8-lead SOIC (Lead-free, Halogen-free)	-40°C to 85°C
CAT660EVA-TE13	8-lead SOIC (Lead-free, Halogen-free)	-40°C to 85°C
CAT660EZD8	8-pad TDFN (Lead-free, Halogen-free)	-40°C to 85°C

ABSOLUTE MAXIMUM RATINGS

V+ to GND 6V

Input Voltage (Pins 1, 6 and 7) .. -0.3V to (V+ + 0.3V)

BOOST/FC and OSC Input Voltage The least negative of (Out - 0.3V) or (V+ - 6V) to (V+ + 0.3V)

Output Short-circuit Duration to GND 1 sec.

(OUT may be shorted to GND for 1 sec without damage but shorting OUT to V+ should be avoided.)

Continuous Power Dissipation (T_A = 70°C)

Plastic DIP 730mW

SOIC 500mW

TDFN 1W

Storage Temperature -65°C to 160°C

Lead Soldering Temperature (10 sec) 300°C

Note: T_A = Ambient Temperature

These are stress ratings only and functional operation is not implied. Exposure to absolute maximum ratings for prolonged time periods may affect device reliability. All voltages are with respect to ground.

Operating Ambient Temperature Range

CAT660E -40°C to 85°C

ELECTRICAL CHARACTERISTICS

V+ = 5V, C1 = C2 = 150μF, Boost/FC = Open, C_{OSC} = 0pF, inverter mode with test circuit as shown in Figure 1 unless otherwise noted. Temperature is over operating ambient temperature range unless otherwise noted.

Parameter	Symbol	Conditions	Min	Typ	Max	Units
Supply Voltage	VS	Inverter: LV = Open. R _L = 1kΩ	3.0		5.5	V
		Inverter: LV = GND. R _L = 1kΩ	1.5		5.5	
		Doubler: LV = OUT. R _L = 1kΩ	2.5		5.5	
Supply Current	IS	BOOST/FC = open, LV = Open		0.09	0.5	mA
		BOOST/FC = V+ , LV = Open		0.3	3	
Output Current	I _{OUT}	OUT is more negative than -4V	100			mA
Output Resistance	R _O	I _L = 100mA, C1 = C2 = 150 μF (Note 2) BOOST/FC = V+ (C1, C2 ESR ≤ 0.5Ω)		4	7	Ω
		I _L = 100mA, C1 = C2 = 10 μF			12	
Oscillator Frequency (Note 3)	F _{OSC}	BOOST/FC = Open	5	10		kHz
		BOOST/FC = V+	40	80		
OSC Input Current	I _{OSC}	BOOST/FC = Open BOOST/FC = V+		±1 ±5		μA
Power Efficiency	PE	R _L = 1kΩ connected between V+ and OUT, T _A = 25°C (Doubler)	96	98		%
		R _L = 500Ω connected between GND and OUT, T _A = 25°C (Inverter)	92	96		
		I _L = 100mA to GND, T _A = 25°C (Inverter)		88		
Voltage Conversion Efficiency	VEFF	No load, T _A = 25°C	99	99.9		%

Note 1. In Figure 1, test circuit capacitors C1 and C2 are 150μF and have 0.2Ω maximum ESR. Higher ESR levels may reduce efficiency and output voltage.

Note 2. The output resistance is a combination of the internal switch resistance and the external capacitor ESR. For maximum voltage and efficiency keep external capacitor ESR under 0.2Ω.

Note 3. F_{OSC} is tested with C_{OSC} = 100pF to minimize test fixture loading. The test is correlated back to C_{OSC}=0pF to simulate the capacitance at OSC when the device is inserted into a test socket without an external C_{OSC}.

Figure 1. Test Circuit

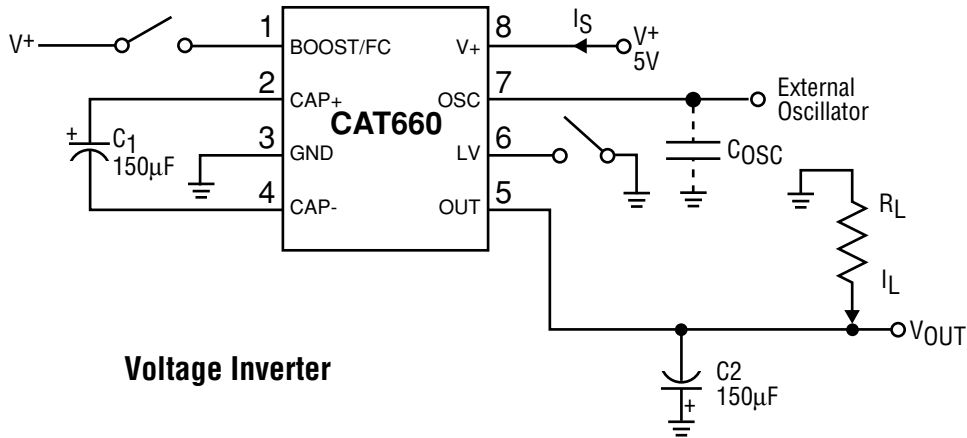

Voltage Inverter

TYPICAL OPERATING CHARACTERISTICS

Typical characteristic curves are generated using the test circuit in Figure 1. Inverter test conditions are: $V_+ = 5V$, $LV = GND$, $BOOST/FC = Open$ and $T_A = 25^\circ C$ unless otherwise indicated. Note that the charge-pump frequency is one-half the oscillator frequency.

Supply Current vs. Input Voltage

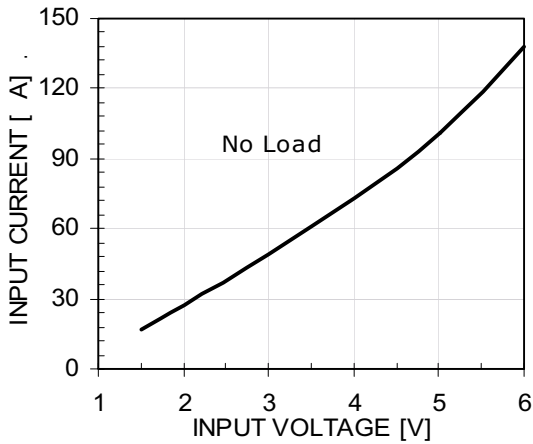

Supply Current vs. Temperature (no load)

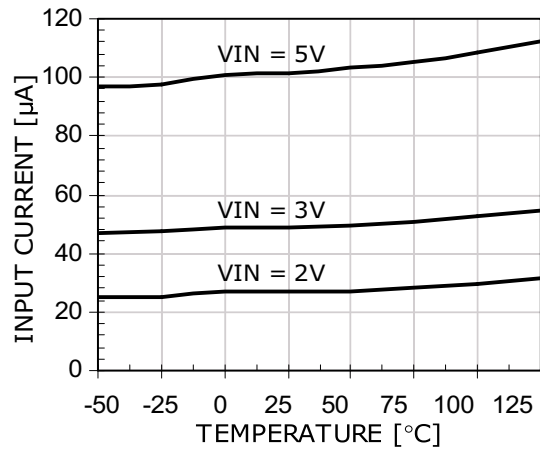

Output Resistance vs. Input Voltage

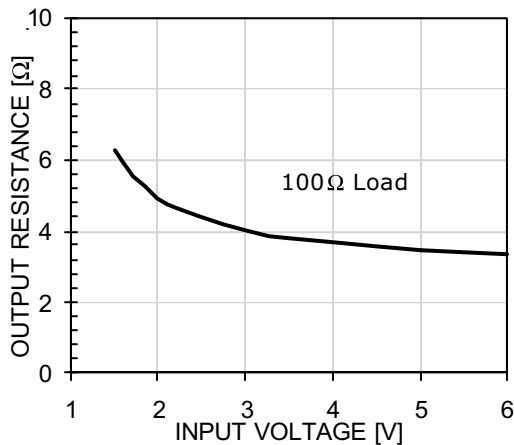

Output Resistance vs. Temperature (50Ω load)

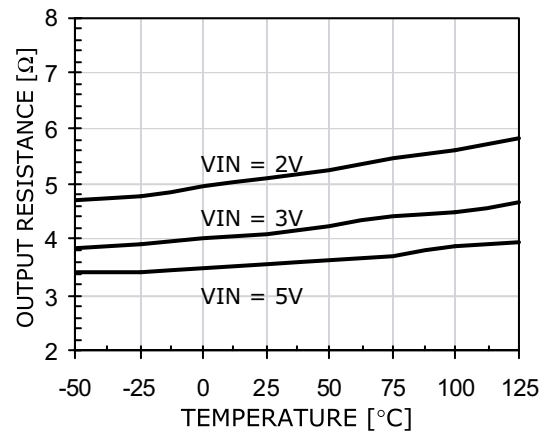

TYPICAL OPERATING CHARACTERISTICS

Inverted Output Voltage vs. Load, V+ = 5V

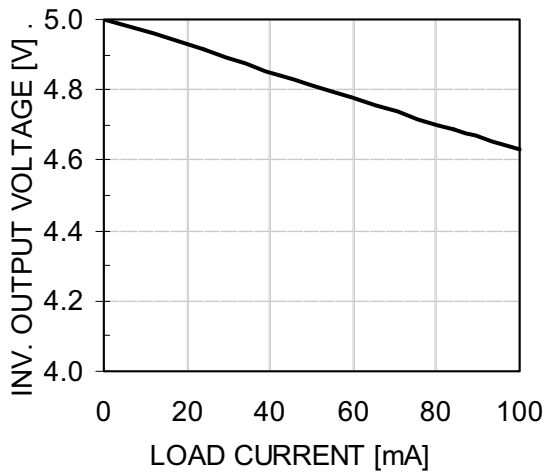

Output Voltage Drop vs. Load Current

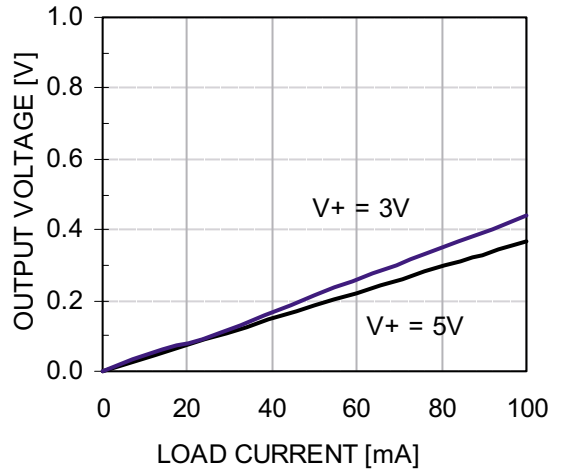

Oscillator Frequency vs. Supply Voltage

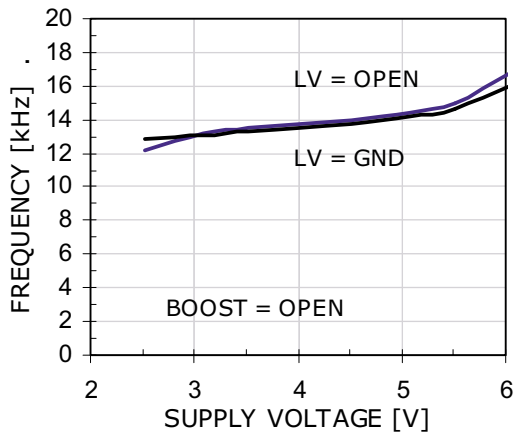

Oscillator Frequency vs. Supply Voltage

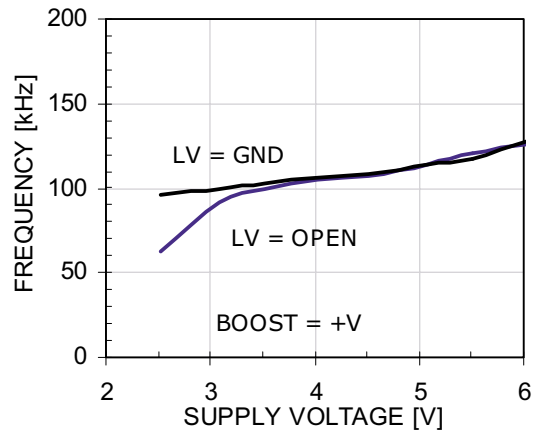

Supply Current vs. Oscillator Frequency

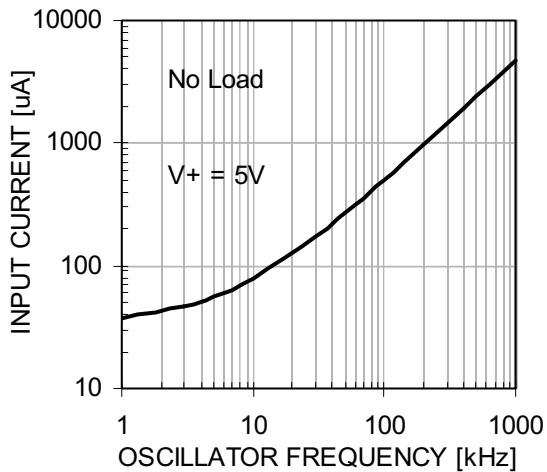

APPLICATION INFORMATION

Circuit Description and Operating Theory

The CAT660 switches capacitors to invert or double an input voltage.

Figure 2 shows a simple switch capacitor circuit. In position 1 capacitor C1 is charged to voltage V1. The total charge on C1 is Q1 = C1V1. When the switch moves to position 2, the input capacitor C1 is discharged to voltage V2. After discharge, the charge on C1 is Q2 = C1V2.

The charge transferred is:

$$\Delta Q = Q1 - Q2 = C1 \times (V1 - V2)$$

If the switch is cycled "F" times per second, the current (charge transfer per unit time) is:

$$I = F \times \Delta Q = F \times C1 (V1 - V2)$$

Rearranging in terms of impedance:

$$I = \frac{(V1-V2)}{(1/FC1)} = \frac{V1-V2}{REQ}$$

The 1/FC1 term can be modeled as an equivalent impedance REQ. A simple equivalent circuit is shown in figure 3. This circuit does not include the switch resistance nor does it include output voltage ripple. It does allow one to understand the switch-capacitor topology and make prudent engineering tradeoffs.

For example, power conversion efficiency is set by the output impedance, which consists of REQ and switch resistance. As switching frequency is decreased, REQ, the 1/FC1 term, will dominate the output impedance, causing higher voltage losses and decreased efficiency. As the frequency is increased quiescent current increases. At high frequency this current becomes significant and the power efficiency degrades.

The oscillator is designed to operate where voltage losses are a minimum. With external 150µF capacitors, the internal switch resistances and the Equivalent Series Resistance (ESR) of the external capacitors determine the effective output impedance.

A block diagram of the CAT660 is shown in figure 4. The CAT660 is a replacement for the MAX660 and the LTC660.

Figure 2. Switched-Capacitor Building Block

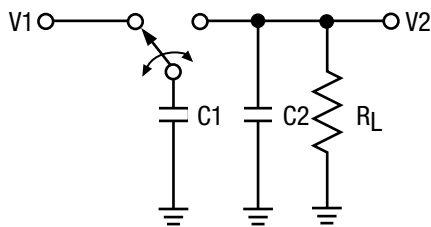
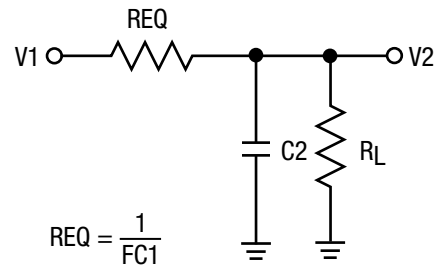

Figure 3. Switched-Capacitor Equivalent Circuit



OSCILLATOR FREQUENCY CONTROL

The switching frequency can be raised, lowered or driven from an external source. Figure 5 shows a functional diagram of the oscillator circuit.

The CAT660 oscillator has four control modes:

BOOST/FC Pin Connection	OSC Pin Connection	Nominal Oscillator Frequency
Open	Open	10kHz
BOOST/FC= V+	Open	80kHz
Open or BOOST/FC= V+	External Capacitor	—
Open	External Clock	Frequency of external clock

If BOOST/FC and OSC are left floating (Open), the nominal oscillator frequency is 10kHz. The pump frequency is one-half the oscillator frequency.

By connecting the BOOST/FC pin to V+, the charge and discharge currents are increased, and the frequency is increased by approximately 8 times. Increasing the frequency will decrease the output impedance and ripple currents. This can be an advantage at high load currents. Increasing the frequency raises quiescent current but allows smaller capacitance values for C1 and C2.

If pin 7, OSC, is loaded with an external capacitor the frequency is lowered. By using the BOOST/FC pin and

an external capacitor at OSC, the operating frequency can be set.

Note that the frequency appearing at CAP+ or CAP- is one-half that of the oscillator.

Driving the CAT660 from an external frequency source can be easily achieved by driving Pin 7 and leaving the BOOST pin open, as shown in Figure 6. The output current from Pin 7 is small, typically 1µA to 8µA, so a CMOS can drive the OSC pin. For 5V applications, a TTL logic gate can be used if an external 100kΩ pull-up resistor is used as shown in figure 6.

Figure 4. CAT660 Block Diagram

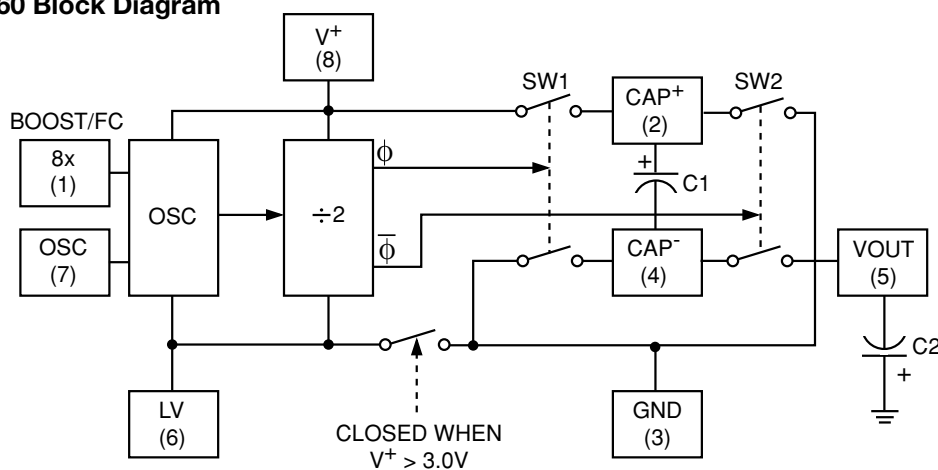

(N) = Pin Number

CAPACITOR SELECTION

Low ESR capacitors are necessary to minimize voltage losses, especially at high load currents. The exact values of C1 and C2 are not critical but low ESR capacitors are necessary.

The ESR of capacitor C1, the pump capacitor, can have a pronounced effect on the output. C1 currents are approximately twice the output current and losses occur on both the charge and discharge cycle. The ESR effects are thus multiplied by four. A 0.5Ω ESR for C1 will have the same effect as a 2Ω increase in CAT660 output impedance.

Output voltage ripple is determined by the value of C2 and the load current. C2 is charged and discharged at a current roughly equal to the load current. The internal switching frequency is one-half the oscillator frequency.

$$VRIPPLE = I_{OUT} / (F_{OSC} \times C2) + I_{OUT} \times ESR_{C2}$$

For example, with a 10kHz oscillator frequency (5kHz switching frequency), a 150μF C2 capacitor with an ESR of 0.2Ω and a 100mA load peak-to-peak ripple voltage is 87mV.

VRIPPLE vs. FOSC

VRIPPLE (mV)	IOUT (mA)	FOSC (kHz)	C2 (μF)	C2 ESR (Ω)
87	100	10	150	0.2
28	100	80	150	0.2

Figure 5. Oscillator

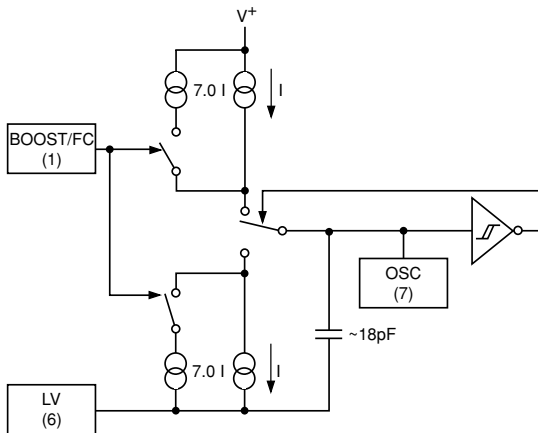
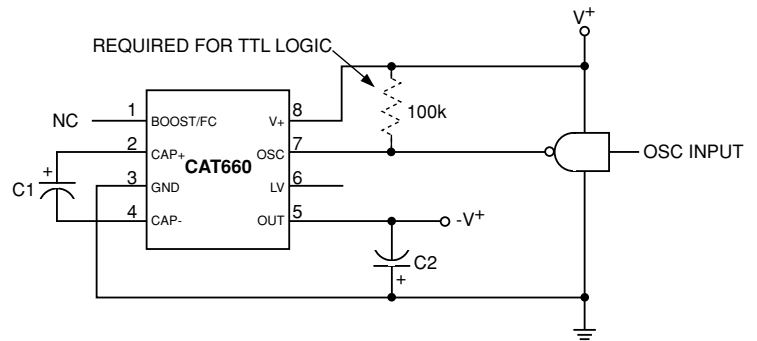

Figure 6. External Clocking



CAPACITOR SUPPLIERS

The following manufacturers supply low-ESR capacitors:

Manufacturer	Capacitor Type	Phone	WEB	Email	Comments
AVX/Kyocera	TPS/TPS3	843-448-9411	www.avxcorp.com	avx@avxcorp.com	Tantalum
Vishay/Sprague	595	402-563-6866	www.vishay.com	—	Aluminum
Sanyo	MV-AX, UGX	619-661-6835	www.sanyo.com	Svcsales@sanyo.com	Aluminum
Nichicon	F55	847-843-7500	www.nichicon-us.com	—	Tantalum
	HC/HD				Aluminum

Capacitor manufacturers continually introduce new series and offer different package styles. It is recommended that before a design is finalized capacitor manufacturers should be surveyed for their latest product offerings.

CONTROLLING LOSS IN CAT660 APPLICATIONS

There are three primary sources of voltage loss:

1. Output resistance
 $V_{LOSS\Omega} = I_{LOAD} \times R_{OUT}$, where R_{OUT} is the CAT660 output resistance and I_{LOAD} is the load current.
2. Charge pump (C1) capacitor ESR:
 $V_{LOSSC1} \approx 4 \times ESR_{C1} \times I_{LOAD}$, where $ESRC1$ is the ESR of capacitor C1.
3. Output or reservoir (C2) capacitor ESR:
 $V_{LOSSC2} = ESR_{C2} \times I_{LOAD}$, where $ESRC2$ is the ESR of capacitor C2.

Increasing the value of C2 and/or decreasing its ESR will reduce noise and ripple.

The effective output impedance of a CAT660 circuit is approximately:

$$R_{circuit} \approx R_{out\ 660} + (4 \times ESR_{C1}) + ESR_{C2}$$

TYPICAL APPLICATIONS

VOLTAGE INVERSION POSITIVE-TO-NEGATIVE

The CAT660 easily provides a negative supply voltage from a positive supply in the system. Figure 7 shows a typical circuit. The LV pin may be left floating for positive input voltages at or above 3.3V.

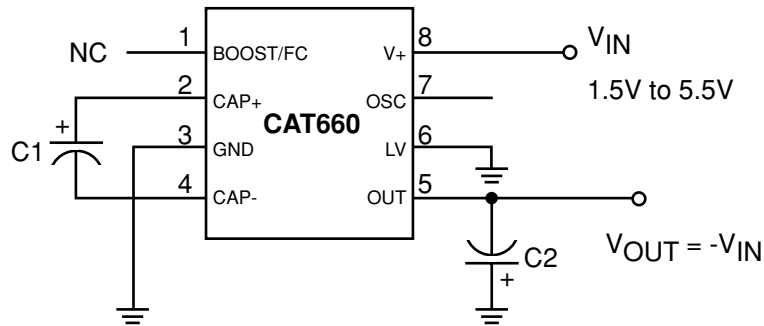
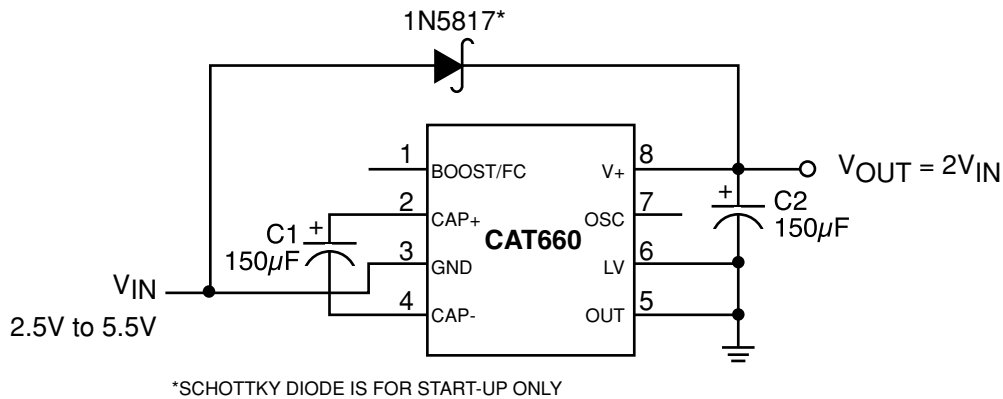

Figure 7: Voltage Inverter

POSITIVE VOLTAGE DOUBLER

The voltage doubler circuit shown in figure 8 gives $V_{OUT} = 2 \times V_{IN}$ for input voltages from 2.5V to 5.5V.



*SCHOTTKY DIODE IS FOR START-UP ONLY

Figure 8: Voltage Doubler

PRECISION VOLTAGE DIVIDER

A precision voltage divider is shown in figure 9. With very light load currents under 100nA, the voltage at pin 2 will be within 0.002% of $V_+/2$. Output voltage accuracy decreases with increasing load.

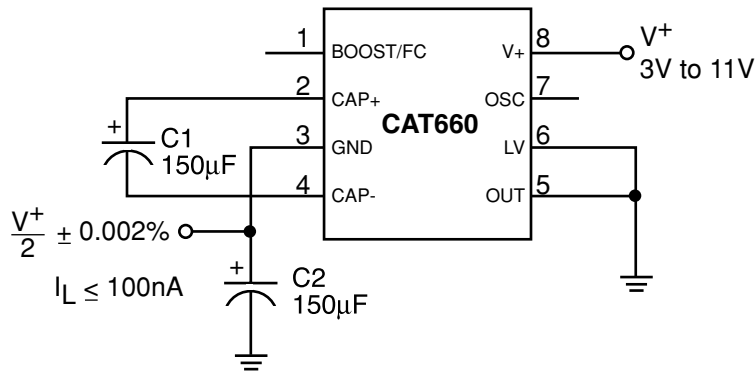

Figure 9: Precision Voltage Divider (Load ≤ 100nA)

BATTERY VOLTAGE SPLITTER

Positive and negative voltages that track each other can be obtained from a battery. Figure 10 shows how a 9V battery can provide symmetrical positive and negative voltages equal to one-half the battery voltage.

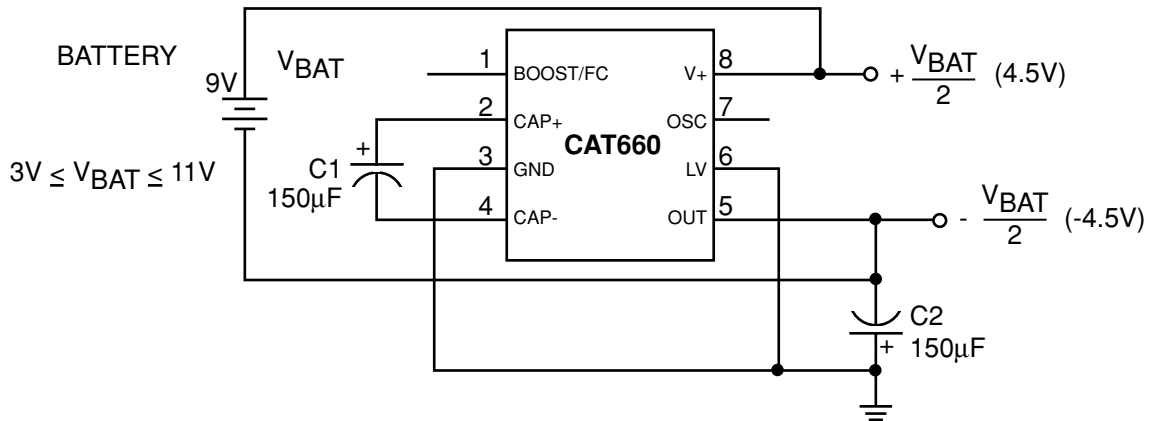

Figure 10: Battery Splitter

CASCADE OPERATION FOR HIGHER NEGATIVE VOLTAGES

The CAT660 can be cascaded as shown in figure 11 to generate more negative voltage levels. The output resistance is approximately the sum of the individual CAT660 output resistance.

$V_{OUT} = -N \times V_{IN}$, where N represents the number of cascaded devices.

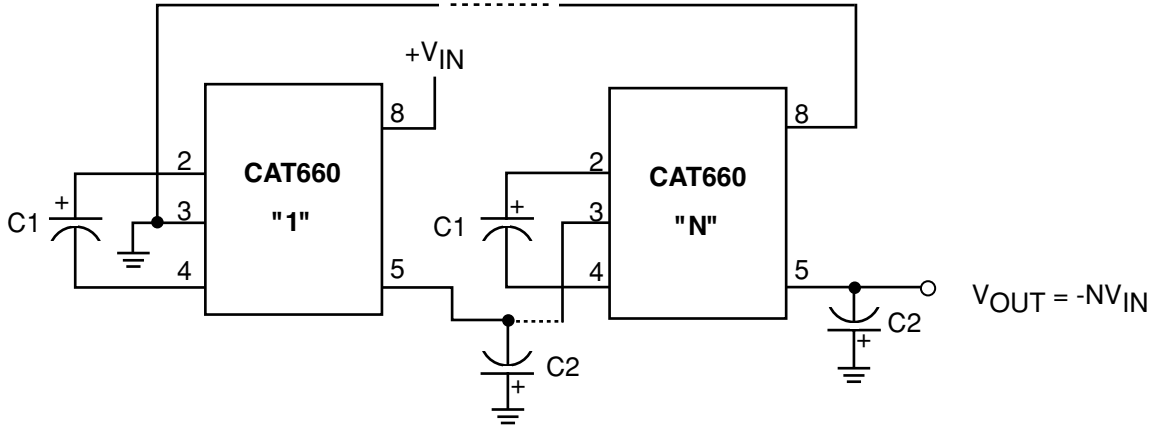

Figure 11: Cascading to Increase Output Voltage

PARALLEL OPERATION

Paralleling CAT660 devices will lower output resistance. As shown in figure 12, each device requires its own pump capacitor, C2, but the output reservoir capacitor is shared with all devices. The value of C2 should be increased by a factor of N, where N is the number of devices.

The output impedance of the combined CAT660's is:

$$R_{OUT}(\text{Of "N" CAT660's}) = \frac{R_{OUT}(\text{Of the CAT660})}{N(\text{Number of devices})}$$

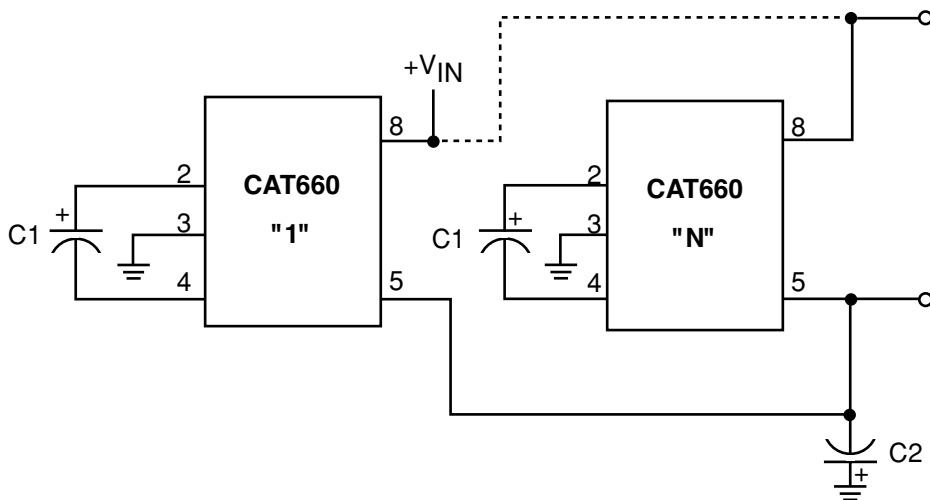
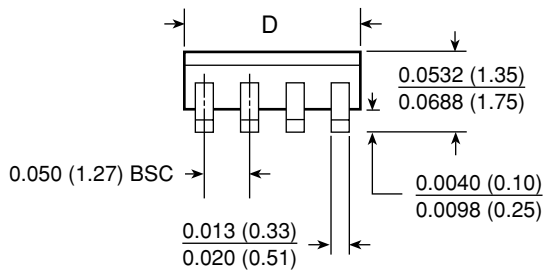
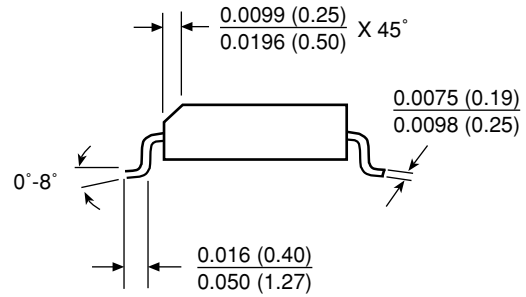
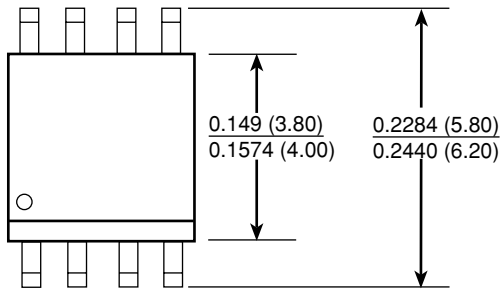

Figure 12: Paralleling Devices Reduce Output Resistance

PACKAGE MECHANICAL DRAWINGS

8-LEAD 150 WIDE SOIC (S, X)



Dimension D		
Pkg	Min	Max
8L	0.1890(4.80)	0.1968(5.00)

8-LEAD 300 MIL WIDE PLASTIC DIP (P)

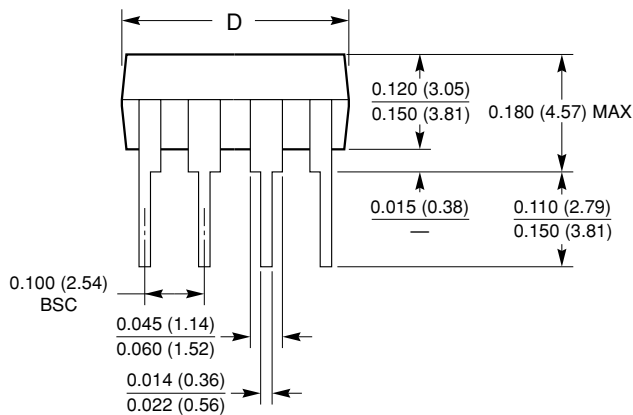
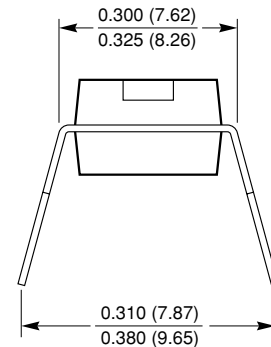
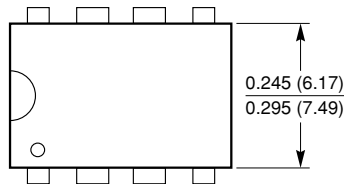

Dimension D		
Pkg	Min	Max
8L	0.355 (9.02)	0.400 (10.16)

Notes:

1. Complies with JEDEC Publication 95 MS001 dimensions; however, some of the dimensions may be more stringent.
2. All linear dimensions are in inches and parenthetically in millimeters.

8-PAD TDFN (RD8, ZD8)

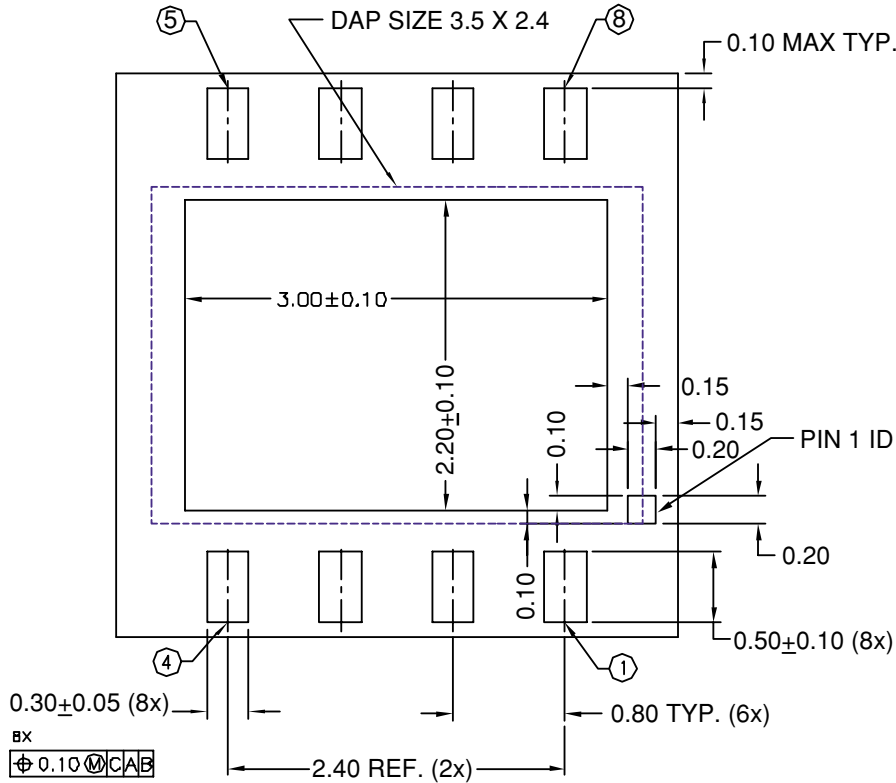
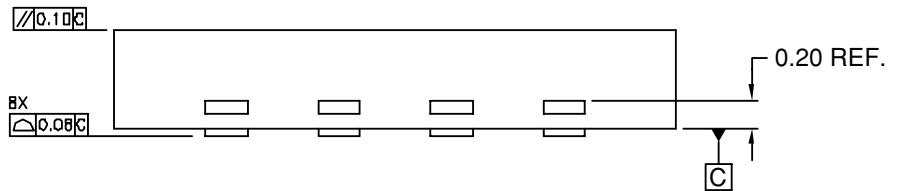
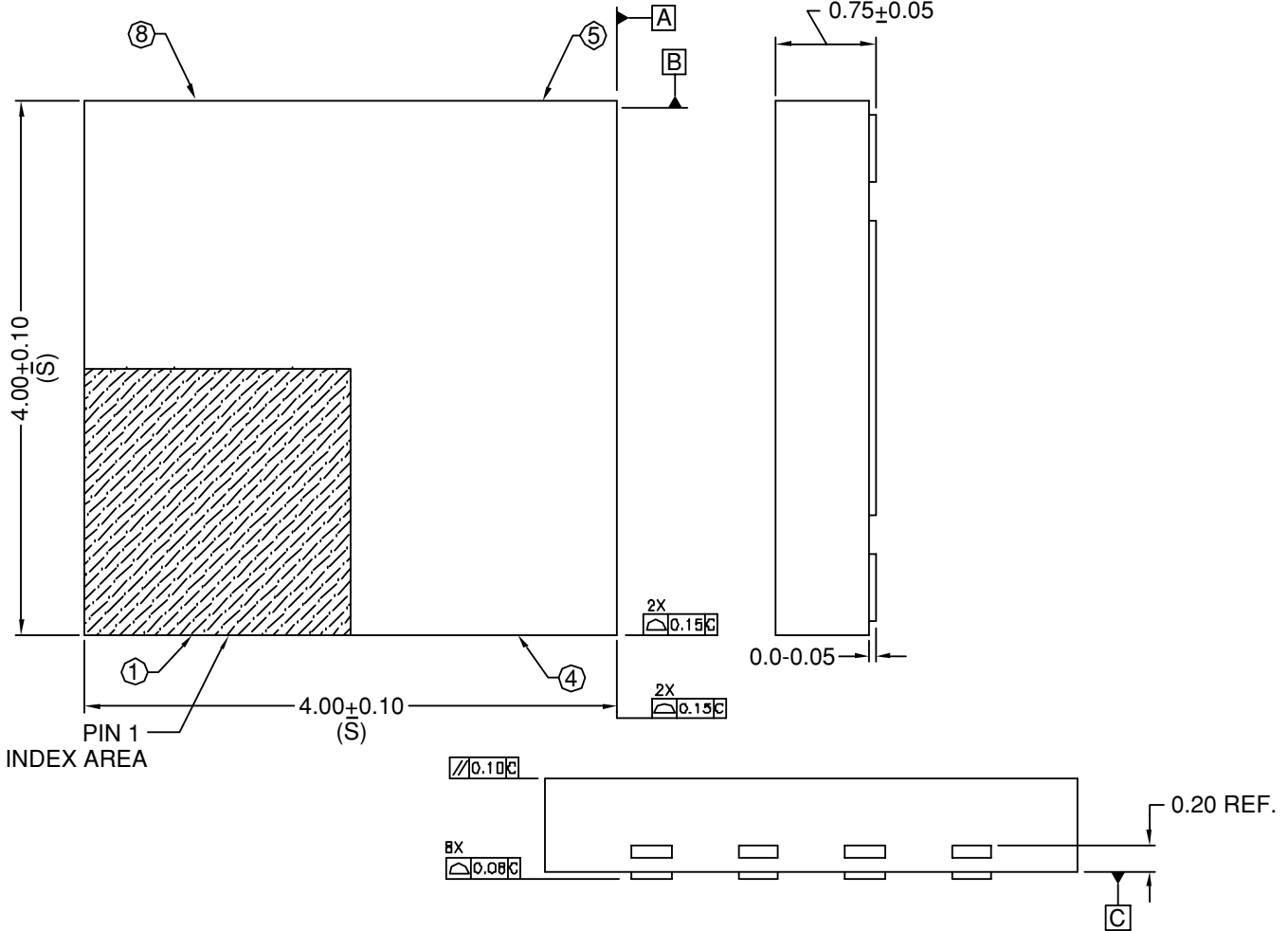

NOTE:

1. ALL DIMENSIONS ARE IN mm. ANGLES IN DEGREES.
2. COPLANARITY APPLIES TO THE EXPOSED PAD AS WELL AS THE TERMINALS. COPLANARITY SHALL NOT EXCEED 0.08mm.
3. WARPAGE SHALL NOT EXCEED 0.10mm.
4. PACKAGE LENGTH/PACKAGE WIDTH ARE CONSIDERED AS SPECIAL CHARACTERISTIC. (S)

REVISION HISTORY

Date	Rev.	Reason
10/6/2003	R	Updated Typical Operating Characteristics data plots
10/7/2003	S	Updated Electrical Characteristics - Output Resistance and Supply Current Updated Typical Operating Characteristics data plots
10/15/2003	T	Updated Description - eliminated Commercial temp range Updated ordering information - eliminated Commercial temp range Updated operating ambient temperature ranges
1/20/2005	U	Changed ordering information for CAT660EXA to CAT660EVA Changed ordering information for CAT660EXA-TE13 to CAT660EVA-TE13

Copyrights, Trademarks and Patents

Trademarks and registered trademarks of Catalyst Semiconductor include each of the following:

DPP™ AE²™

Catalyst Semiconductor has been issued U.S. and foreign patents and has patent applications pending that protect its products. For a complete list of patents issued to Catalyst Semiconductor contact the Company's corporate office at 408.542.1000.

CATALYST SEMICONDUCTOR MAKES NO WARRANTY, REPRESENTATION OR GUARANTEE, EXPRESS OR IMPLIED, REGARDING THE SUITABILITY OF ITS PRODUCTS FOR ANY PARTICULAR PURPOSE, NOR THAT THE USE OF ITS PRODUCTS WILL NOT INFRINGE ITS INTELLECTUAL PROPERTY RIGHTS OR THE RIGHTS OF THIRD PARTIES WITH RESPECT TO ANY PARTICULAR USE OR APPLICATION AND SPECIFICALLY DISCLAIMS ANY AND ALL LIABILITY ARISING OUT OF ANY SUCH USE OR APPLICATION, INCLUDING BUT NOT LIMITED TO, CONSEQUENTIAL OR INCIDENTAL DAMAGES.

Catalyst Semiconductor products are not designed, intended, or authorized for use as components in systems intended for surgical implant into the body, or other applications intended to support or sustain life, or for any other application in which the failure of the Catalyst Semiconductor product could create a situation where personal injury or death may occur.

Catalyst Semiconductor reserves the right to make changes to or discontinue any product or service described herein without notice. Products with data sheets labeled "Advance Information" or "Preliminary" and other products described herein may not be in production or offered for sale.

Catalyst Semiconductor advises customers to obtain the current version of the relevant product information before placing orders. Circuit diagrams illustrate typical semiconductor applications and may not be complete.



CATALYST

Catalyst Semiconductor, Inc.
Corporate Headquarters
1250 Borregas Avenue
Sunnyvale, CA 94089
Phone: 408.542.1000
Fax: 408.542.1200
www.catalyst-semiconductor.com

Publication #: 5000
Revision: U
Issue date: 1/20/2005
Type: Preliminary