



CAT93C46R

1-Kb Microwire Serial EEPROM

FEATURES

- High speed operation: 4MHz @ 5V, 2MHz @ 1.8V
- 1.8V to 5.5V supply voltage range
- Selectable x8 or x16 memory organization
- Sequential read
- Software write protection
- Power-up inadvertent write protection
- Low power CMOS technology
- 1,000,000 program/erase cycles
- 100 year data retention
- Industrial temperature range
- RoHS-compliant 8-pin PDIP, SOIC, TSSOP and 8-pad TDFN packages

PIN CONFIGURATION

PDIP (L)			SOIC (W)				
SOIC (V, X)							
TSSOP (Y)							
TDFN (VP2)							
CS	1	8	V _{CC}	NC	1	8	ORG
SK	2	7	NC	V _{CC}	2	7	GND
DI	3	6	ORG	CS	3	6	DO
DO	4	5	GND	SK	4	5	DI

PIN FUNCTIONS

Pin Name	Function
CS	Chip Select
SK	Clock Input
DI	Serial Data Input
DO	Serial Data Output
V _{CC}	Power Supply
GND	Ground
ORG	Memory Organization
NC	No Connection

Note: When the ORG pin is connected to V_{CC}, the x16 organization is selected. When it is connected to ground, the x8 pin is selected. If the ORG pin is left unconnected, then an internal pull-up device will select the x16 organization.

DESCRIPTION

The CAT93C46R is a 1-Kb CMOS Serial EEPROM device which is organized as either 64 registers of 16 bits or 128 registers of 8 bits, as determined by the state of the ORG pin. The CAT93C46R features sequential read and self-timed internal write with auto-clear. On-chip Power-On Reset circuitry protects the internal logic against powering up in the wrong state.

In contrast to the CAT93C46, the CAT93C46R features an internal instruction clock counter which provides improved noise immunity for Write/Erase commands.

FUNCTIONAL SYMBOL

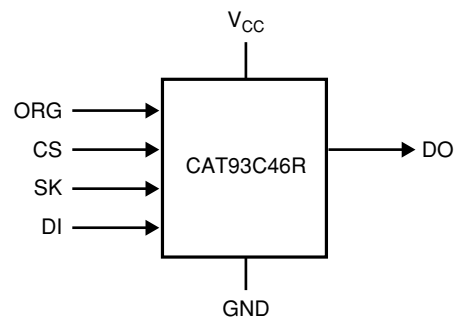

For Ordering Information details, see page 12.



* The Green & Gold seal identifies RoHS-compliant packaging, using NiPdAu pre-plated lead frames.

ABSOLUTE MAXIMUM RATINGS ⁽¹⁾

Storage Temperature	-65°C to +150°C
Voltage on Any Pin with Respect to Ground ⁽²⁾	-0.5 V to +6.5 V

RELIABILITY CHARACTERISTICS ⁽³⁾

Symbol	Parameter	Min	Units
N _{END} ⁽⁴⁾	Endurance	1,000,000	Program/ Erase Cycles
T _{DR}	Data Retention	100	Years

D.C. OPERATING CHARACTERISTICS

V_{CC} = +1.8V to +5.5V, unless otherwise specified.

Symbol	Parameter	Test Conditions	Min	Max	Units
I _{CC1}	Power Supply Current (Write)	f _{SK} = 1MHz V _{CC} = 5.0V		1	mA
I _{CC2}	Power Supply Current (Read)	f _{SK} = 1MHz V _{CC} = 5.0V		500	μA
I _{SB1}	Power Supply Current (Standby) (x8 Mode)	CS = 0V ORG = GND		10	μA
I _{SB2}	Power Supply Current (Standby) (x16 Mode)	CS = 0V ORG = Float or V _{CC}		10	μA
I _{LI}	Input Leakage Current	V _{IN} = 0V to V _{CC}		2	μA
I _{LO}	Output Leakage Current (Including ORG pin)	V _{OUT} = 0V to V _{CC} , CS = 0V		2	μA
V _{IL1}	Input Low Voltage	4.5V ≤ V _{CC} < 5.5V	-0.1	0.8	V
V _{IH1}	Input High Voltage	4.5V ≤ V _{CC} < 5.5V	2	V _{CC} + 1	V
V _{IL2}	Input Low Voltage	1.8V ≤ V _{CC} < 4.5V	0	V _{CC} × 0.2	V
V _{IH2}	Input High Voltage	1.8V ≤ V _{CC} < 4.5V	V _{CC} × 0.7	V _{CC} +1	V
V _{OL1}	Output Low Voltage	4.5V ≤ V _{CC} < 5.5V I _{OL} = 2.1mA		0.4	V
V _{OH1}	Output High Voltage	4.5V ≤ V _{CC} < 5.5V I _{OH} = -400μA	2.4		V
V _{OL2}	Output Low Voltage	1.8V ≤ V _{CC} < 4.5V I _{OL} = 1mA		0.2	V
V _{OH2}	Output High Voltage	1.8V ≤ V _{CC} < 4.5V I _{OH} = -100μA	V _{CC} - 0.2		V

Note:

- (1) Stresses above those listed under “Absolute Maximum Ratings” may cause permanent damage to the device. These are stress ratings only, and functional operation of the device at these or any other conditions outside of those listed in the operational sections of this specification is not implied. Exposure to any absolute maximum rating for extended periods may affect device performance and reliability.
- (2) The DC input voltage on any pin should not be lower than -0.5V or higher than V_{CC} +0.5V. During transitions, the voltage on any pin may undershoot to no less than -1.5V or overshoot to no more than V_{CC} +1.5V, for periods of less than 20 ns.
- (3) These parameters are tested initially and after a design or process change that affects the parameter according to appropriate AEC-Q100 and JEDEC test methods.
- (4) Block Mode, V_{CC} = 5V, T_A = 25°C.

PIN CAPACITANCE

Symbol	Test	Conditions	Max	Units
C _{OUT} ⁽¹⁾	Output Capacitance (DO)	V _{OUT} = 0V	5	pF
C _{IN} ⁽¹⁾	Input Capacitance (CS, SK, DI, ORG)	V _{IN} = 0V	5	pF

A.C. CHARACTERISTICS⁽²⁾

Symbol	Parameter	V _{CC} = 1.8V- 5.5V		V _{CC} = 4.5V- 5.5V		Units
		Min	Max	Min	Max	
t _{CS}	CS Setup Time	50		50		ns
t _{CSH}	CS Hold Time	0		0		ns
t _{DIS}	DI Setup Time	100		50		ns
t _{DIH}	DI Hold Time	100		50		ns
t _{PD1}	Output Delay to 1		0.25		0.1	μs
t _{PD0}	Output Delay to 0		0.25		0.1	μs
t _{HZ} ⁽¹⁾	Output Delay to High-Z		100		100	ns
t _{EW}	Program/Erase Pulse Width		5		5	ms
t _{CSMIN}	Minimum CS Low Time	0.25		0.1		μs
t _{SKHI}	Minimum SK High Time	0.25		0.1		μs
t _{SKLOW}	Minimum SK Low Time	0.25		0.1		μs
t _{SV}	Output Delay to Status Valid		0.25		0.1	μs
SK _{MAX}	Maximum Clock Frequency	DC	2	DC	4	MHz

POWER-UP TIMING⁽¹⁾⁽³⁾

Symbol	Parameter	Max	Units
t _{PUR}	Power-up to Read Operation	1	ms
t _{PUW}	Power-up to Write Operation	1	ms

A.C. TEST CONDITIONS

Input Rise and Fall Times	≤ 50ns	
Input Pulse Voltages	0.4V to 2.4V	4.5V ≤ V _{CC} ≤ 5.5V
Timing Reference Voltages	0.8V, 2.0V	4.5V ≤ V _{CC} ≤ 5.5V
Input Pulse Voltages	0.2V _{CC} to 0.7V _{CC}	1.8V ≤ V _{CC} ≤ 4.5V
Timing Reference Voltages	0.5V _{CC}	1.8V ≤ V _{CC} ≤ 4.5V
Output Load	Current Source I _{OLmax} /I _{OHmax} ; C _L = 100pF	

NOTE:

- (1) These parameters are tested initially and after a design or process change that affects the parameter according to appropriate AEC-Q100 and JEDEC test methods.
- (2) Test conditions according to "A.C. Test Conditions" table.
- (3) t_{PUR} and t_{PUW} are the delays required from the time V_{CC} is stable until the specified operation can be initiated.

INSTRUCTION SET

Instruction	Start Bit	Opcode	Address		Data		Comments
			x8	x16	x8	x16	
READ	1	10	A6-A0	A5-A0			Read Address AN– A0
ERASE	1	11	A6-A0	A5-A0			Clear Address AN– A0
WRITE	1	01	A6-A0	A5-A0	D7-D0	D15-D0	Write Address AN– A0
EWEN	1	00	11XXXXX	11XXXX			Write Enable
EWDS	1	00	00XXXXX	00XXXX			Write Disable
ERAL	1	00	10XXXXX	10XXXX			Clear All Addresses
WRAL	1	00	01XXXXX	01XXXX	D7-D0	D15-D0	Write All Addresses

DEVICE OPERATION

The CAT93C46R is a 1024-bit nonvolatile memory intended for use with industry standard microprocessors. The CAT93C46R can be organized as either registers of 16 bits or 8 bits. When organized as X16, seven 9-bit instructions control the reading, writing and erase operations of the device. When organized as X8, seven 10-bit instructions control the reading, writing and erase operations of the device. The CAT93C46R operates on a single power supply and will generate on chip the high voltage required during any write operation.

Instructions, addresses, and write data are clocked into the DI pin on the rising edge of the clock (SK). The DO pin is normally in a high impedance state except when reading data from the device, or when checking the ready/busy status after a write operation.

The ready/busy status can be determined after the start of a write operation by selecting the device (CS high) and polling the DO pin; DO low indicates that the write operation is not completed, while DO high indicates that the device is ready for the next instruction. If necessary, the DO pin may be placed back into a high impedance state during chip select by shifting a dummy "1" into the DI pin. The DO pin will enter the high impedance state on the rising edge of the clock (SK). Placing the DO pin into the high impedance state is recommended in applications where the DI pin and the DO pin are to be tied together to form a common DI/O pin. The Ready/Busy flag can be disabled only in Ready state; no change is allowed in Busy state.

The format for all instructions sent to the device is a logical "1" start bit, a 2-bit (or 4-bit) opcode, 6-bit address (an additional bit when organized X8) and for write operations a 16-bit data field (8-bit for X8 organization).

Read

Upon receiving a READ command and an address (clocked into the DI pin), the DO pin of the CAT93C46R will come out of the high impedance state and, after sending an initial dummy zero bit, will begin shifting out the data addressed (MSB first). The output data bits will toggle on the rising edge of the SK clock and are stable after the specified time delay (t_{PD0} or t_{PD1}).

Sequential Read

After the 1st data word has been shifted out and CS remains asserted with the SK clock continuing to toggle, the CAT93C46R will automatically increment to the next address and shift out the next data word. As long as CS is continuously asserted and SK continues to toggle, the device will keep incrementing to the next address automatically until it reaches the end of the address space, then loops back to address 0. In the sequential Read mode, only the initial data word is preceded by a dummy zero bit; all subsequent data words will follow without a dummy zero bit.

Erase/Write Enable and Disable

The CAT93C46R powers up in the write disable state. Any writing after power-up or after an EWDS (write disable) instruction must first be preceded by the EWEN (write enable) instruction. Once the write instruction is enabled, it will remain enabled until power to the device is removed, or the EWDS instruction is sent. The EWDS instruction can be used to disable all CAT93C46R write and erase instructions, and will prevent any accidental writing or clearing of the device. Data can be read normally from the device regardless of the write enable/disable status.

Figure 1. Synchronous Data Timing

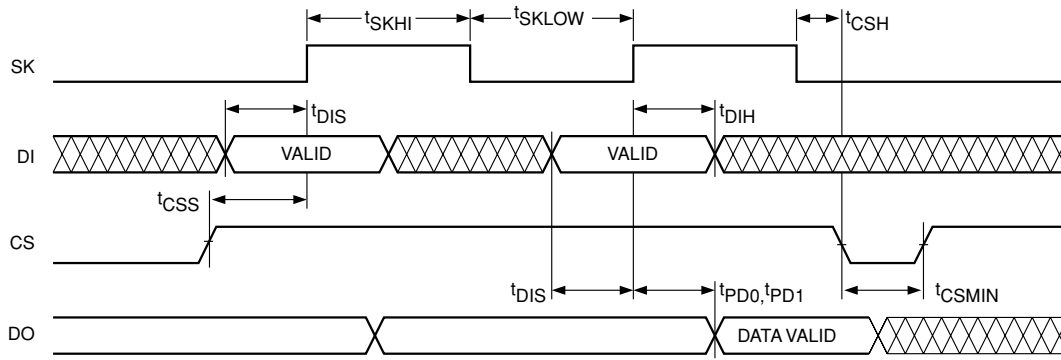

Figure 2. Read Instruction Timing

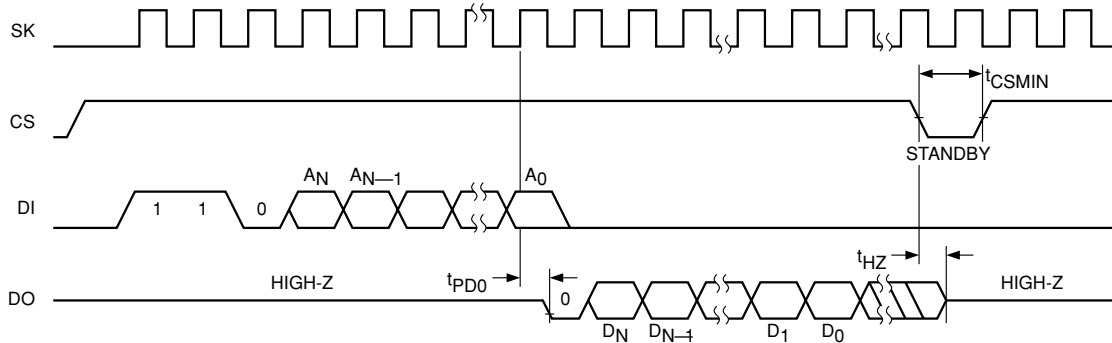

Figure 2b. Sequential Read Instruction Timing

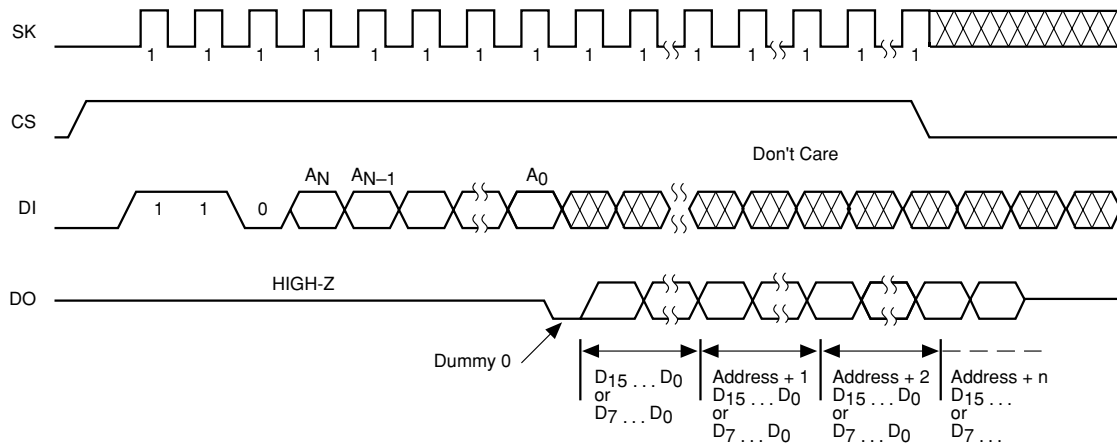
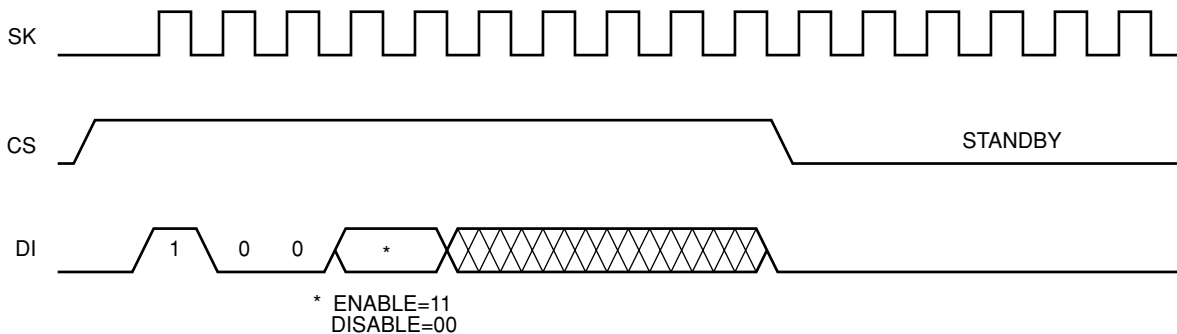

Figure 3. EWEN/EWDS Instruction Timing



Write

After receiving a WRITE command, address and the data, the CS (Chip Select) pin must be deselected for a minimum of t_{CSMIN} (see **Design Note** for details). The falling edge of CS will start the self clocking clear and data store cycle of the memory location specified in the instruction. The clocking of the SK pin is not necessary after the device has entered the self clocking mode. The ready/busy status of the CAT93C46R can be determined by selecting the device and polling the DO pin. Since this device features Auto-Clear before write, it is NOT necessary to erase a memory location before it is written into.

Erase

Upon receiving an ERASE command and address, the CS (Chip Select) pin must be deasserted for a minimum of t_{CSMIN} after the proper number of clock pulses (see **Design Note**). The falling edge of CS will start the self clocking clear cycle of the selected memory location. The clocking of the SK pin is not necessary after the device has entered the self clocking mode. The ready/busy status of the CAT93C46R can be determined by selecting the device and polling the DO pin. Once cleared, the content of a cleared location returns to a logical “1” state.

Erase All

Upon receiving an ERAL command, the CS (Chip Select) pin must be deselected for a minimum of t_{CSMIN} . The falling edge of CS will start the self clocking clear cycle of all memory locations in the device. The clocking of the SK pin is not necessary after the device has entered the self clocking mode. The ready/busy status of the CAT93C46R can be determined by selecting the device and polling the DO pin. Once cleared, the contents of all memory bits return to a logical “1” state.

Write All

Upon receiving a WRAL command and data, the CS (Chip Select) pin must be deselected for a minimum of t_{CSMIN} . The falling edge of CS will start the self clocking data write to all memory locations in the device. The clocking of the SK pin is not necessary after the device has entered the self clocking mode. (*Note 1.*) The ready/busy status of the CAT93C46R can be determined by selecting the device and polling the DO pin. It is not necessary for all memory locations to be cleared before the WRAL command is executed.

Design Note

With CAT93C46R, after the last data bit has been sampled, Chip Select (CS) must be brought Low before the next rising edge of the clock(SK) in order to start the self-timed high voltage cycle. This is important because if the CS is brought low before or after this specific frame window, the addressed location will not be programmed or erased.

Figure 4. Write Instruction Timing

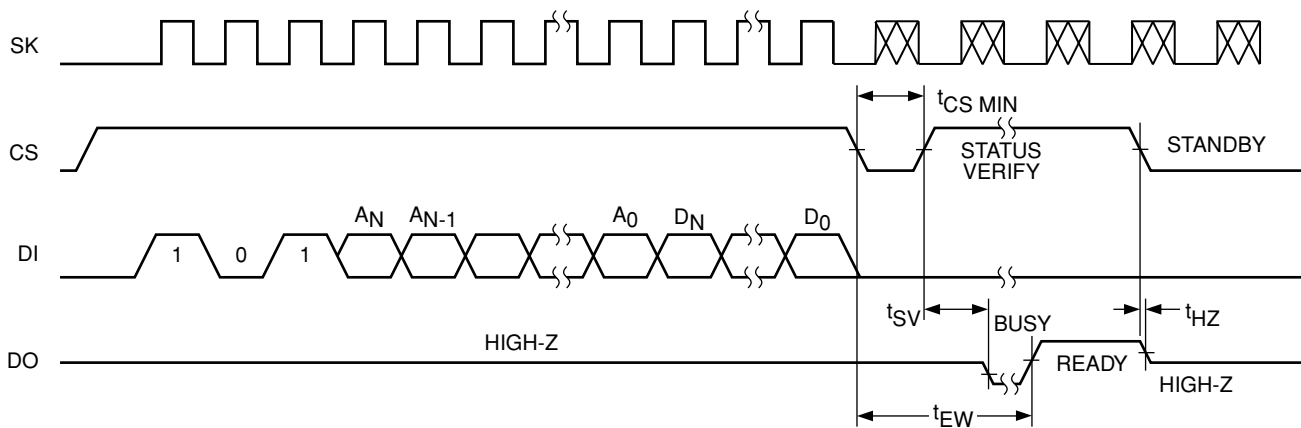

Figure 5. Erase Instruction Timing

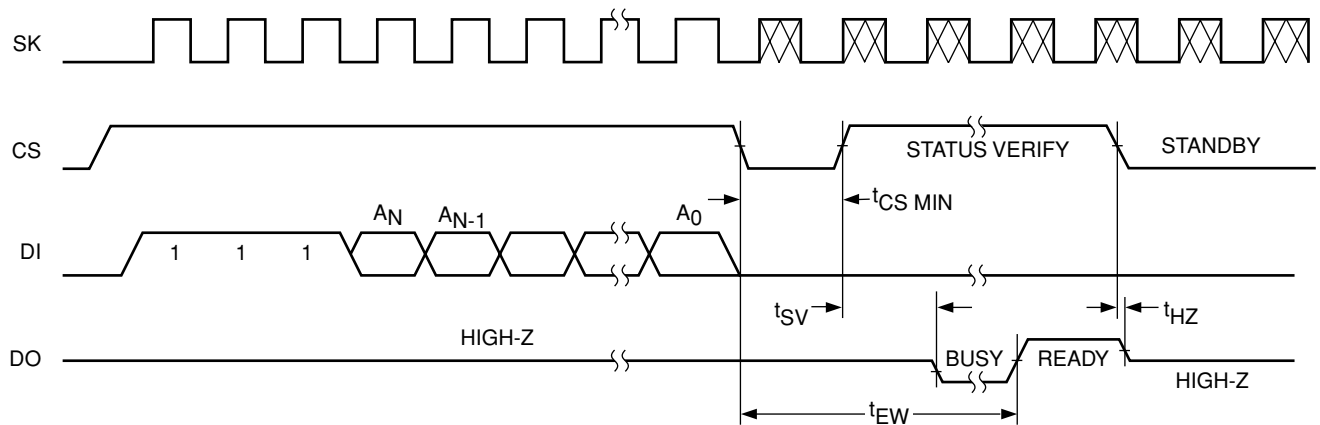

Figure 6. ERAL Instruction Timing

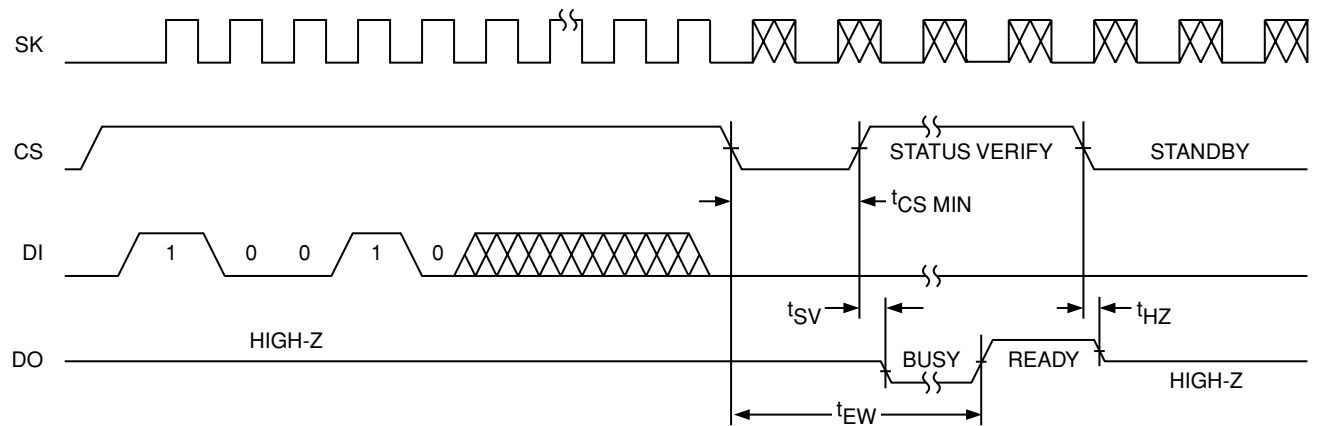
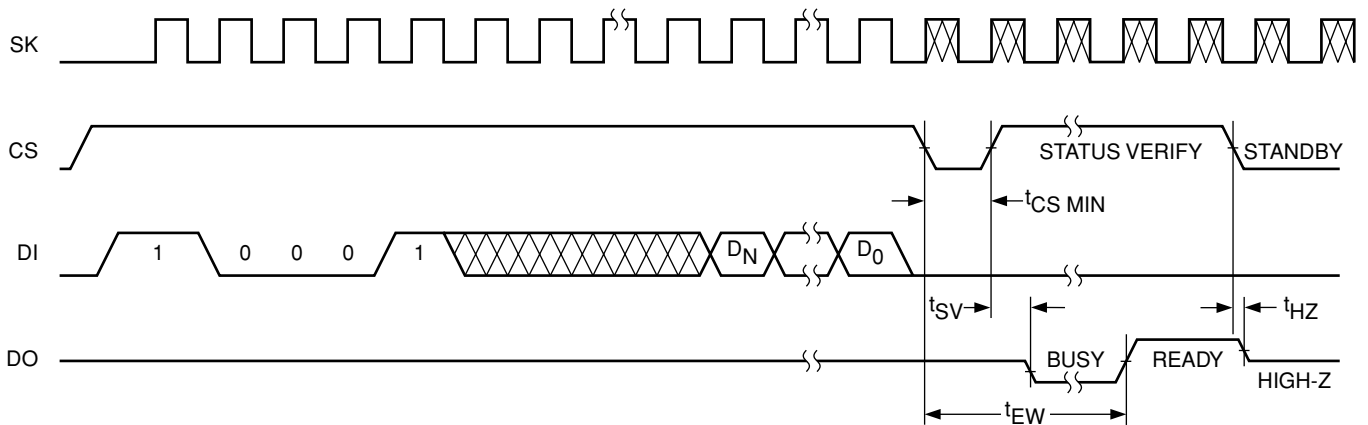
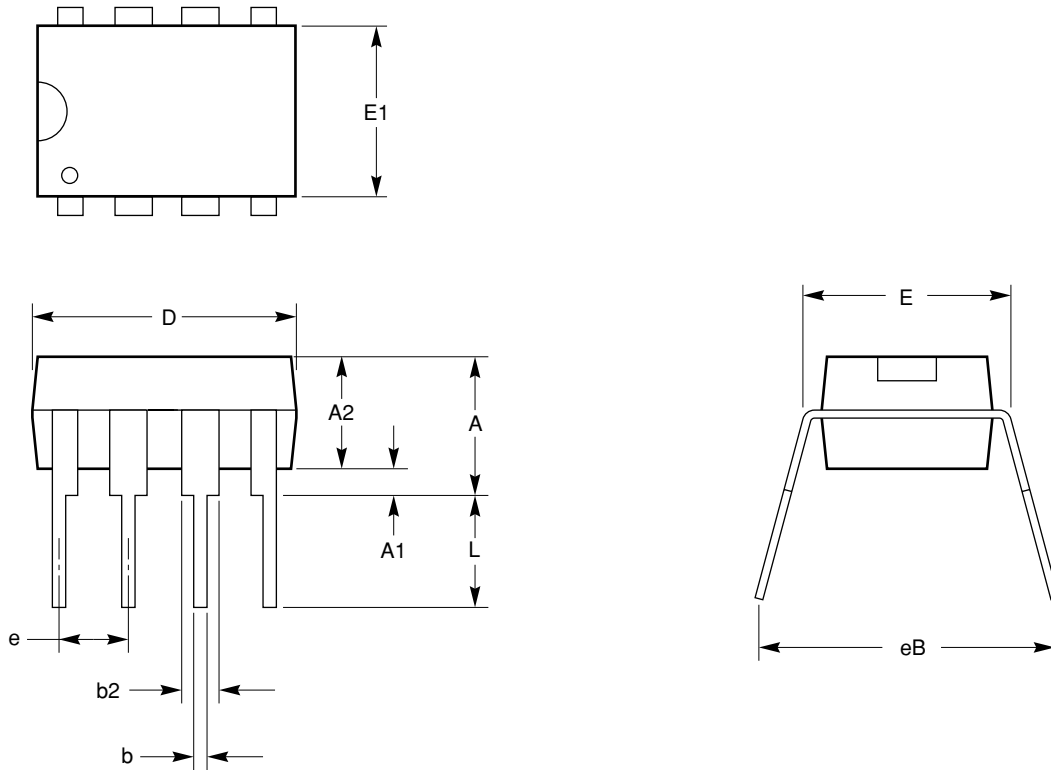

Figure 7. WRAL Instruction Timing



8-LEAD 300 MIL WIDE PLASTIC DIP (L)



SYMBOL	MIN	NOM	MAX
A			4.57
A1	0.38		
A2	3.05		3.81
b	0.36	0.46	0.56
b2	1.14		1.77
D	9.02		10.16
E	7.62	7.87	8.25
E1	6.09	6.35	7.11
e	2.54 BSC		
eB	7.87		9.65
L	0.115	0.130	0.150

Notes:

1. All dimensions are in millimeters.
2. Complies with JEDEC Standard MS001.
3. Dimensioning and tolerancing per ANSI Y14.5M-1982

8-LEAD 150 MIL WIDE SOIC (V, W)

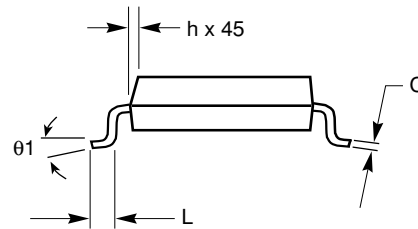
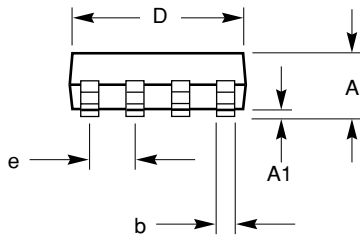
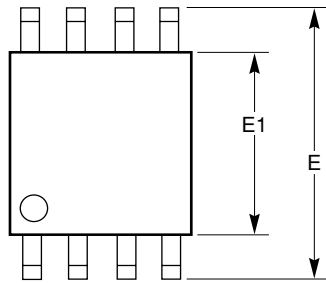

SYMBOL	MIN	NOM	MAX
A1	0.10		0.25
A	1.35		1.75
b	0.33		0.51
C	0.19		0.25
D	4.80		5.00
E	5.80		6.20
E1	3.80		4.00
e	1.27 BSC		
h	0.25		0.50
L	0.40		1.27
θ1	0°		8°

**For current Tape and Reel information, download the PDF file from:
<http://www.catsemi.com/documents/tapeandreel.pdf>.**

Notes:

1. All dimensions are in millimeters.
2. Complies with JEDEC specification MS-012.

8-LEAD TSSOP (Y)

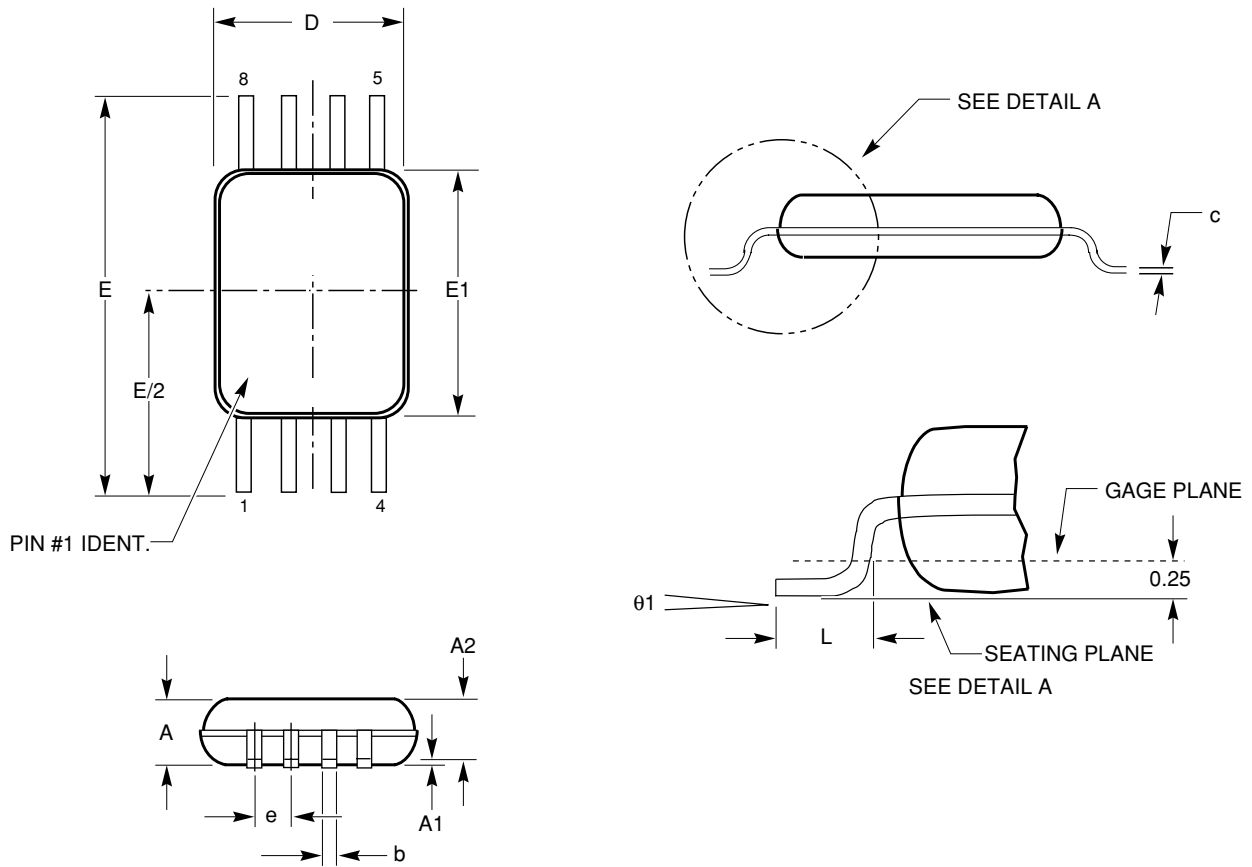

SYMBOL	MIN	NOM	MAX
A			1.20
A1	0.05		0.15
A2	0.80	0.90	1.05
b	0.19		0.30
c	0.09		0.20
D	2.90	3.00	3.10
E	6.30	6.4	6.50
E1	4.30	4.40	4.50
e	0.65 BSC		
L	0.50	0.60	0.75
$\theta 1$	0.00		8.00

For current Tape and Reel information, download the PDF file from:
<http://www.catsemi.com/documents/tapeandreeel.pdf>

Notes:

1. All dimensions are in millimeters.
2. Complies with JEDEC Standard MO-153

8-PAD TDFN 2X3 PACKAGE (VP2)

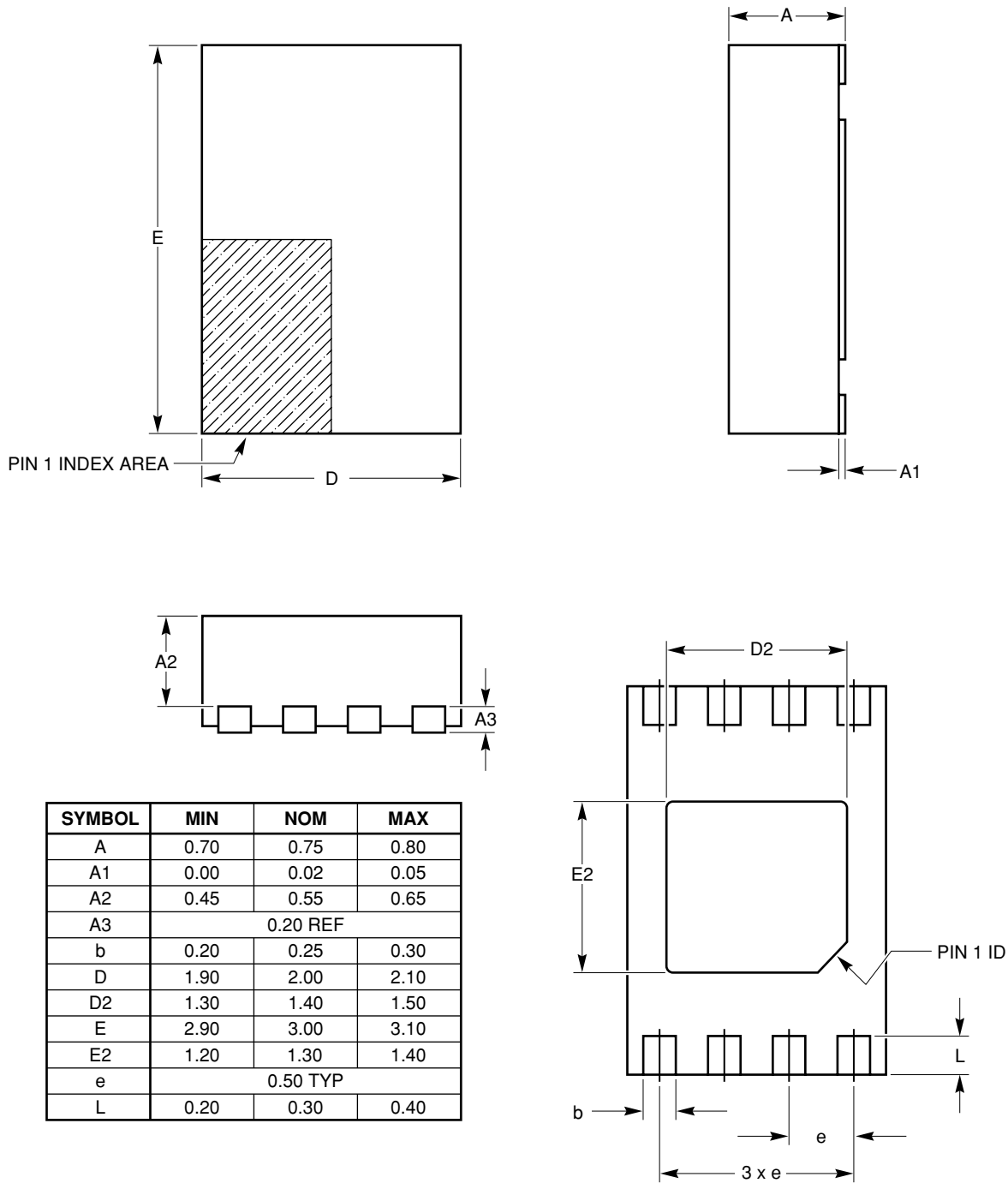

**For current Tape and Reel information, download the PDF file from:
<http://www.catsemi.com/documents/tapeandreel.pdf>**

- Notes:
1. All dimensions are in millimeters.
 2. Complies with JEDEC specification MS-229.

ORDERING INFORMATION

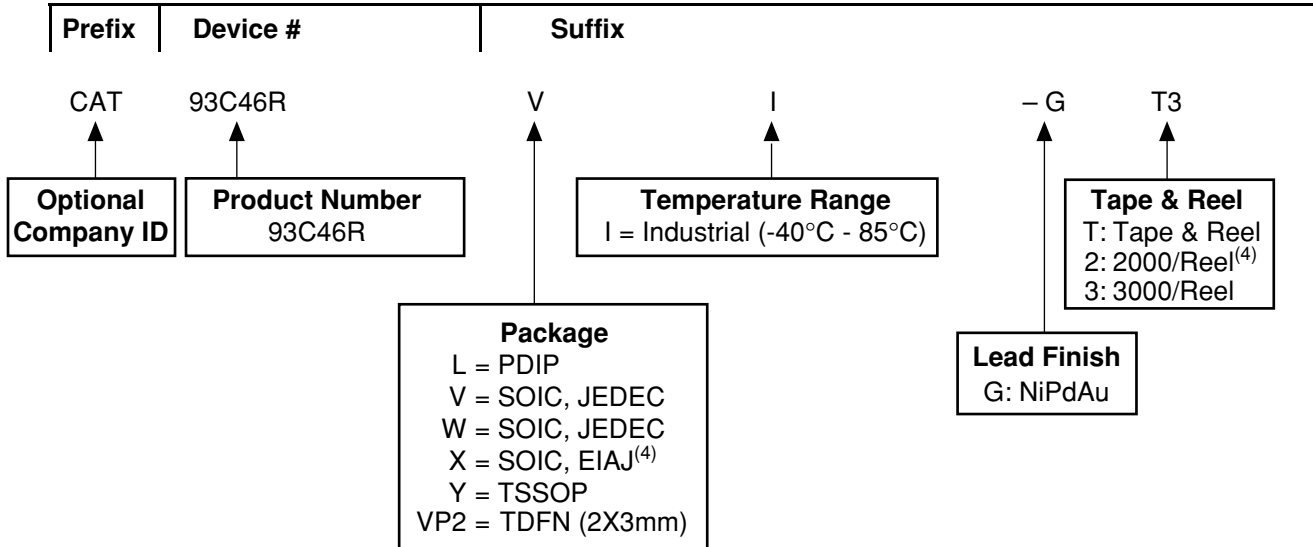

Notes:

- (1) All packages are RoHS-compliant (Lead-free, Halogen-free).
- (2) The standard lead finish is NiPdAu.
- (3) The device used in the above example is a CAT93C46RVI-GT3 (SOIC, Industrial Temperature, NiPdAu, Tape & Reel).
- (4) For SOIC, EIAJ (X) package the standard lead finish is Matte-Tin. This package is available in 2000 pcs/reel, i.e. CAT93C46RXI-T2.
- (5) For additional package and temperature options, please contact your nearest Catalyst Semiconductor Sales office.

REVISION HISTORY

Date	Revision	Comments
12/01/05	A	Initial Issue
12/07/05	B	Update D.C. Operating Characteristics
12/14/05	C	Update Pin Functions Update Ordering Information
03/06/06	D	Update Features Update Pin Configuration Update A.C. Characteristics Update Device Operation Update Package Dimensions Update Package Marking Update Tape and Reel
05/16/06	E	Update Pin Configuration Update D.C. Operating Characteristics Update A.C. Characteristics Update Device Operation Update Package Marking Update Tape and Reel
09/11/06	F	Update Features Update Description Update Pin Functions Update Functional Symbol Update Absolute Maximum Ratings Update Reliability Characteristics Update D.C. Operating Characteristics Update Pin Capacitance Update A.C. Characteristics Update Timing Diagrams Update Package Dimensions Remove Package Marking Update Ordering Information

Copyrights, Trademarks and Patents

Trademarks and registered trademarks of Catalyst Semiconductor include each of the following:

DPP™ AE²™ MiniPot™ Quad-Mode™

Catalyst Semiconductor has been issued U.S. and foreign patents and has patent applications pending that protect its products.

CATALYST SEMICONDUCTOR MAKES NO WARRANTY, REPRESENTATION OR GUARANTEE, EXPRESS OR IMPLIED, REGARDING THE SUITABILITY OF ITS PRODUCTS FOR ANY PARTICULAR PURPOSE, NOR THAT THE USE OF ITS PRODUCTS WILL NOT INFRINGE ITS INTELLECTUAL PROPERTY RIGHTS OR THE RIGHTS OF THIRD PARTIES WITH RESPECT TO ANY PARTICULAR USE OR APPLICATION AND SPECIFICALLY DISCLAIMS ANY AND ALL LIABILITY ARISING OUT OF ANY SUCH USE OR APPLICATION, INCLUDING BUT NOT LIMITED TO, CONSEQUENTIAL OR INCIDENTAL DAMAGES.

Catalyst Semiconductor products are not designed, intended, or authorized for use as components in systems intended for surgical implant into the body, or other applications intended to support or sustain life, or for any other application in which the failure of the Catalyst Semiconductor product could create a situation where personal injury or death may occur.

Catalyst Semiconductor reserves the right to make changes to or discontinue any product or service described herein without notice. Products with data sheets labeled "Advance Information" or "Preliminary" and other products described herein may not be in production or offered for sale.

Catalyst Semiconductor advises customers to obtain the current version of the relevant product information before placing orders. Circuit diagrams illustrate typical semiconductor applications and may not be complete.



Catalyst Semiconductor, Inc.

Corporate Headquarters

2975 Stender Way

Santa Clara, CA 95054

Phone: 408.542.1000

Fax: 408.542.1200

www.catsemi.com

Publication #: 1107

Revision: F

Issue date: 09/11/06