



SPECIFICATIONS

PART NAME : PIEZO SOUNDER

MODEL NO. : CBE1740BP-1

Signature of Approval

Signature of Dae young

Issued by	Check by	Approved	Date
			MAY. 15, 2011

SPECIFICATIONS

2
8

PART NAME	PIEZO SOUNDER	MODEL NO.	CBE1740BP-1	ISSUED DATE	MAY. 15, 2011
-----------	---------------	-----------	-------------	-------------	---------------

REVISION

Rev.No.	DATE	PAGE	DESCRIPTION	SIGN
		/		
		/		
		/		
		/		
		/		
		/		
		/		
		/		
		/		
		/		
		/		
		/		
		/		
		/		
		/		
		/		



SPECIFICATIONS

3

8

1. Application: This specification is applicable to piezo-sounder

2. Model no. : CBE1740BP-1

3. Characteristics. (at 25 °C)

PARAMETER	MODEL NO.	CBE1740BP-1	UNIT
Operating Temperature		-40 TO +85	°C
Sound Pressure		Min.90(at 9 Vp-p , 4KHz , 10cm)	dB
Resonant Frequency		4.0 ± 0.5	khz
Electrostatic capacitance		12,000pf ± 30% (at 1khz)	Pf
Input voltage		Max.30	V _{P-P}

4. Measurements.

4.1 Standard test conditions.

Temperature	25 ± 3	°C
Relative humidity	50 TO 70	%

4.2 Electrostatic capacitance.

Instrument	LCR meter (hp4276A)
Measuring conditions	1khz, 1vrms

SPECIFICATIONS

4

8

5. DIMENSIONS

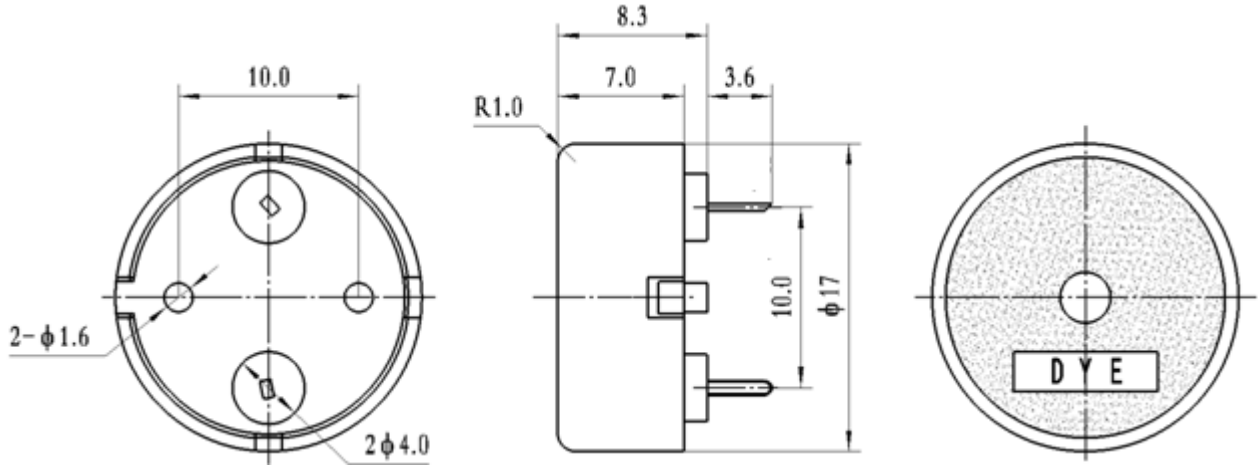

Tolerance: ± 0.5

6. STANDARD FREQUENCY RESPONSE CURVE(ONLY FOR REFERENCE)

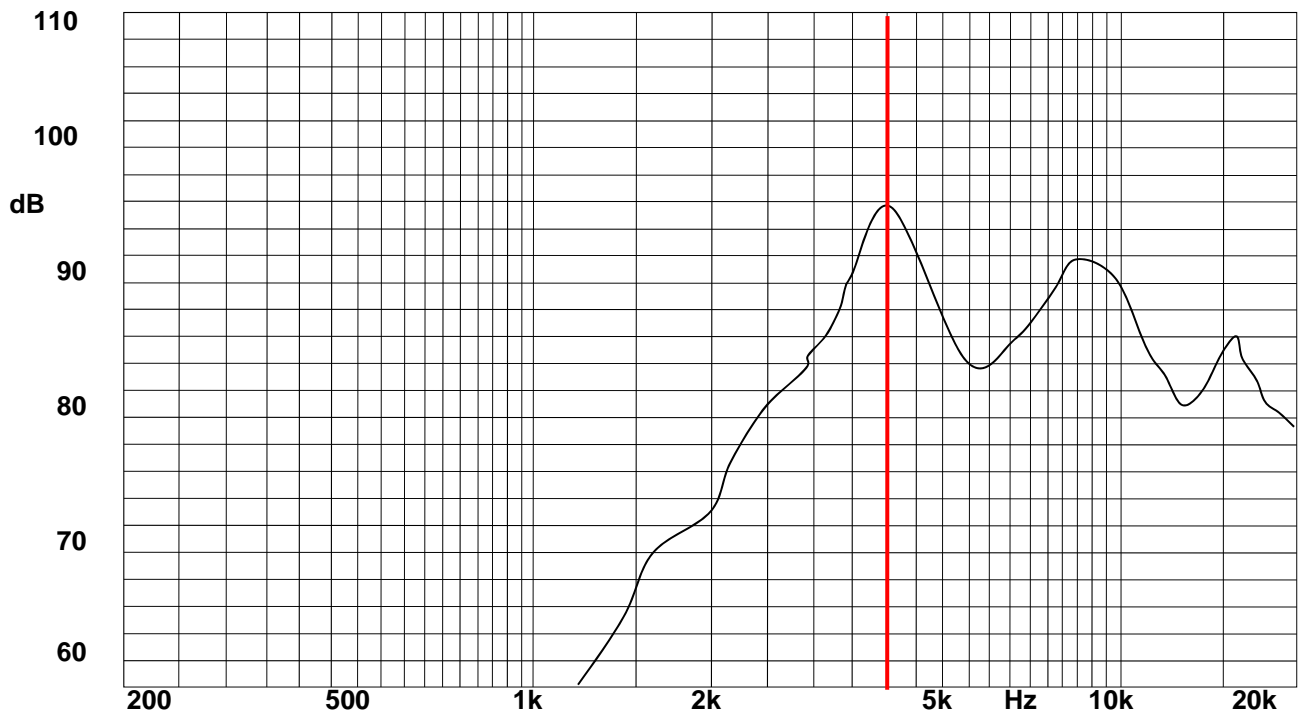

SPECIFICATIONS

5

8

7. Physical Characteristics.

	Item	Test Condition	Specification
7-1	Shock	Sounder shall be measured after being applied shock(980m/s ²) for each three mutually perpendicular directions to each of 3mes by half sine wave.	The measured value shall meet table 1.
7-2	Vibration Resistant	Sounder shall be measured after being applied vibration of 1.5mm p-p with 10 to 55hz band of vibration frequency to each of 3 perpendicular directions for 2 hours.	
7-3	Soldering Heat Resistance	Lead terminal are immersed up to 1.5mm from sounders body in solder bath of +300± 5°C for 3± 0.5 seconds or +260± 5°C for 10 ± 1 seconds, and then sounder shall be measured after being placed in natural condition for 4 hours.	
7-4	Solderability	Lead terminals are immersed in rosin for 5 seconds and then immersed in solder bath of +230± 5°C for 3±0.5 seconds.	90% min. lead terminals shall be wet with solder. (Except the edge of terminal)
7-5	Terminal Stength Pulling	The force 10 seconds of 9.8N is applied to each terminal in axial direction.	No visible damage and cutting off.

SPECIFICATIONS

6

8

8. Environmental Characteristics.

	Item	Test Condition	Specification
8-1	Dry Heat Test (Storage)	After being placed in a chamber with $+85 \pm 2^\circ\text{C}$ for 240 hours and then being placed in natural condition for 4 hours, sounder shall be measured.	The measured value shall meet table 1.
8-2	Cold Test (Storage)	After being placed in a chamber with $-40 \pm 2^\circ\text{C}$ for 240 hours and then being placed in natural condition for 4 hours, sounder shall be measured.	
8-3	Humidity	After being placed in a chamber with 90 to 95%R.H. at $+40 \pm 2^\circ\text{C}$ for 240 hours and then being placed in natural condition for 4 hours, sounder shall be measured.	
8-4	Temperature Cycle	After being placed in a chamber at $-40 \pm 2^\circ\text{C}$ for 30 minutes, sounder shall be placed at room temperature($+20^\circ\text{C}$). After 15 minutes at this temperature, sounder shall be placed in a chamber at $+85 \pm 2^\circ\text{C}$. After 30 minutes at this temperature, sounder shall be and returned to room temperature($+20^\circ\text{C}$) for 15 minutes. After 5 above cycles, sounder shall be measured after being placed in natural condition for 4 hours.	

SPECIFICATIONS

9. Measuring Method

9-1 S.P.L Measuring Circuit

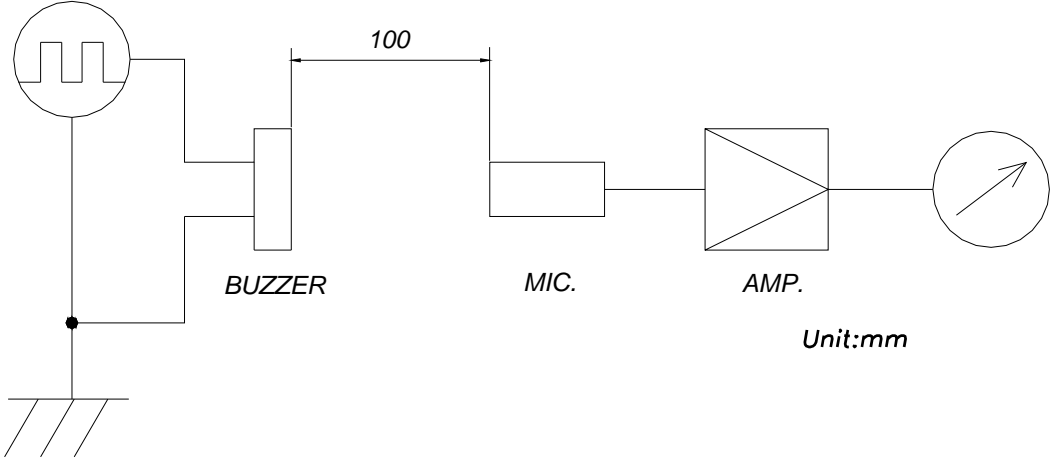
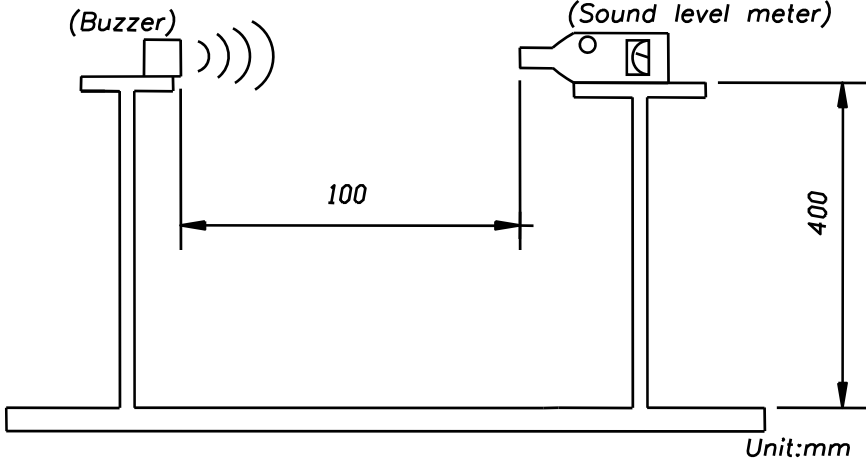

SPECIFICATIONS

8

8

10. Packing Information

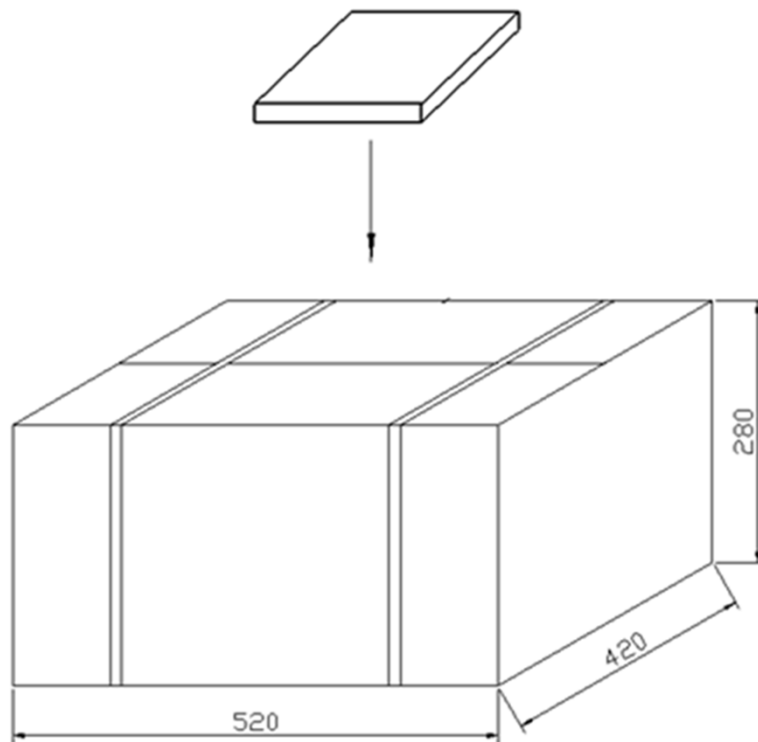

NOTES:

1. 100 PCS per tray
2. Total 50 trays per carton
3. Total 5000 PCS carton
4. Volume: $52 \times 42 \times 28$ cm