



电视伴音信号处理电路

1. 概述与特点

CD1353CP 是一块电视伴音信号处理中放电路，内部包含中频限幅放大、差动峰值鉴频、直流音量控制、音频电压放大和功率放大等电路单元。具有外围元件少，调整方便等特点，输出级工作电源电压范围为 9~18V。

其特点如下：

- 当 $V_{CC} = 18V$ 时， $P_O = 2.4W$
- 当 $V_{CC} = 12V$ 时， $P_O = 1.2W$
- 封装形式：FDIP14

2. 功能框图与引脚说明

2.1 功能框图

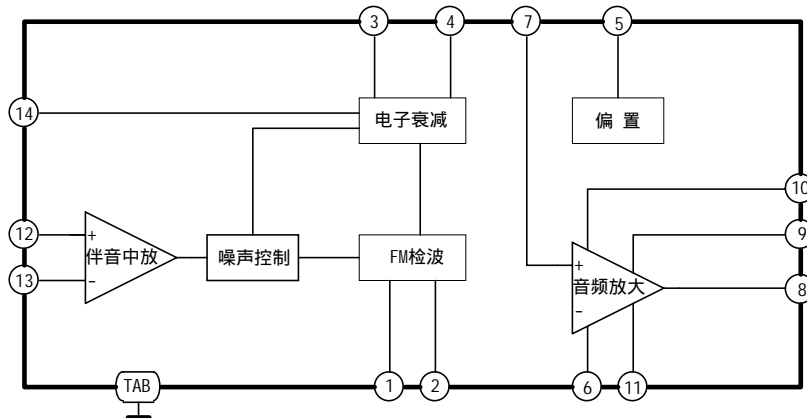

2.2 引脚说明

引脚	符号	功能	引脚	符号	功能
1	QUAD	鉴频	8	OUT _{AFP}	音频功放输出
2	QUAD	鉴频	9	BS	自举
3	DEM	去加重	10	V _{CC}	电源
4	OUT _{QUAD}	鉴频输出	11	NF	负反馈
5	V _{REG}	稳压源	12	IN _{SIP}	伴音中频输入
6	DC	退耦	13	IN _{SIP}	伴音中频输入
7	IN _{AFP}	音频功放输入	14	CON _{VOL}	音量控制

无锡华润矽科微电子有限公司

地址：江苏省无锡市梁溪路 14 号 电话：0510-85810118-5506 传真：0510-85810118-3093

邮编：214061

网址：<http://www.semico.com.cn>

电邮：apply@semico.com.cn



3. 电特性

3.1 极限参数

除非另有规定, $T_{amb}=25^{\circ}\text{C}$

参数名称	符号	条件	额定值	单位
电源电压	V_{CC}		20	V
10脚电流	I_{10}		1	A
5脚电流	I_5		100	mA
输入信号电压	V_i		3	V_{pp}
功耗	P_{D1}		0.8	W
	P_{D2}	印刷版铜箔 $50 \times 50\text{mm}^2$, 板厚 1.6mm	1.4	W
工作环境温度	T_{amb}		-20 ~ 75	$^{\circ}\text{C}$
贮存温度	T_{stg}		-40 ~ 150	$^{\circ}\text{C}$

3.2 电特性

除非另有规定, $T_{amb}=25^{\circ}\text{C} \pm 3^{\circ}\text{C}$, $V_{CC}=12\text{V}$, $R_B=100\Omega$, $f_m=400\text{Hz}$

参数名称	符号	测试条件	规范值			单位
			最小	典型	最大	
中频部分: $R_g=50\Omega$, $f_o=6.5\text{MHz}$, $\Delta f=\pm 25\text{kHz}$, $V_{14}=1.3\text{V}$ 以上						
5端电压	V_{5A}	$V_{14}=0\text{V}$	7.5	8.0	8.5	V
5端电压	V_{5B}	$V_{CC}=18\text{V}$, $V_{14}=0\text{V}$ $R_B=330\Omega$	7.5	8.0	8.5	V
10端电流	I_{10A}	无信号时	14	19	24	mA
10端电流	I_{10B}	$V_{CC}=18\text{V}$ 无信号时, $R_B=330\Omega$	16	28	35	mA
输入限幅灵敏度	$V_{IN(LIM)}$	VOD ($V_I=10\text{mV}$) 的-3dB		200	400	μV
检波输出电压	V_{OD}	$V_I=10\text{mV}$	250	360		mV
全谐波失真度 1	THD1	$V_I=10\text{mV}$		0.7		%
调幅抑制比	AMR	$V_I=10\text{mV}$, AM: $m=0.3$ $f_m=400\text{Hz}$	-40	-50		dB
最大衰减量	ATT_{MAX}	V_{14} 为 1.6V 与 0V 时 4端输出比	-60	-80		dB

接下表



5. 应用线路

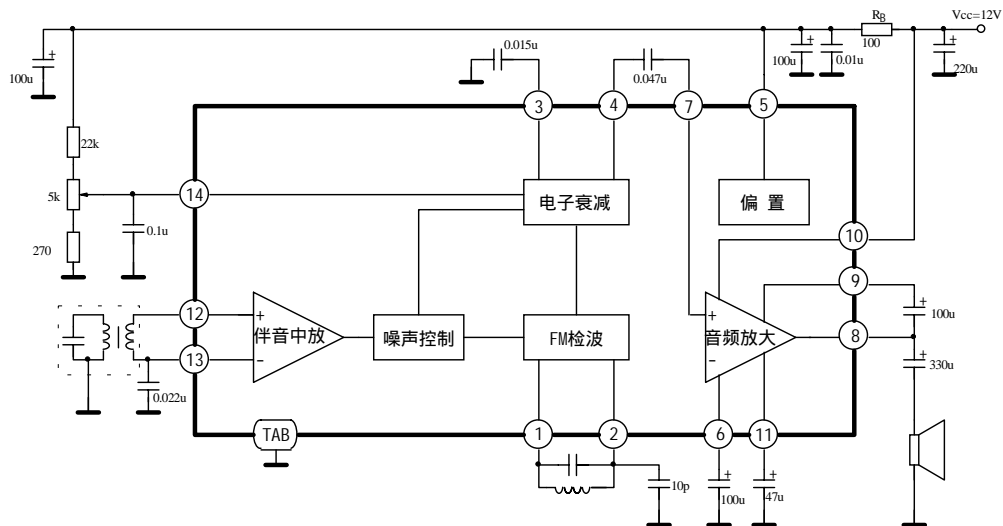

6. 外形尺寸

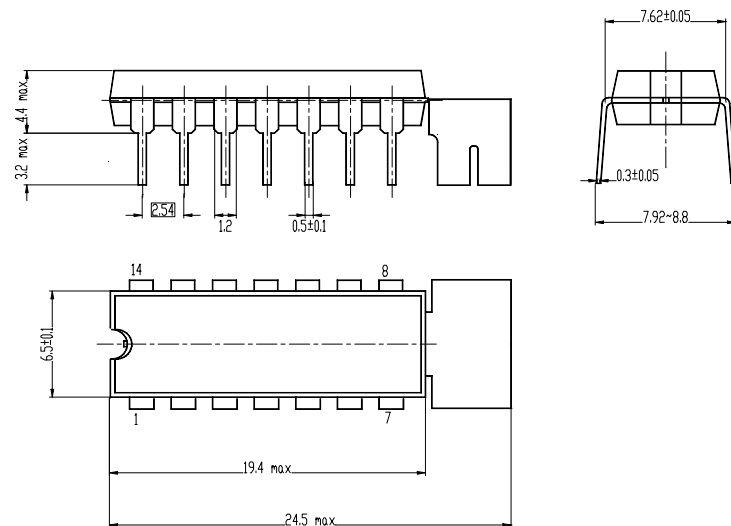



2.4W AUDIO AMPLIFIER, SIF AMPLIFIER AND DETECTOR FOR TV SILICON MONOLITHIC BIPOLAR INTEGRATED CIRCUIT CD1353CP

DESCRIPTION

The CD1353CP is a silicon monolithic integrated circuit designed for SIF and Audio section in television receivers. This IC has all functions including sound IF Amplifier, FM Detector, DC volume control circuit, Audio Output amplifier with 2.4W output power and voltage regulator.

This IC is encapsulated in 14pin dual in-line package with heat tab.

Outline Drawing

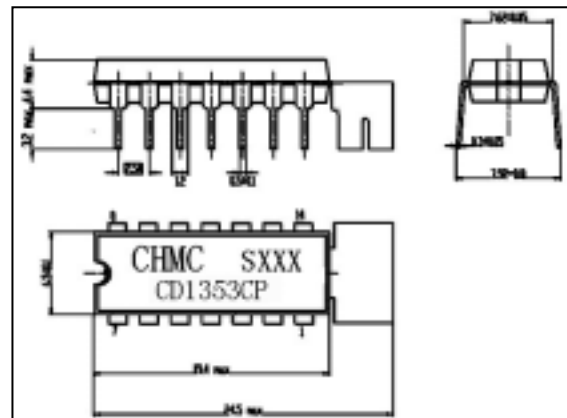

FEATURES:

- All functions for SIF and audio stage are provided by this one-chip IC and this IC will realize reduction of assembly cost as well as reduction of number of other components.
- Audio output power is controlled by electronic attenuation circuit which operate at DC. Therefore, unnecessary radiation, oscillation etc. are eliminated. Due to DC control, shielded wire is not required and variable resistor will be placed anywhere required.
- Electronic attenuator has enough attenuation (Typ.80dB) by the adoption of squelch circuit. In addition, as attenuation characteristic is same with resistance change of variable resistor, suitable variable resistor will be selected easily.
- As Peak differential detection method is adopted for FM detection, outside circuitry can be very simple easy.
- As operation voltage (V_{cc}) range for output stage is very wide (9-18V), suitable V_{cc} can be freely determined for required output level.

For example:

$P_o=2.4W$ at $V_{cc}=18V$, $R_L=8$

$P_o=1.2W$ at $V_{cc}=12V$, $R_L=8$

BLOCK DIAGRAM

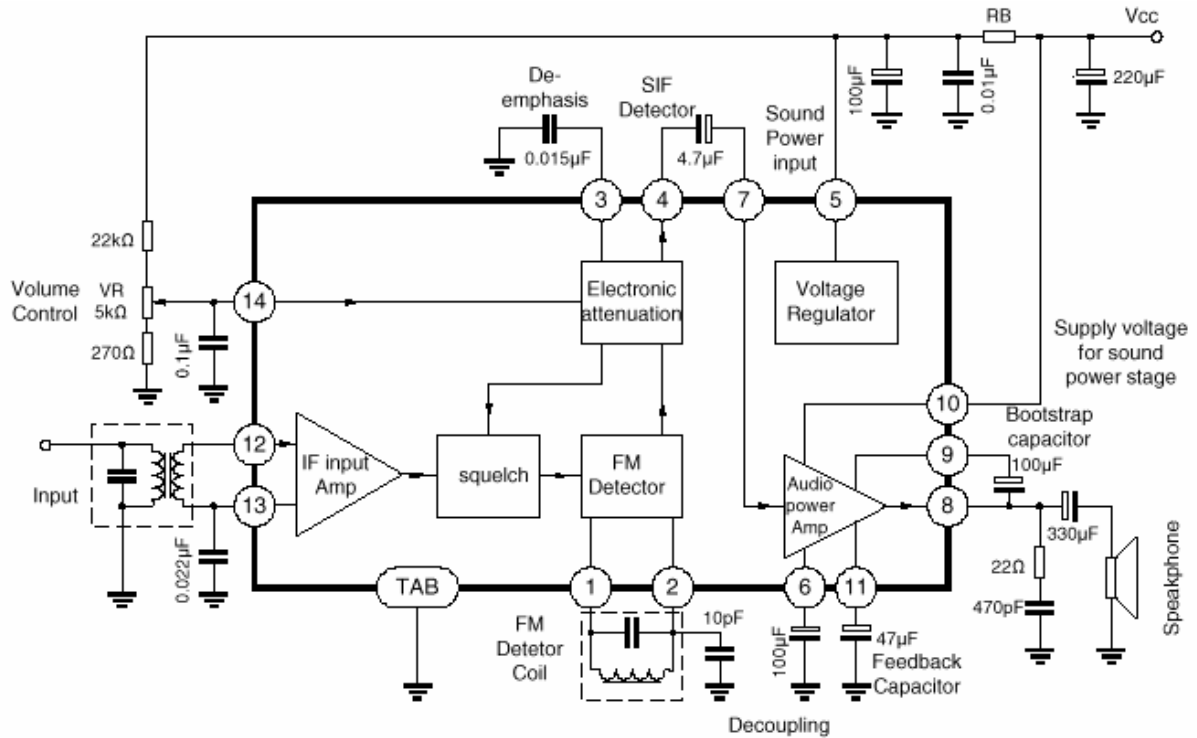

PIN CONNECTION

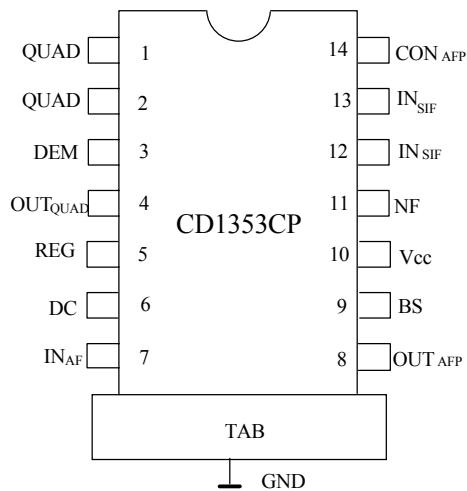

PIN DESCRIPTION

Pin	Description	Symbol	Pin	Description	Symbol
1	FM Detector Coil	QUAD	8	Sound Power Out	OUT _{AFP}
2	FM Detector Coil	QUAD	9	Bootstrap Capacitor	BS
3	DE Emphasis Capacitor	DEM	10	Supply Voltage For Sound Power Stage	V _{cc}
4	SIF Detector Output	OUT _{QUAD}	11	Feed Back Capacitor	NF
5	Supply Voltage For SIF Stage	REG	12	SIF Input (Hot End)	IN _{SIF}
6	Decoupling Capacitor	DC	13	SIF Input (Cold End)	IN _{SIF}
7	Sound Power Input	IN _{AF}	14	Volume Control	CON _{VOL}

ABSOLUTE MAXIMUM RATINGS (Ta=25°C)

Characteristic	Symbol	Value	Unit
Supply Voltage Pin 10	V ₁₀	20	V
Supply Current Pin 10	I ₁₀	1	A
Supply Current Pin 5	I ₅	100	mA
Input Signal Voltage	V _i	3	V _{p-p}
Power Dissipation	P _{d1}	0.8(Ta=75°C) Free Air	W
Power Dissipation	P _{d2}	1.4*	W
Operating Temperature	T _{opt}	-20 to +75	°C
Storage Temperature	T _{stg}	-40 to +150	°C

- Printed Circuit copper Area 50×50mm²

ELECTRICAL CHARACTERISTICS (Ta=25±3°C)

Characteristic	Symbol	Test Condition	Min	Typ	Max	Unit
If Stage (Vcc=12V RB=100Ω Rg=50Ω V14≥1.3V fo=4.5MHz fM=400Hz f=±25kHz)						
Pin 5 Voltage	V5A		7.5	8.0	8.5	V
Pin 5 Voltage	V5B	Vcc=18V RB=330Ω	7.5	8.0	8.5	V
Pin 10 Current	I10A	No Input Signal	14	19	24	mA
Pin 10 Current	I10B	Vcc=18V RB=330Ω No Input Signal	16	28	35	mA
IF Limiting Voltage	Vi(lim)	VOAF(Vi=10mVrms)-3dB		200	400	μVrms
Detector Output Voltage	VOD	Vi=10mVrms	300	360		mVrms
Detector Distortion	THD1	Vi=10mVrms		0.7		%
AM Rejection	AMR	AM MOD 30% fM=400Hz Vi=10mVrms	-40	-50		dB
Maximum Attenuation	ATTMAX	V14=0V	-60	-80		dB
Sound Power Stage (vcc=12V RB=100Ω RL=8Ω f=400Hz Rg=600Ω)						
Sound Stage Voltage Gain	Av	Vi=30mVrms	33	37	41	dB
Sound Output Power	PO1	THD=10%	0.9	1.2		W
Sound Output Power	PO2	Vcc=18V RB=330Ω THD=10%	2.0	2.4		W
Sound Output Distortion	THD2	Po=0.5W		0.6	2.0	%
Sound Output Distortion	THD3	Vcc=18V RB=330Ω Po=0.5W		0.5	2.0	%
If Stage + Sound Power Stage						
Over All Sound Output Distortion	THD4	Po=0.5W Vi=10mVrms		1.5	4.0	%
Reference Data						
Pin 10 Current	I10	THD.2A=10%	200		210	mA
Pin 10 Current	I10	THD.2B=10%	270		280	mA
Sound Output Power	PO1	THD=3%		1.1		W
Sound Output Power	PO2	Vcc=18V RB=330Ω THD=3%		2.0		W
Sound Stage Band Width	BW	-3dB	50		50k	Hz

Pin Impedance	fo=4.5MHz		5.5MHz		6.0MHz		6.5MHz		Unit
	R	C	R	C	R	C	R	C	
Pin 12 IF Input	2	9.5	2	9.4	1.9	9.4	1.9	9.4	kΩ/pF
Pin 1 Detector Connect	2.4	6.3	2.4	6.2	2.4	6.1	2.4	6.1	kΩ/pF
Pin2 Detector Connect	11.5	9	9	8.5	8.5	8.3	7.8	8.1	kΩ/pF

TEST CIRCUIT

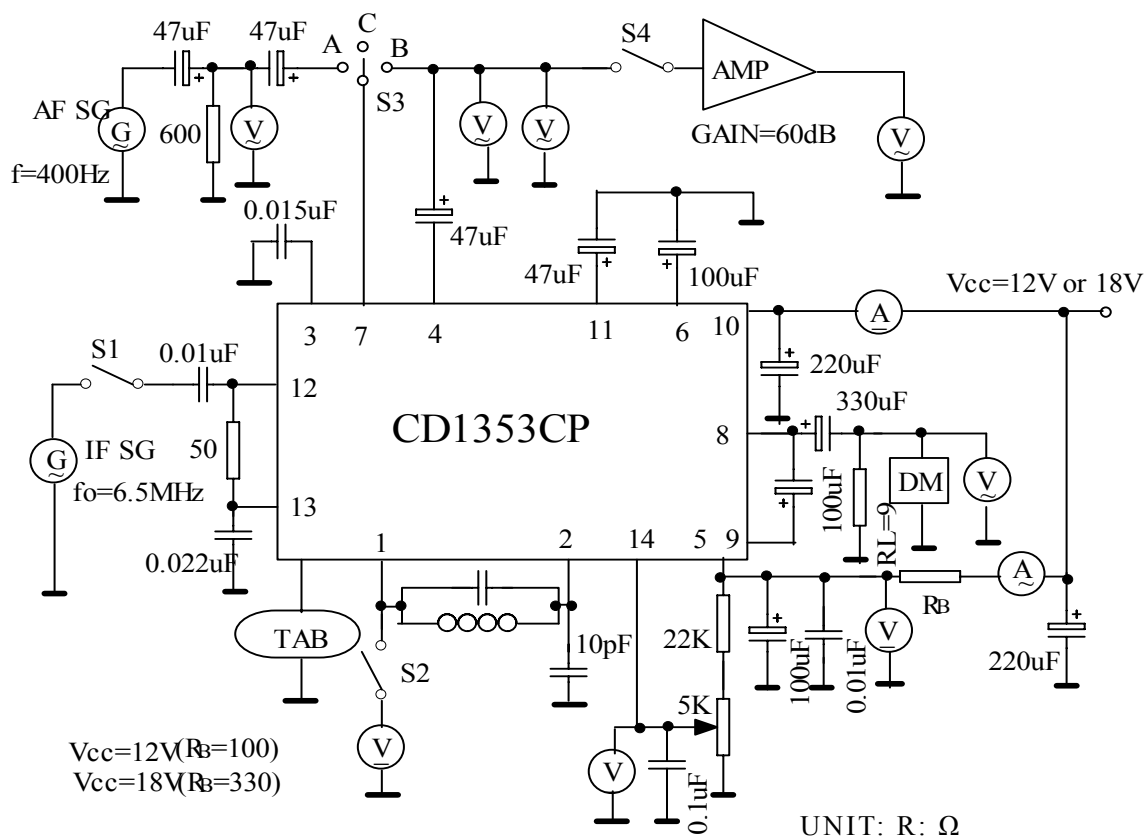

TEST SWITCH SITUATION TABLE

Characteristics	S1	S2	S3	S4	Characteristics	S1	S2	S3	S4
V _{5A}	off	off	C	off	ATT _{MAX}	on	off	B	off→on
V _{5B}	off	off	C	off	A _v	off	off	A	off
I _{10A}	off	off	C	off	P _{o1}	off	off	A	off
I _{10B}	off	off	C	off	P _{o2}	off	off	A	off
V _{i(lim)}	on	off	B	off	THD ₂	off	off	A	off
V _{OD}	on	off	B	off	THD ₃	off	off	A	off
THD ₁	on	off	B	off	THD ₄	on	off	C	off
AMR	on	off	B	off					

APPLICATION CIRCUIT

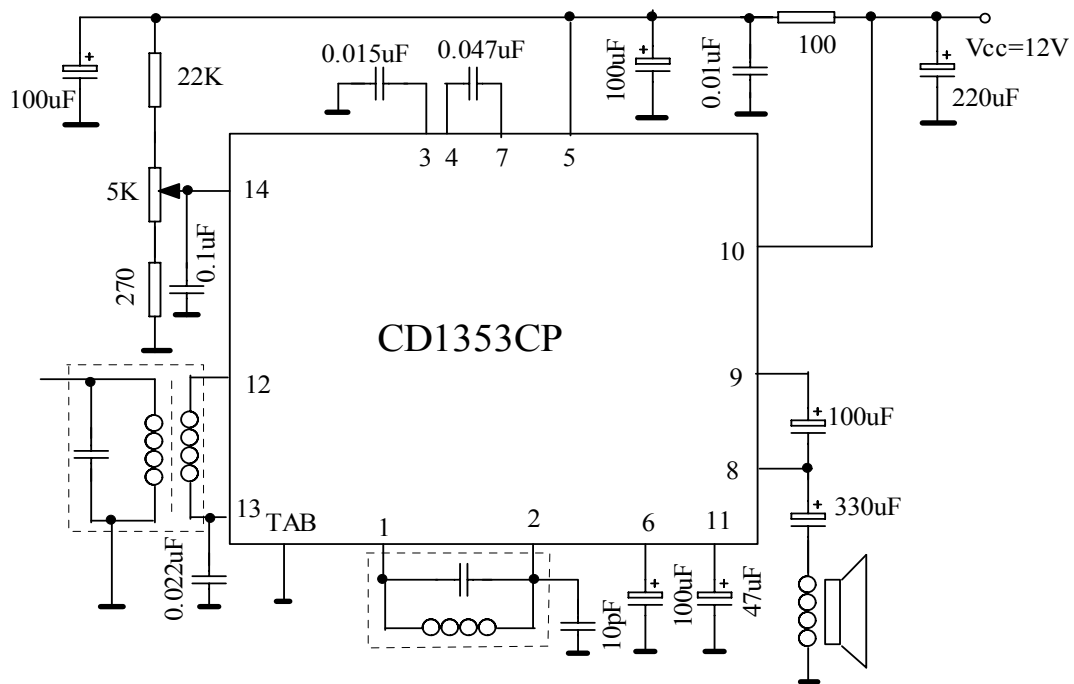

UNIT: R:Ω

CHARACTERISTICS CURVES

