

## CD4008BM/CD4008BC 4-Bit Full Adder

### General Description

The CD4008B types consist of four full-adder stages with fast look-ahead carry provision from stage to stage. Circuitry is included to provide a fast "parallel-carry-out" bit to permit high-speed operation in arithmetic sections using several CD4008B's. CD4008B inputs include the four sets of bits to be added, A1 to A4 and B1 to B4, in addition to the "Carry in" bit from a previous section. CD4008B outputs include the four sum bits, S1 and S4, in addition to the high-speed "parallel-carry-out" which may be utilized at a succeeding CD4008B section.

All inputs are protected from damage due to static discharge by diode clamps to  $V_{DD}$  and GND.

### Features

- Wide supply voltage range 3.0V to 15V
- High noise immunity 0.45  $V_{CC}$  (typ.)
- Low power TTL compatibility Fan out of 2 driving 74L or 1 driving 74LS
- 4 sum outputs plus parallel look-ahead carry-output
- Quiescent current specified to 15V
- Maximum input leakage of 1  $\mu A$  at 15V (full package temperature range)

### Block Diagram

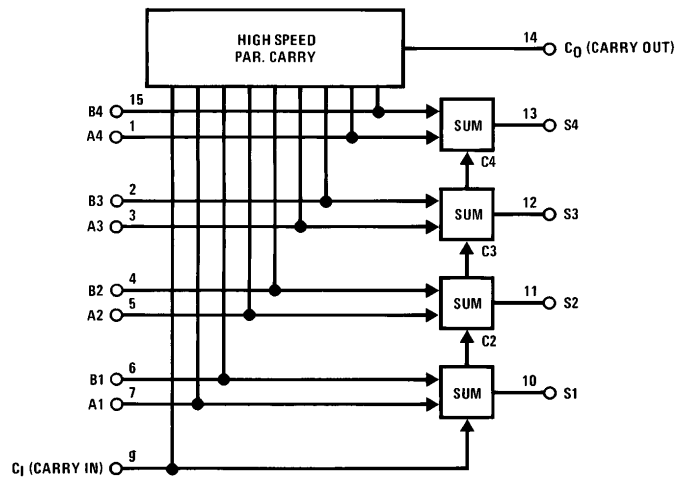

### Truth Table

$A_i$	$B_i$	$C_i$	$C_0$	SUM
0	0	0	0	0
1	0	0	0	1
0	1	0	0	1
1	1	0	1	0
0	0	1	0	1
1	0	1	1	0
0	1	1	1	0
1	1	1	1	1

TL/F/5944-1

### Connection Diagram

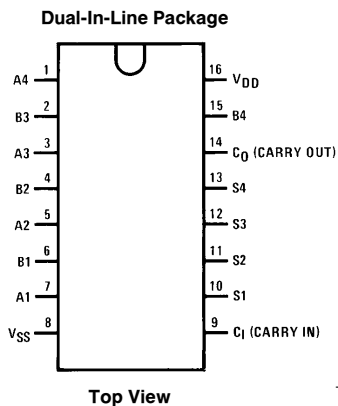

Order Number CD4008B

TL/F/5944-2

### Absolute Maximum Ratings (Notes 1 & 2)

If Military/Aerospace specified devices are required, please contact the National Semiconductor Sales Office/Distributors for availability and specifications.

DC Supply Voltage ( $V_{DD}$ )	-0.5V to +18 $V_{DC}$
Input Voltage ( $V_{IN}$ )	-0.5V to $V_{DD}$ + 0.5 $V_{DC}$
Storage Temperature Range ( $T_S$ )	-65°C to +150°C
Power Dissipation ( $P_D$ )	
Dual-In-Line	700 mW
Small Outline	500 mW
Lead Temperature, ( $T_L$ )	
(Soldering, 10 seconds)	260°C

### Recommended Operating Conditions (Note 2)

DC Supply Voltage ( $V_{DD}$ )	3 to 15 $V_{DC}$
Input Voltage ( $V_{IN}$ )	0 to $V_{DD}$ $V_{DC}$
Operating Temperature Range ( $T_A$ )	
CD4008BM	-55°C to +125°C
CD4008BC	-40°C to +85°C

### DC Electrical Characteristics CD4008BM (Note 2)

Symbol	Parameter	Conditions	-55°C		+25°C			+125°C		Units
			Min	Max	Min	Typ	Max	Min	Max	
$I_{DD}$	Quiescent Device Current	$V_{DD} = 5V, V_{IN} = V_{DD}$ or $V_{SS}$		5		0.3	5		150	$\mu A$
		$V_{DD} = 10V, V_{IN} = V_{DD}$ or $V_{SS}$		10		0.5	10		300	$\mu A$
		$V_{DD} = 15V, V_{IN} = V_{DD}$ or $V_{SS}$		20		1.0	20		600	$\mu A$
$V_{OL}$	Low Level Output Voltage	$ I_O  < 1 \mu A$ $V_{DD} = 5V$		0.05		0	0.05		0.05	V
		$V_{DD} = 10V$		0.05		0	0.05		0.05	V
		$V_{DD} = 15V$		0.05		0	0.05		0.05	V
$V_{OH}$	High Level Output Voltage	$ I_O  < 1 \mu A$ $V_{DD} = 5V$	4.95		4.95	5		4.95		V
		$V_{DD} = 10V$	9.95		9.95	10		9.95		V
		$V_{DD} = 15V$	14.95		14.95	15		14.95		V
$V_{IL}$	Low Level Input Voltage	$ I_O  < 1 \mu A$ $V_{DD} = 5V, V_O = 0.5V$ or $4.5V$		1.5			1.5		1.5	V
		$V_{DD} = 10V, V_O = 1V$ or $9V$		3.0			3.0		3.0	V
		$V_{DD} = 15V, V_O = 1.5V$ or $13.5V$		4.0			4.0		4.0	V
$V_{IH}$	High Level Input Voltage	$ I_O  < 1 \mu A$ $V_{DD} = 5V, V_O = 0.5V$ or $4.5V$	3.5		3.5			3.5		V
		$V_{DD} = 10V, V_O = 1V$ or $9V$	7.0		7.0			7.0		V
		$V_{DD} = 15V, V_O = 1.5V$ or $13.5V$	11.0		11.0			11.0		V
$I_{OL}$	Low Level Output Current (Note 3)	$V_{DD} = 5V, V_O = 0.4V$	0.64		0.51	0.88		0.36		mA
		$V_{DD} = 10V, V_O = 0.5V$	1.6		1.3	2.25		0.9		mA
		$V_{DD} = 15V, V_O = 1.5V$	4.2		3.4	8.8		2.4		mA
$I_{OH}$	High Level Output Current (Note 3)	$V_{DD} = 5V, V_O = 4.6V$	-0.25		-0.2	-0.35		-0.14		mA
		$V_{DD} = 10V, V_O = 9.5V$	-0.62		-0.5	-0.8		-0.35		mA
		$V_{DD} = 15V, V_O = 13.5V$	-1.8		-1.5	-3.5		-1.1		mA
$I_{IN}$	Input Current	$V_{DD} = 15V, V_{IN} = 0V$		-0.1		$-10^{-5}$	-0.1		-1.0	$\mu A$
		$V_{DD} = 15V, V_{IN} = 15V$		0.1		$10^{-5}$	0.1		1.0	$\mu A$

### DC Electrical Characteristics CD4008BC (Note 2)

Symbol	Parameter	Conditions	-40°C		+25°C			+85°C		Units
			Min	Max	Min	Typ	Max	Min	Max	
$I_{DD}$	Quiescent Device Current	$V_{DD} = 5V, V_{IN} = V_{DD}$ or $V_{SS}$		20		0.5	20		150	$\mu A$
		$V_{DD} = 10V, V_{IN} = V_{DD}$ or $V_{SS}$		40		1	40		300	$\mu A$
		$V_{DD} = 15V, V_{IN} = V_{DD}$ or $V_{SS}$		80		5	80		600	$\mu A$
$V_{OL}$	Low Level Output Voltage	$ I_O  < 1 \mu A$ $V_{DD} = 5V$		0.05		0	0.05		0.05	V
		$V_{DD} = 10V$		0.05		0	0.05		0.05	V
		$V_{DD} = 15V$		0.05		0	0.05		0.05	V
$V_{OH}$	High Level Output Voltage	$ I_O  < 1 \mu A$ $V_{DD} = 5V$	4.95		4.95	5		4.95		V
		$V_{DD} = 10V$	9.95		9.95	10		9.95		V
		$V_{DD} = 15V$	14.95		14.95	15		14.95		V

## DC Electrical Characteristics CD4008BC (Note 2) (Continued)

Symbol	Parameter	Conditions	-40°C		+25°C			+85°C		Units
			Min	Max	Min	Typ	Max	Min	Max	
V <sub>IL</sub>	Low Level Input Voltage	I <sub>O</sub>   < 1 μA V <sub>DD</sub> = 5V, V <sub>O</sub> = 0.5V or 4.5V V <sub>DD</sub> = 10V, V <sub>O</sub> = 1V or 9V V <sub>DD</sub> = 15V, V <sub>O</sub> = 1.5V or 13.5V		1.5			1.5		1.5	V
				3.0			3.0		3.0	V
				4.0			4.0		4.0	V
V <sub>IH</sub>	High Level Input Voltage	I <sub>O</sub>   < 1 μA V <sub>DD</sub> = 5V, V <sub>O</sub> = 0.5V or 4.5V V <sub>DD</sub> = 10V, V <sub>O</sub> = 1V or 9V V <sub>DD</sub> = 15V, V <sub>O</sub> = 1.5V or 13.5V	3.5		3.5			3.5		V
			7.0		7.0			7.0		V
			11.0		11.0			11.0		V
I <sub>OL</sub>	Low Level Output Current (Note 3)	V <sub>DD</sub> = 5V, V <sub>O</sub> = 0.4V V <sub>DD</sub> = 10V, V <sub>O</sub> = 0.5V V <sub>DD</sub> = 15V, V <sub>O</sub> = 1.5V	0.52		0.44	0.88		0.36		mA
			1.3		1.1	2.25		0.9		mA
			3.6		3.0	8.8		2.4		mA
I <sub>OH</sub>	High Level Output Current (Note 3)	V <sub>DD</sub> = 5V, V <sub>O</sub> = 4.6V V <sub>DD</sub> = 10V, V <sub>O</sub> = 9.5V V <sub>DD</sub> = 15V, V <sub>O</sub> = 13.5V	-0.2		-0.16	-0.35		-0.12		mA
			-0.5		-0.4	-0.8		-0.3		mA
			-1.4		-1.2	-3.5		-1.0		mA
I <sub>IN</sub>	Input Current	V <sub>DD</sub> = 15V, V <sub>IN</sub> = 0V V <sub>DD</sub> = 15V, V <sub>IN</sub> = 15V		-0.3			-0.3		-1.0	μA
				0.3			0.3		1.0	μA

## AC Electrical Characteristics\*

T<sub>A</sub> = 25°C, C<sub>L</sub> = 50 pF, R<sub>L</sub> = 200k, input t<sub>r</sub>, t<sub>f</sub> = 20 ns, unless otherwise specified.

Symbol	Parameter	Conditions	Min	Typ	Max	Units	
t <sub>PHL</sub> or t <sub>PLH</sub>	Propagation Delay Time Sum In to Sum Out	V <sub>DD</sub> = 5V		425	750	ns	
		V <sub>DD</sub> = 10V		170	250	ns	
		V <sub>DD</sub> = 15V		125	190	ns	
	Carry In to Sum Out	V <sub>DD</sub> = 5V		320	650	ns	
		V <sub>DD</sub> = 10V		125	225	ns	
		V <sub>DD</sub> = 15V		95	175	ns	
	Sum In to Carry Out	V <sub>DD</sub> = 5V		250	500	ns	
		V <sub>DD</sub> = 10V		115	200	ns	
		V <sub>DD</sub> = 15V		90	160	ns	
	Carry In to Carry Out	V <sub>DD</sub> = 5V		130	245	ns	
		V <sub>DD</sub> = 10V		60	105	ns	
		V <sub>DD</sub> = 15V		45	80	ns	
	Carry In to Carry Out	C <sub>L</sub> = 15 pF	V <sub>DD</sub> = 5V		100	175	ns
			V <sub>DD</sub> = 10V		45	75	ns
			V <sub>DD</sub> = 15V		35	60	ns
t <sub>THL</sub>	High-to-Low Transition Time	V <sub>DD</sub> = 5V		100	200	ns	
		V <sub>DD</sub> = 10V		50	100	ns	
		V <sub>DD</sub> = 15V		40	80	ns	
t <sub>TLH</sub>	Low-to-High Transition Time	V <sub>DD</sub> = 5V		200	400	ns	
		V <sub>DD</sub> = 10V		100	200	ns	
		V <sub>DD</sub> = 15V		80	160	ns	
C <sub>IN</sub>	Average Input Capacitance			5	7.5	pF	
C <sub>PD</sub>	Power Dissipation Capacitance	(Note 4)		100		pF	

\*AC Parameters are guaranteed by DC correlated testing.

**Note 1:** "Absolute Maximum Ratings" are those values beyond which the safety of the device cannot be guaranteed; they are not meant to imply that the devices should be operated at these limits. The table of "Recommended Operating Conditions" and "Electrical Characteristics" provides conditions for actual device operation.

**Note 2:** V<sub>SS</sub> = 0V unless otherwise specified.

**Note 3:** I<sub>OH</sub> and I<sub>OL</sub> are tested one output at a time.

**Note 4:** C<sub>PD</sub> determines the no load AC power consumption of any CMOS device. For complete explanation, see 54C/74C Family Characteristics application note, AN-90.

## AC Test Circuit and Switching Time Waveforms

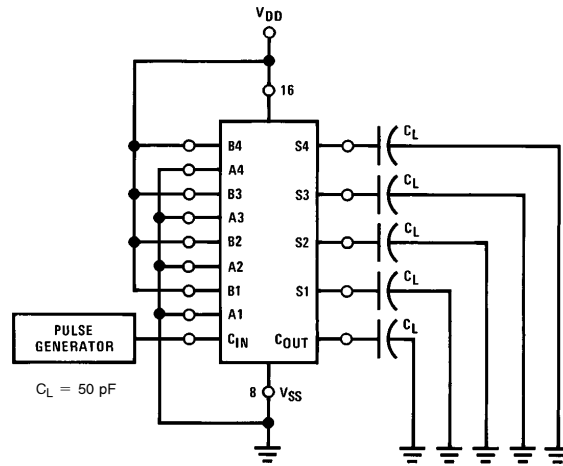

TL/F/5944-3

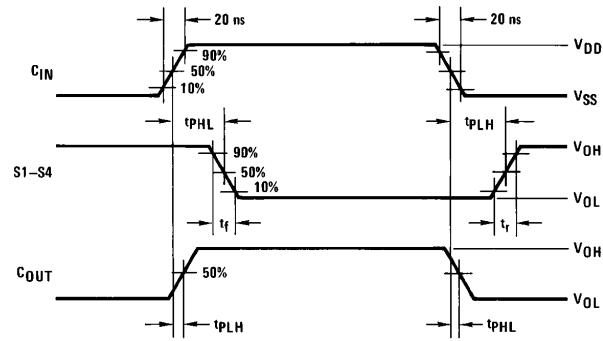

TL/F/5944-4

**Physical Dimensions** inches (millimeters)

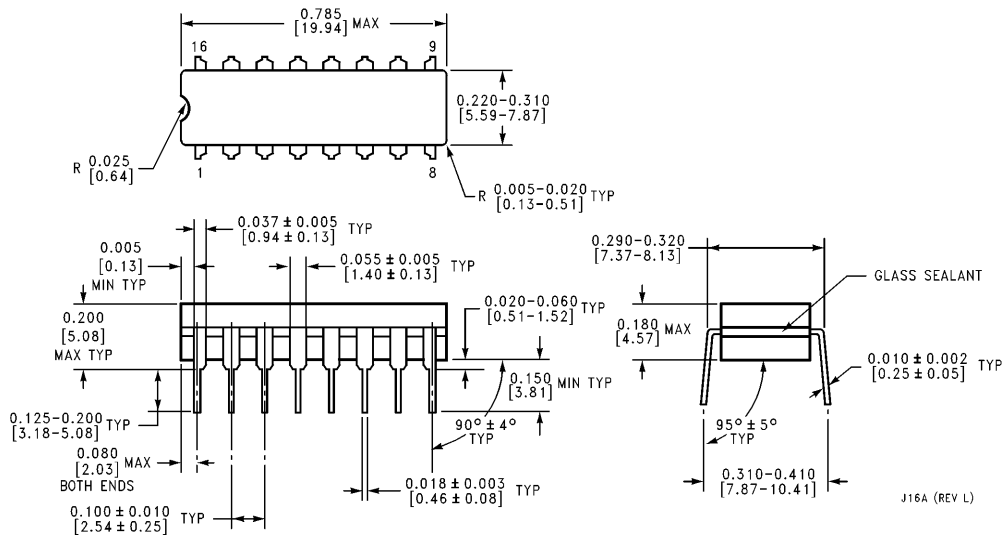

**Ceramic Dual-In-Line Package (J)**  
**Order Number CD4008BMJ or CD4008BCJ**  
**NS Package Number J16A**

J16A (REV L)

**Physical Dimensions** inches (millimeters) (Continued)

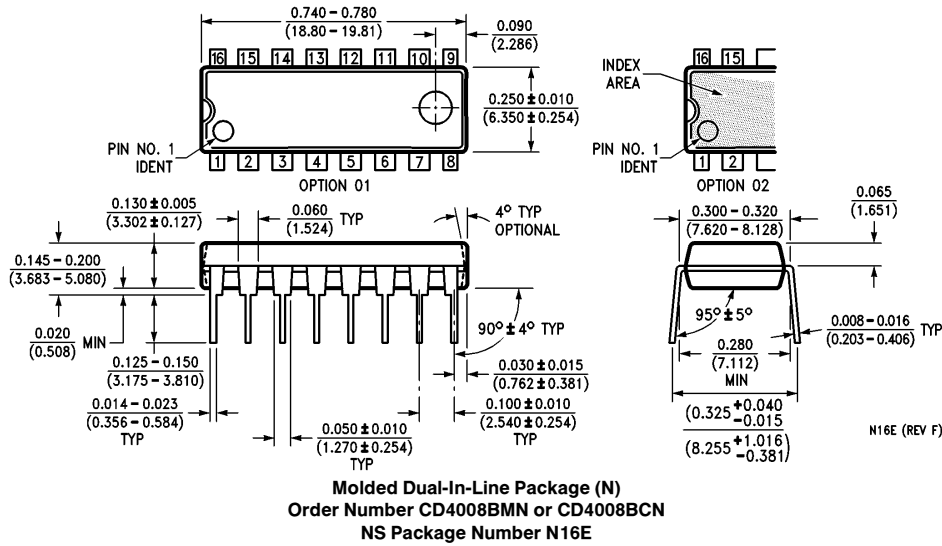

**LIFE SUPPORT POLICY**

NATIONAL'S PRODUCTS ARE NOT AUTHORIZED FOR USE AS CRITICAL COMPONENTS IN LIFE SUPPORT DEVICES OR SYSTEMS WITHOUT THE EXPRESS WRITTEN APPROVAL OF THE PRESIDENT OF NATIONAL SEMICONDUCTOR CORPORATION. As used herein:

1. Life support devices or systems are devices or systems which, (a) are intended for surgical implant into the body, or (b) support or sustain life, and whose failure to perform, when properly used in accordance with instructions for use provided in the labeling, can be reasonably expected to result in a significant injury to the user.
2. A critical component is any component of a life support device or system whose failure to perform can be reasonably expected to cause the failure of the life support device or system, or to affect its safety or effectiveness.



**National Semiconductor Corporation**  
 1111 West Bardin Road  
 Arlington, TX 76017  
 Tel: 1(800) 272-9959  
 Fax: 1(800) 737-7018

**National Semiconductor Europe**  
 Fax: (+49) 0-180-530 85 86  
 Email: cnjwge@tevm2.nsc.com  
 Deutsch Tel: (+49) 0-180-530 85 85  
 English Tel: (+49) 0-180-532 78 32  
 Français Tel: (+49) 0-180-532 93 58  
 Italiano Tel: (+49) 0-180-534 16 80

**National Semiconductor Hong Kong Ltd.**  
 19th Floor, Straight Block,  
 Ocean Centre, 5 Canton Rd.  
 Tsimshatsui, Kowloon  
 Hong Kong  
 Tel: (852) 2737-1600  
 Fax: (852) 2736-9960

**National Semiconductor Japan Ltd.**  
 Tel: 81-043-299-2309  
 Fax: 81-043-299-2408

National does not assume any responsibility for use of any circuitry described, no circuit patent licenses are implied and National reserves the right at any time without notice to change said circuitry and specifications.