

# CD4543B Types

## CMOS BCD-to-Seven-Segment Latch/Decoder/Driver For Liquid-Crystal Displays

High-Voltage Types (20-Volt Rating)

**Features:**

- Display blanking of all illegal input combinations
- Latch storage of code
- Capability of driving two low power TTL loads, two HTL loads, or one low power Schottky load over the full rated-temperature range
- Pin-for-pin replacement for the CD4056B (with pin 7 tied to V<sub>SS</sub>)
- Direct LED driving capability

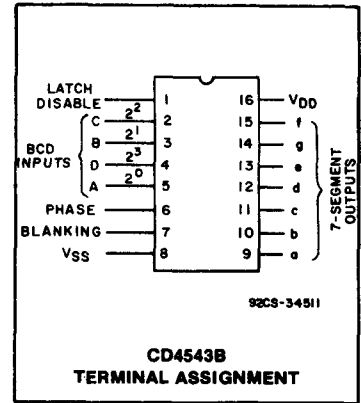

The RCA-CD4543B is a BCD-to-seven segment latch/decoder/driver designed primarily for liquid-crystal display (LCD) applications. It is also capable of driving light emitting diode (LED), incandescent, gas-discharge, and fluorescent displays. This device is functionally similar to and serves as direct replacement for the CD4056B when pin 7 is connected to V<sub>SS</sub>. It differs from the CD4056B in that it has a display blanking capability instead of a level-shifting function and requires only one power supply. When the CD4056B is used in the level shifting mode, two power supplies are required. When the CD4543B is used for LCD applications, a square wave must be applied to the PHASE input and the backplane of the LCD device. For LED applications a logic 1 is required at the PHASE input for common-cathode devices; a logic 0 is required for common-anode devices (see truth table).

The CD4543B is supplied in hermetic dual-in-line ceramic packages (D and F suffixes), 16-lead dual-in-line plastic packages (E suffix), 16-lead ceramic flat packages (K suffix), and in chip form (H suffix).

- 100% tested for quiescent current at 20 V
- Maximum input current of 1 μA at 18 V over full package-temperature range; 100 nA at 18 V and 25°C
- Noise margin (full package-temperature range) = 1 V at V<sub>DD</sub>=5 V  
2 V at V<sub>DD</sub>=10 V  
2.5 V at V<sub>DD</sub>=15 V
- 5-V, 10-V, and 15-V parametric ratings
- Meets all requirements of JEDEC Tentative Standard No. 13B, "Standard Specifications for Description of 'B' Series CMOS Devices"

**Applications:**

- Instrument display driver
- Dashboard display driver
- Computer/calculator display driver
- Timing device driver (clocks, watches, timers)

**MAXIMUM RATINGS, Absolute-Maximum Values:**

DC SUPPLY-VOLTAGE RANGE, (V <sub>DD</sub> ) (Voltages referenced to V <sub>SS</sub> Terminal)	-0.5 to +20 V
INPUT VOLTAGE RANGE, ALL INPUTS	-0.5 to V <sub>DD</sub> +0.5 V
DC INPUT CURRENT, ANY ONE INPUT	±10 mA
POWER DISSIPATION PER PACKAGE (P <sub>D</sub> ):	
For T <sub>A</sub> = -40 to +60°C (PACKAGE TYPE E)	500 mW
For T <sub>A</sub> = +60 to +85°C (PACKAGE TYPE E)	Derate Linearly at 12 mW/°C to 200 mW
For T <sub>A</sub> = -55 to +100°C (PACKAGE TYPES D, F, K)	500 mW
For T <sub>A</sub> = +100 to +125°C (PACKAGE TYPES D, F, K)	Derate Linearly at 12 mW/°C to 200 mW
DEVICE DISSIPATION PER OUTPUT TRANSISTOR:	
For T <sub>A</sub> = FULL PACKAGE-TEMPERATURE RANGE (All Package Types)	100 mW
OPERATING-TEMPERATURE RANGE (T <sub>A</sub> ):	
PACKAGE TYPES D, F, K, H	-55 to +125°C
PACKAGE TYPE E	-40 to +85°C
STORAGE TEMPERATURE RANGE (T <sub>stg</sub> )	-65 to +150°C
LEAD TEMPERATURE (DURING SOLDERING):	
At distance 1/16 ± 1/32 inch (1.59 ± 0.79 mm) from case for 10 s max.	+265°C

# CD4543B Types

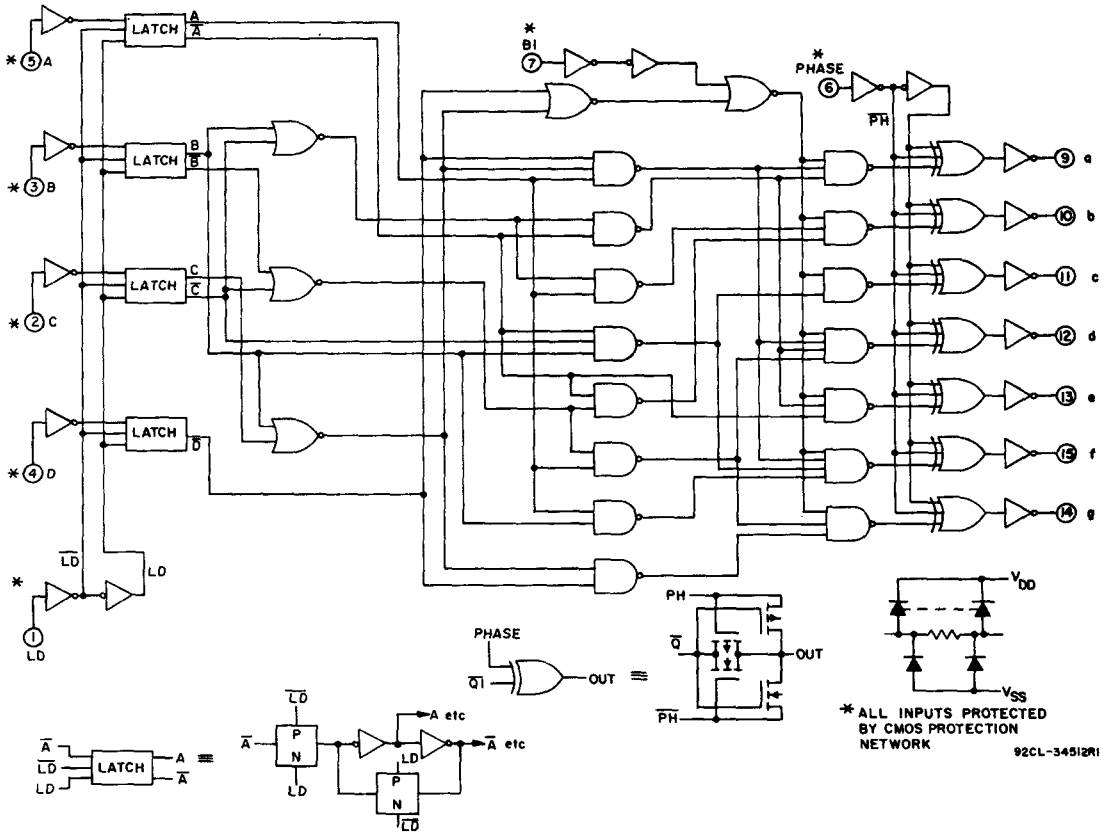

Fig. 1 - BCD-to-seven-segment latch/decoder/driver CD4543B logic circuit diagram.

## RECOMMENDED OPERATING CONDITIONS at $T_A=25^\circ\text{C}$ , Unless Otherwise Specified

For maximum reliability, nominal operating conditions should be selected so that operation is always within the following ranges:

CHARACTERISTIC	$V_{DD}$ (V)	LIMITS		UNITS
		MIN.	TYP.	
Supply-Voltage Range (For $T_A$ =Full Package-Temperature Range)	—	3	18	V
Latch Disable Pulse Width	5	250	125	ns
	10	100	50	
	15	80	40	
Minimum Data Setup Time	5	60	15	
	10	20	-5	
	15	10	-5	
Minimum Data Hold Time	5	25	-5	
	10	20	10	
	15	20	10	

# CD4543B Types

## STATIC ELECTRICAL CHARACTERISTICS

CHARACTERISTIC	CONDITIONS			LIMITS AT INDICATED TEMPERATURES (°C)							UNITS	
	V <sub>O</sub> (V)	V <sub>IN</sub> (V)	V <sub>DD</sub> (V)	Values at -55, +25, +125 Apply to D, F, K, H Packages				Values at -40, +25, +85 Apply to E Package				
				-55	-40	+85	+125	+25				
							Min.	Typ.	Max.			
Quiescent Device Current Max.	I <sub>DD</sub>	—	0, 5	5	5	5	150	150	—	0.04	5	μA
		—	0,10	10	10	10	300	300	—	0.04	10	
		—	0,15	15	20	20	600	600	—	0.04	20	
		—	0,20	20	100	100	3000	3000	—	0.08	100	
Output Low (Sink) Current Min.	I <sub>OL</sub>	0.4	0, 5	5	0.64	0.61	0.42	0.36	0.51	1	—	mA
		0.5	0,10	10	1.6	1.5	1.1	0.9	1.3	2.6	—	
		1.5	0,15	15	4.2	4	2.8	2.4	3.4	6.8	—	
Output High (Source) Current Min.	I <sub>OH</sub>	4.6	0, 5	5	-0.46	-0.44	-0.30	-0.26	-0.37	-0.75	—	mA
		2.5	0, 5	5	-1.6	-1.5	-1.1	-0.9	-1.3	-2.6	—	
		9.5	0,10	10	-0.98	-0.92	-0.68	-0.55	-0.8	-1.6	—	
		13.5	0,15	15	-3.33	-3.18	-2.2	-1.9	-2.7	-5.4	—	
Output Voltage: Low-Level Max.	V <sub>OL</sub>	—	0, 5	5	0.05			—	0	0.05	V	
		—	0,10	10	0.05			—	0	0.05		
		—	0,15	15	0.05			—	0	0.05		
Output Voltage: High-Level Min.	V <sub>OH</sub>	—	0, 5	5	4.95			4.95	5	—	V	
		—	0,10	10	9.95			9.95	10	—		
		—	0,15	15	14.95			14.95	15	—		
Input Low Voltage Max.	V <sub>IL</sub>	0.5,4,5	—	5	1.5			—	—	1.5	V	
		1, 9	—	10	3			—	—	3		
		1.5,13.5	—	15	4			—	—	4		
Input High Voltage Min.	V <sub>IH</sub>	0.5,4,5	—	5	3.5			3.5	—	—	V	
		1, 9	—	10	7			7	—	—		
		1.5,13.5	—	15	11			11	—	—		
Input Current Max.	I <sub>IN</sub>	—	0,18	18	±0.1	±0.1	±1	±1	—	±10 <sup>-5</sup>	±0.1	μA

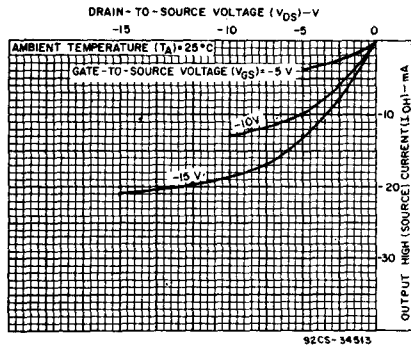

Fig. 2 - Typical output high (source) current characteristics.

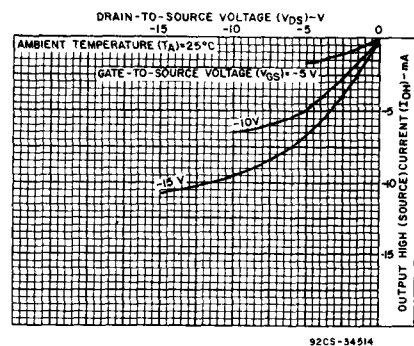

Fig. 3 - Minimum output high (source) current characteristics.

# CD4543B Types

DYNAMIC ELECTRICAL CHARACTERISTICS at  $T_A=25^\circ\text{C}$ ;  $C_L=50\text{ pF}$ , Input  $t_r, t_f=20\text{ ns}$ ,  $R_L=200\text{ k}\Omega$

CHARACTERISTIC	TEST CONDITIONS $V_{DD}$ (V)	LIMITS All Packages			UNITS	
		MIN.	TYP.	MAX.		
Propagation Delay Time	$t_{PHL}$	5	—	600	ns	
		10	—	200		
		15	—	150		
	$t_{PLH}$	5	—	500		
		10	—	200		
		15	—	150		
Transition Time	$t_{THL}$	5	—	180		
		10	—	90		
		15	—	65		
	$t_{TLH}$	5	—	180		
		10	—	90		
		15	—	65		
Latch Disable Pulse Width	$t_{WH}$	5	250	125	—	
		10	100	50	—	
		15	80	40	—	
Address Setup Time	$t_{SU}$	5	60	15	—	
		10	20	-5	—	
		15	10	-5	—	
Address Hold Time	$t_H$	5	25	-5	—	
		10	20	10	—	
		15	20	10	—	
Input Capacitance	$C_{IN}$	Any Input	—	5	7.5	pF

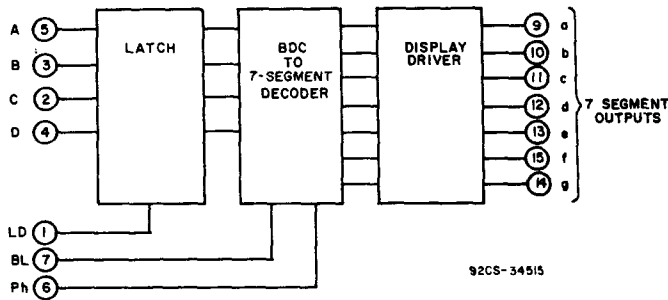

Fig. 4 - BCD-to-seven-segment latch/decoder/driver functional diagram.

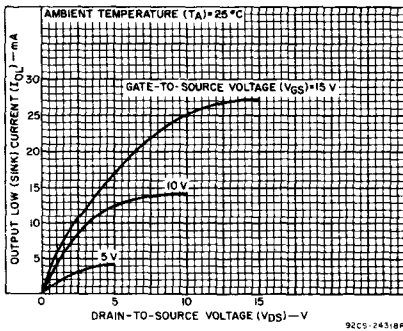

Fig. 5 - Typical output low (sink) current characteristics.

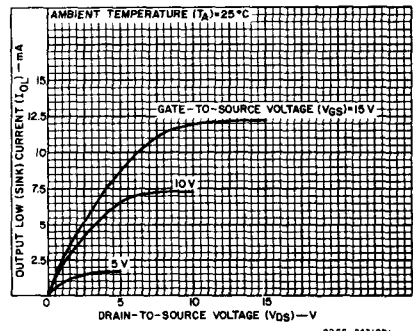

Fig. 6 - Minimum output low (sink) current characteristics.

# CD4543B Types

TRUTH TABLE FOR CD4543B

INPUT CODE							OUTPUT STATE							DISPLAY CHARACTER
LD	BI	Ph*	D	C	B	A	a	b	c	d	e	f	g	
X	1	0	X	X	X	X	0	0	0	0	0	0	0	
1	0	0	0	0	0	0	1	1	1	1	1	1	0	
1	0	0	0	0	0	1	0	1	1	0	0	0	0	
1	0	0	0	0	1	0	1	1	0	1	1	0	1	
1	0	0	0	0	1	1	1	1	1	1	0	0	1	
1	0	0	0	1	0	0	0	1	1	0	0	1	1	
1	0	0	0	1	0	1	1	0	1	1	0	1	1	
1	0	0	0	1	1	1	1	1	1	0	0	0	0	
1	0	0	1	0	0	0	1	1	1	1	1	1	1	
1	0	0	1	0	0	1	1	1	1	1	0	1	1	
1	0	0	1	0	1	0	0	0	0	0	0	0	0	
1	0	0	1	0	1	1	0	0	0	0	0	0	0	
1	0	0	1	1	0	0	0	0	0	0	0	0	0	
1	0	0	1	1	0	1	0	0	0	0	0	0	0	
1	0	0	1	1	1	0	0	0	0	0	0	0	0	
1	0	0	1	1	1	1	0	0	0	0	0	0	0	
0	0	0	X	X	X	X	**							**
†	†	1	†				Inverse of Output Combinations Above							Display as above

X=Don't care.  
 †=Above combinations.  
 \*=For liquid-crystal readouts, apply a square wave to Ph.  
 For common cathode LED readouts, select Ph=0.  
 For common anode LED readouts, select Ph=1.  
 \*\*=Depends upon the BCD code previously applied when LD=1.

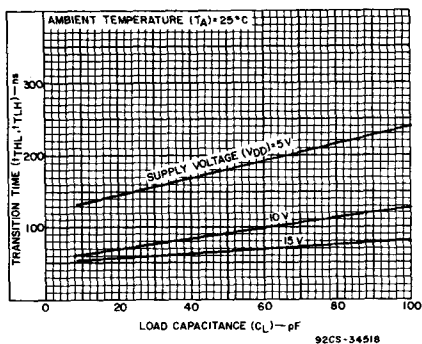

Fig. 7 - Typical transition time as a function of load capacitance.

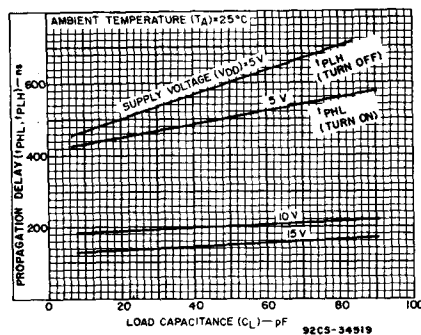

Fig. 8 - Typical propagation delay time as a function of load capacitance.

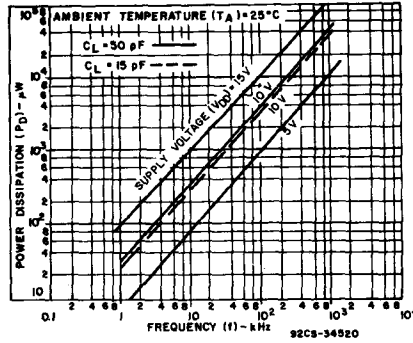

Fig. 9 - Typical dynamic power dissipation as a function of frequency.

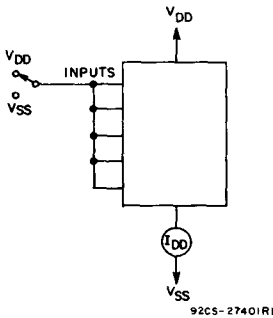

Fig. 10 - Quiescent device current test circuit.

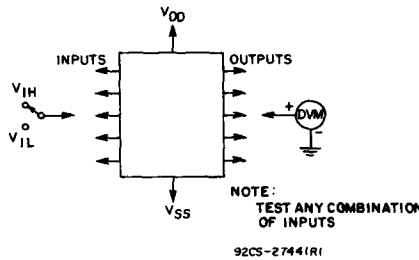

Fig. 11 - Input voltage test circuit.

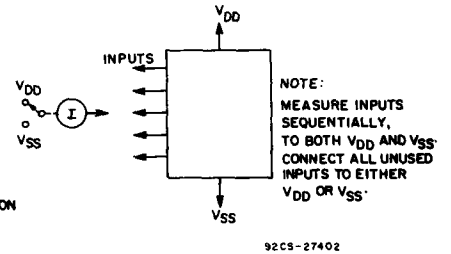
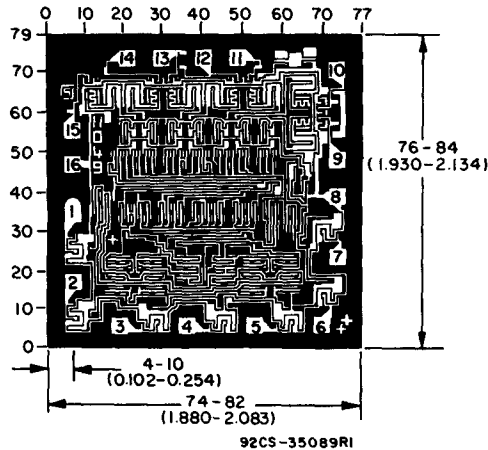

Fig. 12 - Input current test circuit.



Dimensions and pad layout for CD4543BH.

Dimensions in parentheses are in millimeters and are derived from the basic inch dimensions as indicated. Grid graduations are in mils ( $10^{-3}$  inch).

The photographs and dimensions of each CMOS chip represent a chip when it is part of the wafer. When the wafer is separated into individual chips, the angle of cleavage may vary with respect to the chip face for different chips. The actual dimensions of the isolated chip, therefore, may differ slightly from the nominal dimensions shown. The user should consider a tolerance of -3 mils to +16 mils applicable to the nominal dimensions shown.