

CDBN120-HF Thru. CDBN1100-HF

Forward current: 1.0A

Reverse voltage: 20 to 100V

RoHS Device
Halogen Free



Features

- Low power loss, High efficiency.
- High current capability, low VF
- Plastic package has UL 94V-0.

Mechanical Data

- Case: Packed with FRP substrate and epoxy underfilled.
- Terminals: Pure Tin plated (Lead-Free), solderable per MIL-STD-750, method 2026.
- Polarity: Laser cathode band marking.
- Weight: 0.012 grams(approx).

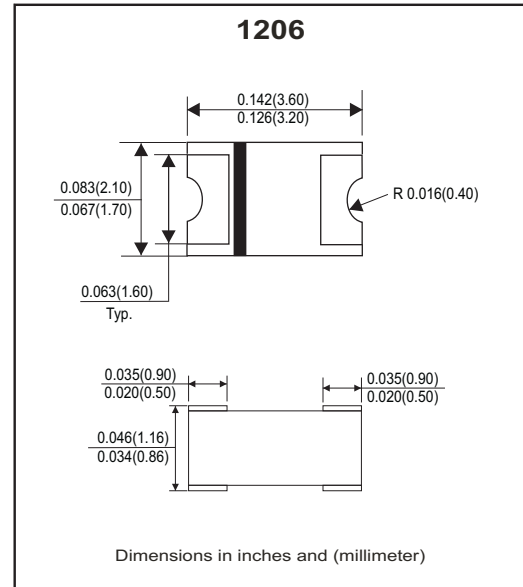

Circuit diagram



Maximum Ratings (At Ta=25°C, unless otherwise noted)

Parameter	Symbol	CDBN120-HF	CDBN140-HF	CDBN160-HF	CDBN1100-HF	Unit
Non-repetitive peak reverse voltage	V _{RM}	20	40	60	100	V
Average forward current	I _{F(AV)}	1				A
Peak forward surge current @8.3ms single half sine-wave	I _{FSM}	20				A
Operating junction temperature range	T _J	-55 to +125		-55 to +150		°C
Storage temperature	T _{STG}	-55 ~ +150				°C

Electrical Characteristics (At Ta=25°C, unless otherwise noted)

Parameter	Conditions	Type	Symbol	Min.	Typ.	Max.	Unit
Forward voltage (Note1)	I _F =0.1A I _F =0.5A I _F =1.0A	CDBN120-HF CDBN140-HF	V _F	-	0.32	-	V
				-	0.40	-	
				-	0.46	0.50	
	I _F =0.1A I _F =0.5A I _F =1.0A	CDBN160-HF		-	0.35	-	
				-	0.48	-	
				-	0.62	0.70	
	I _F =0.1A I _F =0.5A I _F =1.0A	CDBN1100-HF		-	0.45	-	
				-	0.66	-	
				-	0.76	0.85	
Reverse peak reverse current (Note1)	V _R =Max.V _{RRM} , Ta=25°C		I _{RRM}	-	0.015	0.2	mA
Junction capacitance	V _R =4V, f=1.0MHz		C _j	-	110	-	pF
Thermal resistance	Junction to ambient (Note 2)		R _{θJA}	-	88	-	°C/W
	Junction to lead (Note 2)		R _{θJL}	-	28	-	°C/W

Notes: (1) Pulse test width pw=300usec, 1% duty cycle.

(2) Mounted on P.C. board with 0.2*0.2"(5.0*5.0mm) copper pad areas.

Company reserves the right to improve product design , functions and reliability without notice.

REV:B

RATING AND CHARACTERISTIC CURVES (CDBN120-HF Thru. CDBN1100-HF)

Fig.1 - Typical Forward Current Derating Curve

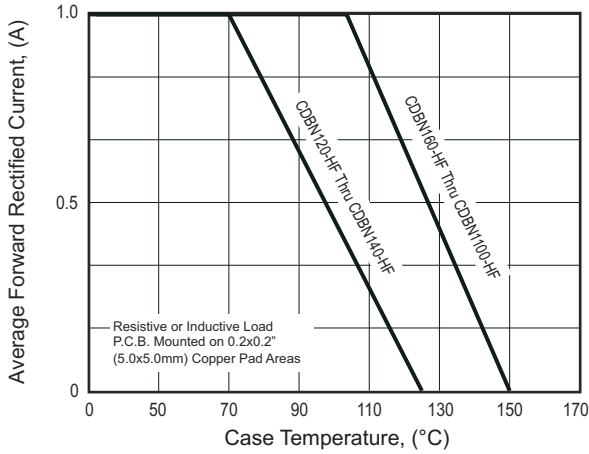

Fig.2 - Maximum Non-Repetitive Peak Forward Surge Current

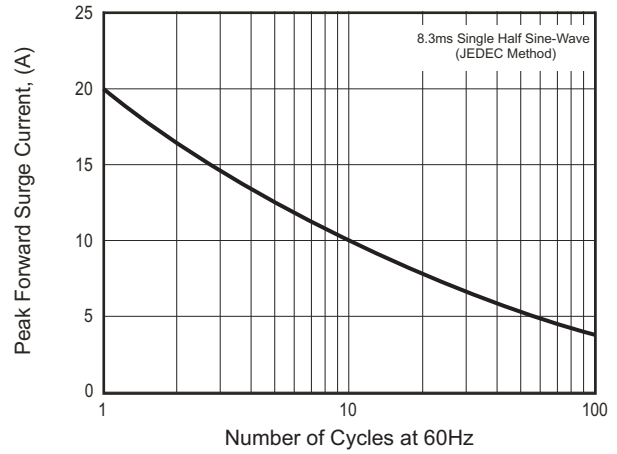

Fig.3 - Typical Instantaneous Forward Characteristics

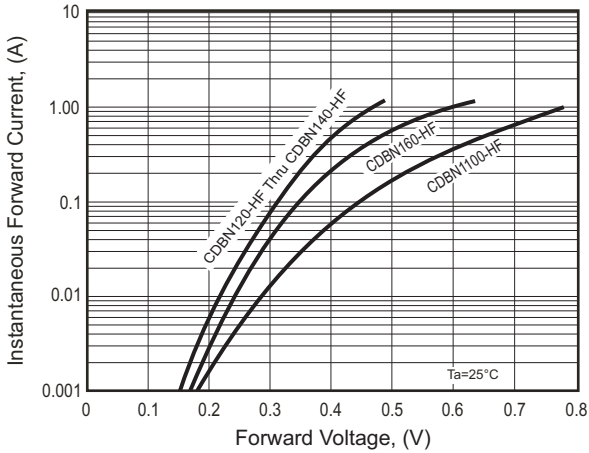

Fig.4 - Typical Reverse Characteristics

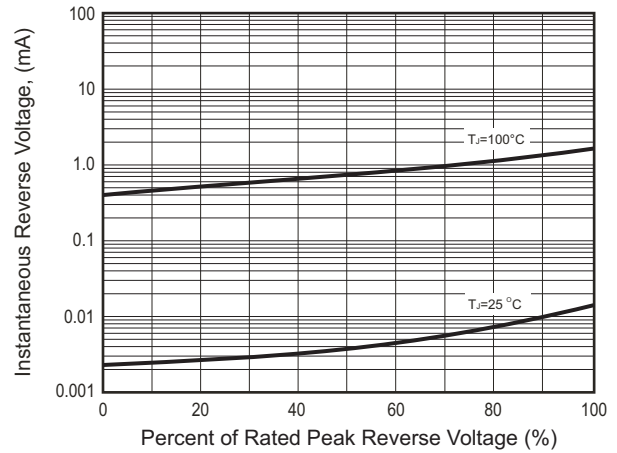
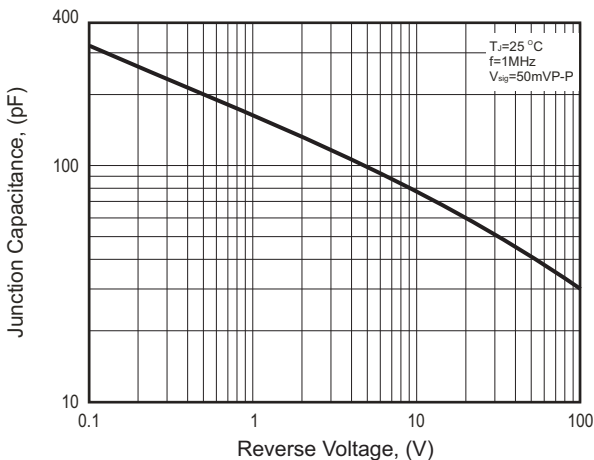
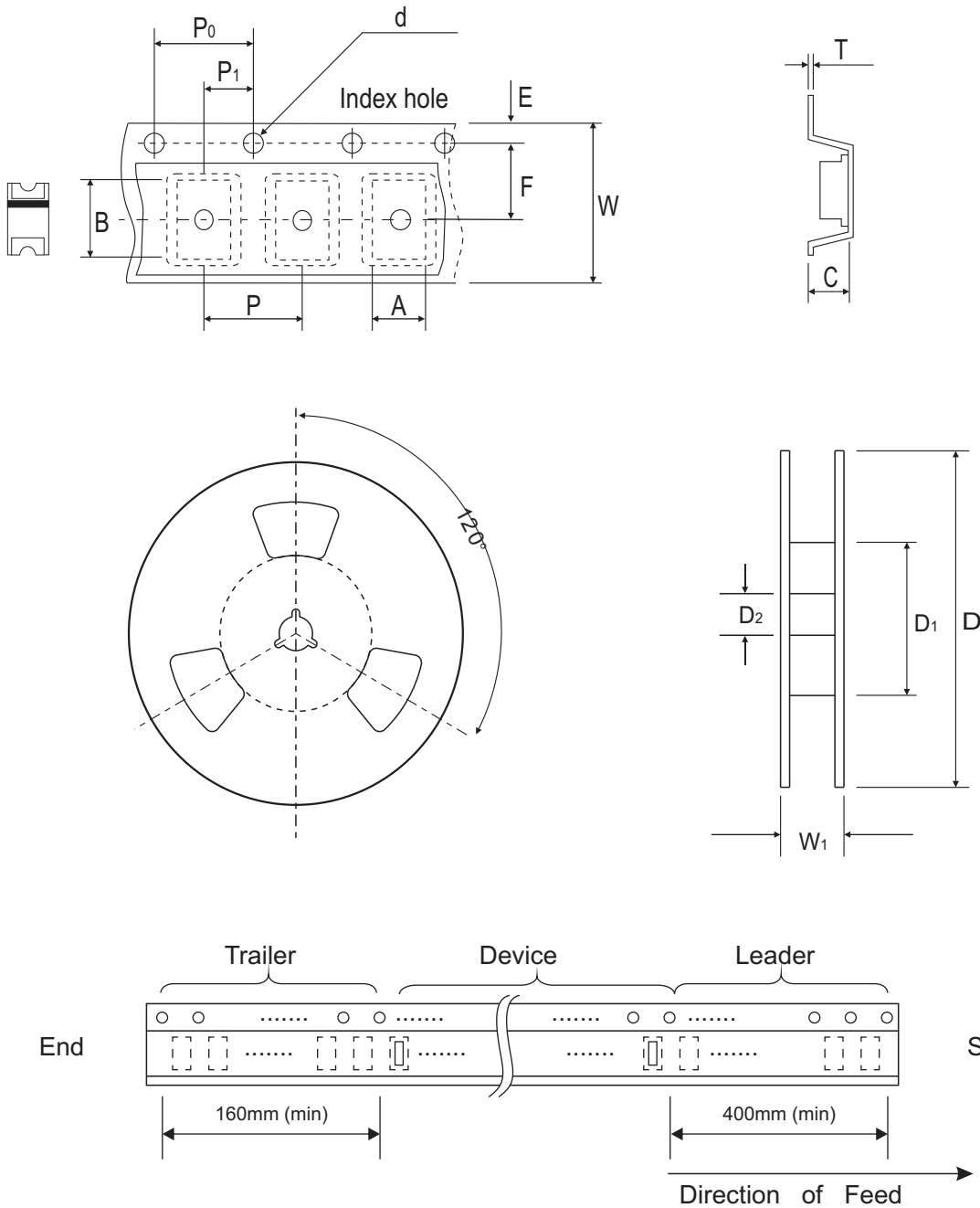

Fig.5 - Typical Junction Capacitance



Reel Taping Specification



1206	SYMBOL	A	B	C	d	D	D ₁	D ₂
	(mm)	2.20 ± 0.10	3.65 ± 0.10	1.28 ± 0.10	1.50 ± 0.10	178.00 ± 2.00	50.00 MIN.	13.00 ± 0.50
	(inch)	0.087 ± 0.004	0.144 ± 0.004	0.050 ± 0.004	0.059 ± 0.004	7.008 ± 0.079	1.969 MIN.	0.512 ± 0.020

1206	SYMBOL	E	F	P	P ₀	P ₁	W	W ₁
	(mm)	1.75 ± 0.10	5.50 ± 0.05	4.00 ± 0.10	4.00 ± 0.10	2.00 ± 0.10	12.00 ± 0.30	18.70 MAX.
	(inch)	0.069 ± 0.004	0.217 ± 0.002	0.157 ± 0.004	0.157 ± 0.004	0.079 ± 0.004	0.472 ± 0.012	0.736 MAX.

Marking Code

Part Number	Marking Code
CDBN120-HF	A2.
CDBN140-HF	A4.
CDBN160-HF	A6.
CDBN1100-HF	A10.

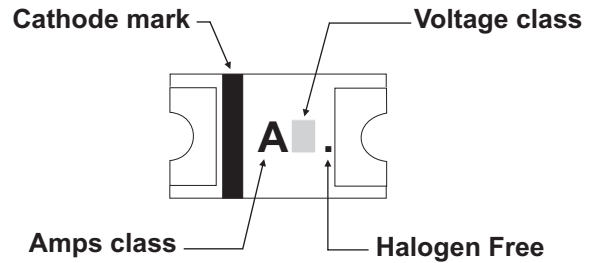

Suggested PAD Layout

SIZE	1206	
	(mm)	(inch)
A	1.50 MIN.	0.059MIN.
B	1.00	0.039
C	2.00MAX.	0.079MAX.
D	4.00REF.	0.157 REF.

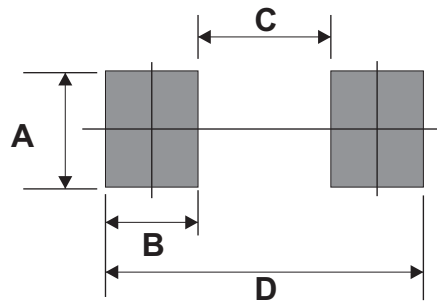

Standard Packaging

Case Type	REEL PACK	
	REEL (pcs)	Reel Size (inch)
1206	3,000	7