

January 1991

CMOS Parallel Interface

Features

- 24 Individual Programmed I/O Pins
- MOTEL Circuit for Bus Compatibility With Many Microprocessors
- Multiplexed Bus Compatible With CDP6805E2 and Competitive Microprocessors
- Data Direction Registers for Ports A, B and C
- Reset Input to Clear Interrupts and Initialize Internal Registers
- Four Port C I/O Pins May Be Used as Control Lines
 - ▶ Four Interrupt Inputs
 - ▶ Input Byte Latch
 - ▶ Output Pulse
 - ▶ Handshake Activity
- 15 Registers Addressed as Memory Locations
- Handshake Control Logic for Input and Output Peripheral Operation
- Interrupt Output Pin
- 3V to 5.5V Operating V_{DD}

Description

The CDP6823 CMOS parallel interface (CPI) provides a universal means of interfacing external signals with the CDP6805E2 CMOS microprocessor and other multiplexed bus microprocessors. The unique MOTEL circuit on chip allows direct interfacing to most industry CMOS microprocessors, as well as many NMOS MPU's.

The CDP6823 CPI includes three bidirectional 8-bit ports or 24 I/O pins. Each I/O line may be separately established as an input or an output under program control via data direction registers associated with each port. Using the bit change and test instructions of the CDP6805E2, each individual I/O pin can be separately accessed. All port registers are read/write bytes to accommodate read-modify-write instructions.

The CDP6823 is supplied in a 40 lead hermetic dual-in-line sidebraced ceramic package (D suffix), in a 40 lead dual-in-line plastic package (E suffix) and in a 44 lead plastic chip carrier package (N suffix).

The CDP6823 is equivalent to and is a direct replacement for the industry type MC146823.

Block Diagram

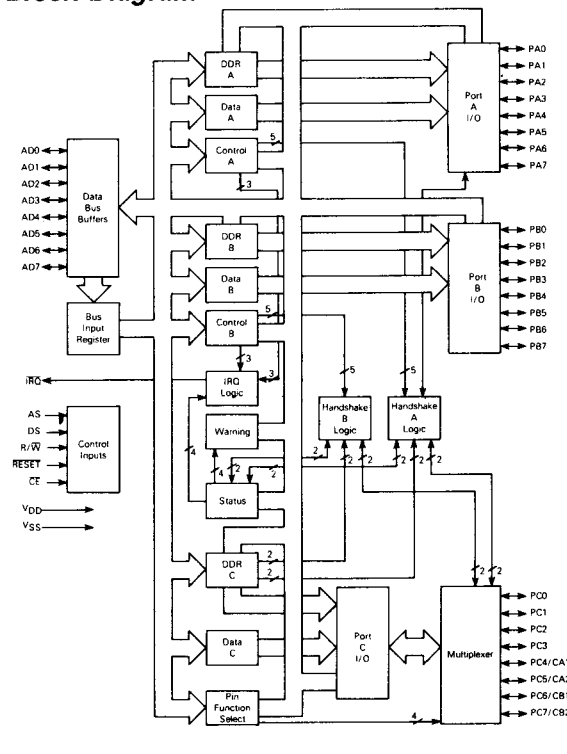

Pinouts

PACKAGE TYPES D AND E

TOP VIEW

PC2	1	40	V _{DD}
PC1	2	39	PC3
PC0	3	38	PC4/CA1
PA0	4	37	PC5/CA2
PA1	5	36	PC6/CB
PA2	6	35	PC7/CB2
PA3	7	34	PB0
PA4	8	33	PB1
PA5	9	32	PB2
PA6	10	31	PB3
PA7	11	30	PB4
AD0	12	29	PB5
AD1	13	28	PB6
AD2	14	27	PB7
AD3	15	26	IRG
AD4	16	25	RESET
AD5	17	24	DS
AD6	18	23	R/W
AD7	19	22	AS
V _{SS}	20	21	CE

PACKAGE TYPE N

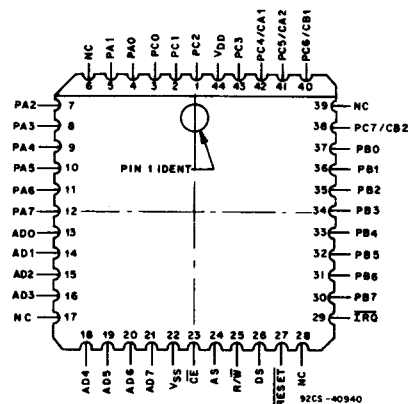

5
8-BIT BUS PERIPHERALS

MAXIMUM RATINGS (Voltages reference to V_{SS})

Ratings	Symbol	Value	Unit
Supply Voltage	V _{DD}	-0.3 to +8	V
All Input Voltages	V _{in}	V _{SS} -0.5 to V _{DD} +0.5	V
Current Drain per Pin Excluding V _{DD} and V _{SS}	I	10	mA
Operating Temperature Range	T _A	-40 to +85	°C
Storage Temperature Range	T _{stg}	-55 to +150	°C

This device contains circuitry to protect the inputs against damage due to high static voltages or electric fields; however, it is advised that normal precautions be taken to avoid application of any voltage higher than maximum rated voltages to this high-impedance circuit. For proper operation it is recommended that V_{in} and V_{out} be constrained to the range V_{SS} ≤ (V_{in} or V_{out}) ≤ V_{DD}. Leakage currents are reduced and reliability of operation is enhanced if unused inputs are tied to an appropriate logic voltage level (e.g., either V_{SS} or V_{DD}).

THERMAL CHARACTERISTICS

Characteristics	Symbol	Value	Unit
Thermal Resistance Ceramic Dual-In-Line Plastic Dual-In-Line Plastic Chip-Carrier	θ _{JA}	50 100 70	°C/W

DC ELECTRICAL CHARACTERISTICS (V_{DD}=5 Vdc ± 10%, V_{SS}=0 Vdc, T_A=0°C to 70°C, unless otherwise noted)

Parameter	Symbol	Min	Max	Unit
Output Voltage (I _{Load} ≤ 10 μA)	V _{OL} V _{OH}	- V _{DD} -0.1	0.1 -	V V
Output High Voltage (I _{Load} = -1.6 mA) AD0-AD7 (I _{Load} = -0.2 mA) PA0-PA7, PC0-PC7 (I _{Load} = -0.36 mA) PB0-PB7	V _{OH} V _{OH} V _{OH}	4.1 4.1 4.1	V _{DD} V _{DD} V _{DD}	V
Output Low Voltage (I _{Load} = 1.6 mA) AD0-AD7, PB0-PB7 (I _{Load} = 0.8 mA) PA0-PA7, PC0-PC7 (I _{Load} = 1 mA) \overline{IRQ}	V _{OL} V _{OL} V _{OL}	V _{SS} V _{SS} V _{SS}	0.4 0.4 0.4	V
Input High Voltage, AD0-AD7, AS, DS, R/ \overline{W} , \overline{CE} , PA0-PA7, PB0-PB7, PC0-PC7 RESET	V _{IH} V _{IH}	V _{DD} -2.0 V _{DD} -0.8	V _{DD} V _{DD}	V
Input Low Voltage (All Inputs)	V _{IL}	V _{SS}	0.8	V
Quiescent Current - No dc Loads (All Ports Programmed as Inputs, All Inputs = V _{DD} - 0.2 V)	I _{DD}	-	160	μA
Total Supply Current (All Ports Programmed as Inputs, CE = V _{IL} , t _{cyc} = 1 μs)	I _{DD}	-	3	mA
Input Current, \overline{CE} , AS, R/ \overline{W} , DS, RESET	I _{in}	-	±1	μA
Hi-Z State Leakage, AD0-AD7, PA0-PA7, PB0-PB7, PC0-PC7	I _{TSL}	-	±10	μA

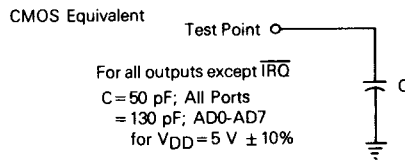
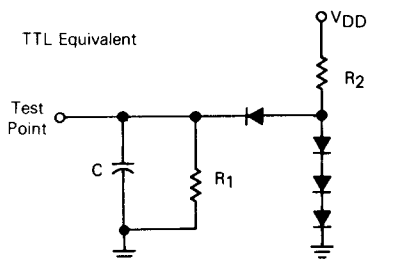

Pin	R1	R2	C
AD0-AD7	2.55k	2k	130 pF
PA0-PA7, PC0-PC7	2.2k	4.32k	50 pF
PB0-PB7	11.5k	2.1k	50 pF

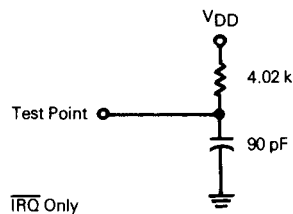

Fig. 2 - Equivalent test loads.