

SMD Power Inductor

CDPQ2417



New Recommended Type

Description

- Ferrite core construction.
- Magnetically shielded.
- LxWxH:27.5x26.5x18.0mm Max.
- Product weight: 30g(Ref.)
- Moisture Sensitivity Level: 1



Environmental Data

- Operating temperature range: -40°C~+105°C (including coil's self temperature rise)
- Storage temperature range: -40°C~+105°C

Packaging

- Pallet packaging. 40pcs per pallet, 200pcs per package.

Applications

- High Current Inductor for DC/DC converters in distributed power systems and PV inverters etc.

Dimension - [mm]

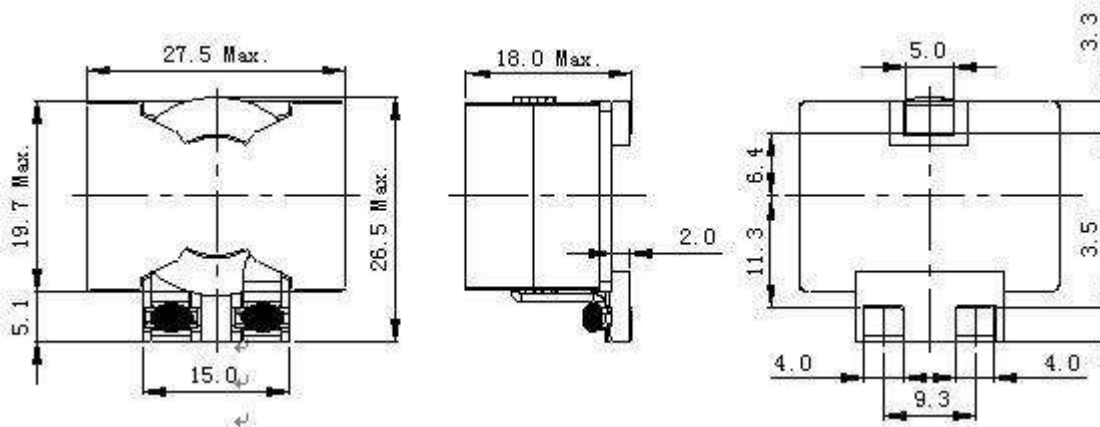

Recommended Land pattern - [mm]

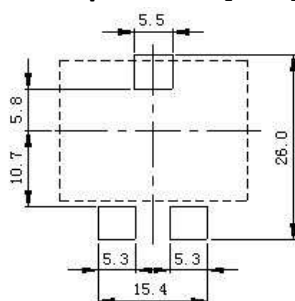

Wire Connection

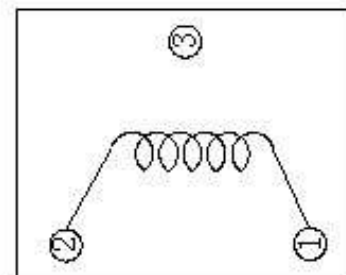

Note: This specification is subject to change without notice. Please contact your nearest sales office for updated information when placing an order.

SMD Power Inductor

CDPQ2417



Electrical Characteristics

Part Number	Inductance [Within] (μ H) ※1	D.C.R. at 20°C max(typ) (m Ω)	Saturation Current at 20°C(A) ※2	Temperature Rise Current (A) ※3
CDPQ2417NP-2R2MB	2.20 \pm 20%	2.05 (1.80)	100	30.00
CDPQ2417NP-3R3MB	3.30 \pm 20%	2.05 (1.80)	72.00	30.00
CDPQ2417NP-4R7MB	4.70 \pm 20%	2.05 (1.80)	52.00	30.00
CDPQ2417NP-6R8MB	6.80 \pm 20%	2.05 (1.80)	35.00	30.00
CDPQ2417NP-100MB	10.00 \pm 20%	2.05 (1.80)	23.00	30.00
CDPQ2417NP-150MB	15.00 \pm 20%	2.05 (1.80)	15.20	30.00

※1 Measuring condition at 100kHz 0.1V.

※2 Saturation current: The actual value of D.C. current when the inductance decreases to 80% of it's initial value.

※3 Temperature rise current: The actual value of D.C. current when the temperature rise is $\Delta t=40^{\circ}\text{C}$ ($T_a=20^{\circ}\text{C}$).

Solder Reflow Condition

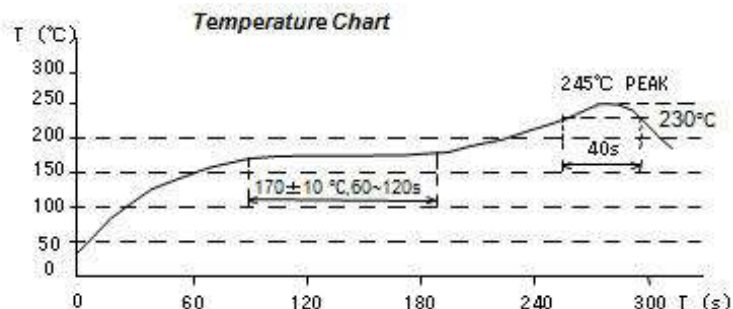
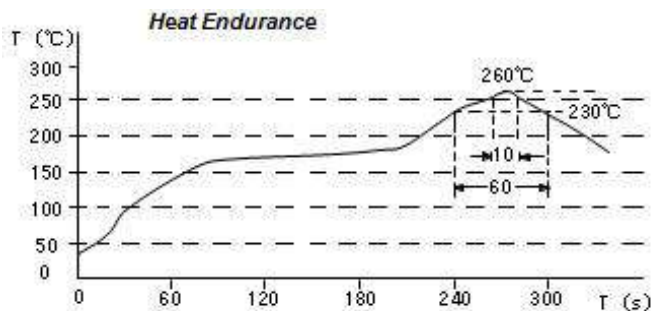

SMD Power Inductor

CDPQ2417



Saturation Current & Temperature Rise Graph

— L (20°C) — ΔT

1. CDPQ2417NP-2R2MB

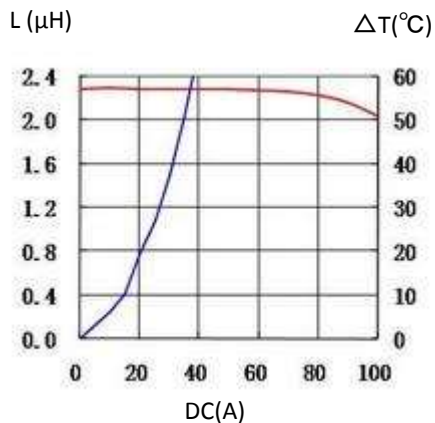

2. CDPQ2417NP-3R3MB

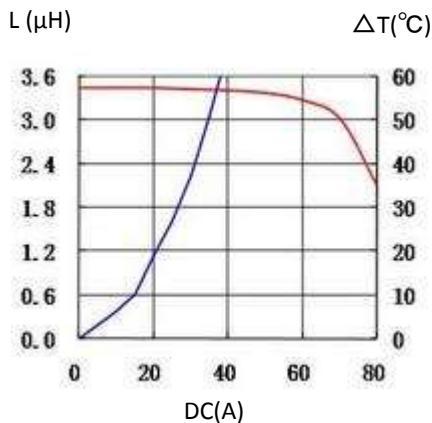

3. CDPQ2417NP-4R7MB

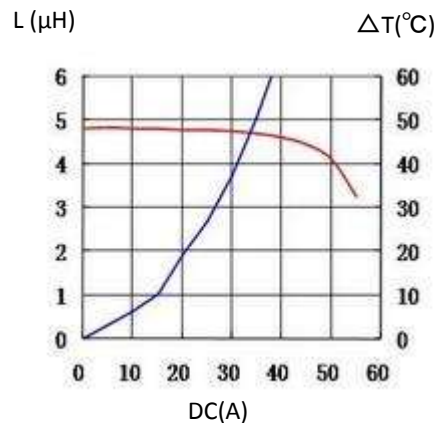

4. CDPQ2417NP-6R8MB

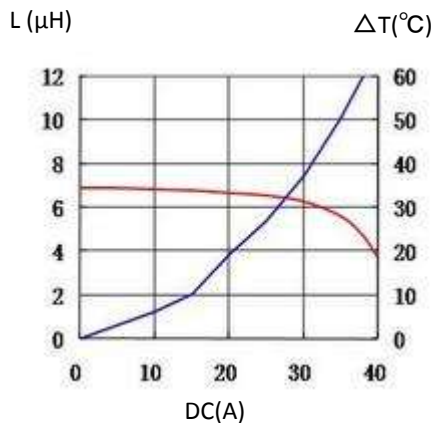

5. CDPQ2417NP-100MB

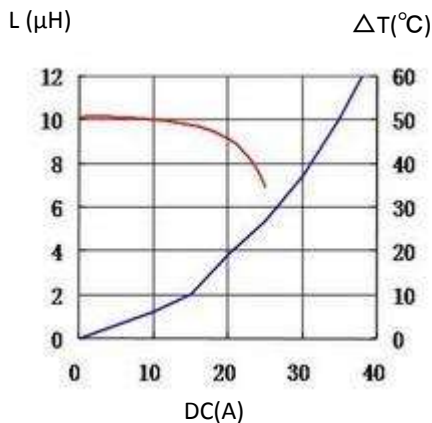

6. CDPQ2417NP-150MB

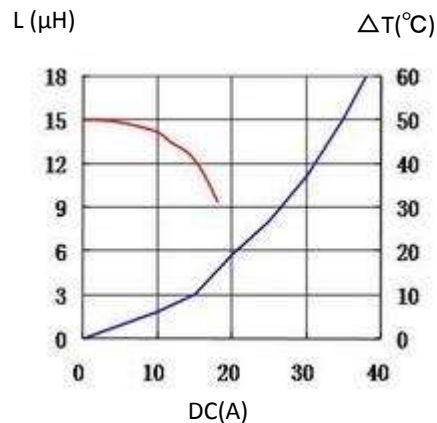

For sales office information, please [click here](#) to visit our website.