

## CDSN4148

### High Speed

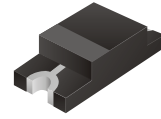

### Features

- Designed for mounting on small surface.
- High speed switching.
- High mounting capability, strong surge withstand, high reliability.

### Mechanical data

- Case: 1206(3216) standard package, molded plastic.
- Terminals: Solder plated, solderable per MIL-STD-750, method 2026.
- Polarity: Indicated by cathode band.
- Mounting position: Any.
- Weight: 0.0085 gram. (approximately)

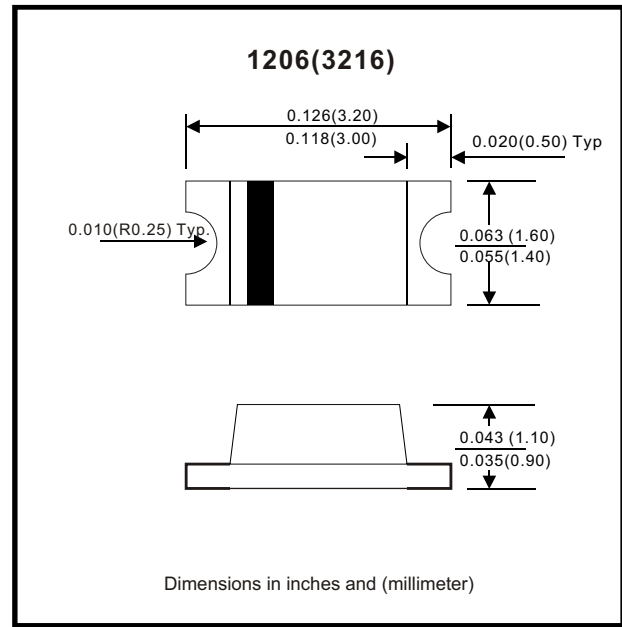

### Maximum Rating ( at TA = 25°C unless otherwise noted )

Parameter	Conditions	Symbol	Min	Typ	Max	Unit
Repetitive peak reverse voltage		V <sub>RRM</sub>			100	V
Reverse voltage		V <sub>R</sub>			75	V
Average forward current		I <sub>o</sub>			150	mA
Forward current , surge peak	T <sub>p</sub> = 1us T <sub>p</sub> = 1s	I <sub>FSM</sub>		4 1		A
Power Dissipation		P <sub>D</sub>			350	mW
Storage temperature		T <sub>STG</sub>	-55		+175	°C
Junction temperature		T <sub>j</sub>	-55		+175	°C

### Electrical Characteristics ( at TA = 25°C unless otherwise noted )

Parameter	Conditions	Symbol	Min	Typ	Max	Unit
Forward voltage	I <sub>F</sub> = 50 mADC	V <sub>F</sub>			1.0	V
Reverse current	V <sub>R</sub> = 20 V V <sub>R</sub> = 75 V	I <sub>R</sub>			25 2.5	nA uA
Capacitance between terminals	f = 1MHz, and 0 VDC reverse voltage	C <sub>T</sub>			3	pF
Reverse recovery time	V <sub>R</sub> = 6V, I <sub>F</sub> = 10 mA, R <sub>L</sub> = 50 ohms	T <sub>rr</sub>			4	nS

## RATING AND CHARACTERISTIC CURVES (CDSN4148)

Fig. 1 - Forward characteristics

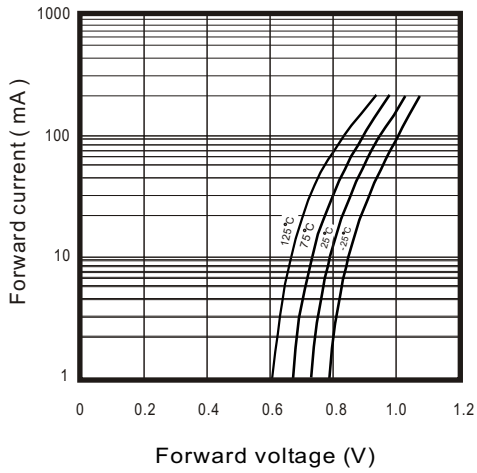

Fig. 2 - Reverse characteristics

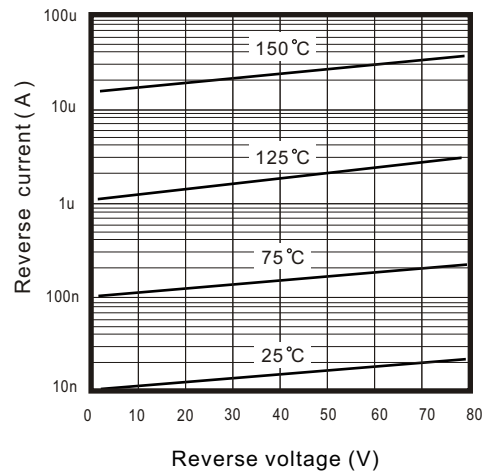

Fig. 3 - Capacitance between terminals characteristics

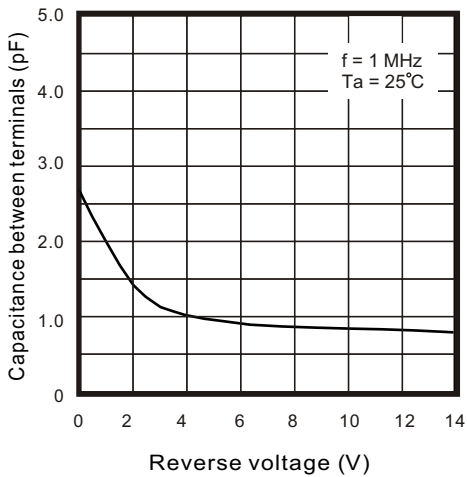

Fig. 4 - Current derating curve

