

CDX-CA850/CA850X/CA860X

SERVICE MANUAL

Ver 1.0 2001. 02

US Model
Canadian Model
CDX-CA850X/CA860X

AEP Model
UK Model
CDX-CA850



Photo: CDX-CA850X

- The tuner and CD sections have no adjustments.

AUDIO POWER SPECIFICATIONS (US Model)

POWER OUTPUT AND TOTAL HARMONIC DISTORTION
23.2 watts per channel minimum continuous average power into
4 ohms, 4 channels driven from 20 Hz to 20 kHz with no more
than 5% total harmonic distortion.

CD player section

Signal-to-noise ratio 90 dB
Frequency response 10 – 20,000 Hz
Wow and flutter Below measurable limit
Laser Diode Properties (US, Canadian Model)
Material GaAlAs
Wavelength 780 nm
Emission Duration Continuous
Laser output power Less than 44.6 μ W*

* This output is the value measured at a distance
of 200 mm from the objective lens surface on the
Optical Pick-up Block.

Tuner section

FM

Tuning range 87.5 – 107.9 MHz (US, Canadian model)
87.5 – 108.0 MHz (AEP, UK model)
Antenna terminal External Antenna connector
Intermediate frequency 10.7 MHz/450 kHz
Usable sensitivity 8 dBf
Selectivity 75 dB at 400 kHz
Signal-to-noise ratio 66 dB (stereo),
72 dB (mono)
Harmonic distortion at 1 kHz
0.6% (stereo),
0.3% (mono)
Separation 35 dB at 1 kHz
Frequency response 30 – 15,000 Hz

AM (US, Canadian model)

Tuning range 530 – 1,710 kHz (US, Canadian model)
Antenna terminal External Antenna connector
Intermediate frequency 10.7 MHz/450 kHz
Sensitivity 30 μ V

MW/LW (AEP, UK model)

Tuning range MW: 531 – 1,602 kHz
LW: 153 – 279 kHz
Aerial terminal External Aerial connector
Intermediate frequency 10.7 MHz/450 kHz
Sensitivity MW: 30 μ V
LW: 40 μ V

9-870-291-11
2001B0400-1
© 2001. 2

Sony Corporation
Audio Entertainment Group
General Engineering Dept.

Model Name Using Similar Mechanism	CDX-C5000R
CD Drive Mechanism Type	MG-383Z-121//Q
Optical Pick-up Name	KSS-720A

SPECIFICATIONS

Power amplifier section

Outputs Speaker outputs
(sure seal connectors)
Speaker impedance 4 – 8 ohms
Maximum power output 52 W \times 4 (at 4 ohms)

General

Outputs Audio outputs (front/rear)
Subwoofer output (mono)
Power Antenna relay control lead
Power amplifier control lead
Telephone ATT control lead
Illumination control lead
Bus control input connector
Bus audio input connector
Remote controller input connector
Antenna input connector
Tone controls Bass \pm 10 dB at 62 Hz (US, Canadian model)
Bass \pm 8 dB at 100 Hz (AEP, UK model)
Treble \pm 10 dB at 16 kHz (US, Canadian model)
Treble \pm 8 dB at 10 kHz (AEP, UK model)
Loudness +8 dB at 100 Hz
+2 dB at 10 kHz
Power requirements 12 V DC car battery
(negative ground)

– Continued on next page –

FM/MW/LW COMPACT DISC PLAYER
CDX-CA850

FM/AM COMPACT DISC PLAYER
CDX-CA850X/CA860X

SONY®

CDX-CA850/CA850X/CA860X

Dimensions	Approx. 178 × 50 × 177 mm (7 1/8 × 2 × 7 in.) (w/h/d)
Mounting dimensions	Approx. 182 × 53 × 162 mm (7 1/4 × 2 1/8 × 6 1/2 in.) (w/h/d)
Mass	Approx. 1.3 kg (2 lb. 10 oz.)
Supplied accessories	Parts for installation and connections (1 set) Front panel case (1) Rotary commander RM-X5S Card remote commander RM-X112 (CDX-CA850X/CA860X) RM-X113 (CDX-CA850)

Note

This unit cannot be connected to a digital preamplifier or an equalizer.

Design and specifications are subject to change without notice.

SERVICE NOTES

• US, Canadian model

CAUTION

Use of controls or adjustments or performance of procedures other than those specified herein may result in hazardous radiation exposure.

If the optical pick-up block is defective, please replace the whole optical pick-up block.

Never turn the semi-fixed resistor located at the side of optical pick-up block.

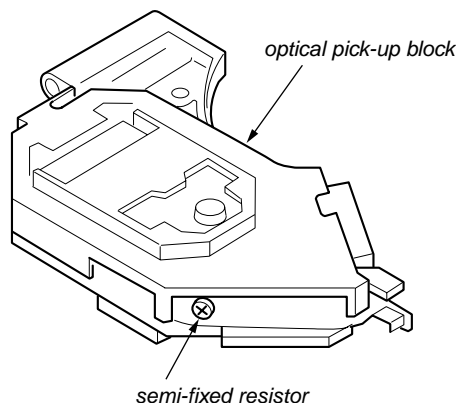

NOTES ON HANDLING THE OPTICAL PICK-UP BLOCK OR BASE UNIT

The laser diode in the optical pick-up block may suffer electrostatic breakdown because of the potential difference generated by the charged electrostatic load, etc. on clothing and the human body.

During repair, pay attention to electrostatic breakdown and also use the procedure in the printed matter which is included in the repair parts.

The flexible board is easily damaged and should be handled with care.

SAFETY-RELATED COMPONENT WARNING!!

COMPONENTS IDENTIFIED BY MARK \triangle OR DOTTED LINE WITH MARK \triangle ON THE SCHEMATIC DIAGRAMS AND IN THE PARTS LIST ARE CRITICAL TO SAFE OPERATION. REPLACE THESE COMPONENTS WITH SONY PARTS WHOSE PART NUMBERS APPEAR AS SHOWN IN THIS MANUAL OR IN SUPPLEMENTS PUBLISHED BY SONY.

• AEP, UK model

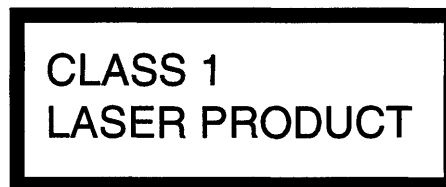

This label is located on the bottom of the chassis.

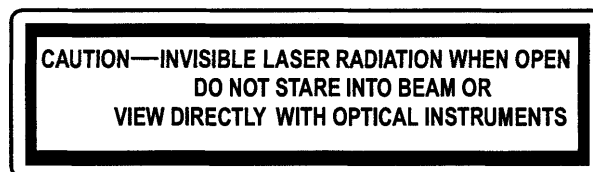

This label is located on the drive unit's internal chassis.

When replacing the chassis (T.U) of mechanism deck which have the "CAUTION LABEL" attached, please be sure to put a new CAUTION LABEL (3-223-913-11) to the chassis (T.U).

NOTES ON LASER DIODE EMISSION CHECK

The laser beam on this model is concentrated so as to be focused on the disc reflective surface by the objective lens in the optical pick-up block. Therefore, when checking the laser diode emission, observe from more than 30 cm away from the objective lens.

Notes on Chip Component Replacement

- Never reuse a disconnected chip component.
- Notice that the minus side of a tantalum capacitor may be damaged by heat.

ATTENTION AU COMPOSANT AYANT RAPPORT À LA SÉCURITÉ!!

LES COMPOSANTS IDENTIFIÉS PAR UNE MARQUE \triangle SUR LES DIAGRAMMES SCHÉMATIQUES ET LA LISTE DES PIÈCES SONT CRITIQUES POUR LA SÉCURITÉ DE FONCTIONNEMENT. NE REMPLACER CES COMPOSANTS QUE PAR DES PIÈCES SONY DONT LES NUMÉROS SONT DONNÉS DANS CE MANUEL OU DANS LES SUPPLÉMENTS PUBLIÉS PAR SONY.

TABLE OF CONTENTS

1. GENERAL	4
2. DISASSEMBLY	
2-1. Sub Panel Assy	10
2-2. CD Mechanism Block	10
2-3. Main Board	10
2-4. Heat Sink	11
2-5. Chassis (T) Assy	11
2-6. Lever Section	12
2-7. Servo Board	12
2-8. Arm Roller Assy	13
2-9. Chassis (OP) Assy	13
2-10. Optical Pick-up Block	14
3. DIAGRAMS	
3-1. IC Pin Descriptions	15
3-2. Block Diagram –CD Section–	23
3-3. Block Diagram –Tuner Section–	24
3-4. Block Diagram –Display Section–	25
3-5. Circuit Boards Location	26
3-6. Printed Wiring Boards –CD Mechanism Section–	28
3-7. Schematic Diagram –CD Mechanism Section (1/2)–	30
3-8. Schematic Diagram –CD Mechanism Section (2/2)–	31
3-9. Printed Wiring Boards –Main Section–	32
3-10. Schematic Diagram –Main Section (1/4)–	34
3-11. Schematic Diagram –Main Section (2/4)–	35
3-12. Schematic Diagram –Main Section (3/4)–	36
3-13. Schematic Diagram –Main Section (4/4)–	37
3-14. Printed Wiring Board –Sub (CD) Section–	38
3-15. Schematic Diagram –Sub (CD) Section–	39
3-16. Printed Wiring Board –Key Section–	40
3-17. Schematic Diagram –Key Section–	41
4. EXPLODED VIEWS	
4-1. Chassis Section	44
4-2. Front panel Section	45
4-3. CD Mechanism Section (1)	46
4-4. CD Mechanism Section (2)	47
4-5. CD Mechanism Section (3)	48
5. ELECTRICAL PARTS LIST	49

This section is extracted from AEP, UK model's instruction manual.

Location of controls

Card remote commander RM-X113

Refer to the pages listed for details.
CD/MD: During Playback **RADIO**: During radio reception **MENU**: During menu mode

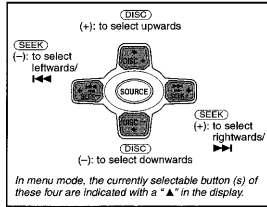
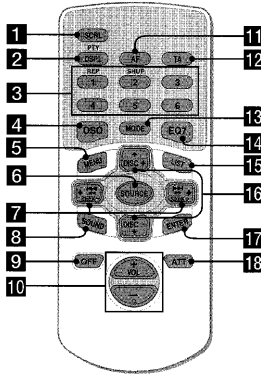

Tip
 Refer to "Replacing the lithium battery" for details on how to replace the batteries (page 30).

- 1 SCRL button 10
- 2 DSPL/PTY (display mode change/programme type) button 10, 11, 15, 18, 23, 29
- 3 Number buttons
 CD/MD
 ① REP 10
 ② SHUF 10
 RADIO 14, 16, 17, 20, 22
- 4 DSO button 28
- 5 MENU button 9, 11, 12, 13, 17, 19, 21, 23, 27, 28, 29
- 6 SOURCE (Power on/Radio/CD/MD) button 9, 10, 11, 13, 14, 17, 20, 27, 28
- 7 SEEK buttons (-/+) 26
 CD/MD 9
 RADIO 14, 16, 20
 MENU 9, 11, 12, 13, 19, 21, 23, 27, 28, 29
- 8 SOUND button 26
- 9 OFF (Stop/Power off) button 8, 9, 29
- 10 VOL buttons (+/-) 17

- 11 AF button 16, 17
- 12 TA button 17
- 13 MODE button
 CD/MD 10, 11
 RADIO 13, 14, 17, 20
- 14 EQ7 button 27
- 15 LIST button
 CD/MD 11, 12
 RADIO 15, 22
- 16 DISC buttons (+/-)
 CD/MD 10, 12
 RADIO 14, 15, 18, 20, 22, 23
 MENU 9, 11, 12, 13, 17, 19, 21, 23, 27, 28, 29
- 17 ENTER button
 CD/MD 12
 RADIO 15, 18, 22, 23
 MENU 9, 11, 12, 13, 17, 19, 21, 23, 27, 28, 29
- 18 ATT button 26

Main unit

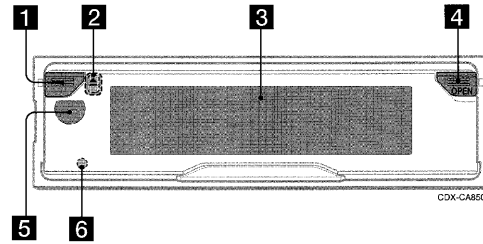

- 1 Power on/off button*
- 2 ▲ (eject) button (located on the front side of the unit, behind the front panel) 9
- 3 Display window
- 4 OPEN button 8, 9
- 5 Receptor for the card remote commander and rotary commander
- 6 RESET button (located on the front side of the unit, behind the front panel) 7

*** Warning when installing in a car without an ACC (accessory) position on the ignition switch**
 After turning off the ignition, be sure to press the power on/off button on the unit (or OFF) on the card remote commander or the rotary commander) for 2 seconds to turn off the clock display.
 Otherwise, the clock display does not turn off and this causes battery drain.
 To turn the unit on, press the power on/off button (1) on the unit.

Note
 If the unit is turned off by pressing the power on/off button on the unit (or OFF) on the card remote commander or the rotary commander) for 2 seconds, the unit cannot be operated with the card remote commander or the rotary commander unless the power on/off button on the unit is pressed or a disc is inserted to activate the unit.

Notes on CD-R/CD-RW discs

You can play CD-Rs (recordable CDs) designed for audio use on this unit. Look for this mark to distinguish CD-Rs for audio use.



This mark denotes that a disc is not for audio use.



- Some CD-Rs (depending on the equipment used for its recording or the condition of the disc) may not play on this unit.
- You cannot play a CD-R that is not finalized*.
- * A process necessary for a recorded CD-R disc to be played on the audio CD player.
- You cannot play CD-RWs (rewritable CDs) on this unit.

Getting Started

Resetting the unit

Before operating the unit for the first time, or after replacing the car battery or changing the connections, you must reset the unit. Remove the front panel and press the RESET button with a pointed object, such as a ballpoint pen.

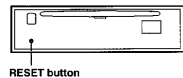

Note
 Pressing the RESET button will erase the clock setting and some stored contents.

Detaching the front panel

You can detach the front panel of this unit to protect the unit from being stolen.

Caution alarm

If you turn the ignition switch to the OFF position without removing the front panel, the caution alarm will beep for a few seconds. If you connect an optional amplifier and do not use the built-in amplifier, the beep sound will be deactivated.

- 1 Press the power on/off button on the unit (or OFF) on the card remote commander or the rotary commander*.
 CD/MD playback or radio reception stops (the display remains on).
 * If your car has no ACC position on the ignition switch, be sure to turn the unit off by pressing the power on/off button on the unit (or OFF) on the card remote commander or the rotary commander) for 2 seconds to avoid car battery drain.
- 2 Press OPEN, then slide the front panel to the right, and gently pull out the left end of the front panel.

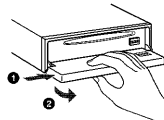

- Notes**
- If you detach the panel while the unit is still turned on, the power will turn off automatically to prevent the speakers from being damaged.
 - Do not drop or put excessive pressure on the front panel and its display window.
 - Do not subject the front panel to heat/high temperature or moisture. Avoid leaving it in parked cars or on dashboards/rear trays.

Tip
 When carrying the front panel with you, use the supplied front panel case.

Attaching the front panel

Place hole ① of the front panel onto the spindle ② on the unit, then lightly push the left side in.

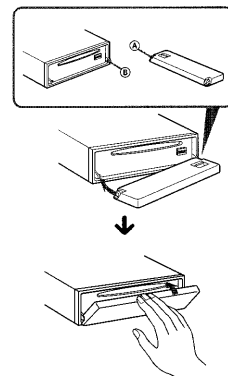

Note
 Do not put anything on the inner surface of the front panel.

Setting the clock

The clock uses a 24-hour digital indication.

Example: To set the clock to 10:08

- Press **(MENU)**, then press either side of **(DISC)** repeatedly until "Clock" appears.



- Press **(ENTER)**. The hour indication flashes.
- Press either side of **(DISC)** to set the hour.
- Press the (+) side of **(SEEK)**. The minute indication flashes.
- Press either side of **(DISC)** to set the minute.

- Press **(ENTER)**.

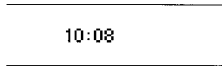

The clock starts. After the clock setting is completed, the display returns to normal play mode.

Tips

- You can set the clock automatically with the RDS feature (page 19).
- When D.Info mode is set to on, the time is always displayed (page 26).

CD Player CD/MD Unit (optional)

In addition to playing a CD with this unit, you can also control external CD/MD units.

Note

If you connect an optional CD unit with the CD TEXT function, the CD TEXT information will appear in the display when you play a CD TEXT disc.

Playing a disc

(With this unit)

- Press **(OPEN)** and insert the disc (labelled side up).

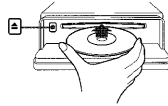

- Close the front panel. Playback starts automatically.

If a disc is already inserted, press **(SOURCE)** repeatedly until "CD" appears to start playback.

To	Press
Stop playback	(OFF)
Eject the disc	(OPEN) then (▲)
Skip tracks	(SEEK) ((◀▶))
- Automatic Music Sensor	[once for each track]
Fast-forward/reverse	(SEEK) ((▶▶◀◀))
- Manual Search	[hold to desired point]

continue to next page →

Notes

- When the last track on the disc is over, playback restarts from the first track of the disc.
- With optional unit connected, playback of the same source will continue on to the optional CD/MD unit.

(With optional unit)

- Press **(SOURCE)** repeatedly to select "CD" or "MD."
- Press **(MODE)** repeatedly until the desired unit appears. Playback starts.

To	Press
Skip discs	(DISC) (+/-)
- Disc selection	

Display items

When the disc/track changes, any prerecorded title* of the new disc/track is automatically displayed (if the Auto Scroll function is set to "on," names exceeding 8 characters will be scrolled (page 26)).

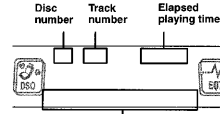

To	Press
Switch display item	(DISPL/PTY)
Scroll display item	(SCRL)

- *1 When pressing **(DISPL/PTY)**, "NO D Name" or "NO T Name" indicates that there is no Disc Memo (page 11) or prerecorded name to display.
- *2 Only for CD TEXT discs with the artist name.

Notes

- Some characters cannot be displayed.
- For some CD TEXT discs with very many characters, information may not scroll.
- This unit cannot display the artist name for each track of a CD TEXT disc.

Tip

When Auto scroll is set to off and the disc/track name is changed, the disc/track name does not scroll.

Playing tracks repeatedly

Repeat Play

The disc in the main unit will repeat a track or the entire disc when it reaches the end. For repeat play, you can select:

- Repeat 1 — to repeat a track.
- Repeat 2* — to repeat a disc.

* Available only when one or more optional CD/MD units are connected.

During playback, press **(REP)** repeatedly until the desired setting appears in the display. Repeat Play starts.

To return to normal play mode, select "Repeat off."

Playing tracks in random order

Shuffle Play

You can select:

- Shuf 1 — to play the tracks on the current disc in random order.
- Shuf 2* — to play the tracks in the current optional CD (MD) unit in random order.
- Shuf All** — to play all the tracks in all the connected CD (MD) units (including this unit) in random order.

*1 Available only when one or more optional CD (MD) units are connected.

*2 Available only when one or more optional CD units, or two or more optional MD units are connected.

During playback, press **(SHUF)** repeatedly until the desired setting appears in the display. Shuffle Play starts.

To return to normal play mode, select "Shuf off."

Note

"Shuf All" will not shuffle tracks between CD units and MD units.

Labelling a CD

— Disc Memo (For a CD unit with the CUSTOM FILE function)

You can label each disc with a custom name (Disc Memo). You can enter up to 8 characters for a disc. If you label a CD, you can locate the disc by name (page 12).

- Start playing the disc you want to label in a CD unit with the CUSTOM FILE function.
- Press **(MENU)**, then press either side of **(DISC)** repeatedly until "Name Edit" appears.
- Press **(ENTER)**.

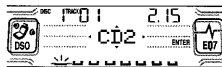

The unit will repeat the disc during the labelling procedure.

- Enter the characters.

- Press the (+)*1 side of **(DISC)** repeatedly to select the desired character.
A → B → C ... → 0 → 1 → 2 ... → + → * → ... → *2 → A

- *1 For reverse order, press the (-) side of **(DISC)**.
- *2 (blank space)

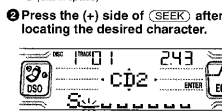

If you press the (-) side of **(SEEK)**, you can move back to the left.

- Repeat steps 1 and 2 to enter the entire name.
- To return to normal CD play mode, press **(ENTER)**.

Tips

- Simply overwrite or enter " " to correct or erase a name.
- There is another way to start labelling a CD: Press **(LIST)** for 2 seconds instead of performing steps 2 and 3. You can also complete the operation by pressing **(LIST)** for 2 seconds instead of step 5.
- You can label CDs on a unit without the CUSTOM FILE function if that unit is connected along with a CD unit that has the function. The Disc Memo will be stored in the memory of the CD unit with the CUSTOM FILE function.

Note

Repeat/shuffle play is suspended until the Name Edit is complete.

Viewing the Disc Memo

As a display item, the Disc Memo always takes priority over any original CD TEXT information.

To	Press
View	(DISPL/PTY) during CD/CD TEXT disc playback

Tip

To find out about other items that can be displayed, see page 10.

Erasing the Disc Memo

- Press **(SOURCE)** repeatedly to select "CD."
- Press **(MODE)** repeatedly to select the CD unit storing the Disc Memo.
- Press **(MENU)**, then press either side of **(DISC)** repeatedly until "Name Del" appears.
- Press **(ENTER)**. The stored names will appear.
- Press either side of **(DISC)** repeatedly to select the disc name you want to erase. The stored names will appear.
- Press **(ENTER)** for 2 seconds. The name is erased. Repeat steps 5 and 6 if you want to erase other names.
- Press **(MENU)** twice. The unit returns to normal CD play mode.

Notes

- When the Disc Memo for a CD TEXT disc is erased, the original CD TEXT information is displayed.
- If you cannot find the Disc Memo you want to erase, try selecting a different CD unit in step 2.

Locating a disc by name

— List-up (For a CD unit with the CD TEXT/CUSTOM FILE function, or an MD unit)

You can use this function for discs that have been assigned custom names*1 or for CD TEXT discs*2.

*1 Locating a disc by its custom name: when you assign a name for a CD (page 11) or an MD.

*2 Locating discs by the CD TEXT information: when you play a CD TEXT disc on a CD unit with the CD TEXT function.

- Press **(LIST)**. The name assigned to the current disc appears in the display.



- Press either side of **(DISC)** repeatedly until you find the desired disc.
- Press **(ENTER)** to play the disc.

Note

Some letters cannot be displayed (exception: Disc Memo).

Selecting specific tracks for playback

— Bank (For a CD unit with the CUSTOM FILE function)

If you label the disc, you can set the unit to skip or play the tracks of your choice.

- Start playing the disc you want to label.
- Press **(MENU)**, then press either side of **(DISC)** repeatedly until "Bank Sel" appears.
- Press **(ENTER)**.

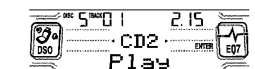

- Label the tracks.

- Press either side of **(SEEK)** repeatedly to select the track you want to label.
- Press **(ENTER)** repeatedly to select "Play" or "Skip."
- Repeat step 4 to set "Play" or "Skip" for all the tracks.
- Press **(MENU)** twice. The unit returns to normal CD play mode.

Notes

- You can set "Play" and "Skip" for up to 24 tracks.
- You cannot set "Skip" for all the tracks on a CD.

Playing specific tracks only

- You can select:
 - Bank on — to play the tracks with the “Play” setting.
 - Bank inv (Inverse) — to play the tracks with the “Skip” setting.

- 1 During playback, press **(MENU)**, then press either side of **(DISC)** repeatedly until “Bank on,” “Bank inv,” or “Bank off” appears.
- 2 Press the (+) side of **(SEEK)** repeatedly until the desired setting appears.

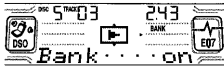

- 3 Press **(ENTER)**. Playback starts from the track following the current one.

To return to normal play mode, select “Bank off” in step 2.

Radio

The unit can store up to 6 stations per band (FM1, FM2, FM3, MW, and LW).

Caution
When tuning in stations while driving, use Best Tuning Memory to prevent accidents.

Storing stations automatically

— Best Tuning Memory (BTM)

The unit selects the stations with the strongest signals within the selected band, and stores them in the order of their frequency.

- 1 Press **(SOURCE)** repeatedly to select the radio.
- 2 Press **(MODE)** repeatedly to select the band.
- 3 Press **(MENU)**, then press either side of **(DISC)** repeatedly until “BTM” appears.
- 4 Press **(ENTER)**. A beep sounds when the setting is stored.

Notes

- If only a few stations can be received due to weak signals, some number buttons will retain their former settings.
- When a number is indicated in the display, the unit starts storing stations from the one currently displayed.

Receiving the stored stations

- 1 Press **(SOURCE)** repeatedly to select the radio.
- 2 Press **(MODE)** repeatedly to select the band.
- 3 Press the number button **(1 to 6)** on which the desired station is stored.

Tip
Press either side of **(DISC)** to receive the stations in the order they are stored in the memory (Preset Search function).

If preset tuning does not work

Press either side of **(SEEK)** to search for the station (automatic tuning). Scanning stops when the unit receives a station. Repeat until the desired station is received.

- Tips**
- If automatic tuning stops too frequently, turn on the Local Seek to limit seek to stations with stronger signals (see “Changing the sound and display settings” on page 26).
 - If you know the frequency of the station you want to listen to, press and hold either side of **(SEEK)** to locate the approximate frequency, then press **(SEEK)** repeatedly to fine adjust to the desired frequency (manual tuning).

If FM stereo reception is poor

Select monaural reception mode (see “Changing the sound and display settings” on page 26). The sound improves, but becomes monaural (“ST” disappears).

Tuning in a station through a list

— List-up

- 1 During radio reception, press **(LIST)** momentarily. The frequency or the name assigned to the current station appears in the display.

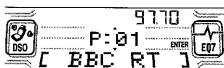

- 2 Press either side of **(DISC)** repeatedly until you find the desired station. If no name is assigned to the selected station, the frequency appears in the display.
- 3 Press **(ENTER)** to tune in the desired station.

RDS

Overview of RDS

FM stations with Radio Data System (RDS) service send inaudible digital information along with the regular radio programme signal. For example, one of the following will be displayed upon receiving a station with RDS capability.

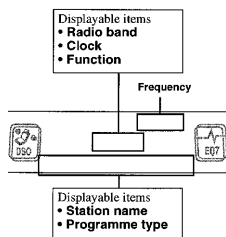

To	Press
Switch display item	(DSPL/PTY)

RDS services

- RDS data offers you other conveniences, such as:
- **Automatic retuning** of a programme, helpful during long-distance drives. — AF → page 16
 - Receiving **traffic announcements**, even when enjoying another programme/source. — TA → page 17
 - Selecting stations by the **type of programme** it broadcasts. — PTY → page 18
 - Automatic clock time setting. — CT → page 19
- Notes**
- Depending on the country or region, not all of the RDS functions are available.
 - RDS may not work properly if the signal strength is weak or if the station you are tuned to is not transmitting RDS data.

Automatic retuning for best reception results

— AF function

The alternative frequencies (AF) function allows the radio to always tune into the area’s strongest signal for the station you are listening to.

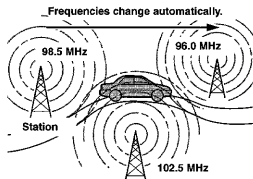

- 1 Select an FM station (page 13).
- 2 Press **(AF)** repeatedly until “AF on” appears. The unit starts searching for an alternative frequency with a stronger signal in the same network. If “NO AF” flashes, the currently tuned into station does not have an alternative frequency.

Note
When there is no alternative frequency in the area or when you do not need to search for one, turn the AF function off by selecting “AF off.”

Storing only the desired stations

You can manually preset the desired stations on any chosen number button.

- 1 Press **(SOURCE)** repeatedly to select the radio.
- 2 Press **(MODE)** repeatedly to select the band.
- 3 Press either side of **(SEEK)** to tune in the station that you want to store.
- 4 Press the desired number button **(1 to 6)** for 2 seconds until “MEM” appears. The number button indication appears in the display.

Note
If you try to store another station on the same number button, the previously stored station will be erased.

For stations without alternative frequencies

Press either side of **(SEEK)** while the station name is flashing (within 8 seconds). The unit starts searching for another frequency with the same PI (Programme Identification) data (“PI Seek” appears). If the unit cannot find the same PI, the unit returns to the previously selected frequency.

Staying with one regional programme

When AF function is on: this unit’s factory-set setting restricts reception to a specific region, so you won’t be switched to another regional station with a stronger frequency. If you leave this regional programme’s reception area or would like to take advantage of the whole AF function, select “REG off” from the MENU (page 27).

Note
This function does not work in the United Kingdom and in some other areas.

Local Link function (United Kingdom only)

This function enables you to select other local stations in the area, even if they are not stored on your number buttons.

- 1 Press a number button **(1 to 6)** that has a local station stored on it.
- 2 Within 5 seconds, press the number button of the local station again.
- 3 Repeat this procedure until the desired local station is received.

Receiving traffic announcements

— TA/TP

By activating the Traffic Announcement (TA) and Traffic Programme (TP), you can automatically tune in an FM station broadcasting traffic announcements. These settings function regardless of the current FM programme/source, CD/MD; the unit switches back to the original source when the bulletin is over.

Press **(TA)** repeatedly until "TA on" appears.

The unit starts searching for traffic information stations. "TP" indicates reception of such stations, and "TA" flashes during an actual traffic announcement. The unit will continue searching for stations available with TP if "NO TP" is indicated.

To cancel all traffic announcements, select "TA off."

To	Press
Cancel current announcement	(TA)

Tip
You can also cancel the current announcement by pressing **(SOURCE)** or **(MODE)**.

Presetting the volume of traffic announcements

You can preset the volume level of the traffic announcements so you won't miss hearing them.

1 Press **(VOL)** to adjust the desired volume level.

2 Press **(TA)** for 2 seconds. "TA" appears and the setting is stored.

Receiving emergency announcements

If either AF or TA is on, the unit will switch to emergency announcements, if one comes in while listening to an FM station or CD/MD.

Presetting RDS stations with AF and TA setting

When you preset RDS stations, the unit stores each station's AF/TA setting (on/off) as well as its frequency. You can select a different setting (for AF, TA, or both) for individual preset stations, or the same setting for all preset stations. If you preset stations with "AF on," the unit automatically stores stations with the strongest radio signal.

Presetting the same setting for all preset stations

- 1 Select an FM band (page 13).
- 2 Press **(AF)** and/or **(TA)** to select "AF on" and/or "TA on."
Note that selecting "AF off" or "TA off" stores not only RDS stations, but also non-RDS stations.
- 3 Press **(MENU)**, then press either side of **(DISC)** repeatedly until "BTM" appears.
- 4 Press **(ENTER)** until "BTM" flashes.

Presetting different settings for each preset station

- 1 Select an FM band, and tune in the desired station (page 14).
- 2 Press **(AF)** and/or **(TA)** to select "AF on" and/or "TA on."
- 3 Press the desired number button (1 to 8) until "MEM" appears.

Repeat from step 1 to preset other stations.

Tuning in stations by programme type

— PTY

You can tune in a station by selecting the type of programme you would like to listen to.

Programme types	Display
News	News
Current Affairs	Affairs
Information	Info
Sports	Sport
Education	Educate
Drama	Drama
Culture	Culture
Science	Science
Varied	Varied
Popular Music	Pop M
Rock Music	Rock M
Easy Listening	Easy M
Light Classical	Light M
Classical	Classics
Other Music Type	Other M
Weather	Weather
Finance	Finance
Children's Programmes	Children
Social Affairs	Social A
Religion	Religion
Phone In	Phone In
Travel	Travel
Leisure	Leisure
Jazz Music	Jazz
Country Music	Country
National Music	Nation M
Oldies Music	Oldies
Folk Music	Folk M
Documentary	Document

Note
You cannot use this function in some countries where no PTY (Programme Type selection) data is available.

- 1 Press **(DISC/PTY)** during FM reception until "PTY" appears.



The current programme type name appears if the station is transmitting the PTY data. "-----" appears if the received station is not an RDS station, or if the RDS data is not received.

- 2 Press **(DISC)** repeatedly until the desired programme type appears. The programme types appear in the order shown in the table. "-----" appears if the programme type is not specified in the RDS data.
- 3 Press **(ENTER)**. The unit starts searching for a station broadcasting the selected programme type.

Setting the clock automatically

— CT

The CT (Clock Time) data from the RDS transmission sets the clock automatically.

- 1 During radio reception, press **(MENU)**, then press either side of **(DISC)** repeatedly until "CT off" appears.

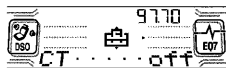

- 2 Press the (+) side of **(SEEK)** repeatedly until "CT on" appears. The clock is set.

- 3 Press **(ENTER)** to return to the normal display.

To cancel the CT function, select "CT off" in step 2.

Notes
• The CT function may not work even though an RDS station is being received.
• There might be a difference between the time set by the CT function and the actual time.

DAB (optional)

You can connect an optional DAB tuner to this unit.

Overview of DAB

DAB (Digital Audio Broadcasting) is a new multimedia broadcasting system that transmits audio programmes with a quality comparable to that of CDs. This is made possible by the use of a microcomputer in the DAB tuner which uses the radio signals sent from multiple aerials and multi-path signals (reflected radio waves) to boost the strength of the main signal. This makes DAB almost immune to radio interference even in a moving object such as a car.

Each DAB station bundles radio programmes (services) into an ensemble which it then broadcasts. Each service contains one or more components. All ensembles, services, and components are identified by name, so you can access any of them without having to know their frequencies.

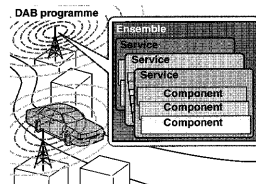

Notes
• The DAB system is still in a testing phase. Some services have not been sufficiently defined or are presently being tested. At present, such services are not supported by the optional DAB tuner unit XT-100DAB.
• DAB programmes are broadcast in Band-III (174 to 240 MHz) and L-Band (1,452 to 1,492 MHz), with each band divided into channels (41 in Band-III and 23 in L-Band). One ensemble is broadcast per channel by each DAB station.

Basic operations of DAB

Searching for the ensemble and service

— Automatic Tuning

- 1 Press **(SOURCE)** repeatedly to select the radio.
- 2 Press **(MODE)** repeatedly to select "DAB."
- 3 Press and hold either side of **(SEEK)** until "Seek +" or "Seek -" appears.

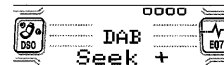

The unit will stop seeking when an ensemble is located. The unit will then automatically select the first service and display its name, and the display indicator will change from "Seek +"/"Seek -" to the service name.

- 4 Press either side of **(SEEK)** to select the desired service.

Selecting the ensemble

— Manual Tuning

If you know the channel number of ensemble, follow the procedure below to tune in.

- 1 Press **(SOURCE)** repeatedly to select the radio.
- 2 Press **(MODE)** repeatedly to select "DAB."
- 3 Press either side of **(DISC)** until "Ch. XXX" appears.

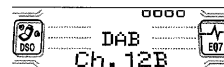

- 4 Press either side of **(DISC)** repeatedly until the desired channel number appears.

Receiving the preset services

Following procedure is available after presetting the service. For details on presetting the services, refer to "Presetting DAB services automatically," (page 21) and "Presetting DAB services manually" (page 21).

- 1 Press **(SOURCE)** repeatedly to select the radio.
- 2 Press **(MODE)** repeatedly to select "DAB."
- 3 Press either side of **(DISC)** repeatedly to select the preset service.

Tip
There is another way to receive the preset service (preset on numbers 1 to 6). Press the number button (1 to 6) on which the desired service is stored.

Refer to the level indication to check the receiving condition of the DAB programme. The level indication increases as the strength of the receiving signal increases.

level 1 level 2 level 3 level 4
- - - - - - - - - - - - - - - -

If no service of the selected programme type is available, "----" will be displayed. "----" will flash in the display if the reception is poor.

Note
To display the level indication, turn off the Motion Display (page 26).

Presetting DAB services automatically

— BTM

The BTM (Best Tuning Memory) function picks out DAB ensembles and automatically assigns the services within the ensembles to preset service numbers. The unit can preset up to 40 services.

If services have been previously set, the BTM function operates under the following conditions:

- If you activate the BTM function while listening to a preset service, the unit will store detected services (by overwriting) only to preset numbers higher than that of the current preset service.
- If you activate the function while listening to a service that is not preset, the unit will replace the contents of all preset numbers.
- In both cases above, if the unit detects a service that is identical to one already preset, the previously stored service remains unchanged and the newly detected service is not preset.

- 1 While listening to a DAB programme, press **(MENU)**.
- 2 Press either side of **(DISC)** repeatedly until "BTM" appears.
- 3 Press **(ENTER)**.
A beep sounds when the service is stored. After activating the BTM function, the unit tunes the service assigned in the preset memory 1 automatically.

Note
If the unit can only tune in a few services, the BTM function may not assign services to all the preset service numbers.

Presetting DAB services manually

— Preset Edit

You can also preset DAB services manually or delete a service which is already preset. Note that up to 40 services (preset either by the BTM function or manually) can be preset to the unit's memory.

- 1 While listening to a DAB programme, press **(MENU)**.
- 2 Press either side of **(DISC)** repeatedly until "PRS Edit" appears, then press **(ENTER)**.
- 3 Select the service and the preset number you want to preset.

- 1 Press either side of **(SEEK)** to select the service.
- 2 Press either side of **(DISC)** to select the preset number.

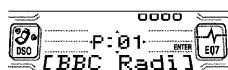

- 3 Press **(ENTER)**.
The Preset Edit commands will appear in the display.

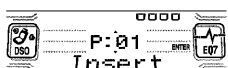

- 4 Press either side of **(DISC)** to select the desired command.

- 5 Press **(ENTER)**.
To edit other services, repeat steps 3 and 4.

continue to next page →

Replacing the services in preset memories

Press either side of **(DISC)** to select "Over Wrt" in step 4, then press **(ENTER)**.

Tip
There is another way to preset the service (on numbers 1 to 6).

After receiving the service, press the desired number button (**(1)** to **(6)**) until a beep sounds.

Adding the services in preset memories

Press either side of **(DISC)** to select "Insert" in step 4, then press **(ENTER)**.

Note
"Insert" does not appear if the maximum number of services (40) is already preset in memory.

Erasing the services in preset memories

Press either side of **(DISC)** to select "Delete" in step 4, then press **(ENTER)**.

Tuning in DAB programme through a list

Follow the procedure below to tune in a DAB programme manually.

- 1 While listening to a DAB programme, press **(LIST)** repeatedly until "E" (ensemble list) appears.

E: ensemble list
S: service list
C: component list
P: preset list



All available ensembles will be listed.

- 2 Press either side of **(DISC)** until the desired ensemble appears, then press **(ENTER)**.

The first service for the ensemble is selected automatically.

- 3 Press **(LIST)** repeatedly until "S" (service list) appears.

All services available for the ensemble will be listed.

- 4 Press either side of **(DISC)** repeatedly until the desired service appears, then press **(ENTER)**.

The first component for the service is selected automatically.

- 5 Press **(LIST)** repeatedly until "C" (component list) appears.

All components available for the service will be listed.

- 6 Press either side of **(DISC)** until the desired component appears, then press **(ENTER)**.

Automatic updating of the ensemble list

When you perform the BTM function for the first time, all the ensembles available in your area are automatically stored. When you perform the BTM function again, the contents of these lists are updated in accordance with the conditions described on page 21.

An ensemble is added to the respective list when it is received during Automatic Tuning or Manual Tuning but is unlisted.

An ensemble is also deleted from the respective list when:

- you select an ensemble from the list, but it cannot be received.
- you perform Automatic Tuning or Manual Tuning to receive a listed ensemble, service, or the component, but it cannot be received.

Switching multi-channel audio and DRC

DAB can contain multi-channel audio. You can select main or sub-channel for reception. Also, if you turn on the DRC (Dynamic Range Control) function, the dynamic range on the service which supports DRC can automatically be extended.

The following items can be set:

- **BLGL** — to select the channel from either "Main" (main-channel) or "Sub" (sub-channel).
- **DRC** — to turn on or off the function.

- 1 While listening to a DAB programme, press **(MENU)**.
- 2 Press either side of **(DISC)** repeatedly until "DRC" or "BLGL" appears.
- 3 Press either side of **(SEEK)** to select the desired setting (Example: "on" or "off").
- 4 Press **(ENTER)**.

Note
"BLGL" appears in the menu only when the unit is receiving a multi-channel programme.

Locating a DAB service by programme type (PTY)

You can use the PTY (Programme type selection) function to tune in the programme you want.

- 1 While listening to a DAB programme, press **(DISP/PTY)**.
- 2 Press either side of **(DISC)** repeatedly to select the programme type.



The programme types appear in the order shown on page 18.

- 3 Press **(ENTER)**.
Searching for a service of the selected programme type begins automatically.

Connection

Equipment used in illustrations (not supplied)
In Abbildungen dargestellte Geräte (nicht mitgeliefert)
Appareils utilisés dans les illustrations (non fournis)
Apparecchiatura utilizzata nelle illustrazioni (non in dotazione)
Apparaat gebruikt voor illustratiedoeleinden (niet meegeleverd)

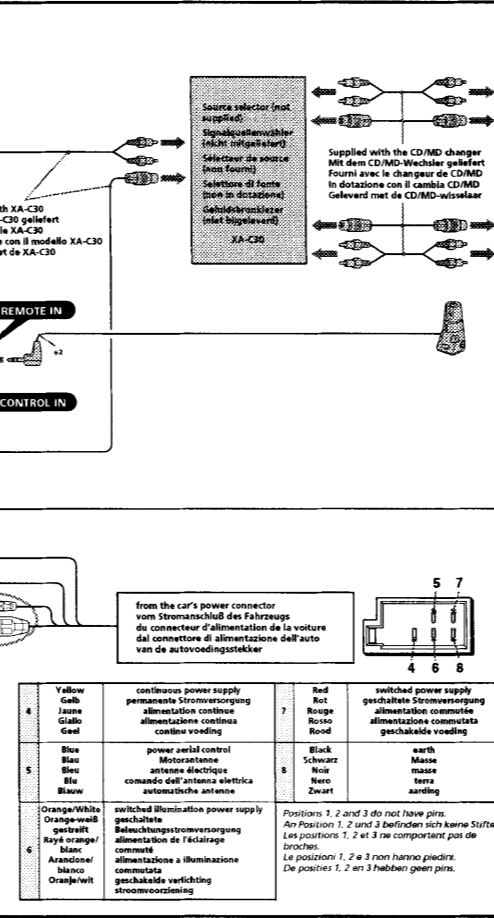
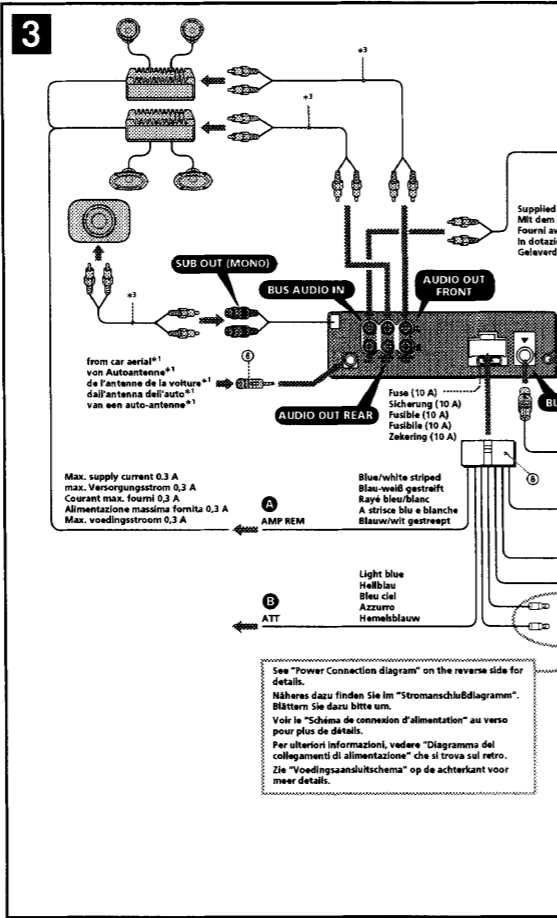
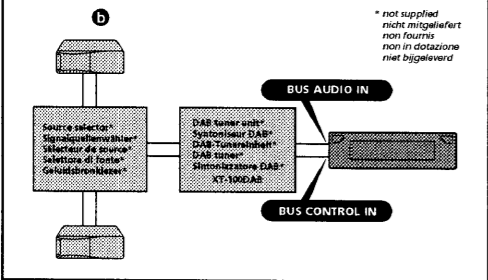
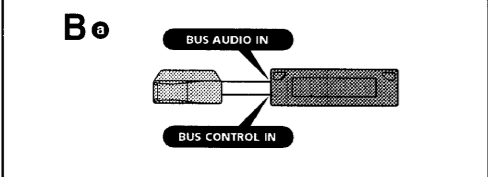
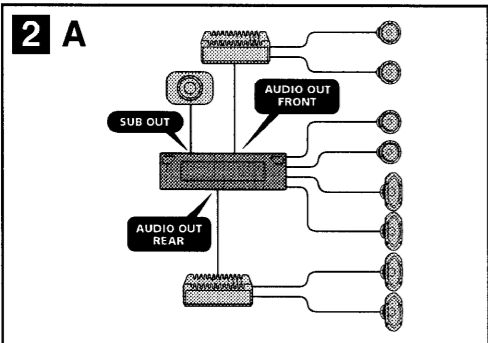

Notes and tables for antenna and speaker connections. Includes tables for antenna types and speaker polarity configurations.

Cautions
This unit is designed for negative earth 12 V DC operation only.
Do not get the wires under a screw, or caught in moving parts (e.g. seat racking).

Parts list
The numbers in the list are keyed to those in the instructions.



Connection example
Notes
Be sure to connect the earth cord before connecting the amplifier.



Warning
If you have a power aerial without a relay box, connecting this unit with the supplied power connecting cord may damage the aerial.

Précautions
Cet appareil est conçu pour fonctionner sur courant continu de 12 V avec masse négative.
Évitez de fixer des vis sur les câbles ou de coincer ceux-ci dans des pièces mobiles (par exemple, armature de siège).

Liste des composants
Les numéros de l'illustration correspondent à ceux des instructions.

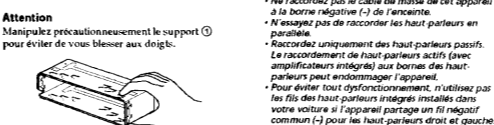

Exemple de raccordement
Remarques
Raccordez d'abord le fil de masse avant de raccorder l'amplificateur.



Attention
Manipulez précautionneusement le support pour éviter de vous blesser au doigt.

Vorsicht
Dieses Gerät ist ausschließlich für den Betrieb bei 12 V Gleichstrom (negative Erdung) bestimmt.

Teiliste
Die Nummern in der Liste sind dieselben wie in den Anleitungen.

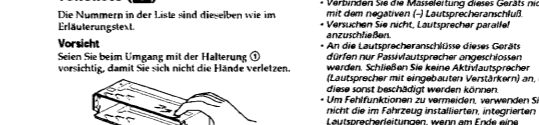

Anschlussbeispiel
Hinweise
Schließen Sie unbedingt zuerst das Massekabel an, bevor Sie den Verstärker anschließen.

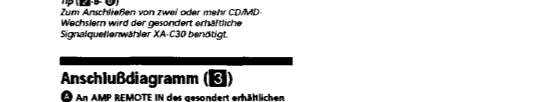

Warnung
Wenn Sie eine Motorantenne ohne Relaiskasten verwenden, kann durch Anschließen dieses Geräts mit dem mitgelieferten Stromversorgungskabel die Antenne beschädigt werden.

Attenzione
Questo apparecchio è stato progettato per l'uso solo a 12 V CC con massa negativa.
Evitare che i cavi rimangano bloccati da una vite o incastrati nelle parti mobili ad esempio nelle guide scorrevoli dei sedili.

Elenco dei componenti
I numeri nella lista corrispondono a quelli riportati nelle istruzioni.

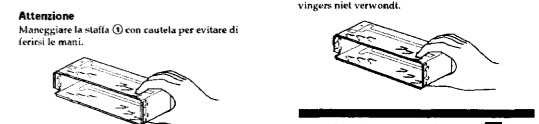

Esempi di collegamento
Nota
Assicurarsi di collegare il cavo di terra prima di collegare l'apparecchio all'amplificatore.

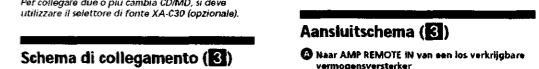

Schema di collegamento
Nota
Assicurarsi di collegare il cavo di terra prima di collegare l'apparecchio all'amplificatore.

Avvertenza
Quando si collega l'apparecchio con il cavo di alimentazione in dotazione, si potrebbe danneggiare l'antenna elettrica se questa non ha la spola di rick.

Note sui cavi di controllo
Il cavo di controllo dell'antenna elettrica (blu) fornisce corrente continua a 12 V CC quando si accende il sistema di autoradio.

Nota sul collegamento dei diffusori
Prima di collegare i diffusori spegnere l'apparecchio.

Nota sul collegamento dell'antenna
Se la vostra antenna di veicolo è di tipo ISO (International Organization for Standardization - International Normungsgemeinschaft) anziché quella di tipo ISO (International Organization for Standardization), montare il trasformatore di adattatore.

Nota sul collegamento dell'antenna
Se la vostra antenna di veicolo è di tipo ISO (International Organization for Standardization - International Normungsgemeinschaft) anziché quella di tipo ISO (International Organization for Standardization), montare il trasformatore di adattatore.

Nota sul collegamento dell'antenna
Se la vostra antenna di veicolo è di tipo ISO (International Organization for Standardization - International Normungsgemeinschaft) anziché quella di tipo ISO (International Organization for Standardization), montare il trasformatore di adattatore.

Nota sul collegamento dell'antenna
Se la vostra antenna di veicolo è di tipo ISO (International Organization for Standardization - International Normungsgemeinschaft) anziché quella di tipo ISO (International Organization for Standardization), montare il trasformatore di adattatore.

Nota sul collegamento dell'antenna
Se la vostra antenna di veicolo è di tipo ISO (International Organization for Standardization - International Normungsgemeinschaft) anziché quella di tipo ISO (International Organization for Standardization), montare il trasformatore di adattatore.

Nota sul collegamento dell'antenna
Se la vostra antenna di veicolo è di tipo ISO (International Organization for Standardization - International Normungsgemeinschaft) anziché quella di tipo ISO (International Organization for Standardization), montare il trasformatore di adattatore.

Nota sul collegamento dell'antenna
Se la vostra antenna di veicolo è di tipo ISO (International Organization for Standardization - International Normungsgemeinschaft) anziché quella di tipo ISO (International Organization for Standardization), montare il trasformatore di adattatore.

Nota sul collegamento dell'antenna
Se la vostra antenna di veicolo è di tipo ISO (International Organization for Standardization - International Normungsgemeinschaft) anziché quella di tipo ISO (International Organization for Standardization), montare il trasformatore di adattatore.

Nota sul collegamento dell'antenna
Se la vostra antenna di veicolo è di tipo ISO (International Organization for Standardization - International Normungsgemeinschaft) anziché quella di tipo ISO (International Organization for Standardization), montare il trasformatore di adattatore.

Nota sul collegamento dell'antenna
Se la vostra antenna di veicolo è di tipo ISO (International Organization for Standardization - International Normungsgemeinschaft) anziché quella di tipo ISO (International Organization for Standardization), montare il trasformatore di adattatore.

Nota sul collegamento dell'antenna
Se la vostra antenna di veicolo è di tipo ISO (International Organization for Standardization - International Normungsgemeinschaft) anziché quella di tipo ISO (International Organization for Standardization), montare il trasformatore di adattatore.

**SECTION 2
DISASSEMBLY**

Note : This equipment can be removed using the following procedure.

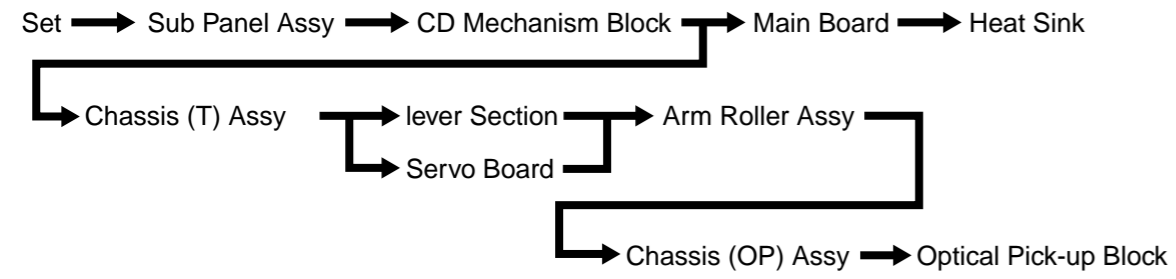

2-2. CD MECHANISM BLOCK

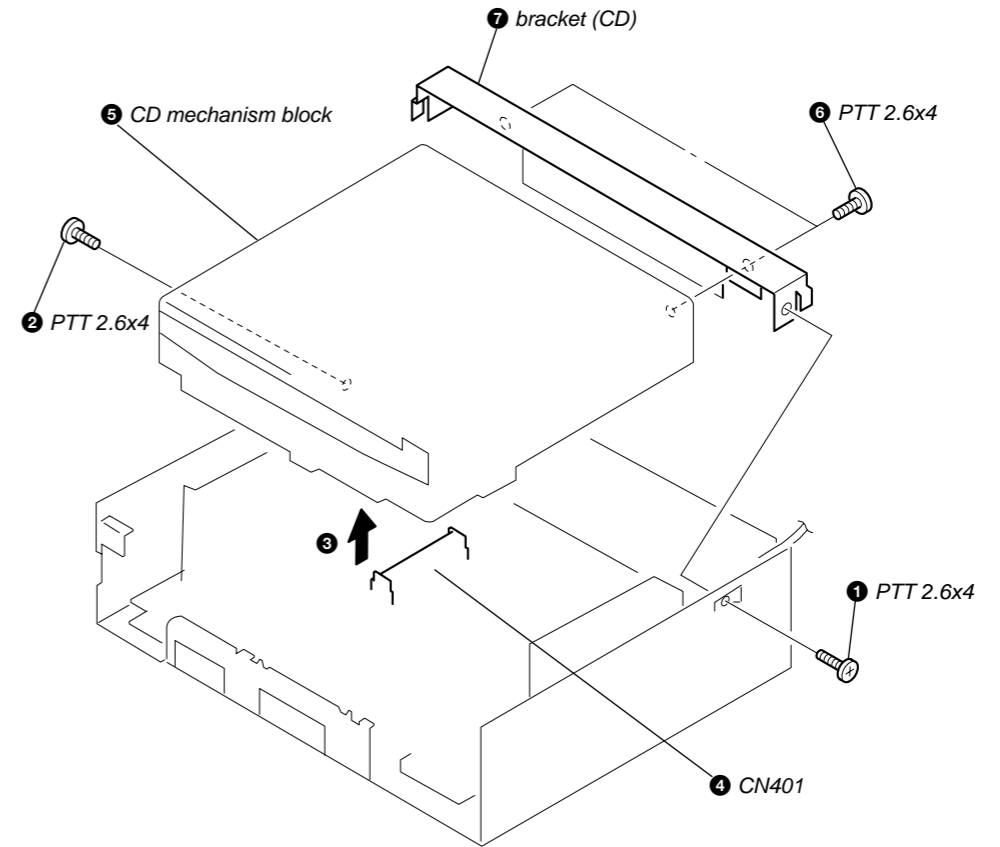

Note : Follow the disassembly procedure in the numerical order given.

2-1. SUB PANEL ASSY

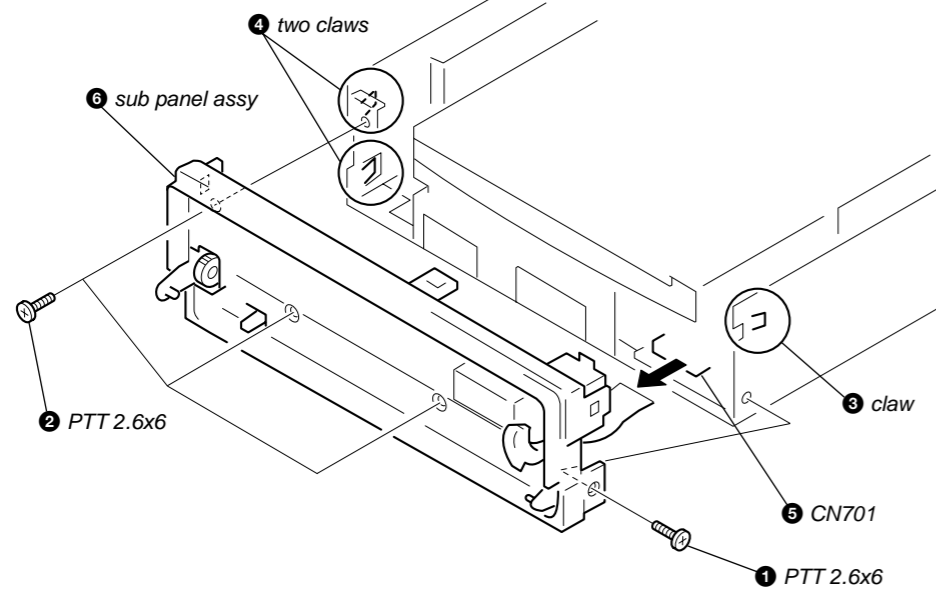

2-3. MAIN BOARD

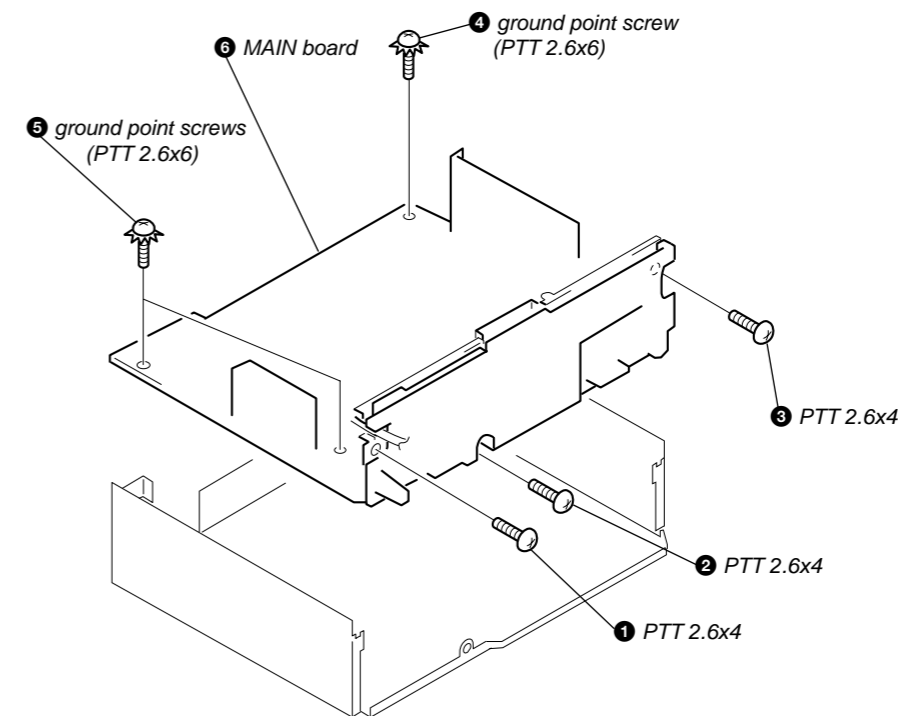

2-4. HEAT SINK

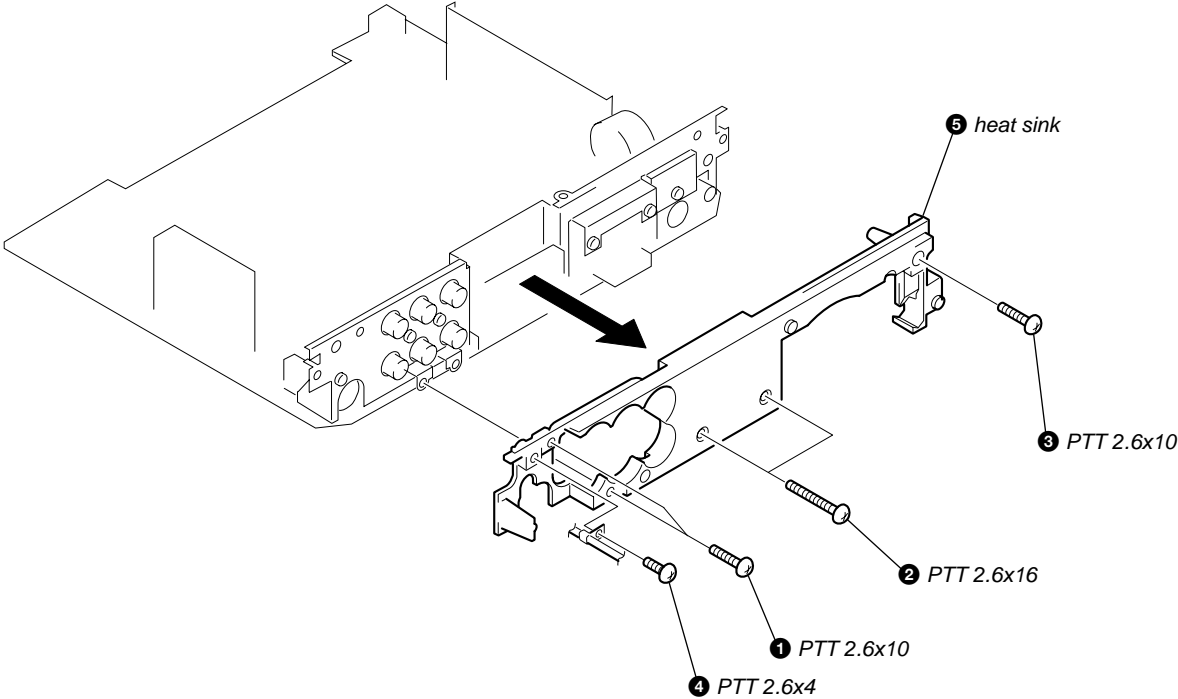

2-5. CHASSIS (T) ASSY

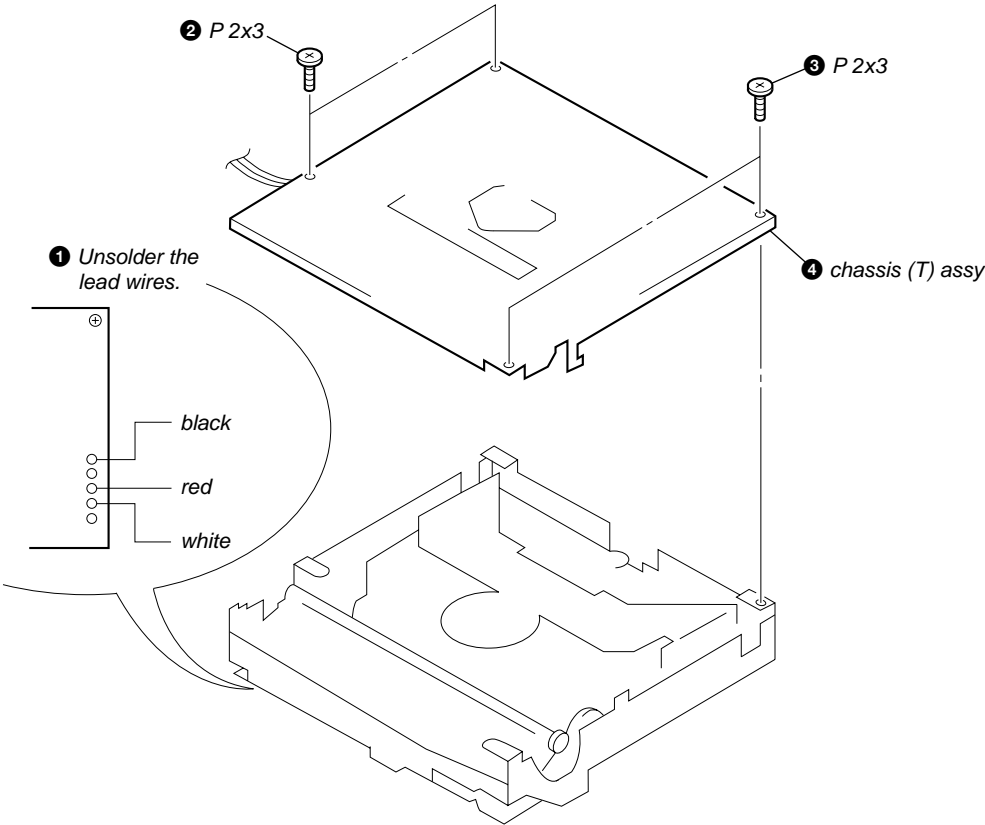

2-6. LEVER SECTION

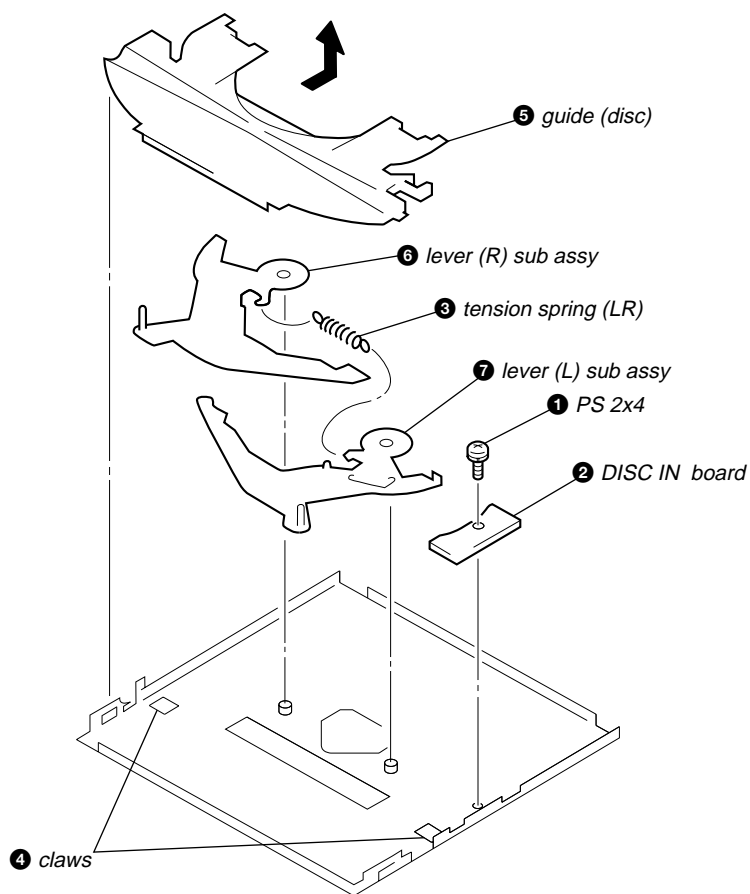

2-7. SERVO BOARD

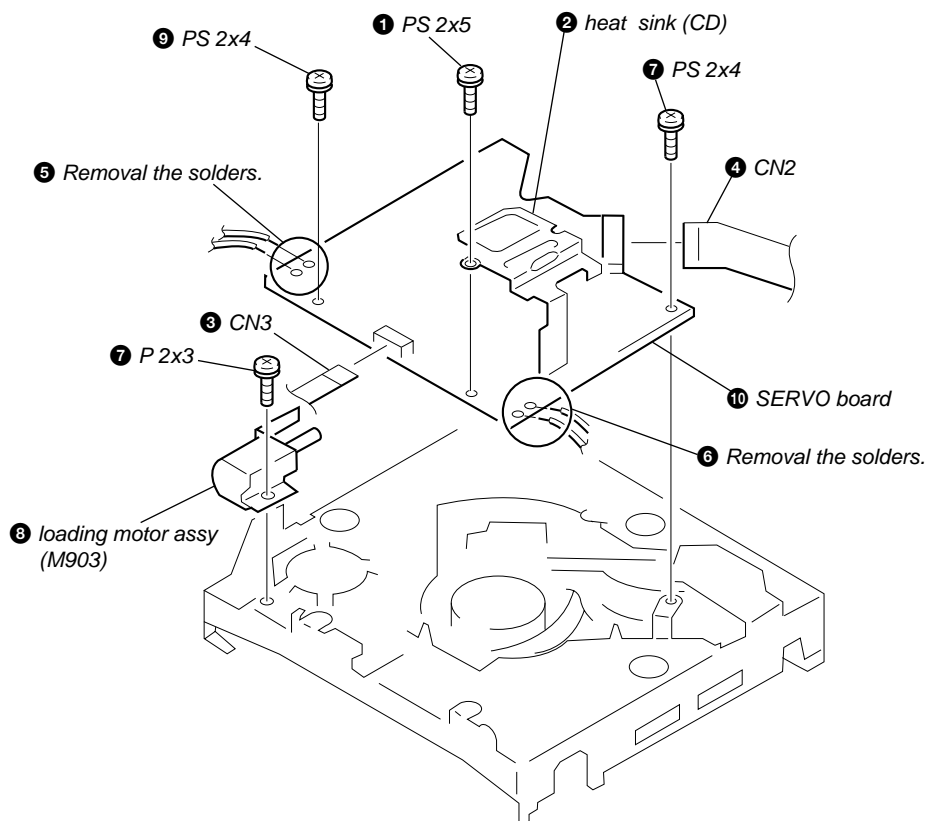

2-8. ARM ROLLER ASSY

- When installing, take note of the positions arm (roller) and washers. (Fig. 1)

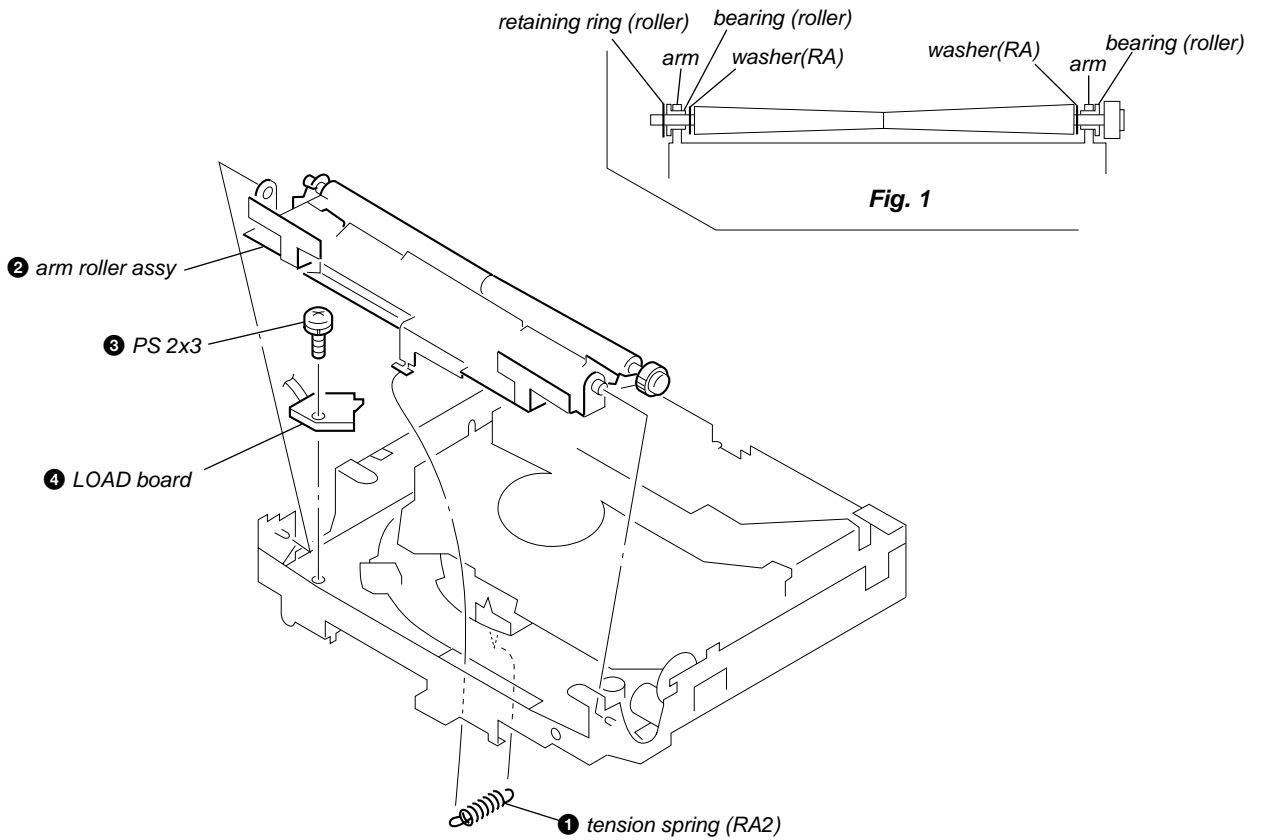

2-9. CHASSIS (OP) ASSY

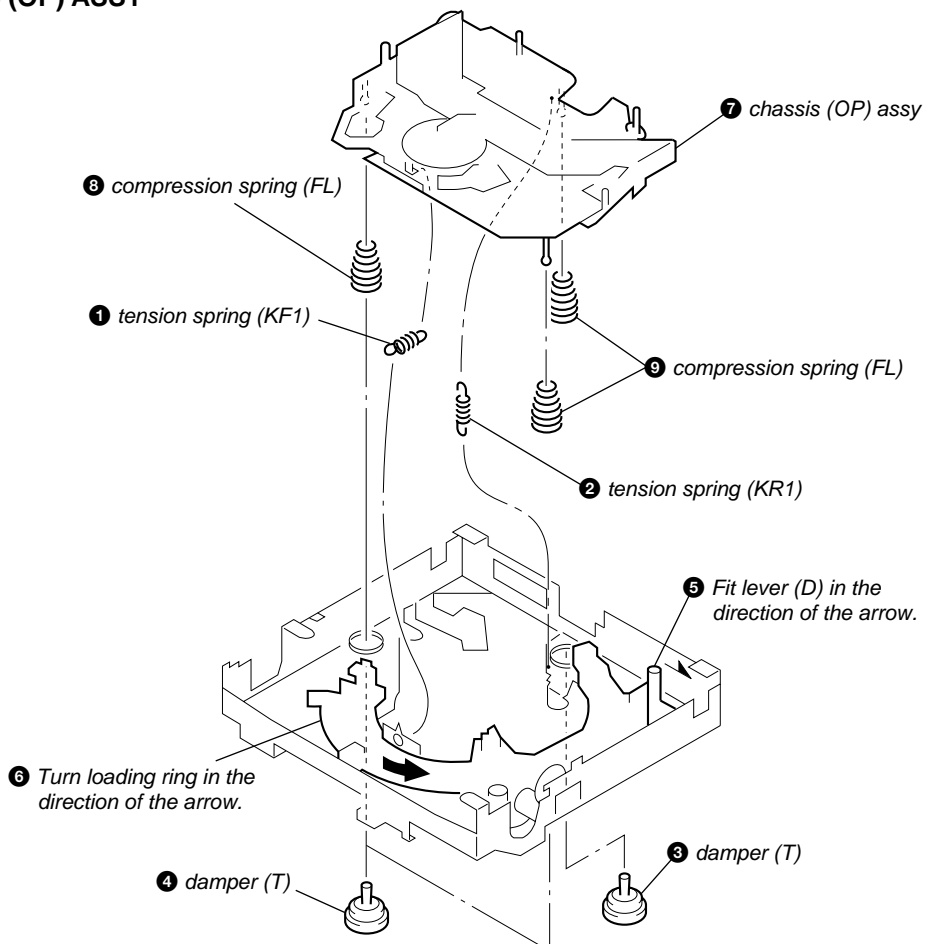

2-10. OPTICAL PICK-UP BLOCK

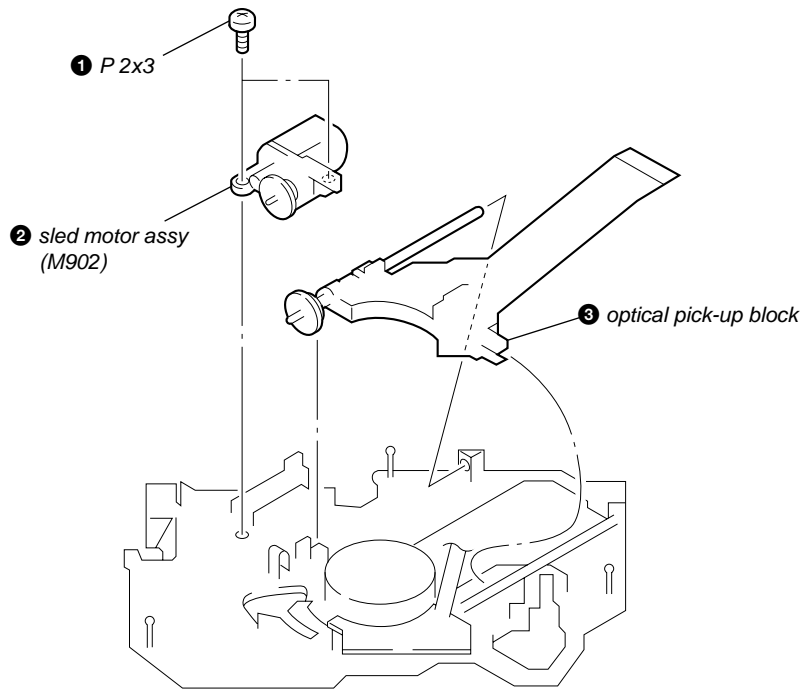

SECTION 3 DIAGRAMS

3-1. IC PIN DESCRIPTIONS

• IC501 CXD2598Q (DIGITAL SERVO, DIGITAL SIGNAL PROCESSOR) (SERVO BOARD)

Pin No.	Pin Name	I/O	Pin Description
1	DVDD	—	Digital power supply pin
2	DVSS	—	Digital ground
3	SOUT	O	Servo brock serial data output (Not used.)
4	SOCK	O	Servo brock serial data read clock output (Not used.)
5	XOLT	O	Servo brock serial data latch output (Not used.)
6	SQSO	O	Sub Q 80 bit, PCM peak and level data output. CD TEXT data output
7	SQCK	I	Clock input from SQSO read output.
8	SCSY	I	Fixed at “L”.
9	SBSO	O	Serial output of sub-P to W. (Not used.)
10	EXCK	I	Clock input from SBSO read output. (Fixed at “L”)
11	XRST	I	System reset (“L”: Reset)
12	STSM	I	System mute input (Fixed at “L”)
13	DATA	I	Serial data input from CPU.
14	XLAT	I	Latch input from CPU. Latch serial data at the falling edge.
15	CLOK	I	Serial data transfer clock input from CPU.
16	SENS	O	SENS output for CPU.
17	SCLK	I	Clock input from SENS serial data read.
18	ATSK	I/O	Input/output for anti-shock.
19	WFCK	O	WFCK (Write Flame Clock) output (Not used.)
20	XUGF	O	XUGF output (Not used.)
21	XPCK	O	XPCK output (Not used.)
22	GFS	O	GFS output
23	C2PO	O	C2PO output (Not used.)
24	SCOR	O	“H” output at either detection, sub code sync S0 or S1.
25	C4M	O	4.2336 MHz output (Not used.)
26	WDCK	O	Word clock input $f=2Fs$ (Not used.)
27	COUT	I/O	Track number count signal input/output (Not used.)
28	MIRR	I/O	Mirror signal input/output (Not used.)
29	DVSS	—	Digital ground
30	DVDD	—	Digital power supply pin
31	DFCT	I/O	Diffect signal input/output (Not used.)
32	FOK	I/O	Focus OK signal output
33	PWM1	I	External control input of spindle motor.
34	LOCK	I/O	Lock signal input/output
35	MDP	O	Servo control output of spindle motor.
36	SSTP	I	Disc most inner track detection signal input
37	FSTIO	I/O	2/3 frequency division output of pins ⑥ and ⑦. (Not used.)
38	SFDR	O	Sled drive output
39	SRDR	O	Sled drive output
40	TFDR	O	Tracking drive output
41	TRDR	O	Tracking drive output
42	FFDR	O	Focus drive output
43	FRDR	O	Focus drive output
44	DVDD	—	Digital power supply pin
45	DVSS	—	Digital ground
46	TEST	I	Test pin (Fixed at “L”)
47	TES1	I	Test pin (Fixed at “L”)
48	XTSL	I	X’tal select input (“L”: 16.9344 MHz, “H”: 33.8688 MHz)
49	VC	I	Center voltage input
50	FE	I	Focus error signal input
51	SE	I	Sled error signal input

CDX-CA850/CA850X/CA860X

Pin No.	Pin Name	I/O	Pin Description
52	TE	I	Tracking error signal input
53	CE	I	Center servo analog input
54	RFDC	I	RF signal input
55	ADIO	O	Test pin (Not used.)
56	AVSSO	—	Analog ground
57	IGEN	I	Constant current input from OP amplifier.
58	AVDDO	—	Analog ground
59	ASYO	O	EFM full-swing output (“L”: VSS, “H”: VDD)
60	ASYI	I	Asymmetry compare voltage input
61	RFAC	I	EFM signal input
62	AVSS3	—	Analog ground
63	CLTV	I	VCO control voltage input from master.
64	FILO	O	Filter output for master PLL (slave=digital PLL)
65	FILI	I	Filter input from master PLL.
66	PCO	O	Charge pump output for master PLL.
67	AVDD3	—	Analog power supply pin
68	BIAS	I	Asymmetry circuit constant current input
69	VCTL	I	VCO2 control input from wideband EFM PLL. (Not used.)
70	V16M	O	VCO2 oscillator output for wideband EFM PLL. (Not used.)
71	VPCO	O	Charge pump output for wideband EFM PLL. (Not used.)
72	DVSS	—	Digital ground
73	MD2	I	Digital out ON/OFF control input (“L”: OFF, “H”: ON)
74	DOUT	O	Digital out output
75	ASYE	I	Asymmetry circuit ON/OFF input (“L”: OFF, “H”: ON)
76	DVDD	—	Digital power supply pin
77	LRCK	O	D/A interface LR clock output (f=Fs)
78	LRCKI	I	D/A interface LR clock input
79	PCMD	O	D/A interface serial data output (2’s COMP, MSB fast)
80	PCMDI	I	D/A interface serial data input (2’s COMP, MSB fast)
81	BCK	O	D/A interface bit clock output
82	BCKI	I	D/A interface bit clock input
83	EMPH	O	Emphasis ON/OFF signal output
84	EMPHI	I	Emphasis ON/OFF signal input (“H”: ON, “L”: OFF)
85	XVDD	—	Power supply for master clock.
86	XTAI	I	X’tal oscillator input from master clock (16.9344 MHz).
87	XTAO	O	X’tal oscillator output for master clock (16.9344 MHz).
88	XVSS	—	Ground pin for master clock.
89	AVDD1	—	Analog power supply pin
90	AOUT1	O	Lch analog output
91	AIN1	I	Lch OPAMP input
92	LOUT1	O	Lch LINE output
93	AVSS1	—	Analog ground
94	AVSS2	—	Analog ground
95	LOUT2	O	Rch LINE output
96	AIN2	I	Rch OPAMP input
97	AOUT2	O	Rch analog output
98	AVDD2	—	Analog power supply pin
99	RMUT	O	Rch “0” detect Flug (Not used.)
100	LMUT	O	Lch “0” detect Flug (Not used.)

• IC5 CXP84640-072Q (CD SYSTEM CONTROL) (SERVO BOARD)

Pin No.	Pin Name	I/O	Pin Description
1	ITRPT	—	Not used in this set.
2, 3	—	—	Not used in this set.
4, 5	NCO	—	Not used in this set.
6	OPEN	I	Front panel open detection input
7	CLOSE	O	Front panel close control output
8	LINKOFF	I	Bus interface link input
9	NCO	—	Not used in this set.
10	$\overline{D SW}$	I	Down switch input (SW4)
11	SSTP	I	Limit switch input (SW3)
12, 13	NCO	—	Not used in this set.
14, 15	—	—	Not used in this set.
16	EMPH O	O	De-emphasis ON/OFF control output
17	CDMON	O	CD mechanism deck power control output
18	CD ON	O	CD power control output
19	A MUT	O	System attenuate control output
20	$\overline{LD ON}$	O	Laser power ON/OFF control output
21	$\overline{CD RST}$	O	CD system reset output
22	HOLD	O	Hold switch output
23	AGC CONT	O	AGC control output
24	—	—	Not used in this set.
25	PH3	I	Not used in this set.
26	$\overline{TSTIN0}$	I	Not used in this set.
27	$\overline{TSTIN1}$	I	Not used in this set.
28	$\overline{TST.CLV}$	I	Not used in this set.
29	NCO	—	Not used in this set.
30	\overline{RESET}	I	System reset input (“L”=Reset)
31	X IN	I	X’tal oscillator input from system clock. (10 MHz)
32	$\overline{X OUT}$	O	X’tal oscillator output for system clock. (10 MHz)
33	GND	—	Analog ground
34	$\overline{XT OUT}$	O	Not used in this set.
35	XT IN	I	Not used in this set.
36	AVSS	—	A/D converter ground
37	AVREF	I	A/D converter reference voltage input
38	TEP L	I	Not used in this set.
39	TEP H	I	Not used in this set.
40	SLED-	I	Sled drive input
41	PH2	I	Not used in this set.
42	SEK/SMET	I	Fixed at “H” in this set.
43	GFS/MNT2 SEL	I	Fixed at “H” in this set.
44	SC-JIG ON/OFF	I	Fixed at “H” in this set.
45	SCLK	O	CD-TEXT data read clock output
46	LOCK	I/O	Lock signal input/output
47	—	—	Not used in this set.
48	SCK2	O	Sub Q read clock output
49	SI2	I	Sub Q 80 bit, PCM peak and level data 16 bit input.
50	—	—	Not used in this set.
51	BUS CLK	I/O	Bus system serial clock input/output
52	BUS SI	I	Bus system serial interface input
53	BUS SO	O	Bus system serial interface output
54	F OK	I	Focus OK signal input
55	GFS	I	GFS signal detection input
56	TEST MODE	I	Fixed at “H” in this set.

CDX-CA850/CA850X/CA860X

Pin No.	Pin Name	I/O	Pin Description
57	SENS	I	SENS signal input
58	—	—	Not used in this set.
59	—	—	Not used in this set.
60	BU.IN	I	Back-up power detection input
61	$\overline{\text{BUSON}}$	I	Bus on control input
62	$\overline{\text{IN SW}}$	I	Disc in switch input (SW1)
63	$\overline{\text{SELF SW}}$	I	Self switch input (SW2)
64	SCOR	O	Sub-code sync output
65	CD-CKO	O	CD signal process serial clock input
66	LM LOD	O	Loading motor control output
67	CD DATA	O	CD signal process serial data output
68	CD-XLAT	O	CD signal process serial data latch output
69	LM-EJ	O	Loading motor control output
70	DRV-OE	O	Focus/tracking coil/sled motor control output
71	MD2	O	Digital out ON/OFF control output (“L”: OFF, “H”: ON)
72	VDD	—	Power supply pin
73	NIH	I	Fixed at “H” in this set.
74	V/Z	I	Fixed at “H” in this set.
75	PH1	I	Not used in this set.
76	—	—	Not used in this set.
77	DOUT-SEL	I	Fixed at “H” in this set.
78 – 80	—	—	Not used in this set.

- IC501 MB90574BPMT-G-323-BND (MAIN SYSTEM CONTROL) (CDX-CA850X/CA860X) (MAIN BOARD)
- IC501 MB90574BPMT-G-324-BND (MAIN SYSTEM CONTROL) (CDX-CA850) (MAIN BOARD)

Pin No.	Pin Name	I/O	Pin Description
1 – 4	NCO	O	Not used. (Open)
5	ATT	O	System mute control signal output
6, 7	NCO	O	Not used. (Open)
8	VCC	—	Power supply pin (+5 V)
9	AMP ATT	O	Amp mute signal output
10	E2PSIO	I/O	EEPROM data signal input/output
11	E2PCKO	O	EEPROM clock signal output
12	DOOR SW/FLS SI	I	Door switch signal input (L: close) Flash write data signal input
13	FLS SO	O	Flash write data signal output
14	BUS ON	O	BUS ON control signal output
15	BEEP	O	Beep signal output
16	NS MASK	O	Tuner mute signal output
17	UNISI	I	SONY BUS data signal input
18	UNISO	O	SONY BUS data signal output
19	UNICKO	O	SONY BUS clock signal output
20	IFWIDTH	O	Not used. (Open)
21	SWSHIFT	O	Not used. (Open)
22	SYSRST	O	System reset signal output
23	(NCO)	O	Not used. (Open)
24	SIRCS	I	Remote control data signal input
25 – 29	NCO	O	Not used. (open)
30	AMPON	O	Amp on signal output (L: OFF/H: ON)
31	VOLATT	O	Electronic volume mute signal output (L: Mute on)
32	NCO	O	Not used. (Open)
33	VSS	—	Ground pin
34	C	—	Power stabilized capacitance pin Not used. (open)
35 – 37	NCO	O	Not used. (Open)
38	DVCC	—	D/A converter VREF input
39	DVSS	—	D/A converter GND pin
40, 41	(NCO)	O	Not used. (Open)
42	AVCC	—	Analog power supply pin (+5 V)
43	AVRH	—	A/D converter VREF+ input
44	AVRL	—	A/D converter VREF- input
45	AVSS	—	Analog ground pin
46	KEYIN0	I	Key signal input 0
47	KEYIN1	I	Key signal input 1
48	RCIN0	I	Rotary commander signal input
49	NCO	O	Not used. (Open)
50	QUALITY	O	Quality signal output
51	FM AGC	O	Not used in this set. (Open)
52	MPTH	O	MPTH signal output to RDS decoder
53	VSM	I	S-meter signal input
54	VCC	—	Power supply pin (+5 V)
55, 56	NCO	O	Not used. (Open)
57	BOOT	O	Display microcomputer write control signal output
58	DOORIND	O	Front panel indicator signal output
59 – 62	NIL	I	Not used. (Connect to ground in this set.)
63	VSS	—	Ground pin
64	NIL	I	Not used. (Connect to ground in this set.)
65	FSW IN	O	Not used. (Open)
66 – 68	NCO	O	Not used. (Open)

CDX-CA850/CA850X/CA860X

Pin No.	Pin Name	I/O	Pin Description
69	FLASH W	I	Flash write mode detection signal input
70	I2CSIO	O	Tuner, electronic volume communication data signal output
71	I2CCKO	O	Tuner, electronic volume communication clock signal output
72	NCO	O	Not used. (Open)
73	X1A	I	Low speed oscillation signal input (32.768 kHz)
74	X0A	I	Low speed oscillation signal input (32.768 kHz)
75	DAVN	O	DAVN signal output to RDS decoder
76	DISCON IN	O	Not used. (Open)
77	BUIN	I	Backup power supply detection signal input
78	NCO	O	Not used. (Open)
79	KEYACK	I	KEY ACK detection signal input
80	ADON	O	A/D conversion power control signal output
81	NOSESW	I	Front panel attachment detection signal input
82	FLASH ON	O	Flash write jig power supply output
83	PWON	O	System power supply control signal output
84	NCO	O	Not used. (Open)
85	RAMBU	I	RAM reset detection signal input
86	HSTX	I	Hardware standby signal input
87	MD2	I	Operation mode input (Connect to ground.)
88, 89	MD1, 0	I	Operation mode input (Connect to VCC.)
90	RESET	I	Microcomputer reset signal input
91	VSS	—	Ground pin
92	X0	I	High speed oscillation signal input (3.68 MHz)
93	X1	I	High speed oscillation signal input (3.68 MHz)
94	VCC	—	Power supply pin (+5 V)
95, 96	REIN0, 1	I	Rotary encoder signal input
97 – 99	NCO	O	Not used. (Open)
100	4V SEL X/O	I	4 V/5.5 V preout menu with/without initial setting input
101	COLORSEL X/O	I	Illumination select with/without initial setting input Not used. (Open)
102	MODELSEL0 U/J	I	Destination setting input Not used. (Open)
103	DOT/L-CUBE	I	DOT/L-CUBE judgment initial setting input
104	CD/MD	I	CDX/MDX judgment initial setting input Not used. (Open)
105, 106	NCO	O	Not used. (Open)
107	RCIN1 (PULL UP)	I	Rotary commander signal input
108	TESTIN (PULL UP)	I	Test mode setting detection input
109	TELATT	I	TEL mute detection signal input
110	ILLIN	I	Illumination line detection signal input
111, 112	NCO	O	Not used. (Open)
113	TUNON	O	Tuner on signal output
114, 115	NCO	O	Not used. (Open)
116	EMPH	O	Not used. (Open)
117	ACCIN	I	ACC power supply detection signal input L: ACC ON
118	NCO	O	Not used. (Open)
119	VSS	—	Ground pin
120	NCO	O	Not used. (Open)

• IC701 HD6432355A35F (SUB SYSTEM CONTROL)

Pin No.	Pin Name	I/O	Pin Description
1	PG3	O	Spectrum analyzer clock output
2	PG4	O	Not used (open)
3	VSS	—	Ground pin
4	NC	—	Not used (open)
5	VCC	—	Power supply pin
6 – 9	PC0 – PC3	O	Not used (open)
10	VSS	—	Ground pin
11 – 14	PC4 – PC7	O	Not used (open)
15 – 18	PB0 – PB3	O	Not used (open)
19	VSS	—	Ground pin
20 – 23	PB4 – PB7	O	Not used (open)
24 – 27	PA0 – PA3	O	Not used (open)
28	VSS	—	Ground pin
29 – 32	PA4 – PA7	O	Not used (open)
33	SP LAT(PWON)	I	Spectrum analyzer latch input
34	BU IN	I	Back-up power detection input
35	VSS	—	Ground pin
36	VSS	—	Ground pin
37	P65	O	Not used (open)
38	BUS ON	I	Bus on control signal
39	VCC	—	Power supply pin
40 – 43	PE0 – PE3	O	Not used (open)
44	VSS	—	Ground pin
45 – 48	PE4 – PE7	O	Not used (open)
49	PD0	O	Not used (open)
50	LINK OFF	O	Bus interface link off control signal
51	PD2	O	Not used (open)
52	ILL-ON	O	Illumination on/off switch signal output
53	VSS	—	Ground pin
54 – 56	PD4 – PD6	O	Not used (open)
57	BOOT	I	Flash write-in mode detection input
58	VCC	—	Power supply pin
59	NC	—	Not used (open)
60	TX/LCD DATA	O	Flash write-in data/LCD driver data output
61	SP SI	O	Not used (open)
62	RX	I	Flash write-in data input
63	L RST	O	Reset signal for SIRCS inveter
64	LCD SCK	O	LCD driver clock output
65	VSS	—	Ground pin
66	LCD CE1	O	LCD driver chip enable output
67	VSS	—	Ground pin
68	VSS	—	Ground pin
69	LCD INH1	O	Not used (open)
70	LCD CE2	O	Not used (open)
71	LCD INH2	O	Not used (open)
72 – 78	P27 – P21	O	Not used (open)
79	P20	O	Flash write-in control signal
80	FWE L	I	Flash write-in enable input
81	RES	I	Reset signal
82	NMI	I	Non maskable interrupt signal
83	STBY		Standby mode signal
84	VCC	—	Power supply pin

CDX-CA850/CA850X/CA860X

Pin No.	Pin Name	I/O	Pin Description
85	XTAL	—	Crystal oscillator (18.432 MHz)
86	EXTAL	—	Crystal oscillator (18.432 MHz)
87	VSS	—	Ground pin
88	PF7	O	Not used (open)
89	VCC	—	Power supply pin
90 – 96	PF6 – PF0	O	Not used (open)
97	UNI SO	O	SONY Bus data output
98	UNI SI	I	SONY Bus data input
99	VSS	—	Ground pin
100	VSS	—	Ground pin
101	UNI SCK	I	SONY Bus clock input
102	P53	O	Not used (open)
103	AVCC	—	Power supply pin for A/D converter
104	VREF	—	Reference voltage for A/D converter
105 – 111	P42 – P46	O	Not used (Connecting to ground.)
112	P47(SA DATA)	I	Spectrum analyzer data input
113	AVSS	—	Ground pin
114	VSS	—	Ground pin
115 – 122	P17 – P10	O	Not used (open)
123	MD0	—	Mode select
124	MD1	—	Mode select
125	MD2	—	Mode select
126 – 128	PG0 – PG2	O	Not used (open)

3-2. BLOCK DIAGRAM — CD SECTION —

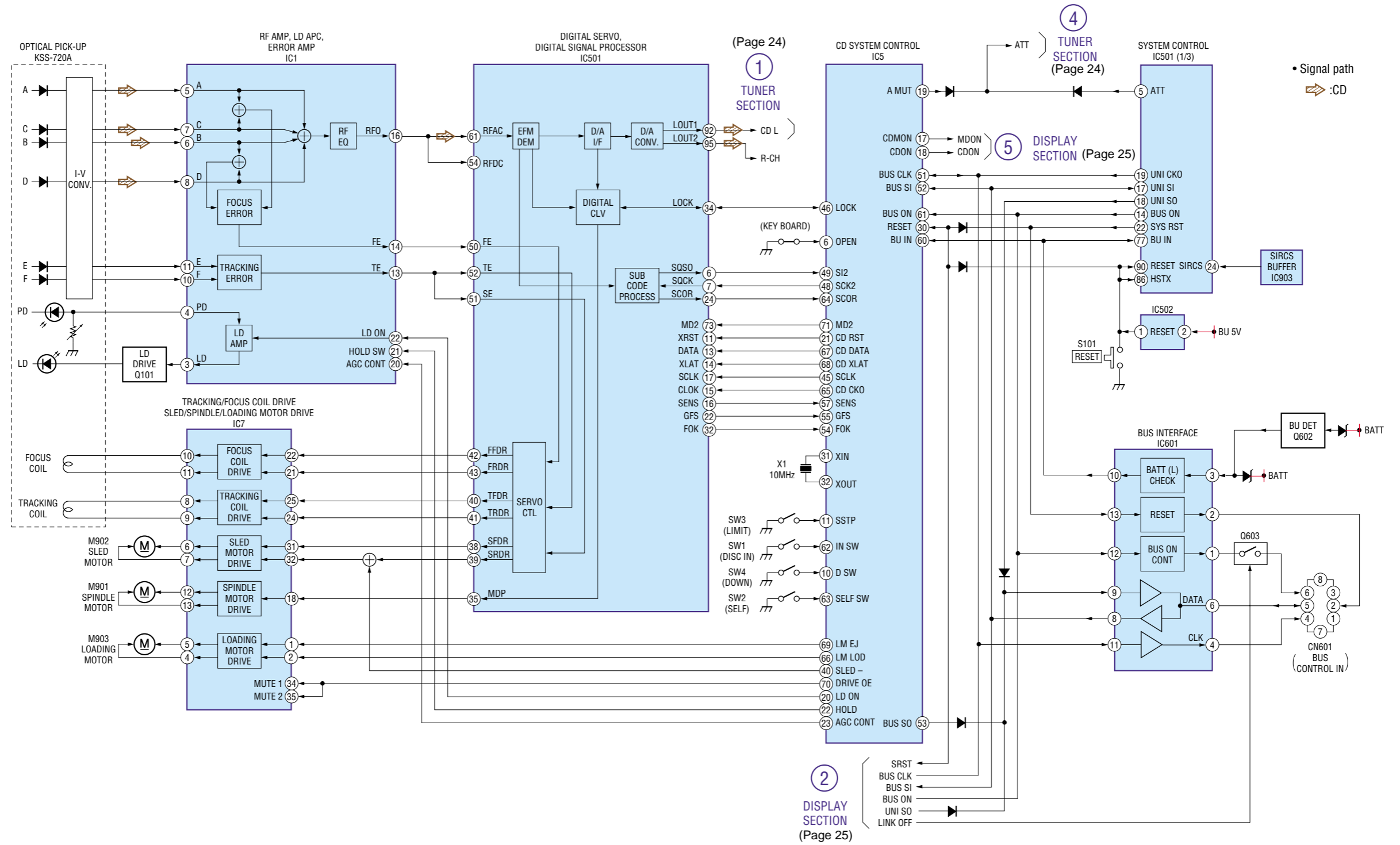

3-3. BLOCK DIAGRAM — TUNER SECTION —

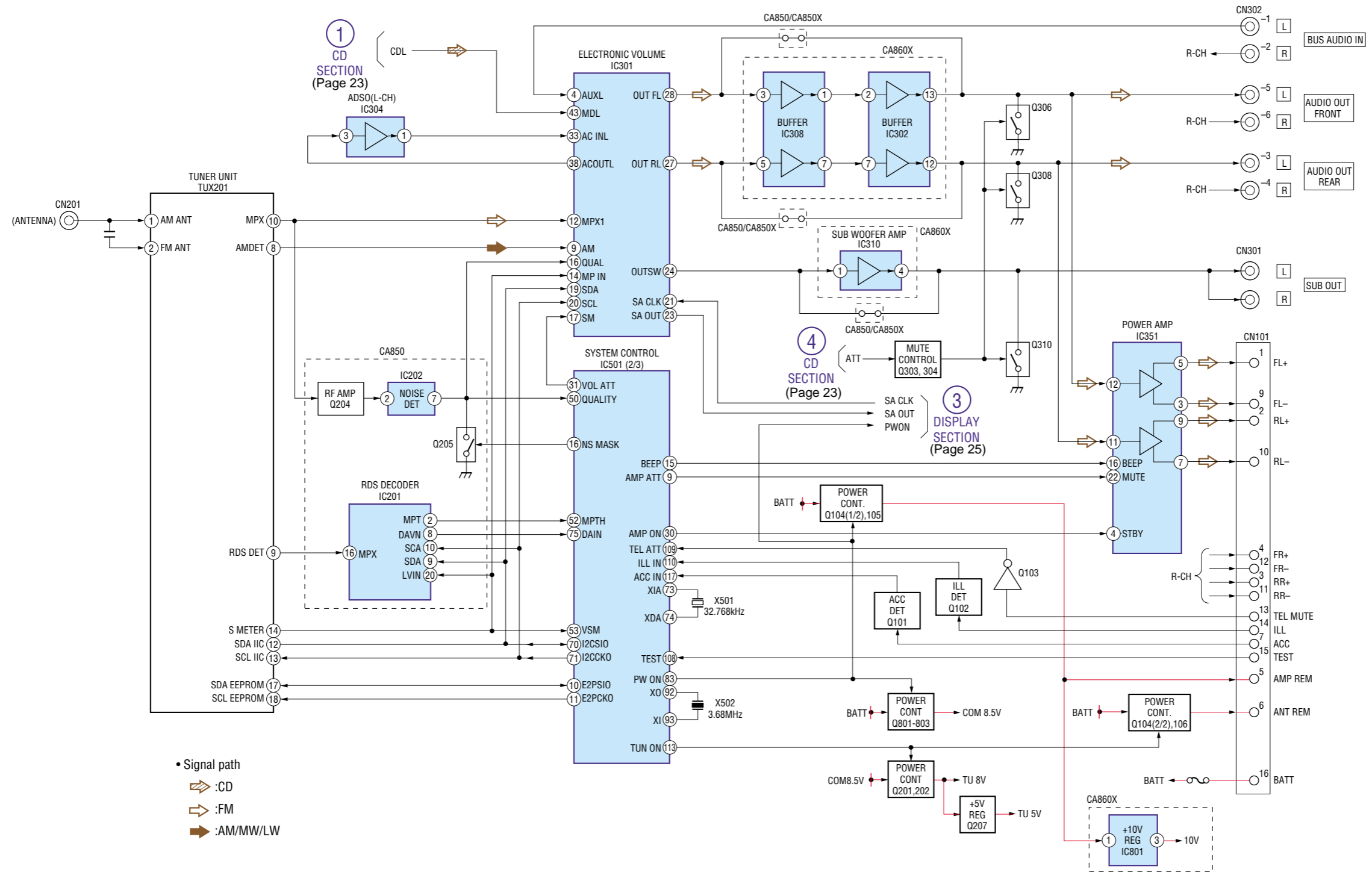

3-4. BLOCK DIAGRAM — DISPLAY SECTION —

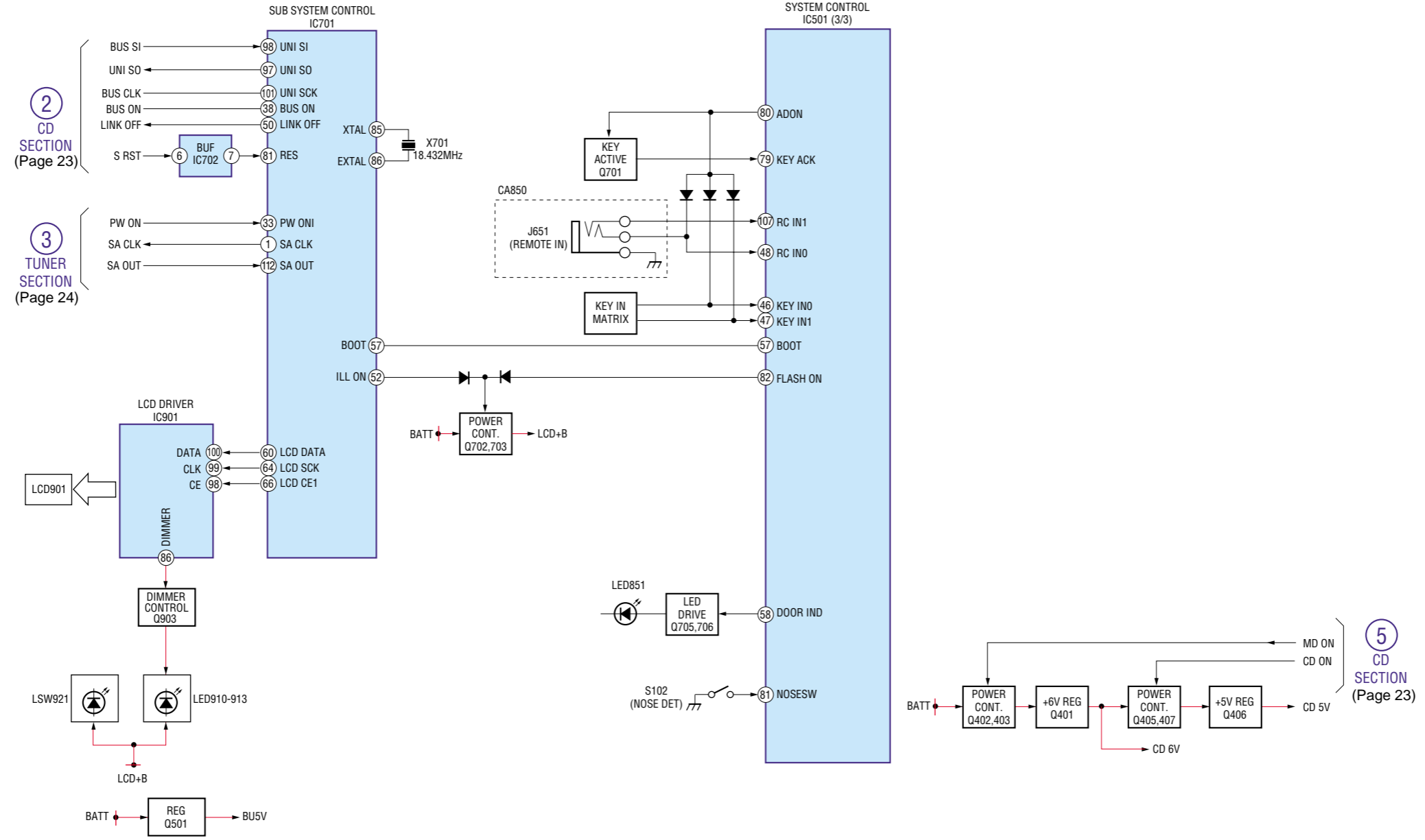

3-5. CIRCUIT BOARDS LOCATION

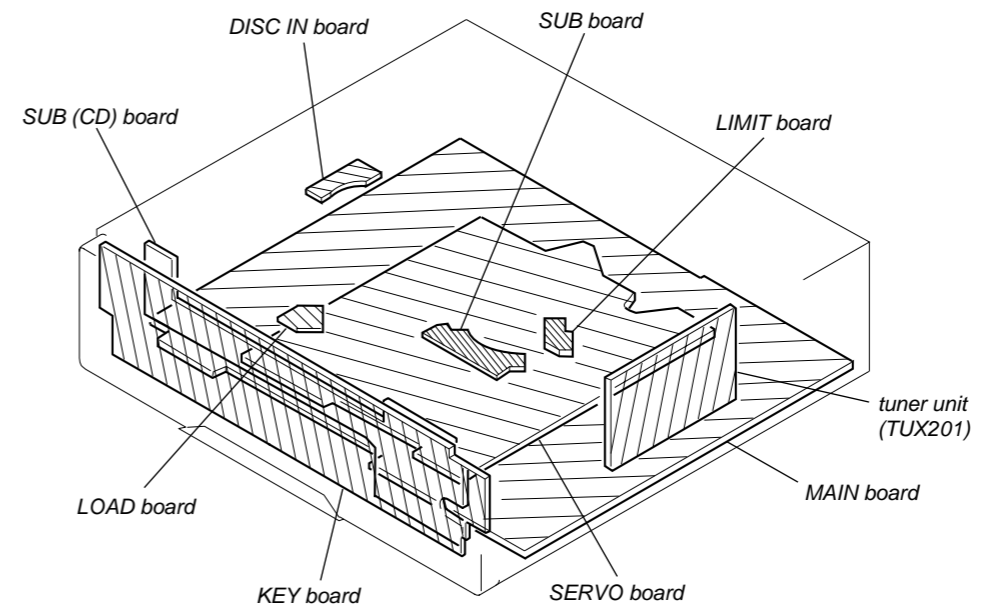

THIS NOTE IS COMMON FOR PRINTED WIRING BOARDS AND SCHEMATIC DIAGRAMS.
(In addition to this, the necessary note is printed in each block.)

for schematic diagram:

- All capacitors are in μF unless otherwise noted. pF: μpF
- 50 WV or less are not indicated except for electrolytics and tantalums.
- All resistors are in Ω and $1/4\text{W}$ or less unless otherwise specified.
- % : indicates tolerance.
- Δ : internal component.
- \square : panel designation.

Note:
The components identified by mark Δ or dotted line with mark Δ are critical for safety.
Replace only with part number specified.

Note:
Les composants identifiés par une marque Δ sont critiques pour la sécurité.
Ne les remplacer que par une pièce portant le numéro spécifié.

- **—** : B+ Line.
- Power voltage is dc 14.4V and fed with regulated dc power supply from ACC and BATT cords.
- Voltages are taken with a VOM (Input impedance 10 M Ω). Voltage variations may be noted due to normal production tolerances.
- Waveforms are taken with an oscilloscope. Voltage variations may be noted due to normal production tolerances.
- Circled numbers refer to waveforms.
- Signal path.
 - \Rightarrow : FM
 - \Rightarrow : AM/MW/LW
 - \Rightarrow : CD

for printed wiring boards:

- \circ : parts extracted from the component side.
- \square : parts extracted from the conductor side.
- \blacksquare : parts mounted on the conductor side.
- \circ : Through hole.
- \blacksquare : Pattern from the side which enables seeing. (The other layer's patterns are not indicated.)

Caution:

Pattern face side: Parts on the pattern face side seen from the (Side B) pattern face are indicated.
Parts face side: Parts on the parts face side seen from the (Side A) parts face are indicated.

• Waveforms

— Servo Board —

(MODE: CD PLAY)

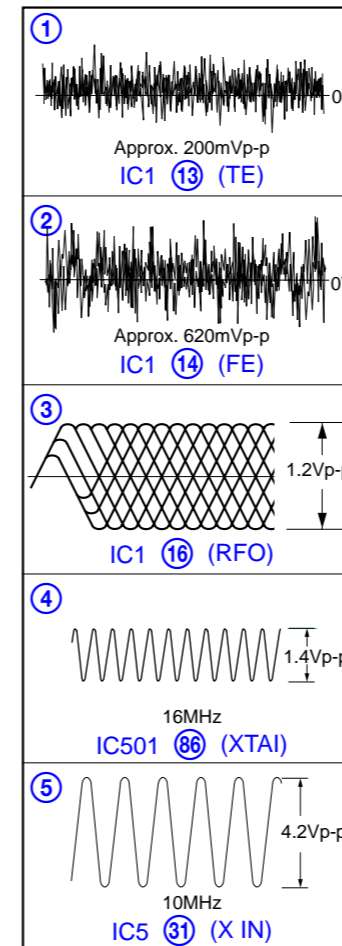

— Main Board —

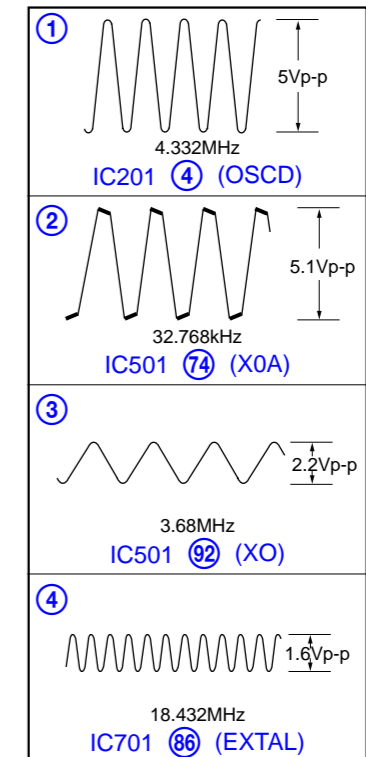

— Key Board —

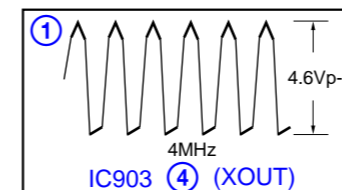

3-6. PRINTED WIRING BOARDS — CD MECHANISM SECTION —

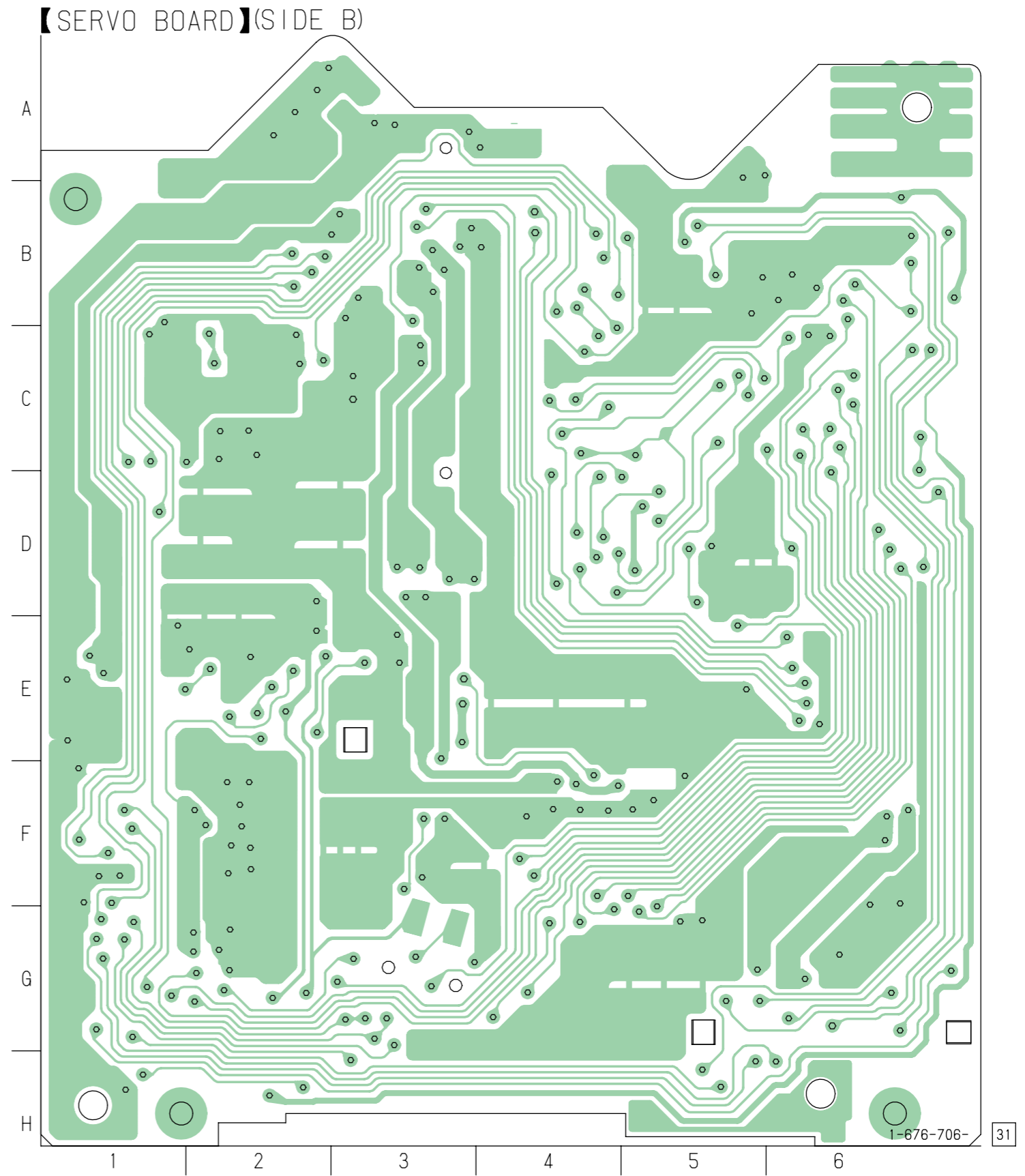

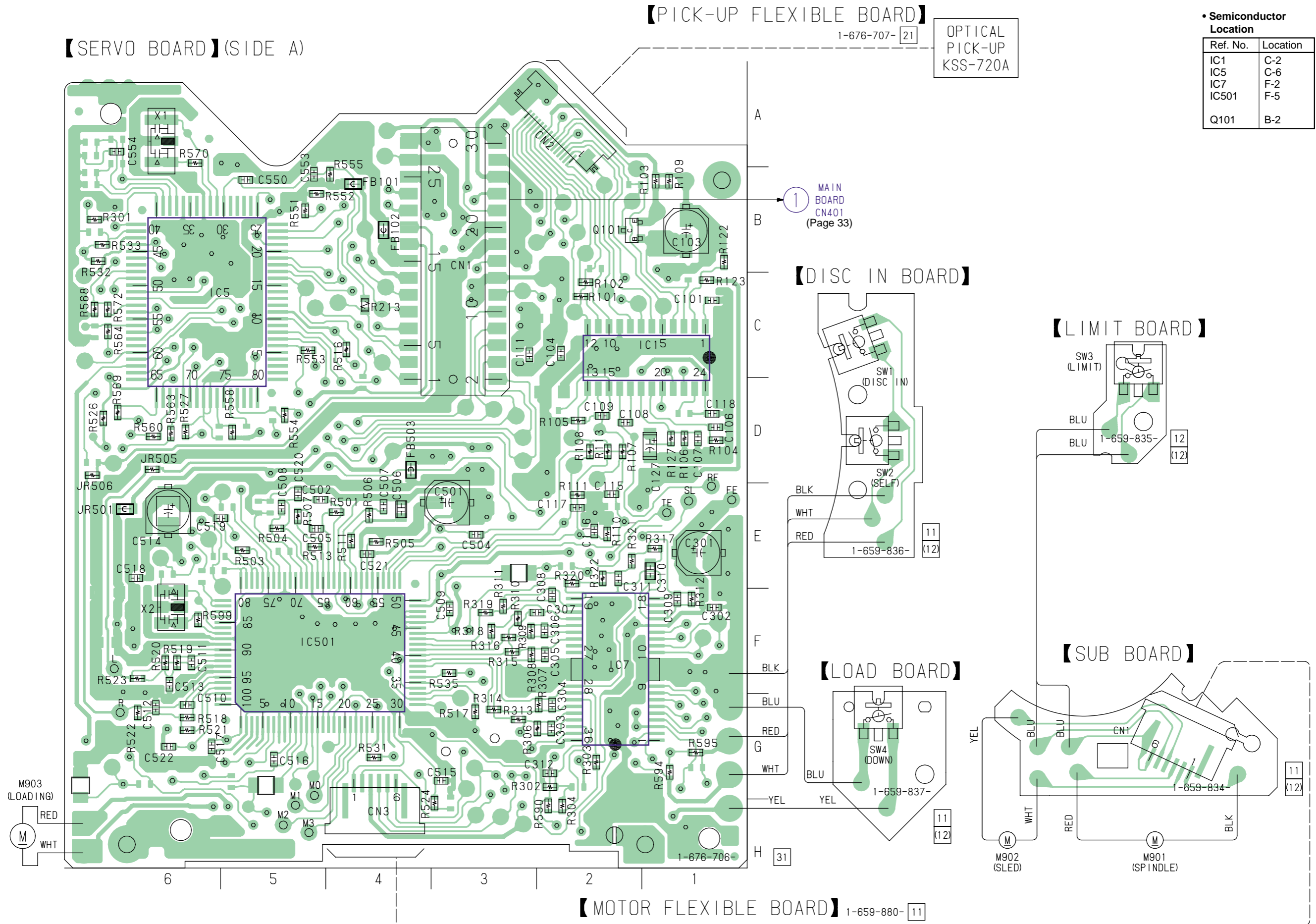

• Refer to page 27 for Waveforms.

3-7. SCHEMATIC DIAGRAM — CD MECHANISM SECTION (1/2) — • Refer to page 42 for IC Block Diagrams.

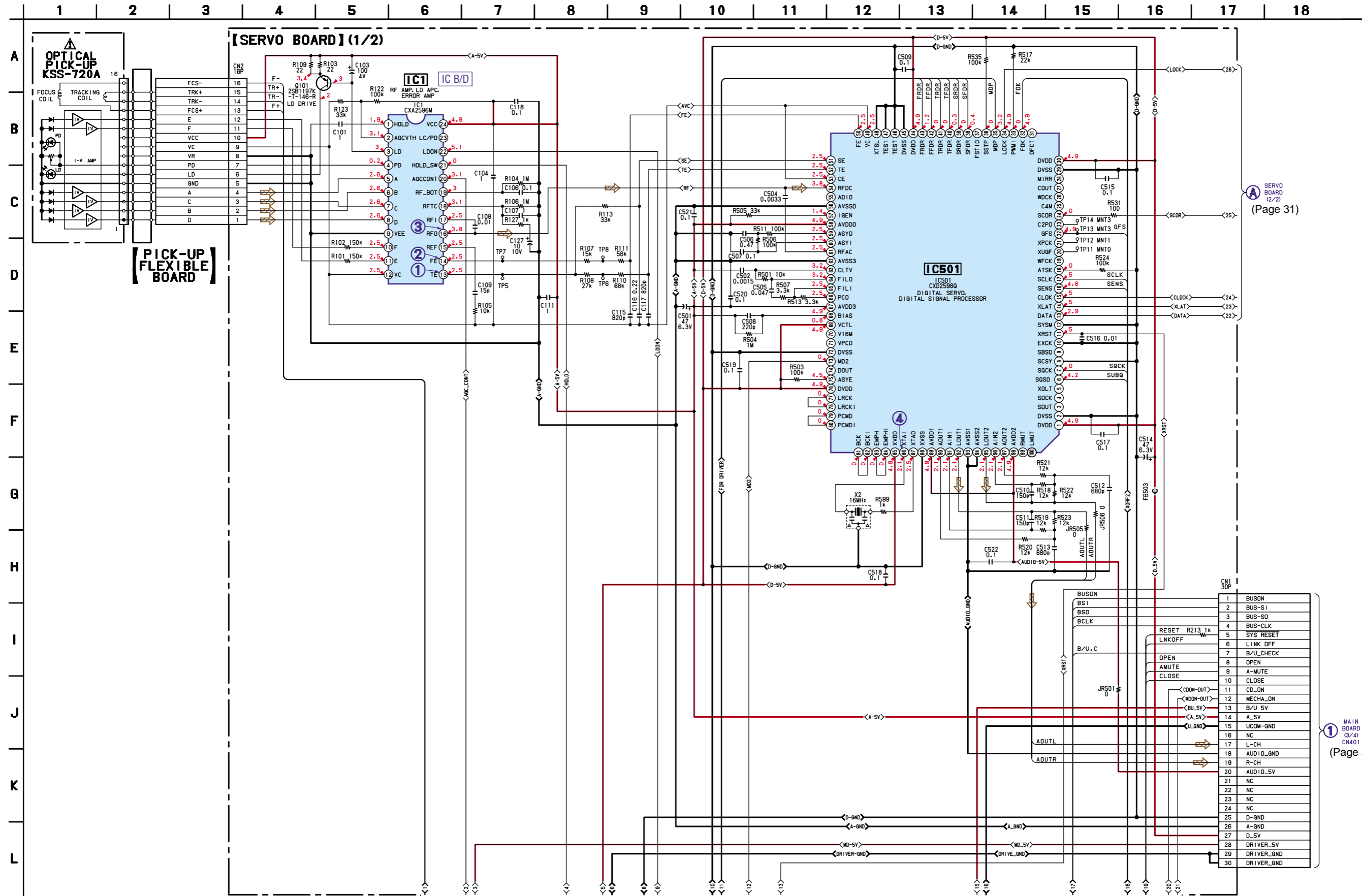

(Page 31)

(Page 36)

(Page 31)

Note:
• Voltage is dc with respect to ground under no-signal conditions.
no mark : CD PLAY

3-8. SCHEMATIC DIAGRAM — CD MECHANISM SECTION (2/2) — Refer to page 27 for Waveforms. Refer to page 42 for IC Block Diagrams.

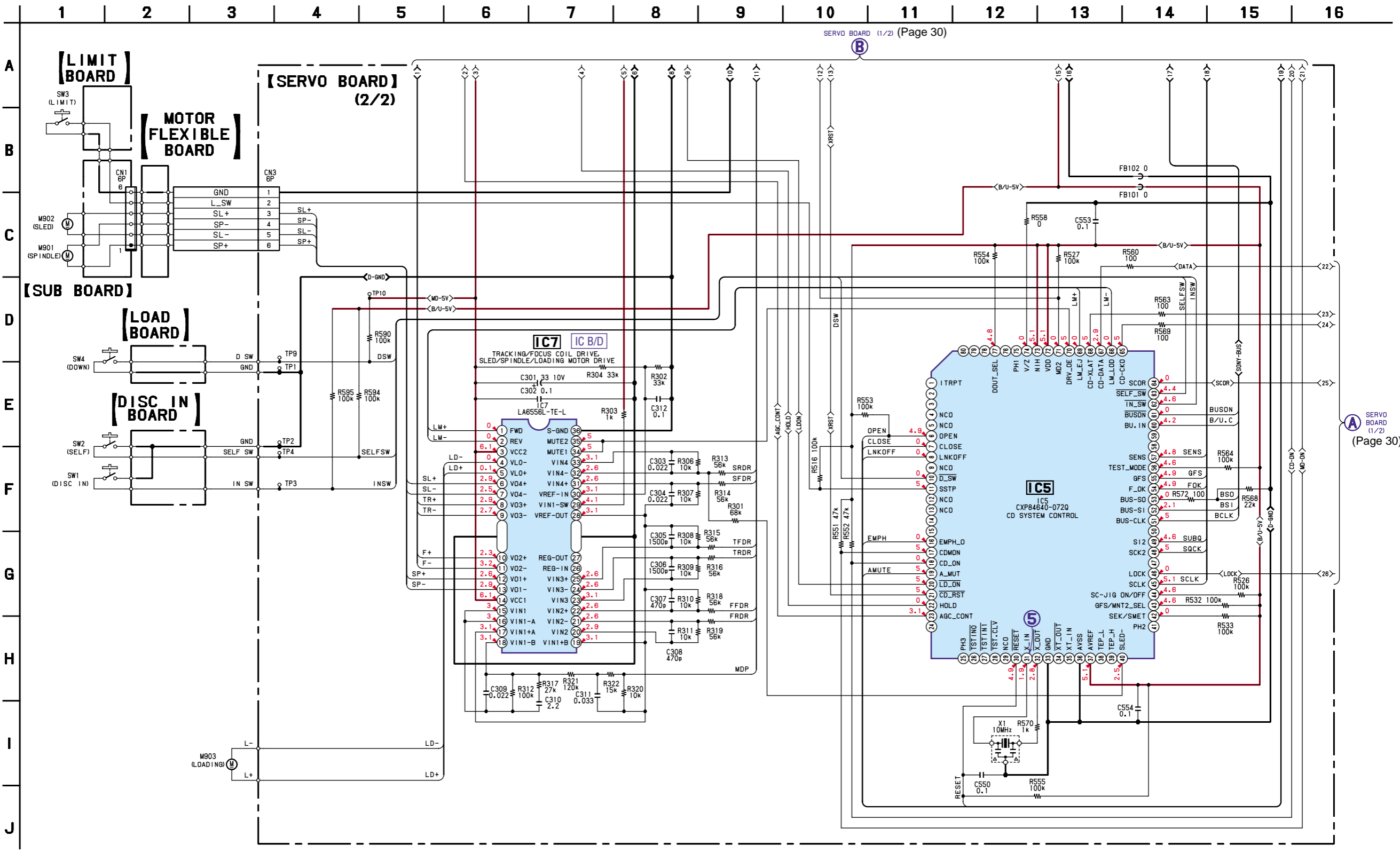

SERVO BOARD (1/2) (Page 30)

Note: Voltage is dc with respect to ground under no-signal conditions. no mark : CD PLAY

3-9. PRINTED WIRING BOARDS — MAIN SECTION —

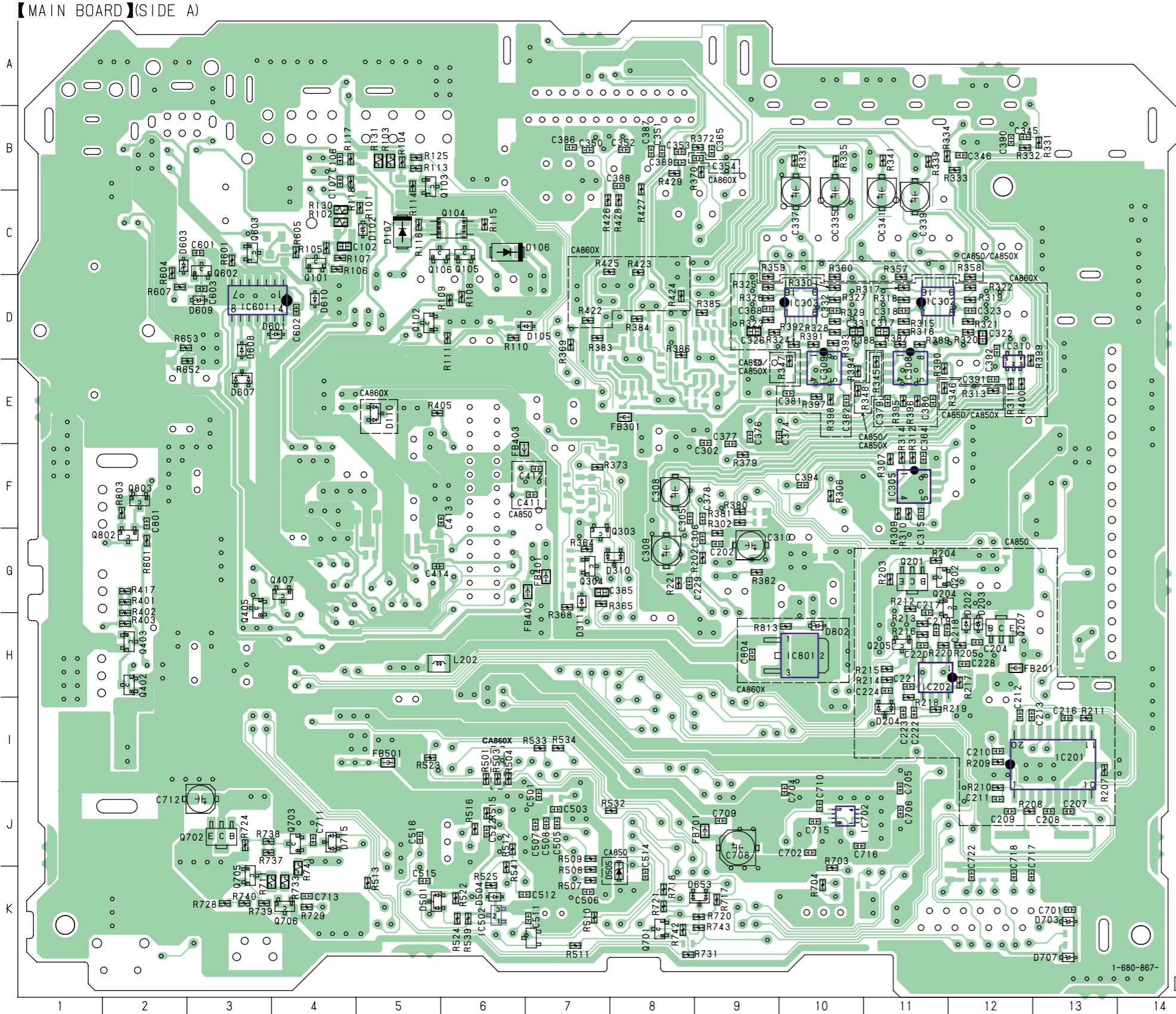

• Semiconductor Location

Ref. No.	Location	Ref. No.	Location
D102	C-5	IC310	D-12
D105	D-7	IC502	K-6
D106	C-7	IC601	D-3
D107	C-5	IC702	J-10
D110	E-5	IC801	H-10
D202	G-12		
D203	G-12	Q101	C-4
D204	I-11	Q102	D-5
D310	G-8	Q103	B-5
D311	H-7	Q104	C-6
D501	K-5	Q105	C-6
D504	K-6	Q106	C-5
D505	K-7	Q201	G-11
D601	D-4	Q202	G-12
D603	C-2	Q204	G-11
D607	E-3	Q205	H-11
D608	D-3	Q207	H-12
D609	D-3	Q303	G-8
D610	D-4	Q304	G-7
D653	K-9	Q402	H-2
D703	K-13	Q403	H-2
D707	K-13	Q405	G-3
D715	J-4	Q407	G-4
D802	H-10	Q602	C-3
		Q603	C-3
IC201	I-13	Q701	K-8
IC202	H-11	Q702	J-3
IC302	D-11	Q703	J-4
IC303	D-10	Q705	K-3
IC305	F-11	Q706	K-4
IC308	E-11	Q802	G-2
IC309	E-10	Q803	F-2

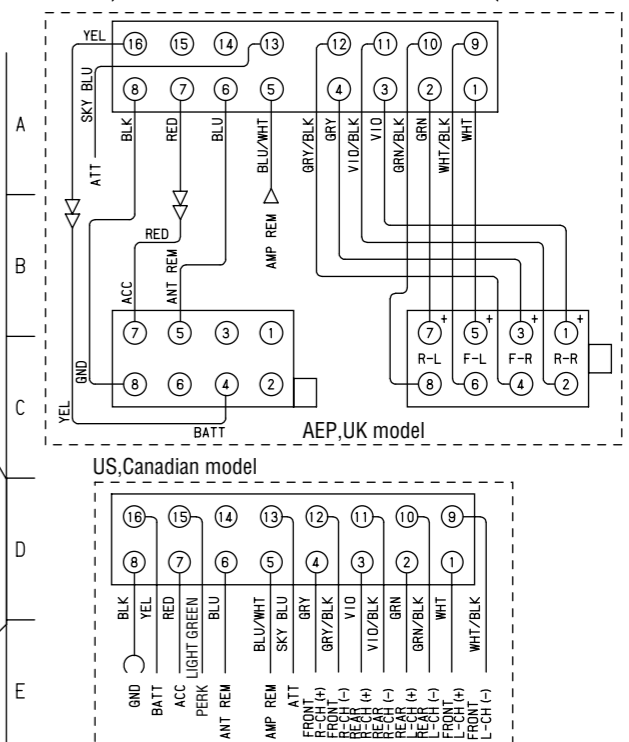
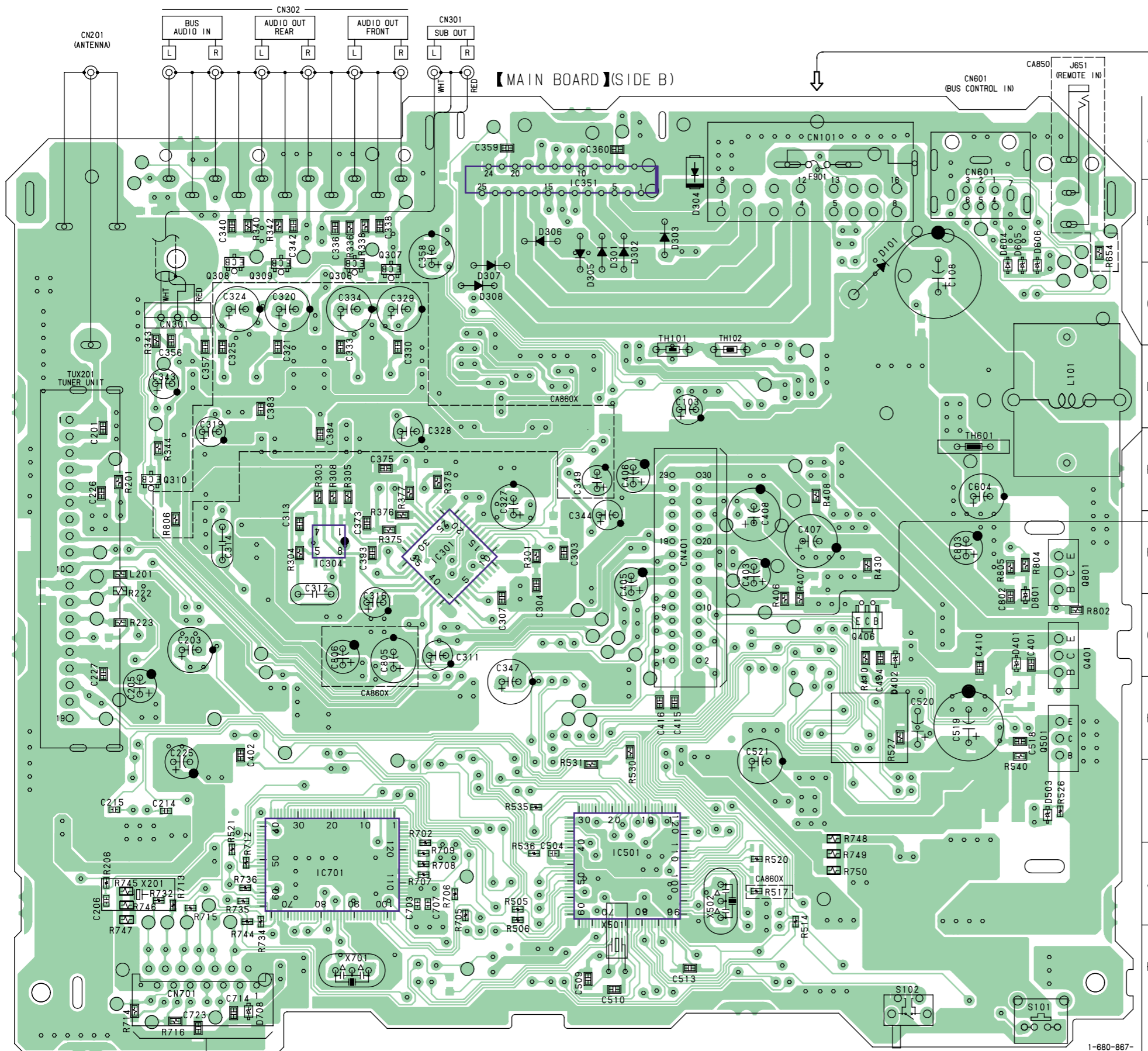

SERVO BOARD CN1 (Page 29)

Semiconductor Location	
Ref. No.	Location
D101	B-4
D301	B-7
D302	B-7
D303	B-6
D304	B-6
D305	C-7
D306	B-8
D307	C-8
D308	C-8
D401	G-2
D402	H-3
D503	I-2
D604	B-2
D605	B-2
D606	B-2
D708	K-11
D801	G-2
IC301	F-9
IC304	F-10
IC351	B-7
IC501	J-7
IC701	J-10
Q306	C-10
Q307	B-10
Q308	C-12
Q309	C-11
Q310	E-12
Q401	G-1
Q406	G-4
Q501	H-2
Q801	F-1

SUB (CD) BOARD CN851 (Page 38)

• Refer to page 27 for Waveforms.

3-10. SCHEMATIC DIAGRAM — MAIN SECTION (1/4) — • Refer to page 42 for IC Block Diagrams.

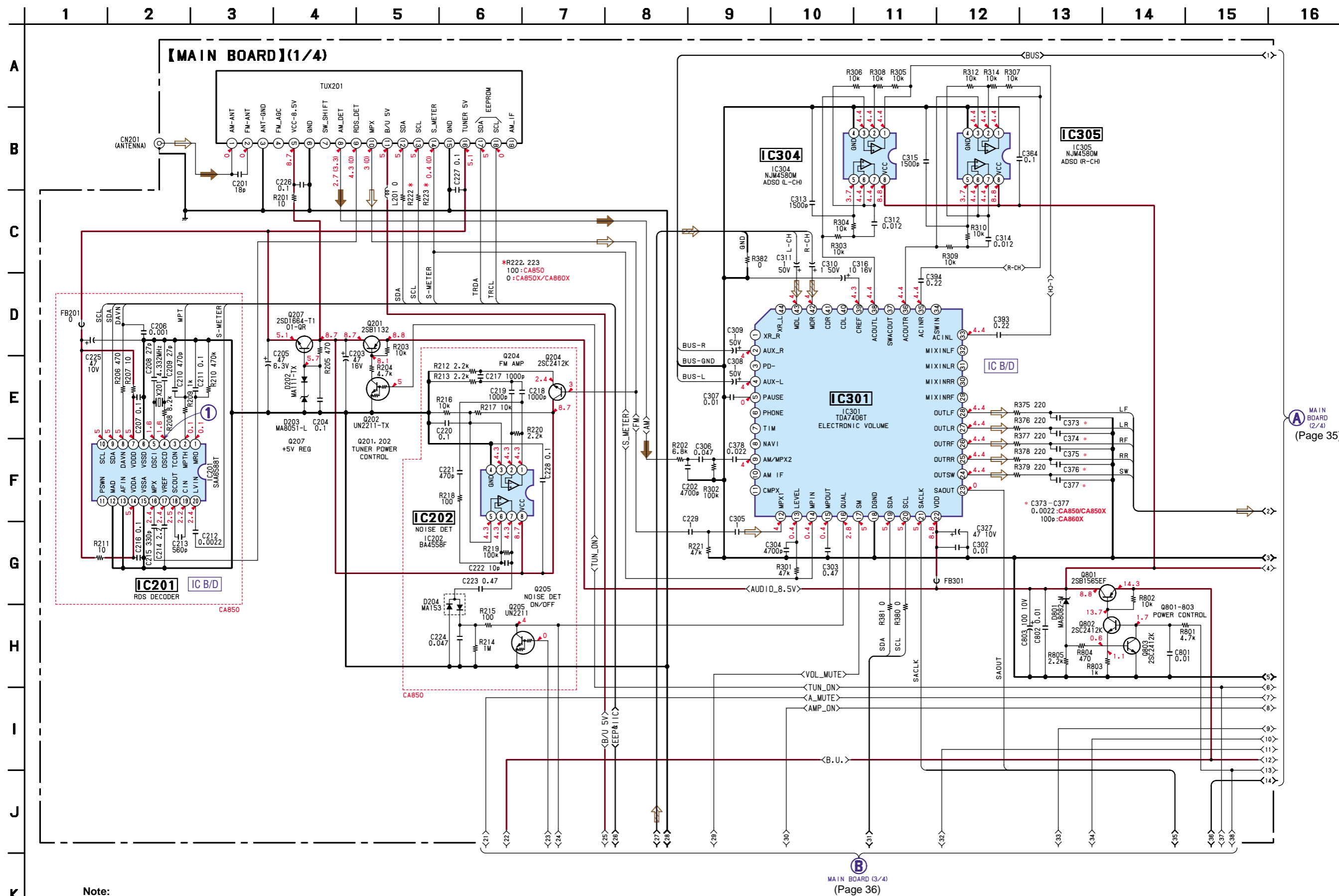

MAIN BOARD (2/4) (Page 35)

MAIN BOARD (3/4) (Page 36)

Note:
 • Voltage is dc with respect to ground under no-signal (detuned) condition.
 no mark : FM

3-11. SCHEMATIC DIAGRAM — MAIN SECTION (2/4) — • Refer to page 43 for IC Block Diagrams.

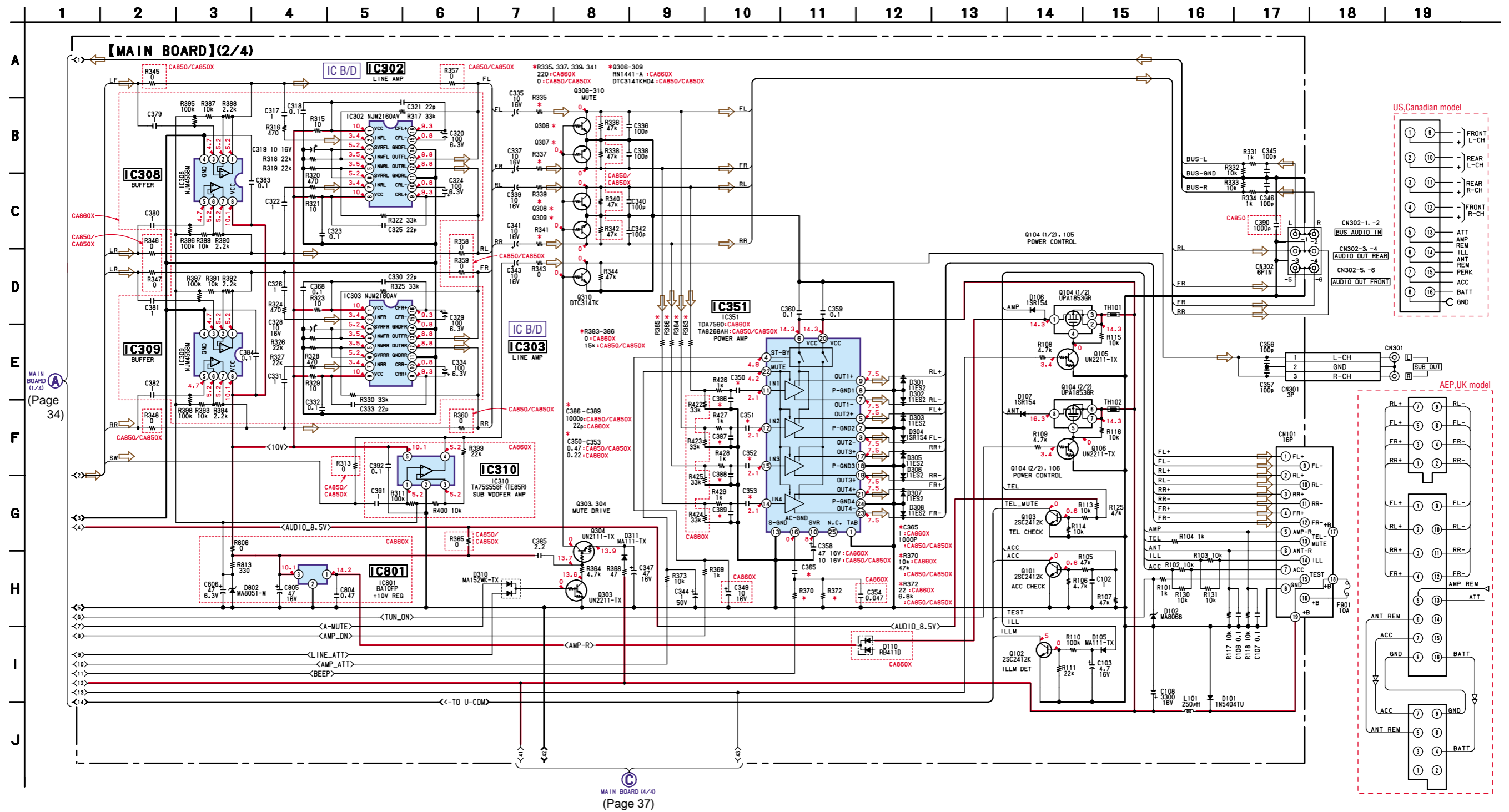

MAIN BOARD (1/4)
(Page 34)

MAIN BOARD (2/4)
(Page 37)

Note:
• Voltage is dc with respect to ground under no-signal (detuned) condition.
no mark : FM

• Refer to page 27 for Waveforms.

3-12. SCHEMATIC DIAGRAM — MAIN SECTION (3/4) — • Refer to page 42 for IC Block Diagrams.

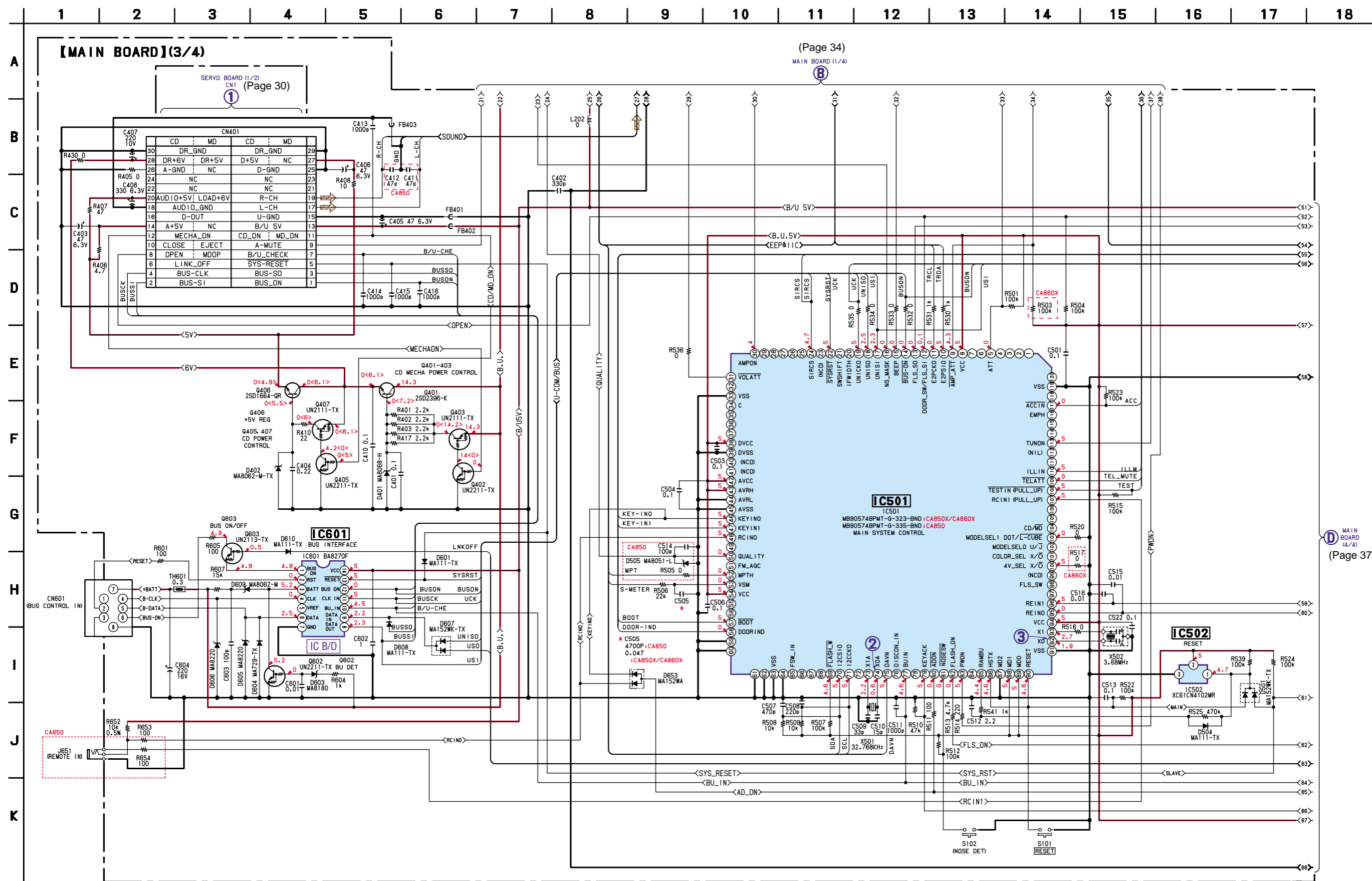

MAIN BOARD (4/4) (Page 37)

3-13. SCHEMATIC DIAGRAM — MAIN SECTION (4/4) — • Refer to page 27 for Waveforms.

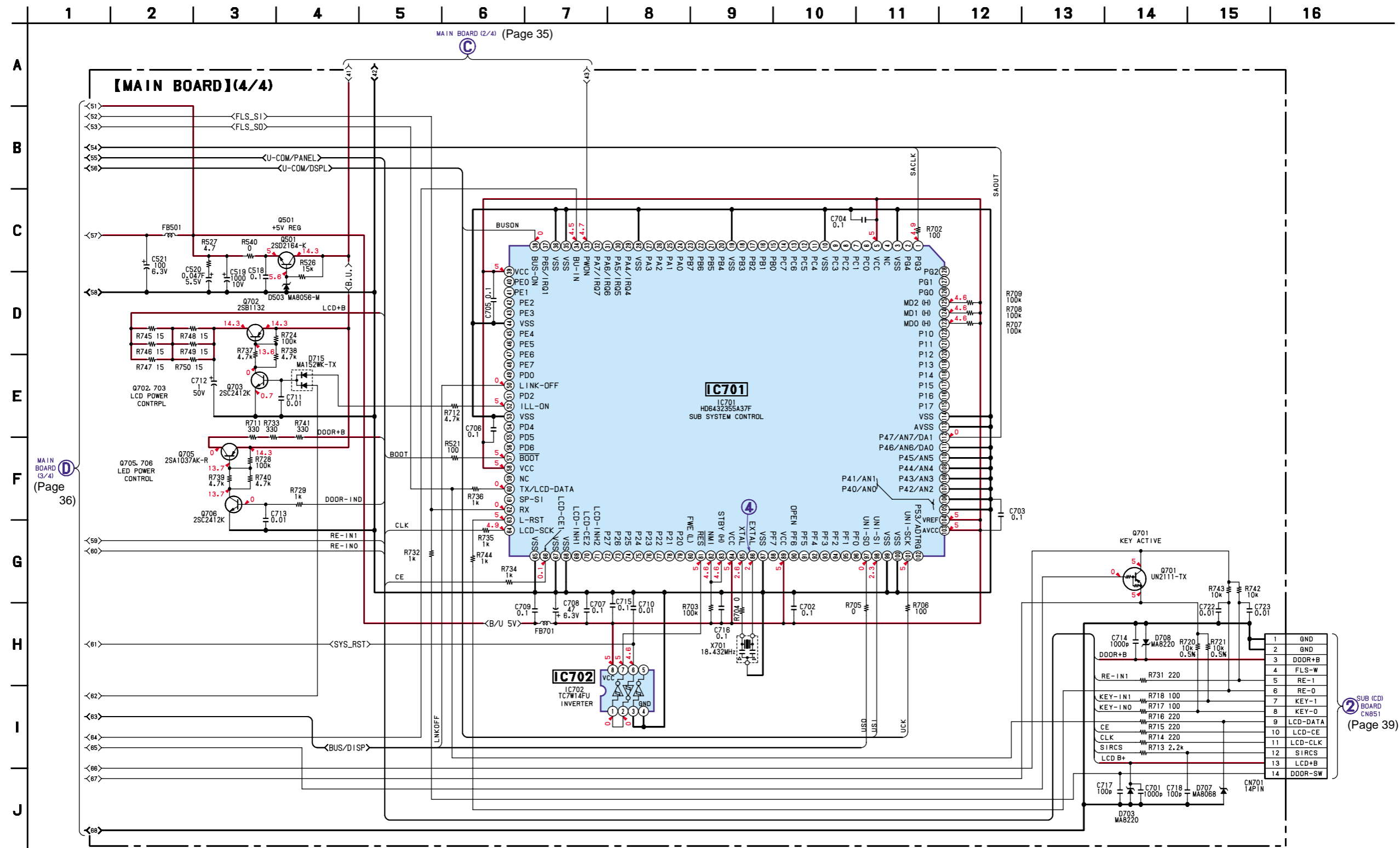

Note:
 • Voltage is dc with respect to ground under no-signal (detuned) condition.
 no mark : FM

3-14. PRINTED WIRING BOARD — SUB (CD) SECTION —

【SUB (CD) BOARD】(SIDE A)

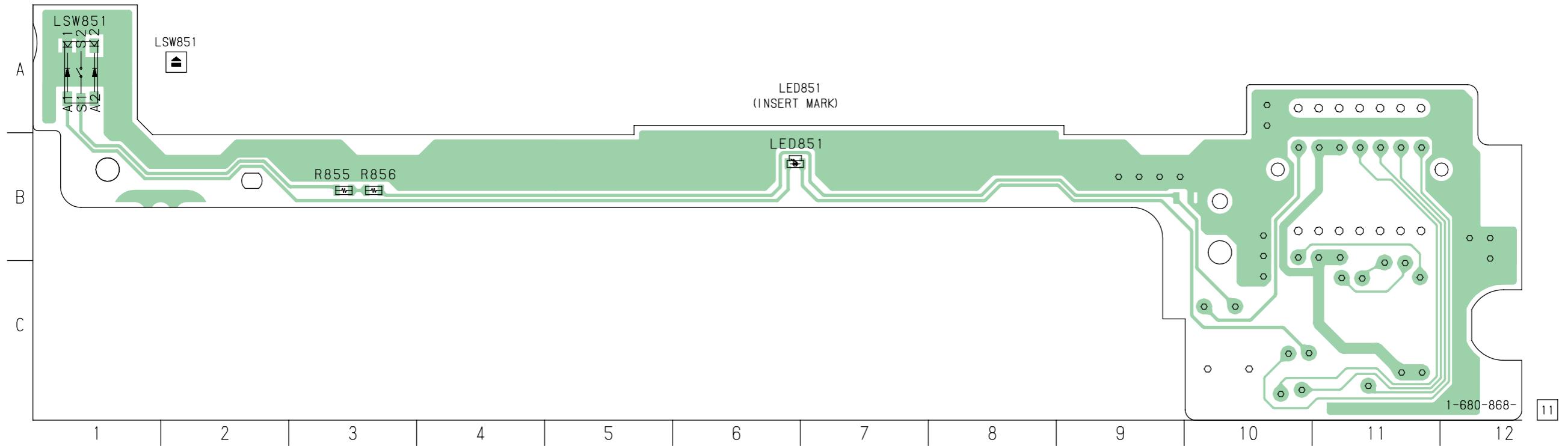

MAIN BOARD
CN701 (Page 33)

2

【SUB (CD) BOARD】(SIDE B)

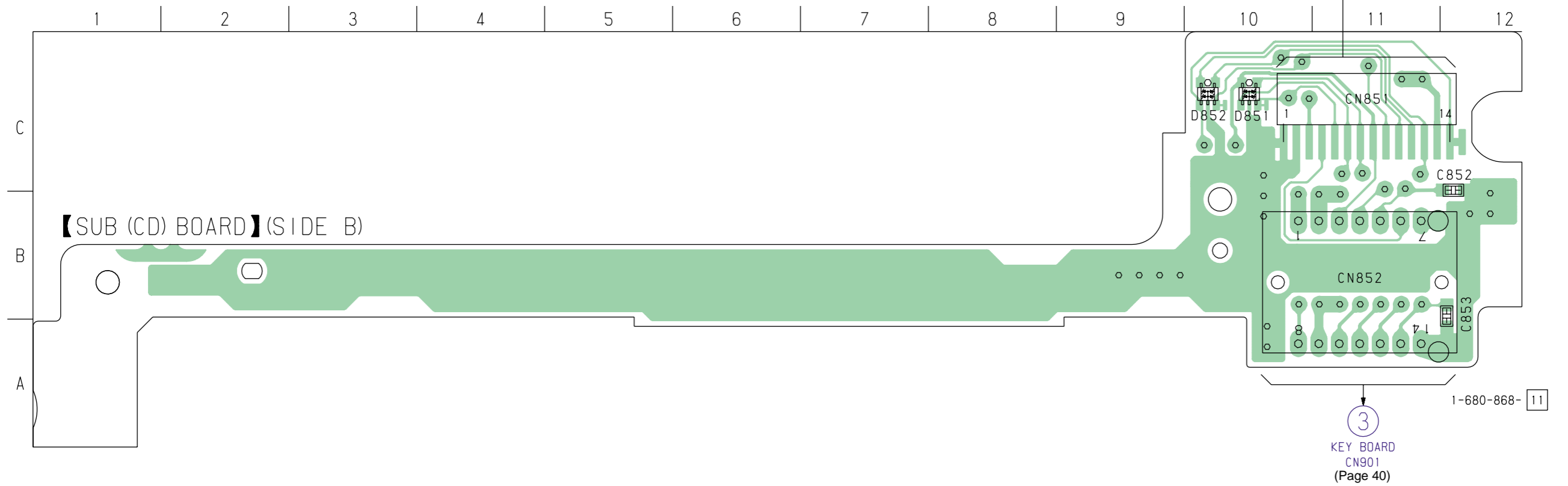

3
KEY BOARD
CN901
(Page 40)

3-15. SCHEMATIC DIAGRAM — SUB (CD) SECTION —

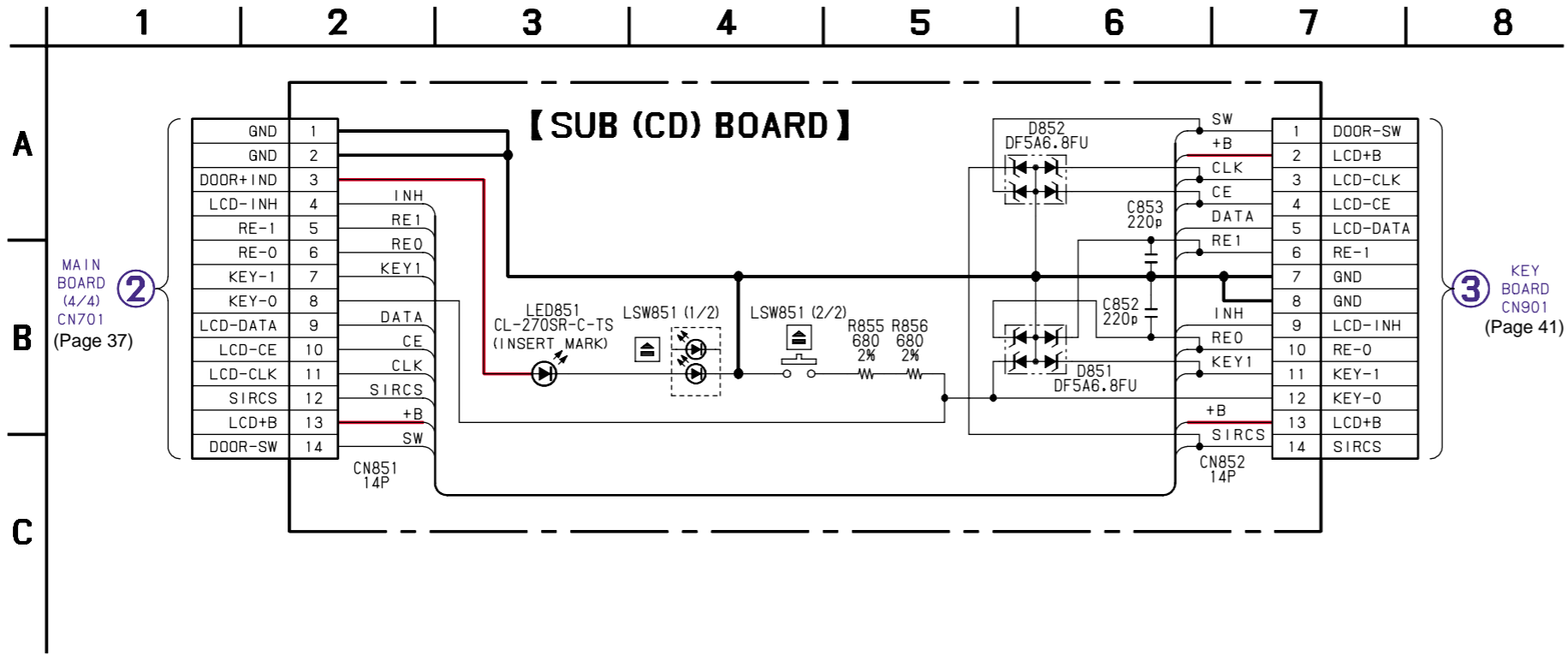

3-16. PRINTED WIRING BOARD — KEY SECTION —

【KEY BOARD】(SIDE A)

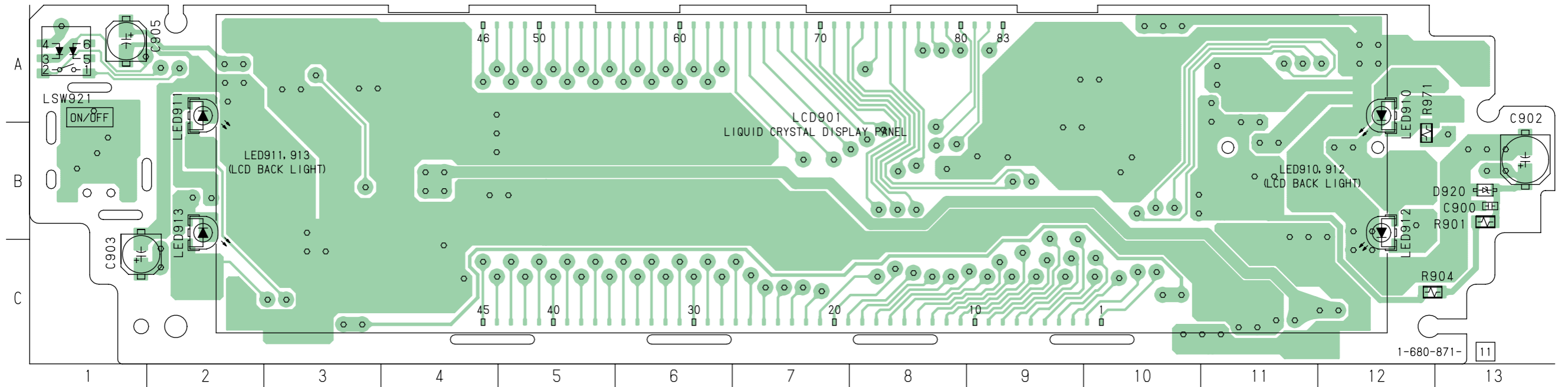

【KEY BOARD】(SIDE B)

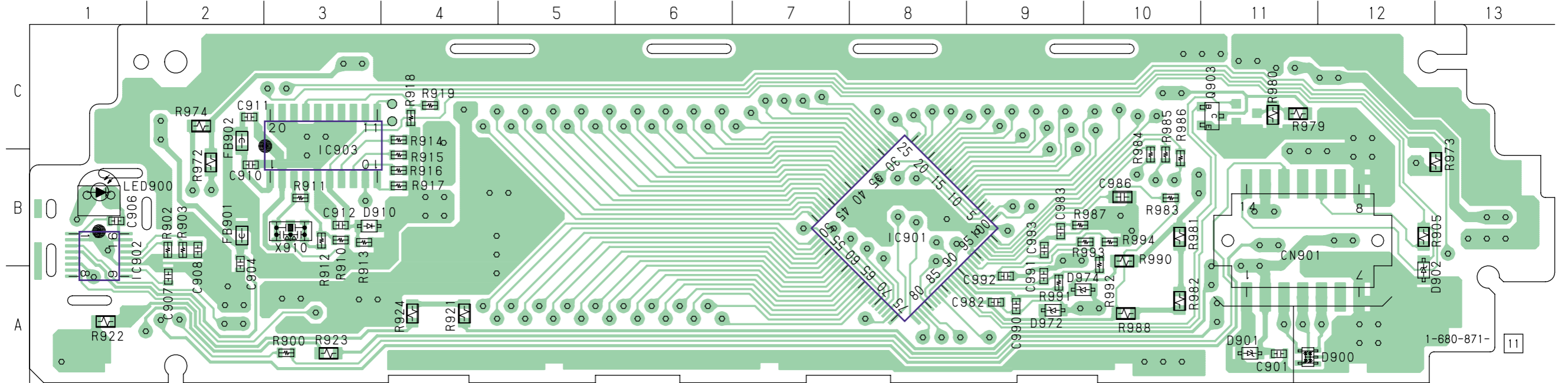

• Semiconductor Location

Ref. No.	Location	Ref. No.	Location
(D900)	A-12	(IC903)	B-3
(D901)	A-11	(LED900)	B-1
(D902)	B-12	LED910	B-12
(D910)	B-3	LED911	B-2
D920	B-13	LED912	B-12
(D972)	A-9	LED913	B-2
(D974)	A-9		
(IC901)	B-8	(Q903)	C-11
(IC902)	B-1		

() : SIDE B

③
SUB (CD) BOARD
CN852
(Page 38)

• Refer to page 27 for Waveforms.

3-17. SCHEMATIC DIAGRAM — KEY SECTION — • Refer to page 43 for IC Block Diagrams.

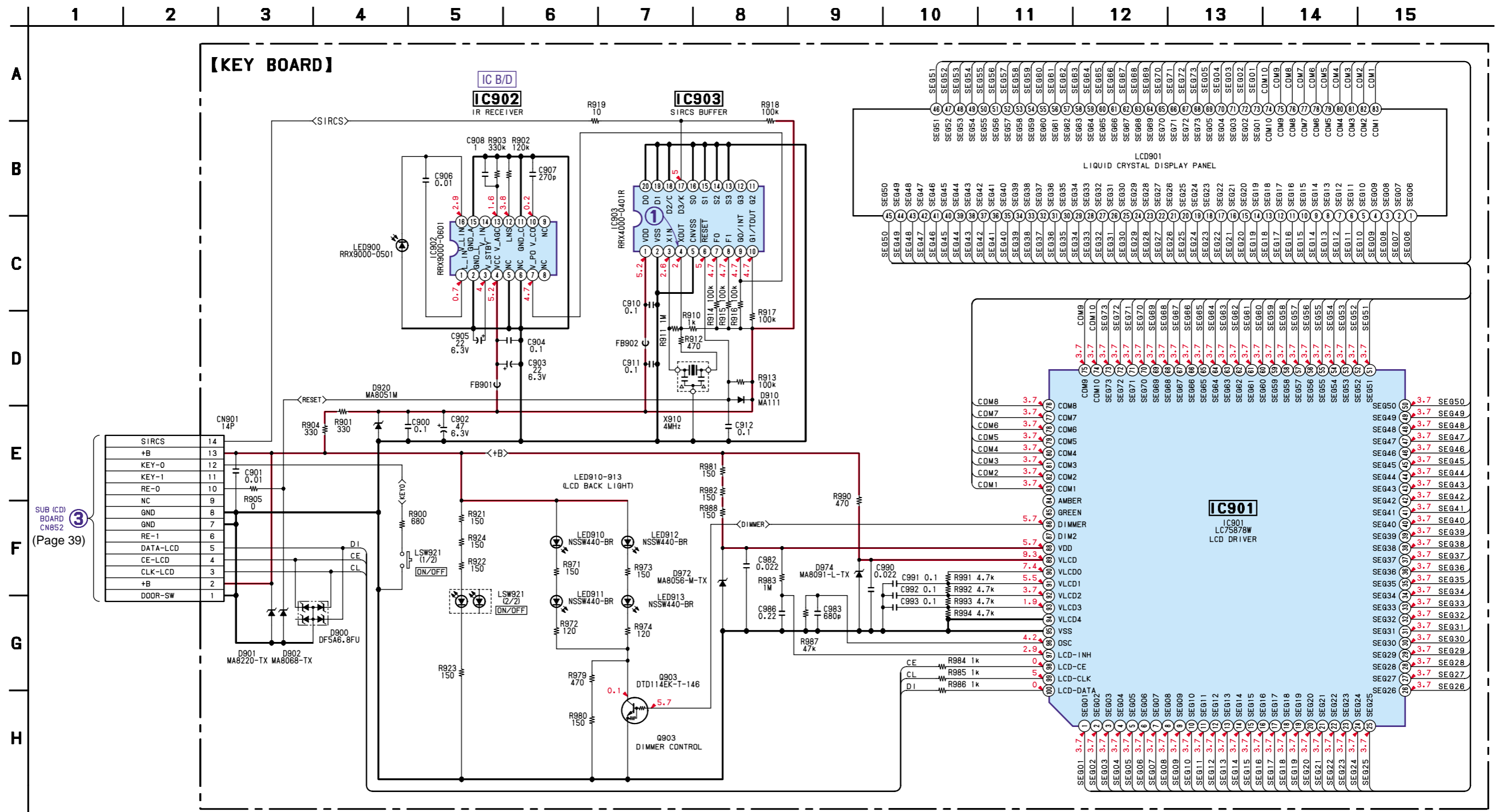

Note:
 • Voltage is dc with respect to ground under no-signal (detuned) condition.
 no mark : FM

• IC BLOCK DIAGRAMS

IC1 CXA2596M

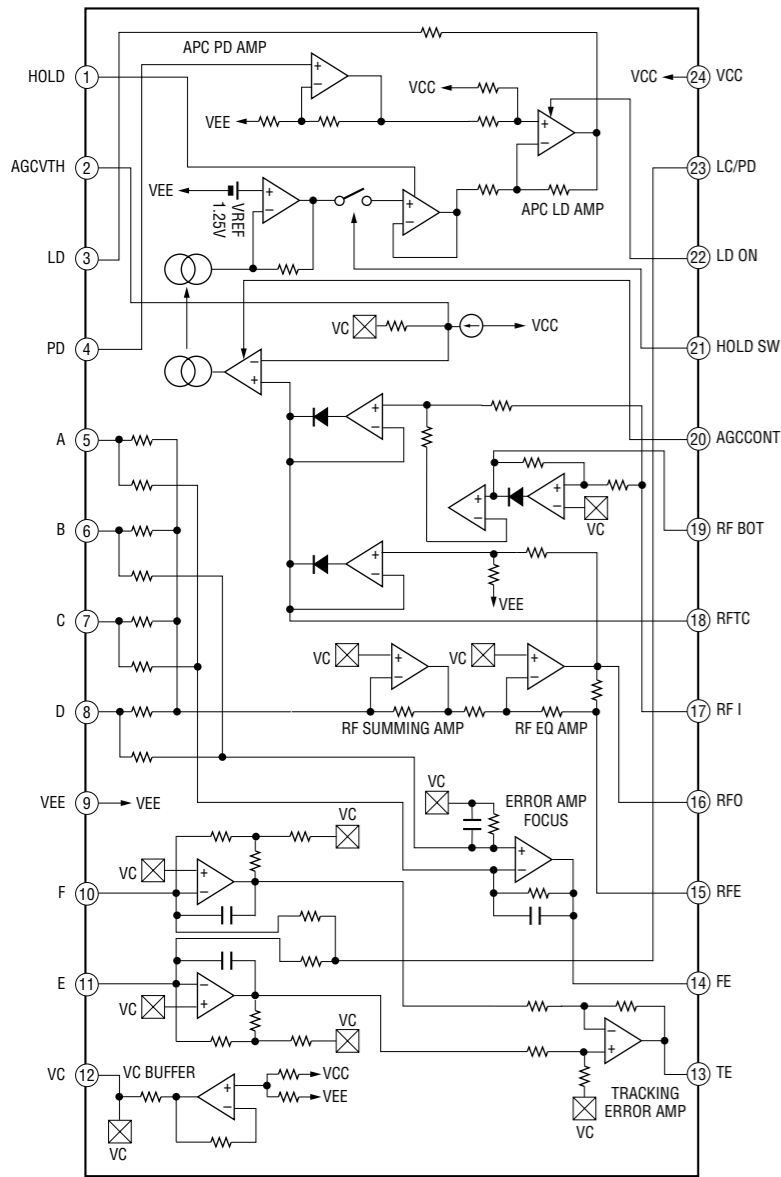

IC601 BA8270F

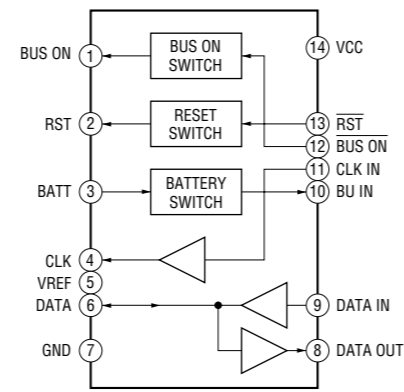

IC7 LA6556L-TE-L

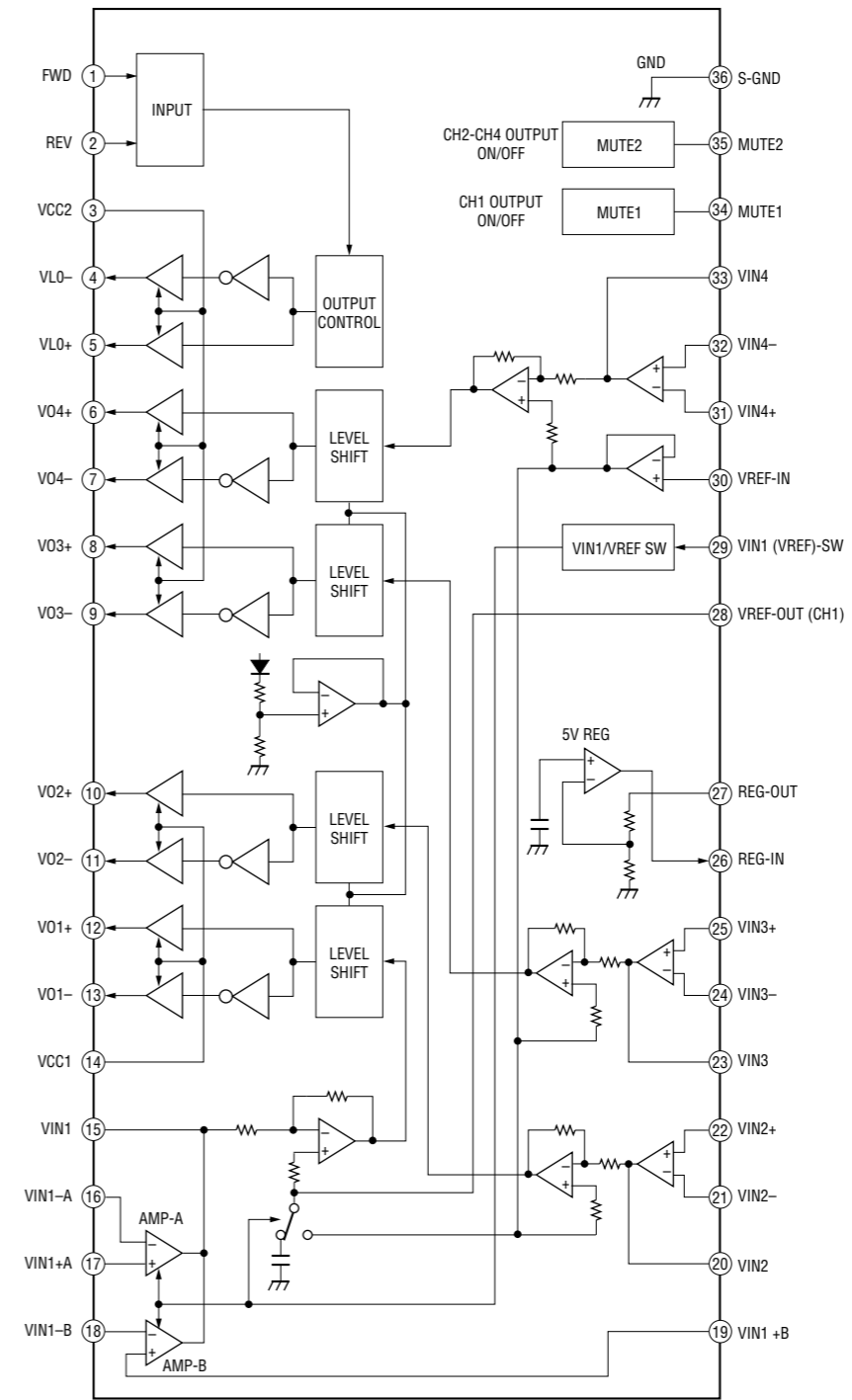

IC201 SAA6588T

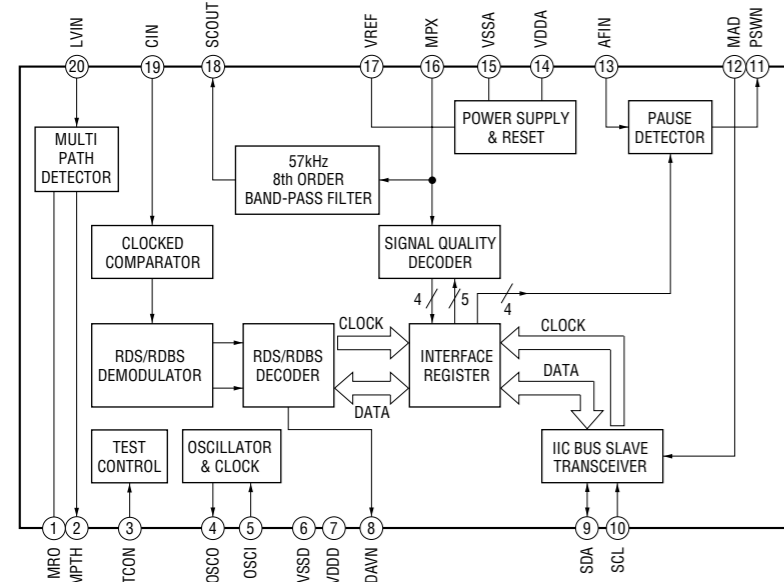

IC301 TDA7406T

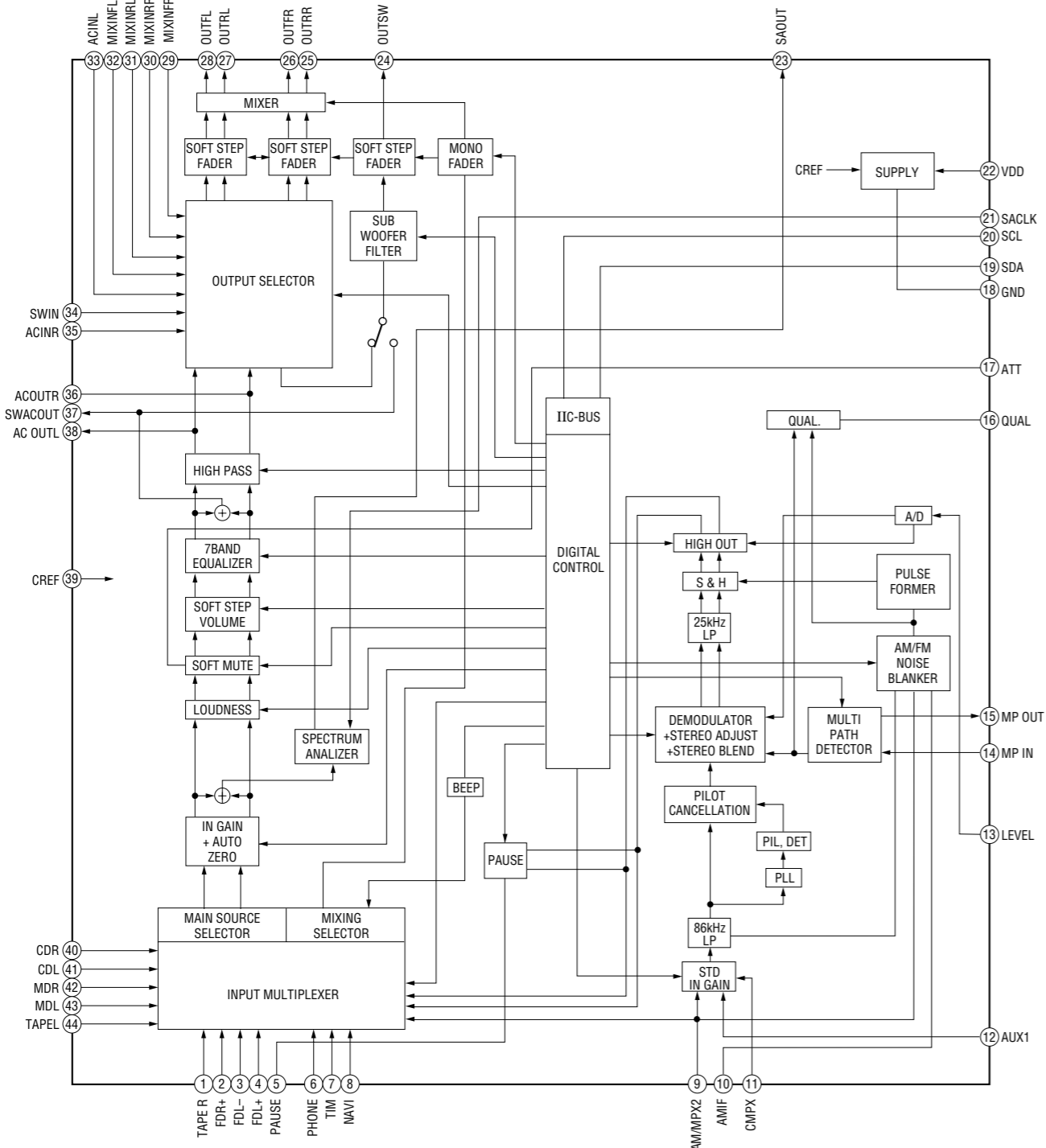

IC302, 303 NJM2160AV

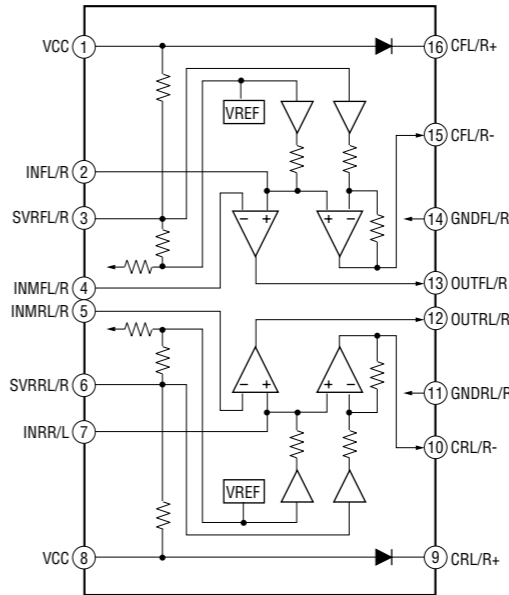

IC902 RRX9000-0601

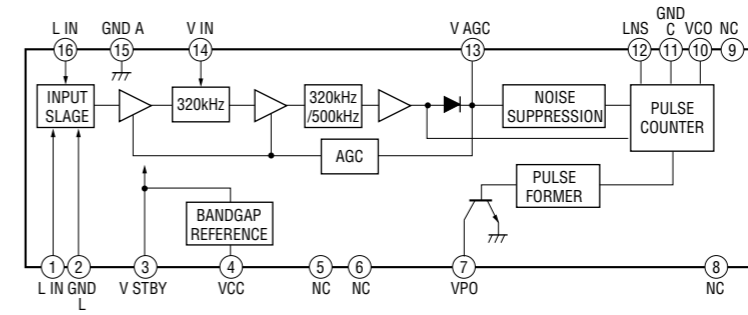

SECTION 4 EXPLODED VIEWS

NOTE:

- The mechanical parts with no reference number in the exploded views are not supplied.
- Items marked "*" are not stocked since they are seldom required for routine service. Some delay should be anticipated when ordering these items.
- -XX and -X mean standardized parts, so they may have some difference from the original one.

- Color Indication of Appearance Parts
Example :
KNOB, BALANCE (WHITE) ... (RED)
↑ ↑
Parts Color Cabinet's Color
- Accessories and packing materials and hardware (# mark) list are given in the last of this parts list.

The components identified by mark Δ or dotted line with mark Δ are critical for safety. Replace only with part number specified.

Les composants identifiés par une marque Δ sont critiques pour la sécurité. Ne les remplacer que par une pièce portant le numéro spécifié.

4-1. CHASSIS SECTION

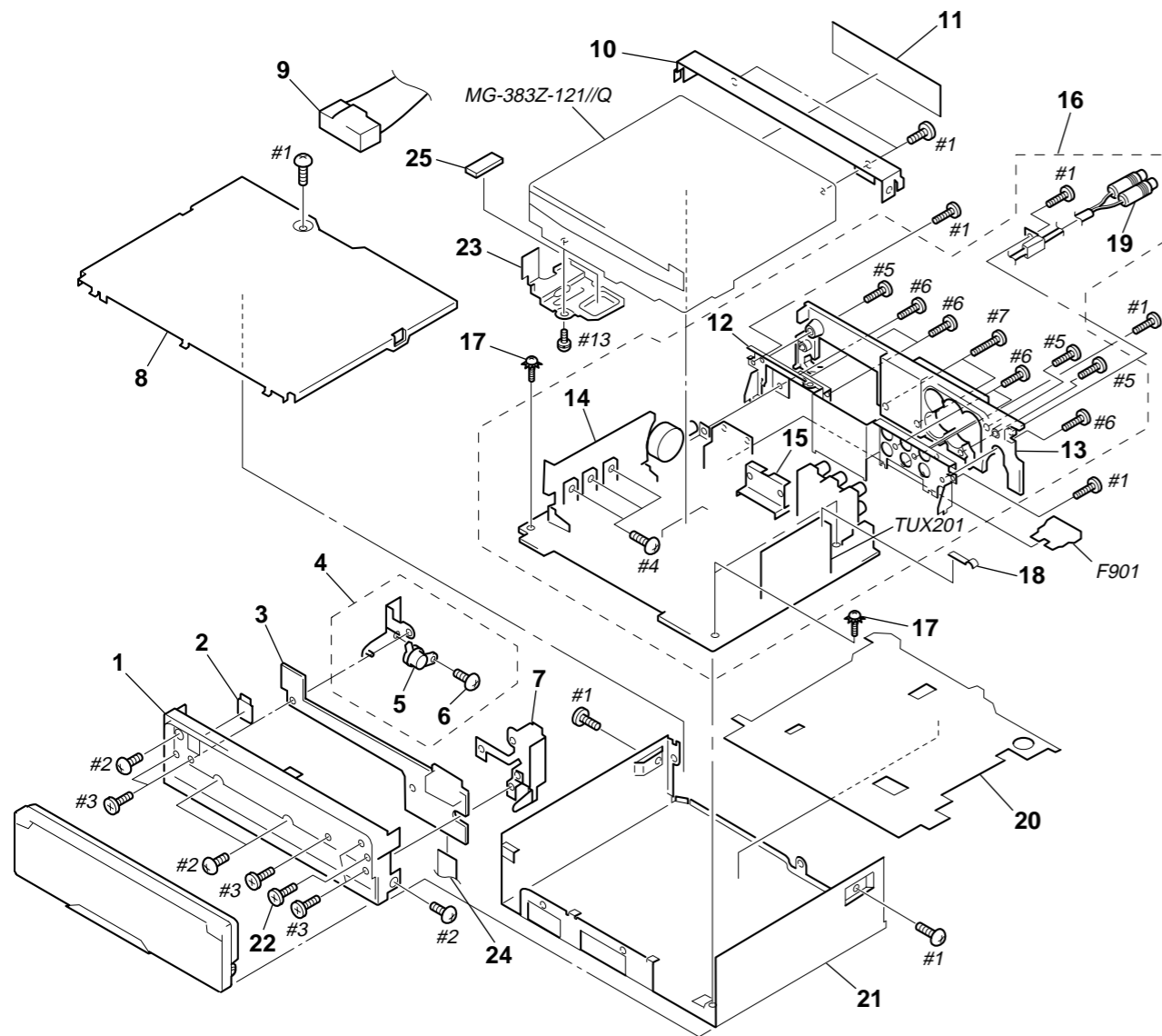

Ref. No.	Part No.	Description	Remark	Ref. No.	Part No.	Description	Remark
1	X-3378-512-1	PANEL ASSY, SUB		* 15	3-040-998-01	BRACKET (IC)	
2	3-040-990-01	BUTTON (EJECT)		* 16	A-3283-144-A	MAIN BOARD, COMPLETE (CA850)	
* 3	1-680-868-11	SUB (CD) BOARD		* 16	A-3283-145-A	MAIN BOARD, COMPLETE (CA860X)	
4	X-3376-699-1	GEAR ASSY		* 16	A-3283-146-A	MAIN BOARD, COMPLETE (CA850X)	
5	3-030-909-01	DAMPER, OIL		17	3-376-464-11	SCREW (+PTT 2.6X6), GROUND POINT	
6	3-713-786-51	SCREW +P 2X3		* 18	3-045-878-01	PLATE (TU), GROUND	
7	X-3377-621-1	LOCK ASSY		19	1-790-355-51	CORD (WITH CONNECTOR) (RCA) (SUB OUT (MONO))	
* 8	3-223-782-01	COVER		* 20	3-224-755-01	SHEET, INSULATING	
9	1-776-207-72	CORD (WITH CONNECTOR) (POWER)		* 21	3-223-781-01	CHASSIS	
9	1-776-527-71	CORD (WITH CONNECTOR) (ISO) (POWER)	(CA850X/CA860X) (CA850)	22	3-047-812-01	SCREW (LOCK)	
* 10	3-041-012-01	BRACKET (CD)		* 23	3-045-857-01	HEAT SINK (CD)	
* 11	3-227-287-01	SHEET, DUST PROTECTION		24	1-792-195-11	CABLE, FLEXIBLE FLAT (14 CORE)	
* 12	3-223-783-21	CHASSIS (BACK)		25	3-046-626-01	SHEET, RADIATION	
* 13	3-223-780-01	HEAT SINK (CA850)		F901	1-532-877-11	FUSE (BLADE TYPE) (AUTO FUSE) 10A	
* 13	3-223-780-21	HEAT SINK (CA850X/CA860X)		TUX201	A-3220-812-A	TUNER UNIT (TUX-020)	
* 14	3-223-785-01	HEAT SINK (REG/D)					

4-2. FRONT PANEL SECTION

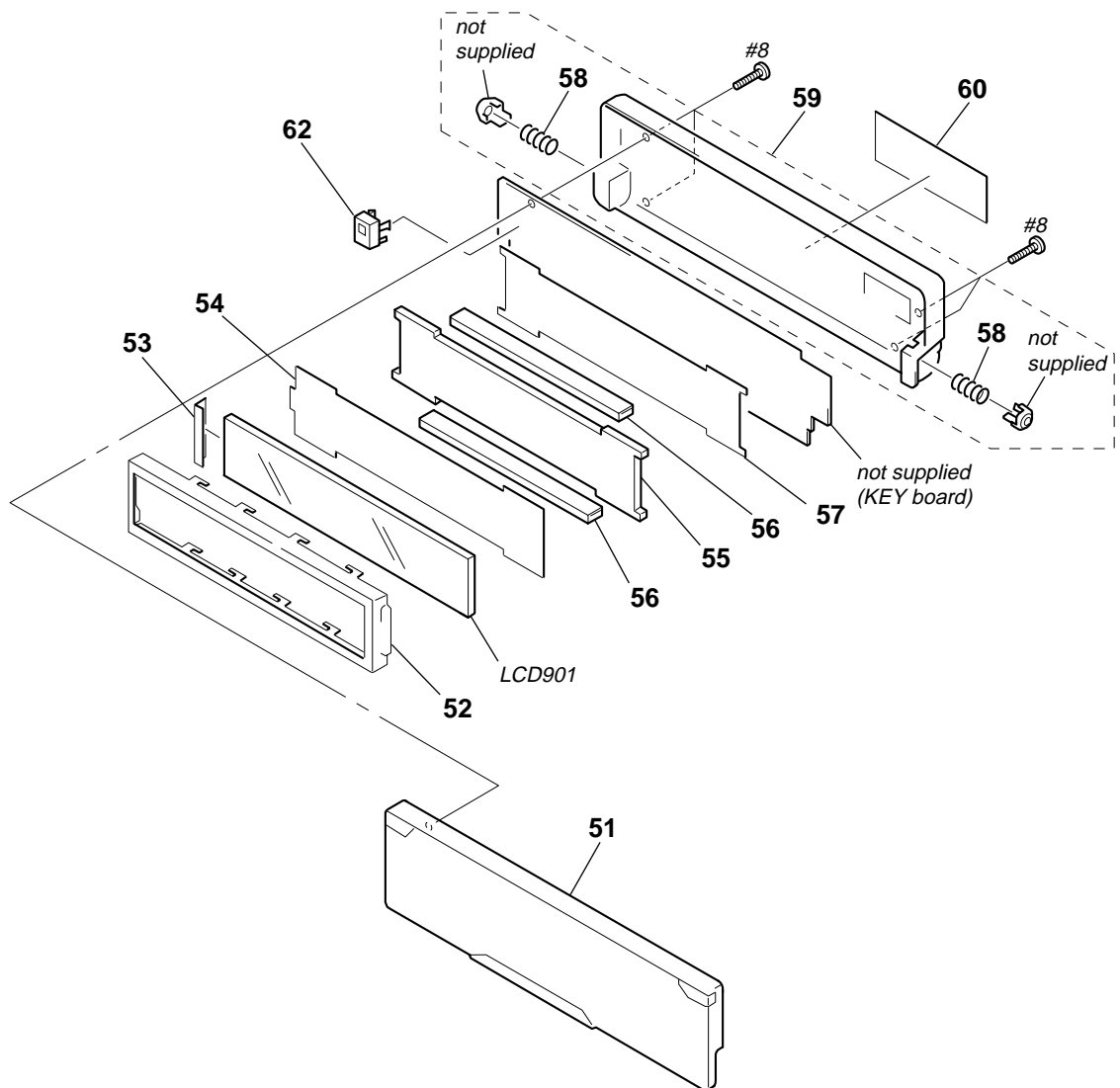

Ref. No.	Part No.	Description	Remark	Ref. No.	Part No.	Description	Remark
51	X-3380-575-1	PANEL ASSY, FRONT		58	3-031-319-01	SPRING (BEARING)	
* 52	3-227-279-01	PLATE (LCD), GROUND		59	X-3380-118-1	PANEL ASSY, FRONT BACK	
* 53	3-230-625-01	SHEET		60	3-227-286-01	PLATE (FBP), ORNAMENTAL (CA850)	
* 54	3-227-283-01	SHEET (ILLUMINATOR)		60	3-227-286-11	PLATE (FBP), ORNAMENTAL (CA850X)	
* 55	3-227-278-01	PLATE (LCD), LIGHT GUIDE		60	3-227-286-21	PLATE (FBP), ORNAMENTAL (CA860X)	
56	1-694-780-11	CONDUCTIVE BOARD, CONNECTION		* 62	3-227-280-01	CASE (IR-T), SHIELD	
* 57	3-227-284-01	SHEET (REFLECTOR)		LCD901	1-804-308-11	DISPLAY PANEL, LIQUID CRYSTAL	

4-3. CD MECHANISM SECTION (1)
(MG-383Z-121//Q)

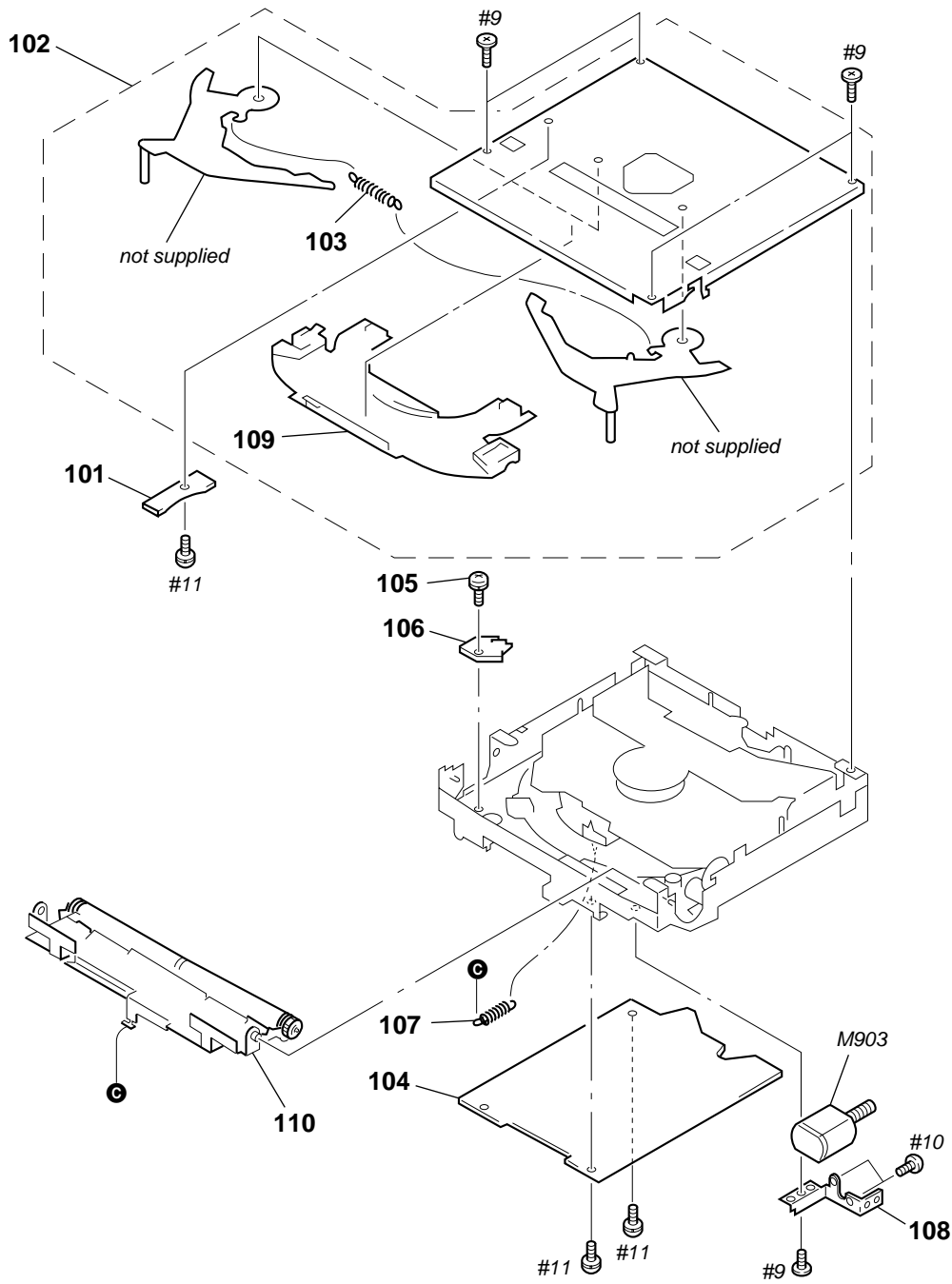

Ref. No.	Part No.	Description	Remark	Ref. No.	Part No.	Description	Remark
* 101	1-659-836-11	DISC IN BOARD		107	3-047-477-01	SPRING (RA2), TENSION COIL	
* 102	A-3315-034-E	CHASSIS (T) ASSY		* 108	3-039-629-01	BRACKET (MOTOR)	
103	3-931-909-01	SPRING (LR), TENSION		109	3-931-908-13	GUIDE (DISC)	
* 104	A-3326-231-A	SERVO BOARD, COMPLETE		110	A-3315-040-A	ROLLER ASSY, ARM	
105	3-338-737-01	SCREW (2X3), +PS		M903	A-3315-039-A	MOTOR SUB ASSY, LD (LOADING)	
* 106	1-659-837-11	LOAD BOARD					

4-4. CD MECHANISM SECTION (2)
(MG-383Z-121//Q)

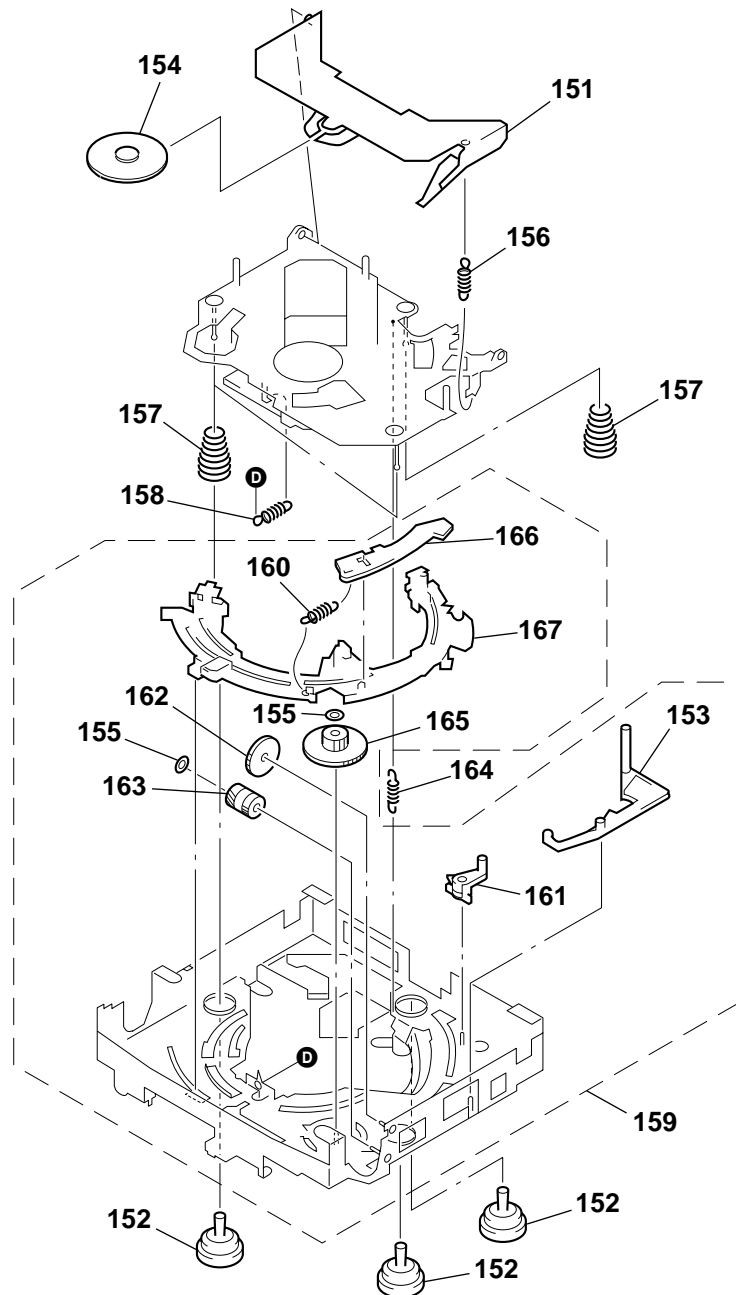

Ref. No.	Part No.	Description	Remark	Ref. No.	Part No.	Description	Remark
151	X-3378-956-1	ARM ASSY, CHUCKING		160	3-220-180-01	SPRING (TR2), TENSION	
152	3-931-897-61	DAMPER (T)		161	3-931-881-01	LEVER (LOCK)	
153	3-039-627-01	LEVER (D)		162	3-931-882-02	GEAR (MDL)	
154	3-040-165-01	RETAINER (DISC)		163	3-007-537-11	WHEEL (U), WORM	
155	3-018-272-01	WASHER		164	3-032-484-01	SPRING (KR1), TENSION	
156	3-931-895-01	SPRING (CH), TENSION		165	3-014-727-01	WHEEL (LW), WORM	
157	3-931-898-01	SPRING (FL), COMPRESSION		166	3-039-626-01	LEVER (TR)	
158	3-032-483-01	SPRING (KF1), TENSION		167	3-025-418-22	RING, LOADING	
159	A-3307-471-C	OVERALL ASSY, CHASSIS (M)					

4-5. CD MECHANISM SECTION (3)
(MG-383Z-121//Q)

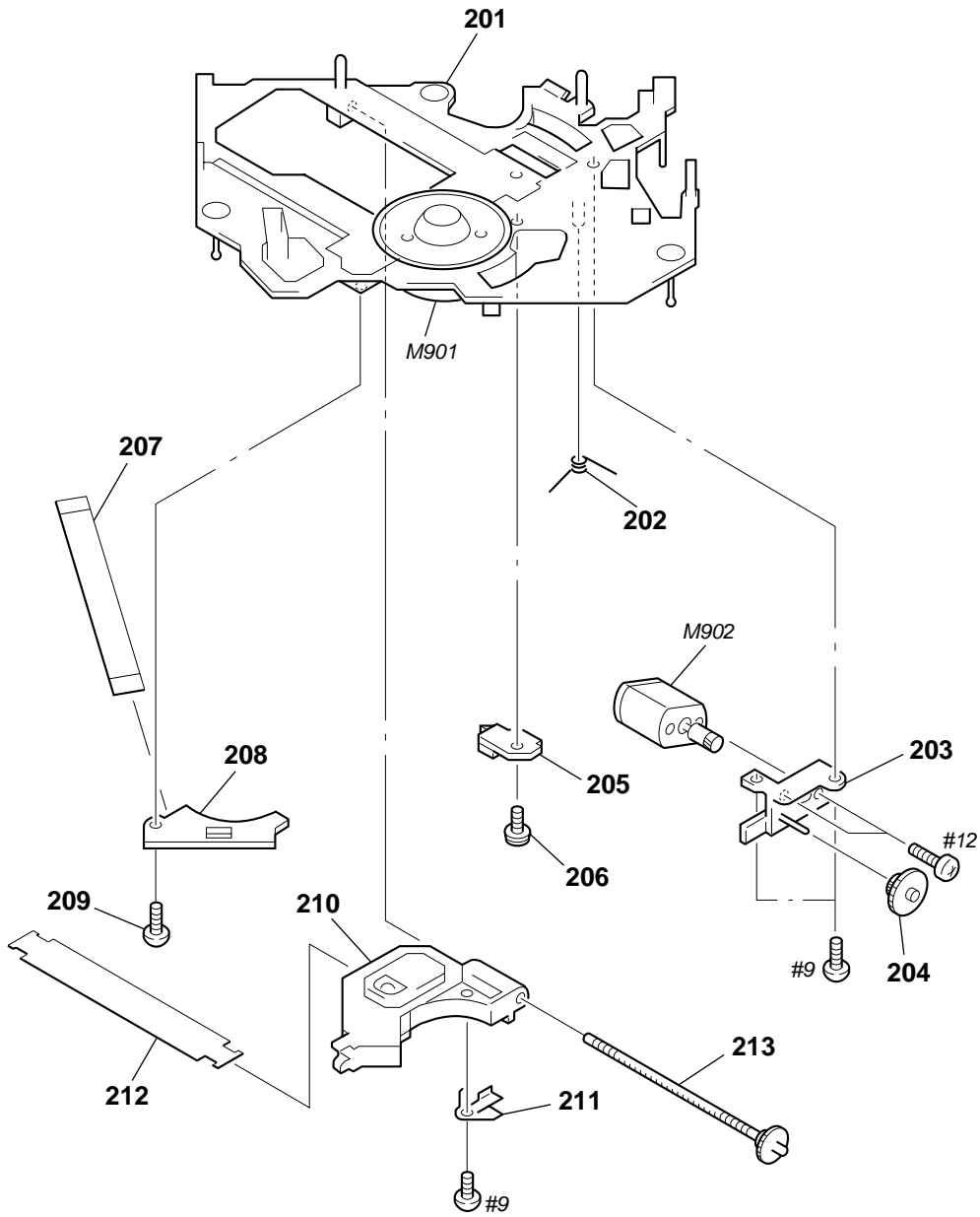

<p>The components identified by mark \triangle or dotted line with mark \triangle are critical for safety. Replace only with part number specified.</p>	<p>Les composants identifiés par une marque \triangle sont critiques pour la sécurité. Ne les remplacer que par une pièce portant le numéro spécifié.</p>
---	--

Ref. No.	Part No.	Description	Remark	Ref. No.	Part No.	Description	Remark
201	X-3378-598-1	CHASSIS (OP) ASSY (including M901)		* 208	1-659-834-11	SUB BOARD	
202	3-043-494-01	SPRING (SL), TORSION		209	3-909-607-01	SCREW	
203	3-040-170-01	BASE (DRIVING)		\triangle 210	8-820-103-03	PICK-UP, OPTICAL KSS-720A/K1RP	
204	3-040-419-01	GEAR (MIDWAY)		211	3-025-743-01	SPRING (FEED), LEAF	
* 205	1-659-835-11	LIMIT BOARD		212	1-676-707-21	PICK-UP FLEXIBLE BOARD	
206	3-338-737-01	SCREW (2X3), +PS		213	A-3315-306-A	SHAFT (FEED) ASSY	
207	1-659-880-11	MOTOR FLEXIBLE BOARD		M902	A-3291-674-A	MOTOR ASSY, SLED (SLED)	

SECTION 5
ELECTRICAL PARTS LIST

DISC IN KEY

NOTE:

- Due to standardization, replacements in the parts list may be different from the parts specified in the diagrams or the components used on the set.
- -XX and -X mean standardized parts, so they may have some difference from the original one.
- RESISTORS
All resistors are in ohms.
METAL: Metal-film resistor.
METAL OXIDE: Metal oxide-film resistor.
F: nonflammable

- Items marked “*” are not stocked since they are seldom required for routine service. Some delay should be anticipated when ordering these items.
- SEMICONDUCTORS
In each case, u : μ , for example:
uA.. : μ A.. uPA.. : μ PA..
uPB.. : μ PB.. uPC.. : μ PC.. uPD.. : μ PD..
- CAPACITORS
uF : μ F
- COILS
uH : μ H

The components identified by mark Δ or dotted line with mark Δ are critical for safety. Replace only with part number specified.

Les composants identifiés par une marque Δ sont critiques pour la sécurité. Ne les remplacer que par une pièce portant le numéro spécifié.

When indicating parts by reference number, please include the board.

Ref. No.	Part No.	Description	Remark	Ref. No.	Part No.	Description	Remark
*	1-659-836-11	DISC IN BOARD ***** < SWITCH >		D901	8-719-018-01	DIODE MA8220-TX	
SW1	1-572-288-21	SWITCH, PUSH (DISC IN)		D902	8-719-017-58	DIODE MA8068-TX	
SW2	1-572-288-21	SWITCH, PUSH (SELF)		D910	8-719-073-01	DIODE MA111-(K8).S0	
*****				D920	8-719-420-90	DIODE MA8051-M-TX	
		KEY BOARD *****		D972	8-719-977-03	DIODE MA8056-M-TX	
	1-694-780-11	CONDUCTIVE BOARD, CONNECTION		D974	8-719-422-94	DIODE MA8091-L-TX	
*	3-227-278-01	PLATE (LCD), LIGHT GUIDE		< FERRITE BEAD >			
*	3-227-279-01	PLATE (LCD), GROUND		FB901	1-414-235-22	INDUCTOR, FERRITE BEAD	
*	3-227-280-01	CASE (IR-T), SHIELD		FB902	1-414-235-22	INDUCTOR, FERRITE BEAD	
*	3-227-283-01	SHEET (ILLUMINATOR)		< IC >			
*	3-227-284-01	SHEET (REFLECTOR)		IC901	8-759-653-26	IC LC75878W	
*	3-230-625-01	SHEET		IC902	8-759-830-18	IC RRX9000-0601#1	
		< CAPACITOR >		IC903	8-759-830-17	IC RRX9000-0401R#01	
C900	1-164-156-11	CERAMIC CHIP 0.1uF	25V	< LIQUID CRYSTAL DISPLAY >			
C901	1-162-974-11	CERAMIC CHIP 0.01uF	50V	LCD901	1-804-308-11	DISPLAY PANEL, LIQUID CRYSTAL	
C902	1-126-205-11	ELECT CHIP 47uF	20% 6.3V	< DIODE >			
C903	1-135-852-21	ELECT CHIP 22uF	20% 6.3V	LED900	8-719-083-14	LED RRX9000-0501 (IR RECEIVE)	
C904	1-164-156-11	CERAMIC CHIP 0.1uF	25V	LED910	8-719-076-58	LED NSSW440-BRS (LCD BACK LIGHT)	
C905	1-135-852-21	ELECT CHIP 22uF	20% 6.3V	LED911	8-719-076-58	LED NSSW440-BRS (LCD BACK LIGHT)	
C906	1-162-974-11	CERAMIC CHIP 0.01uF	50V	LED912	8-719-076-58	LED NSSW440-BRS (LCD BACK LIGHT)	
C907	1-164-388-11	CERAMIC CHIP 270PF	5% 50V	LED913	8-719-076-58	LED NSSW440-BRS (LCD BACK LIGHT)	
C908	1-115-156-11	CERAMIC CHIP 1uF	10V	< SWITCH >			
C910	1-164-156-11	CERAMIC CHIP 0.1uF	25V	LSW921	1-762-619-21	SWITCH, KEYBOARD (WITH LED) (ON/OFF)	
C911	1-164-156-11	CERAMIC CHIP 0.1uF	25V	< TRANSISTOR >			
C912	1-164-156-11	CERAMIC CHIP 0.1uF	25V	Q903	8-729-904-75	TRANSISTOR DTD114EK-T-146	
C982	1-164-227-11	CERAMIC CHIP 0.022uF	10% 25V	< RESISTOR >			
C983	1-115-412-11	CERAMIC CHIP 680PF	5% 25V	R900	1-216-819-11	METAL CHIP 680 5% 1/16W	
C986	1-164-489-11	CERAMIC CHIP 0.22uF	10% 16V	R901	1-216-037-00	METAL CHIP 330 5% 1/10W	
C990	1-164-227-11	CERAMIC CHIP 0.022uF	10% 25V	R902	1-216-846-11	METAL CHIP 120K 5% 1/16W	
C991	1-107-826-11	CERAMIC CHIP 0.1uF	10% 16V	R903	1-216-851-11	METAL CHIP 330K 5% 1/16W	
C992	1-107-826-11	CERAMIC CHIP 0.1uF	10% 16V	R904	1-216-037-00	METAL CHIP 330 5% 1/10W	
C993	1-107-826-11	CERAMIC CHIP 0.1uF	10% 16V	R905	1-216-295-11	SHORT 0	
		< CONNECTOR >		R910	1-216-821-11	METAL CHIP 1K 5% 1/16W	
CN901	1-794-065-22	PLUG, CONNECTOR 14P		R911	1-216-857-11	METAL CHIP 1M 5% 1/16W	
		< DIODE >		R912	1-216-817-11	METAL CHIP 470 5% 1/16W	
D900	8-719-078-81	DIODE DF5A6.8FU(TE85R)		R913	1-216-845-11	METAL CHIP 100K 5% 1/16W	

CDX-CA850/CA850X/CA860X

KEY	LIMIT	LOAD	MAIN
-----	-------	------	------

Ref. No.	Part No.	Description	Remark
R914	1-216-845-11	METAL CHIP	100K 5% 1/16W
R915	1-216-845-11	METAL CHIP	100K 5% 1/16W
R916	1-216-845-11	METAL CHIP	100K 5% 1/16W
R917	1-216-845-11	METAL CHIP	100K 5% 1/16W
R918	1-216-845-11	METAL CHIP	100K 5% 1/16W
R919	1-216-797-11	METAL CHIP	10 5% 1/16W
R921	1-216-029-00	METAL CHIP	150 5% 1/10W
R922	1-216-029-00	METAL CHIP	150 5% 1/10W
R923	1-216-029-00	METAL CHIP	150 5% 1/10W
R924	1-216-029-00	METAL CHIP	150 5% 1/10W
R971	1-216-029-00	METAL CHIP	150 5% 1/10W
R972	1-216-027-00	METAL CHIP	120 5% 1/10W
R973	1-216-029-00	METAL CHIP	150 5% 1/10W
R974	1-216-027-00	METAL CHIP	120 5% 1/10W
R979	1-216-041-00	METAL CHIP	470 5% 1/10W
R980	1-216-029-00	METAL CHIP	150 5% 1/10W
R981	1-216-029-00	METAL CHIP	150 5% 1/10W
R982	1-216-029-00	METAL CHIP	150 5% 1/10W
R983	1-216-857-11	METAL CHIP	1M 5% 1/16W
R984	1-216-821-11	METAL CHIP	1K 5% 1/16W
R985	1-216-821-11	METAL CHIP	1K 5% 1/16W
R986	1-216-821-11	METAL CHIP	1K 5% 1/16W
R987	1-216-841-11	METAL CHIP	47K 5% 1/16W
R988	1-216-029-00	METAL CHIP	150 5% 1/10W
R990	1-216-041-00	METAL CHIP	470 5% 1/10W
R991	1-216-829-11	METAL CHIP	4.7K 5% 1/16W
R992	1-216-829-11	METAL CHIP	4.7K 5% 1/16W
R993	1-216-829-11	METAL CHIP	4.7K 5% 1/16W
R994	1-216-829-11	METAL CHIP	4.7K 5% 1/16W

< VIBRATOR >

X910 1-781-646-21 VIBRATOR, CERAMIC (4MHz)

* 1-659-835-11 LIMIT BOARD

< SWITCH >

SW3 1-572-688-11 SWITCH, PUSH (1 KEY) (LIMIT)

* 1-659-837-11 LOAD BOARD

< SWITCH >

SW4 1-572-288-21 SWITCH, PUSH (DOWN)

Ref. No.	Part No.	Description	Remark
*	A-3283-144-A	MAIN BOARD, COMPLETE (CA850)	
*	A-3283-145-A	MAIN BOARD, COMPLETE (CA860X)	
*	A-3283-146-A	MAIN BOARD, COMPLETE (CA850X)	*****
	1-790-355-53	CORD (WITH CONNECTOR) (RCA)	(SUB OUT (MONO))
*	3-040-998-01	BRACKET (IC)	
*	3-223-780-01	HEAT SINK (CA850)	
*	3-223-780-21	HEAT SINK (CA850X/CA860X)	
*	3-223-783-21	CHASSIS (BACK)	
*	3-223-785-01	HEAT SINK (REG/D)	
	7-685-646-79	SCREW +BVTP 3X8 TYPE2 N-S	
	7-685-790-01	SCREW +PTT 2.6X4 (S)	
	7-685-793-09	SCREW +PTT 2.6X8 (S)	
	7-685-794-09	SCREW +PTT 2.6X10 (S)	
	7-685-797-09	SCREW +PTT 2.6X16 (S)	
		< CAPACITOR >	
C102	1-127-573-11	CERAMIC CHIP	1uF 10% 16V
C103	1-124-259-11	ELECT	4.7uF 20% 16V
C106	1-164-156-11	CERAMIC CHIP	0.1uF 25V
C107	1-164-156-11	CERAMIC CHIP	0.1uF 25V
C108	1-126-936-11	ELECT	3300uF 20% 16V
C201	1-162-918-11	CERAMIC CHIP	18PF 5% 50V
C202	1-162-968-11	CERAMIC CHIP	0.0047uF 10% 50V
C203	1-124-589-11	ELECT	47uF 20% 16V
C204	1-164-156-11	CERAMIC CHIP	0.1uF 25V
C205	1-126-154-11	ELECT	47uF 20% 6.3V
C206	1-162-964-11	CERAMIC CHIP	0.001uF 10% 50V (CA850)
C207	1-164-156-11	CERAMIC CHIP	0.1uF 25V (CA850)
C208	1-162-920-11	CERAMIC CHIP	27PF 5% 50V (CA850)
C209	1-162-920-11	CERAMIC CHIP	27PF 5% 50V (CA850)
C210	1-164-315-11	CERAMIC CHIP	470PF 5% 50V (CA850)
C211	1-107-826-11	CERAMIC CHIP	0.1uF 10% 16V (CA850)
C212	1-162-966-11	CERAMIC CHIP	0.0022uF 10% 50V (CA850)
C213	1-164-739-11	CERAMIC CHIP	560PF 5% 50V (CA850)
C214	1-135-834-11	CERAMIC CHIP	2.2uF 6.3V (CA850)
C215	1-162-959-11	CERAMIC CHIP	330PF 5% 50V (CA850)
C216	1-164-156-11	CERAMIC CHIP	0.1uF 25V (CA850)
C217	1-162-964-11	CERAMIC CHIP	0.001uF 10% 50V (CA850)
C218	1-162-964-11	CERAMIC CHIP	0.001uF 10% 50V (CA850)

Ref. No.	Part No.	Description	Remark	Ref. No.	Part No.	Description	Remark
C219	1-162-964-11	CERAMIC CHIP	0.001uF 10% 50V (CA850)	C332	1-164-156-11	CERAMIC CHIP	0.1uF 25V (CA860X)
C220	1-107-826-11	CERAMIC CHIP	0.1uF 10% 16V (CA850)	C333	1-162-919-11	CERAMIC CHIP	22PF 5% 50V (CA860X)
C221	1-164-315-11	CERAMIC CHIP	470PF 5% 50V (CA850)	C334	1-124-584-00	ELECT	100uF 20% 10V (CA860X)
C222	1-162-915-11	CERAMIC CHIP	10PF 0.5PF 50V (CA850)	C335	1-124-779-00	ELECT CHIP	10uF 20% 16V
C223	1-125-891-11	CERAMIC CHIP	0.47uF 10% 10V (CA850)	C336	1-162-927-11	CERAMIC CHIP	100PF 5% 50V
C224	1-165-176-11	CERAMIC CHIP	0.047uF 10% 16V (CA850)	C337	1-124-779-00	ELECT CHIP	10uF 20% 16V
C225	1-126-785-11	ELECT	47uF 20% 10V (CA850)	C338	1-162-927-11	CERAMIC CHIP	100PF 5% 50V
C226	1-164-156-11	CERAMIC CHIP	0.1uF 25V	C339	1-124-779-00	ELECT CHIP	10uF 20% 16V
C227	1-164-156-11	CERAMIC CHIP	0.1uF 25V	C340	1-162-927-11	CERAMIC CHIP	100PF 5% 50V
C228	1-164-156-11	CERAMIC CHIP	0.1uF 25V (CA850)	C341	1-124-779-00	ELECT CHIP	10uF 20% 16V
C229	1-125-837-11	CERAMIC CHIP	1uF 10% 6.3V	C342	1-162-927-11	CERAMIC CHIP	100PF 5% 50V
C302	1-162-970-11	CERAMIC CHIP	0.01uF 10% 25V	C343	1-126-157-11	ELECT	10uF 20% 16V
C303	1-125-891-11	CERAMIC CHIP	0.47uF 10% 10V	C344	1-104-942-11	ELECT	1uF 20% 50V
C304	1-162-968-11	CERAMIC CHIP	0.0047uF 10% 50V	C345	1-162-927-11	CERAMIC CHIP	100PF 5% 50V
C305	1-125-837-11	CERAMIC CHIP	1uF 10% 6.3V	C346	1-162-927-11	CERAMIC CHIP	100PF 5% 50V
C306	1-165-176-11	CERAMIC CHIP	0.047uF 10% 16V	C347	1-124-589-11	ELECT	47uF 20% 16V
C307	1-162-970-11	CERAMIC CHIP	0.01uF 10% 25V	C349	1-126-157-11	ELECT	10uF 20% 16V (CA860X)
C308	1-126-193-11	ELECT CHIP	1uF 20% 50V	C350	1-115-467-11	CERAMIC CHIP	0.22uF 10% 10V (CA860X)
C309	1-126-193-11	ELECT CHIP	1uF 20% 50V	C350	1-125-891-11	CERAMIC CHIP	0.47uF 10% 10V (CA850/CA850X)
C310	1-126-193-11	ELECT CHIP	1uF 20% 50V	C351	1-115-467-11	CERAMIC CHIP	0.22uF 10% 10V (CA860X)
C311	1-104-942-11	ELECT	1uF 20% 50V	C351	1-125-891-11	CERAMIC CHIP	0.47uF 10% 10V (CA850/CA850X)
C312	1-136-154-00	FILM	0.012uF 5% 50V	C352	1-115-467-11	CERAMIC CHIP	0.22uF 10% 10V (CA860X)
C313	1-162-965-11	CERAMIC CHIP	0.0015uF 10% 50V	C352	1-125-891-11	CERAMIC CHIP	0.47uF 10% 10V (CA850/CA850X)
C314	1-136-154-00	FILM	0.012uF 5% 50V	C353	1-115-467-11	CERAMIC CHIP	0.22uF 10% 10V (CA860X)
C315	1-162-965-11	CERAMIC CHIP	0.0015uF 10% 50V	C353	1-125-891-11	CERAMIC CHIP	0.47uF 10% 10V (CA850/CA850X)
C316	1-126-157-11	ELECT	10uF 20% 16V	C354	1-165-176-11	CERAMIC CHIP	0.047uF 10% 16V (CA860X)
C317	1-127-573-11	CERAMIC CHIP	1uF 10% 16V (CA860X)	C356	1-162-927-11	CERAMIC CHIP	100PF 5% 50V
C318	1-164-156-11	CERAMIC CHIP	0.1uF 25V (CA860X)	C357	1-162-927-11	CERAMIC CHIP	100PF 5% 50V
C319	1-126-157-11	ELECT	10uF 20% 16V (CA860X)	C358	1-124-589-11	ELECT	47uF 20% 16V (CA860X)
C320	1-124-584-00	ELECT	100uF 20% 10V (CA860X)	C358	1-126-157-11	ELECT	10uF 20% 16V (CA850/CA850X)
C321	1-162-919-11	CERAMIC CHIP	22PF 5% 50V (CA860X)	C359	1-164-156-11	CERAMIC CHIP	0.1uF 25V
C322	1-127-573-11	CERAMIC CHIP	1uF 10% 16V (CA860X)	C360	1-164-156-11	CERAMIC CHIP	0.1uF 25V
C323	1-164-156-11	CERAMIC CHIP	0.1uF 25V (CA860X)	C364	1-164-156-11	CERAMIC CHIP	0.1uF 25V
C324	1-124-584-00	ELECT	100uF 20% 10V (CA860X)	C365	1-125-837-11	CERAMIC CHIP	1uF 10% 6.3V (CA860X)
C325	1-162-919-11	CERAMIC CHIP	22PF 5% 50V (CA860X)	C365	1-162-964-11	CERAMIC CHIP	0.001uF 10% 50V (CA850/CA850X)
C326	1-127-573-11	CERAMIC CHIP	1uF 10% 16V (CA860X)	C368	1-164-156-11	CERAMIC CHIP	0.1uF 25V (CA860X)
C327	1-126-785-11	ELECT	47uF 20% 10V	C373	1-162-927-11	CERAMIC CHIP	100PF 5% 50V (CA860X)
C328	1-126-157-11	ELECT	10uF 20% 16V (CA860X)	C373	1-162-966-11	CERAMIC CHIP	0.0022uF 10% 50V (CA850/CA850X)
C329	1-124-584-00	ELECT	100uF 20% 10V (CA860X)	C374	1-162-927-11	CERAMIC CHIP	100PF 5% 50V (CA860X)
C330	1-162-919-11	CERAMIC CHIP	22PF 5% 50V (CA860X)	C374	1-162-966-11	CERAMIC CHIP	0.0022uF 10% 50V (CA850/CA850X)
C331	1-127-573-11	CERAMIC CHIP	1uF 10% 16V (CA860X)	C375	1-162-927-11	CERAMIC CHIP	100PF 5% 50V (CA860X)

CDX-CA850/CA850X/CA860X

MAIN

Ref. No.	Part No.	Description	Remark	Ref. No.	Part No.	Description	Remark
C375	1-162-966-11	CERAMIC CHIP	0.0022uF 10% 50V (CA850/CA850X)	C416	1-162-964-11	CERAMIC CHIP	0.001uF 10% 50V
C376	1-162-927-11	CERAMIC CHIP	100PF 5% 50V (CA860X)	C501	1-164-156-11	CERAMIC CHIP	0.1uF 25V
C376	1-162-966-11	CERAMIC CHIP	0.0022uF 10% 50V (CA850/CA850X)	C503	1-164-156-11	CERAMIC CHIP	0.1uF 25V
C377	1-162-927-11	CERAMIC CHIP	100PF 5% 50V (CA860X)	C504	1-164-156-11	CERAMIC CHIP	0.1uF 25V
C377	1-162-966-11	CERAMIC CHIP	0.0022uF 10% 50V (CA850/CA850X)	C505	1-162-968-11	CERAMIC CHIP	0.0047uF 10% 50V (CA850)
C378	1-164-227-11	CERAMIC CHIP	0.022uF 10% 25V	C505	1-165-176-11	CERAMIC CHIP	0.047uF 10% 16V (CA850X/CA860X)
C379	1-125-837-11	CERAMIC CHIP	1uF 10% 6.3V (CA860X)	C506	1-164-156-11	CERAMIC CHIP	0.1uF 25V
C380	1-125-837-11	CERAMIC CHIP	1uF 10% 6.3V (CA860X)	C507	1-164-315-11	CERAMIC CHIP	470PF 5% 50V
C381	1-125-837-11	CERAMIC CHIP	1uF 10% 6.3V (CA860X)	C508	1-164-230-11	CERAMIC CHIP	220PF 5% 50V
C382	1-125-837-11	CERAMIC CHIP	1uF 10% 6.3V (CA860X)	C509	1-162-921-11	CERAMIC CHIP	33PF 5% 50V
C383	1-164-156-11	CERAMIC CHIP	0.1uF 25V (CA860X)	C510	1-162-917-11	CERAMIC CHIP	15PF 5% 50V
C384	1-164-156-11	CERAMIC CHIP	0.1uF 25V (CA860X)	C511	1-162-964-11	CERAMIC CHIP	0.001uF 10% 50V
C385	1-125-889-11	CERAMIC CHIP	2.2uF 10% 10V	C512	1-135-834-11	CERAMIC CHIP	2.2uF 6.3V
C386	1-162-919-11	CERAMIC CHIP	22PF 5% 50V (CA860X)	C513	1-164-156-11	CERAMIC CHIP	0.1uF 25V
C386	1-162-964-11	CERAMIC CHIP	0.001uF 10% 50V (CA850/CA850X)	C514	1-162-927-11	CERAMIC CHIP	100PF 5% 50V (CA850)
C387	1-162-919-11	CERAMIC CHIP	22PF 5% 50V (CA860X)	C515	1-162-974-11	CERAMIC CHIP	0.01uF 50V
C387	1-162-964-11	CERAMIC CHIP	0.001uF 10% 50V (CA850/CA850X)	C516	1-162-974-11	CERAMIC CHIP	0.01uF 50V
C388	1-162-919-11	CERAMIC CHIP	22PF 5% 50V (CA860X)	C518	1-164-156-11	CERAMIC CHIP	0.1uF 25V
C388	1-162-964-11	CERAMIC CHIP	0.001uF 10% 50V (CA850/CA850X)	C519	1-107-877-11	ELECT	1000uF 20% 10V
C389	1-162-919-11	CERAMIC CHIP	22PF 5% 50V (CA860X)	C520	1-125-701-11	DOUBLE LAYERS	0.047F 5.5V
C389	1-162-964-11	CERAMIC CHIP	0.001uF 10% 50V (CA850/CA850X)	C521	1-124-584-00	ELECT	100uF 20% 10V
C390	1-162-964-11	CERAMIC CHIP	0.001uF 10% 50V (CA850)	C522	1-164-156-11	CERAMIC CHIP	0.1uF 25V
C391	1-125-837-11	CERAMIC CHIP	1uF 10% 6.3V (CA860X)	C601	1-162-974-11	CERAMIC CHIP	0.01uF 50V
C392	1-164-156-11	CERAMIC CHIP	0.1uF 25V (CA860X)	C602	1-125-837-11	CERAMIC CHIP	1uF 10% 6.3V
C393	1-127-715-11	CERAMIC CHIP	0.22uF 10% 16V	C603	1-162-927-11	CERAMIC CHIP	100PF 5% 50V
C394	1-127-715-11	CERAMIC CHIP	0.22uF 10% 16V	C604	1-104-653-11	ELECT	220uF 20% 16V
C401	1-107-826-11	CERAMIC CHIP	0.1uF 10% 16V	C701	1-162-964-11	CERAMIC CHIP	0.001uF 10% 50V
C402	1-162-961-11	CERAMIC CHIP	330PF 10% 50V	C702	1-164-156-11	CERAMIC CHIP	0.1uF 25V
C403	1-126-154-11	ELECT	47uF 20% 6.3V	C703	1-164-156-11	CERAMIC CHIP	0.1uF 25V
C404	1-165-128-11	CERAMIC CHIP	0.22uF 16V	C704	1-164-156-11	CERAMIC CHIP	0.1uF 25V
C405	1-126-154-11	ELECT	47uF 20% 6.3V	C705	1-164-156-11	CERAMIC CHIP	0.1uF 25V
C406	1-126-154-11	ELECT	47uF 20% 6.3V	C706	1-164-156-11	CERAMIC CHIP	0.1uF 25V
C407	1-126-176-11	ELECT	220uF 20% 10V	C707	1-107-826-11	CERAMIC CHIP	0.1uF 10% 16V
C408	1-128-057-11	ELECT	330uF 20% 6.3V	C708	1-126-205-11	ELECT CHIP	47uF 20% 6.3V
C410	1-107-826-11	CERAMIC CHIP	0.1uF 10% 16V	C709	1-107-826-11	CERAMIC CHIP	0.1uF 10% 16V
C411	1-162-923-11	CERAMIC CHIP	47PF 5% 50V (CA850)	C710	1-162-974-11	CERAMIC CHIP	0.01uF 50V
C412	1-162-923-11	CERAMIC CHIP	47PF 5% 50V (CA850)	C711	1-162-970-11	CERAMIC CHIP	0.01uF 10% 25V
C413	1-162-964-11	CERAMIC CHIP	0.001uF 10% 50V	C712	1-126-401-21	ELECT CHIP	1uF 20% 50V
C414	1-162-964-11	CERAMIC CHIP	0.001uF 10% 50V	C713	1-162-970-11	CERAMIC CHIP	0.01uF 10% 25V
C415	1-162-964-11	CERAMIC CHIP	0.001uF 10% 50V	C714	1-162-964-11	CERAMIC CHIP	0.001uF 10% 50V
				C715	1-164-156-11	CERAMIC CHIP	0.1uF 25V
				C716	1-164-156-11	CERAMIC CHIP	0.1uF 25V
				C717	1-162-927-11	CERAMIC CHIP	100PF 5% 50V
				C718	1-162-927-11	CERAMIC CHIP	100PF 5% 50V
				C722	1-162-974-11	CERAMIC CHIP	0.01uF 50V
				C723	1-162-974-11	CERAMIC CHIP	0.01uF 50V
				C801	1-162-974-11	CERAMIC CHIP	0.01uF 50V
				C802	1-162-974-11	CERAMIC CHIP	0.01uF 50V
				C803	1-128-526-11	ELECT	100uF 20% 10V
				C804	1-125-891-11	CERAMIC CHIP	0.47uF 10% 10V
				C805	1-124-589-11	ELECT	47uF 20% 16V (CA860X)
				C806	1-126-154-11	ELECT	47uF 20% 6.3V (CA860X)
						< CONNECTOR >	
				CN101	1-774-701-11	PIN, CONNECTOR 16P	
				* CN301	1-564-506-11	PLUG, CONNECTOR 3P	

Ref. No.	Part No.	Description	Remark	Ref. No.	Part No.	Description	Remark
CN401	1-764-617-12	PIN, CONNECTOR (PC BOARD) 30P		FB403	1-414-235-22	INDUCTOR, FERRITE BEAD (CA850)	
CN601	1-580-907-31	PLUG, CONNECTOR (BUS CONTROL IN)		FB501	1-414-235-22	INDUCTOR, FERRITE BEAD	
CN701	1-784-456-11	CONNECTOR, FFC/FPC 14P		FB701	1-414-235-22	INDUCTOR, FERRITE BEAD	
		< JACK >				< IC >	
CN201	1-815-185-11	JACK (ANTENNA)		IC201	8-759-492-59	IC SAA6588T/V2-118 (CA850)	
CN302	1-774-700-11	JACK, PIN 6P (BUS AUDIO IN,AUDIO OUT)		IC202	8-759-909-71	IC BA4558F-E2 (CA850)	
		< DIODE >		IC301	8-759-827-13	IC TDA7406T	
D101	8-719-049-38	DIODE 1N5404TU		IC302	8-759-826-90	IC NJM2160AV-TE2 (CA860X)	
D102	8-719-017-58	DIODE MA8068		IC303	8-759-826-90	IC NJM2160AV-TE2 (CA860X)	
D105	8-719-073-01	DIODE MA111-(K8).SO		IC304	8-759-832-29	IC NJM4580M-(TE2)	
D106	8-719-053-18	DIODE 1SR154-400TE-25		IC305	8-759-832-29	IC NJM4580M-(TE2)	
D107	8-719-053-18	DIODE 1SR154-400TE-25		IC308	8-759-100-96	IC uPC4558G2 (CA860X)	
				IC309	8-759-100-96	IC uPC4558G2 (CA860X)	
D110	8-719-975-40	DIODE RB411D-T146 (CA860X)		IC310	8-759-198-34	IC TA75S558F(TE85R) (CA860X)	
D202	8-719-073-01	DIODE MA111-(K8).SO		IC351	8-759-660-96	IC TDA7560 (CA860X)	
D203	8-719-422-41	DIODE MA8051-L-TX		IC351	8-759-827-14	IC TA8268AH (CA850/CA850X)	
D204	8-719-800-76	DIODE 1SS226 (CA850)		IC501	6-800-243-01	IC MB90574BPMT-G-335-BND (CA850)	
D301	8-719-200-82	DIODE 11ES2		IC501	8-759-837-48	IC MB90574BPMT-G-323-BND (CA850X/CA860X)	
D302	8-719-200-82	DIODE 11ES2		IC502	8-759-828-22	IC XC61CN4102MR	
D303	8-719-200-82	DIODE 11ES2					
D304	8-719-053-18	DIODE 1SR154-400TE-25		IC601	8-759-449-89	IC BA8270F-E2	
D305	8-719-200-82	DIODE 11ES2		IC701	6-800-141-01	IC HD6432355A37F	
D306	8-719-200-82	DIODE 11ES2		IC702	8-759-277-63	IC TC7W14FU(TE12R)	
D307	8-719-200-82	DIODE 11ES2		IC801	8-759-460-80	IC BA10FP-E2 (CA860X)	
D308	8-719-200-82	DIODE 11ES2				< JACK >	
D310	8-719-801-78	DIODE 1SS184		J651	1-566-822-41	JACK (REMOTE IN) (CA850)	
D311	8-719-073-01	DIODE MA111-(K8).SO				< COIL >	
D401	8-719-017-67	DIODE MA8068-H		L101	1-419-476-11	COIL, CHOKE 250uH	
D402	8-719-422-64	DIODE MA8062-M		L201	1-216-864-11	SHORT 0	
D501	8-719-801-78	DIODE 1SS184		L202	1-216-296-11	SHORT 0	
D503	8-719-977-03	DIODE DTZ5.6B				< TRANSISTOR >	
D504	8-719-073-01	DIODE MA111-(K8).SO		Q101	8-729-120-28	TRANSISTOR 2SC1623-L5L6	
D505	8-719-422-41	DIODE MA8051-L-TX (CA850)		Q102	8-729-120-28	TRANSISTOR 2SC1623-L5L6	
D601	8-719-073-01	DIODE MA111-(K8).SO		Q103	8-729-120-28	TRANSISTOR 2SC1623-L5L6	
D603	8-719-017-94	DIODE MA8180		Q104	8-729-049-13	TRANSISTOR UPA1853GR-9JG-E1	
D604	8-719-420-51	DIODE MA729		Q105	8-729-421-22	TRANSISTOR UN2211	
D605	8-719-018-01	DIODE MA8220-TX		Q106	8-729-421-22	TRANSISTOR UN2211	
D606	8-719-018-01	DIODE MA8220-TX		Q201	8-729-106-60	TRANSISTOR 2SB1115A-YQ	
D607	8-719-801-78	DIODE 1SS184		Q202	8-729-421-22	TRANSISTOR UN2211	
D608	8-719-073-01	DIODE MA111-(K8).SO		Q204	8-729-120-28	TRANSISTOR 2SC1623-L5L6 (CA850)	
D609	8-719-422-64	DIODE MA8062-M		Q205	8-729-421-22	TRANSISTOR UN2211 (CA850)	
D610	8-719-073-01	DIODE MA111-(K8).SO		Q207	8-729-920-85	TRANSISTOR 2SD1664-QR	
D653	8-719-820-05	DIODE 1SS181		Q303	8-729-421-22	TRANSISTOR UN2211	
D703	8-719-018-01	DIODE MA8220-TX		Q304	8-729-424-08	TRANSISTOR UN2111	
D707	8-719-017-58	DIODE MA8068		Q306	8-729-021-95	TRANSISTOR RN1441-A(TE85L) (CA860X)	
D708	8-719-018-01	DIODE MA8220-TX		Q306	8-729-920-21	TRANSISTOR DTC314TKH04 (CA850/CA850X)	
D715	8-719-801-78	DIODE 1SS184		Q307	8-729-021-95	TRANSISTOR RN1441-A(TE85L) (CA860X)	
D801	8-719-420-14	DIODE MA8082-M		Q307	8-729-920-21	TRANSISTOR DTC314TKH04 (CA850/CA850X)	
D802	8-719-420-92	DIODE MA8051-M-TX		Q308	8-729-021-95	TRANSISTOR RN1441-A(TE85L) (CA860X)	
		< FERRITE BEAD >		Q308	8-729-920-21	TRANSISTOR DTC314TKH04 (CA850/CA850X)	
FB201	1-414-235-22	INDUCTOR, FERRITE BEAD (CA850)		Q309	8-729-021-95	TRANSISTOR RN1441-A(TE85L) (CA860X)	
FB301	1-414-235-22	INDUCTOR, FERRITE BEAD		Q309	8-729-920-21	TRANSISTOR DTC314TKH04 (CA850/CA850X)	
FB401	1-414-235-22	INDUCTOR, FERRITE BEAD					
FB402	1-414-235-22	INDUCTOR, FERRITE BEAD					
FB403	1-414-234-22	INDUCTOR, FERRITE BEAD (CA850X/CA860X)					

CDX-CA850/CA850X/CA860X

MAIN

Ref. No.	Part No.	Description	Remark	Ref. No.	Part No.	Description	Remark
Q310	8-729-920-21	TRANSISTOR DTC314TKH04		R210	1-216-853-11	METAL CHIP 470K 5%	1/16W (CA850)
Q401	8-729-021-82	TRANSISTOR 2SD2396K		R211	1-216-797-11	METAL CHIP 10 5%	1/16W (CA850)
Q402	8-729-421-22	TRANSISTOR UN2211		R212	1-216-825-11	METAL CHIP 2.2K 5%	1/16W (CA850)
Q403	8-729-424-08	TRANSISTOR UN2111		R213	1-216-825-11	METAL CHIP 2.2K 5%	1/16W (CA850)
Q405	8-729-421-22	TRANSISTOR UN2211		R214	1-216-857-11	METAL CHIP 1M 5%	1/16W (CA850)
Q406	8-729-920-85	TRANSISTOR 2SD1664-QR		R215	1-216-809-11	METAL CHIP 100 5%	1/16W (CA850)
Q407	8-729-424-08	TRANSISTOR UN2111-TX		R216	1-216-833-11	METAL CHIP 10K 5%	1/16W (CA850)
Q501	8-729-040-17	TRANSISTOR 2SD2164-K		R217	1-216-833-11	METAL CHIP 10K 5%	1/16W (CA850)
Q602	8-729-421-22	TRANSISTOR UN2211		R218	1-216-809-11	METAL CHIP 100 5%	1/16W (CA850)
Q603	8-729-424-18	TRANSISTOR UN2113		R219	1-216-845-11	METAL CHIP 100K 5%	1/16W (CA850)
Q701	8-729-424-08	TRANSISTOR UN2111		R220	1-216-825-11	METAL CHIP 2.2K 5%	1/16W (CA850)
Q702	8-729-106-60	TRANSISTOR 2SB1115A-YQ		R221	1-216-841-11	METAL CHIP 47K 5%	1/16W
Q703	8-729-120-28	TRANSISTOR 2SC1623-L5L6		R222	1-216-809-11	METAL CHIP 100 5%	1/16W (CA850)
Q705	8-729-026-49	TRANSISTOR 2SA1037AK-T146-R		R222	1-216-864-11	SHORT 0	(CA850X/CA860X)
Q706	8-729-120-28	TRANSISTOR 2SC1623-L5L6		R223	1-216-809-11	METAL CHIP 100 5%	1/16W (CA850)
Q801	8-729-024-95	TRANSISTOR 2SB1565EF		R223	1-216-864-11	SHORT 0	(CA850X/CA860X)
Q802	8-729-120-28	TRANSISTOR 2SC1623-L5L6		R301	1-216-841-11	METAL CHIP 47K 5%	1/16W
Q803	8-729-120-28	TRANSISTOR 2SC1623-L5L6		R302	1-216-845-11	METAL CHIP 100K 5%	1/16W
< RESISTOR >				R303	1-216-833-11	METAL CHIP 10K 5%	1/16W
R101	1-216-821-11	METAL CHIP 1K 5%	1/16W	R304	1-216-833-11	METAL CHIP 10K 5%	1/16W
R102	1-216-073-00	METAL CHIP 10K 5%	1/10W	R305	1-216-833-11	METAL CHIP 10K 5%	1/16W
R103	1-216-073-00	METAL CHIP 10K 5%	1/10W	R306	1-216-833-11	METAL CHIP 10K 5%	1/16W
R104	1-216-821-11	METAL CHIP 1K 5%	1/16W	R307	1-216-833-11	METAL CHIP 10K 5%	1/16W
R105	1-216-841-11	METAL CHIP 47K 5%	1/16W	R308	1-216-833-11	METAL CHIP 10K 5%	1/16W
R106	1-216-829-11	METAL CHIP 4.7K 5%	1/16W	R309	1-216-833-11	METAL CHIP 10K 5%	1/16W
R107	1-216-841-11	METAL CHIP 47K 5%	1/16W	R310	1-216-833-11	METAL CHIP 10K 5%	1/16W
R108	1-216-829-11	METAL CHIP 4.7K 5%	1/16W	R311	1-216-845-11	METAL CHIP 100K 5%	1/16W (CA860X)
R109	1-216-829-11	METAL CHIP 4.7K 5%	1/16W	R312	1-216-833-11	METAL CHIP 10K 5%	1/16W
R110	1-216-845-11	METAL CHIP 100K 5%	1/16W	R313	1-216-864-11	SHORT 0	(CA850/CA850X)
R111	1-216-837-11	METAL CHIP 22K 5%	1/16W	R314	1-216-833-11	METAL CHIP 10K 5%	1/16W
R113	1-216-833-11	METAL CHIP 10K 5%	1/16W	R315	1-216-797-11	METAL CHIP 10 5%	1/16W (CA860X)
R114	1-216-833-11	METAL CHIP 10K 5%	1/16W	R316	1-216-817-11	METAL CHIP 470 5%	1/16W (CA860X)
R115	1-216-833-11	METAL CHIP 10K 5%	1/16W	R317	1-216-839-11	METAL CHIP 33K 5%	1/16W (CA860X)
R116	1-216-833-11	METAL CHIP 10K 5%	1/16W	R318	1-216-837-11	METAL CHIP 22K 5%	1/16W (CA860X)
R117	1-216-833-11	METAL CHIP 10K 5%	1/16W	R319	1-216-837-11	METAL CHIP 22K 5%	1/16W (CA860X)
R118	1-216-833-11	METAL CHIP 10K 5%	1/16W	R320	1-216-817-11	METAL CHIP 470 5%	1/16W (CA860X)
R125	1-216-841-11	METAL CHIP 47K 5%	1/16W				
R130	1-216-073-00	METAL CHIP 10K 5%	1/10W				
R131	1-216-073-00	METAL CHIP 10K 5%	1/10W				
R201	1-216-797-11	METAL CHIP 10 5%	1/16W				
R202	1-216-831-11	METAL CHIP 6.8K 5%	1/16W				
R203	1-216-833-11	METAL CHIP 10K 5%	1/16W				
R204	1-216-829-11	METAL CHIP 4.7K 5%	1/16W				
R205	1-216-817-11	METAL CHIP 470 5%	1/16W				
R206	1-216-817-11	METAL CHIP 470 5%	1/16W (CA850)				
R207	1-216-797-11	METAL CHIP 10 5%	1/16W (CA850)				
R208	1-216-832-11	METAL CHIP 8.2K 5%	1/16W (CA850)				
R209	1-216-821-11	METAL CHIP 1K 5%	1/16W (CA850)				

Ref. No.	Part No.	Description	Remark	Ref. No.	Part No.	Description	Remark
R321	1-216-797-11	METAL CHIP	10 5% 1/16W (CA860X)	R368	1-216-805-11	METAL CHIP	47 5% 1/16W
R322	1-216-839-11	METAL CHIP	33K 5% 1/16W (CA860X)	R369	1-216-821-11	METAL CHIP	1K 5% 1/16W
R323	1-216-797-11	METAL CHIP	10 5% 1/16W (CA860X)	R370	1-216-833-11	METAL CHIP	10K 5% 1/16W (CA860X)
R324	1-216-817-11	METAL CHIP	470 5% 1/16W (CA860X)	R370	1-216-841-11	METAL CHIP	47K 5% 1/16W (CA850/CA850X)
R325	1-216-839-11	METAL CHIP	33K 5% 1/16W (CA860X)	R372	1-216-801-11	METAL CHIP	22 5% 1/16W (CA860X)
R326	1-216-837-11	METAL CHIP	22K 5% 1/16W (CA860X)	R372	1-216-831-11	METAL CHIP	6.8K 5% 1/16W (CA850/CA850X)
R327	1-216-837-11	METAL CHIP	22K 5% 1/16W (CA860X)	R373	1-216-833-11	METAL CHIP	10K 5% 1/16W
R328	1-216-817-11	METAL CHIP	470 5% 1/16W (CA860X)	R375	1-216-813-11	METAL CHIP	220 5% 1/16W
R329	1-216-797-11	METAL CHIP	10 5% 1/16W (CA860X)	R376	1-216-813-11	METAL CHIP	220 5% 1/16W
R330	1-216-839-11	METAL CHIP	33K 5% 1/16W (CA860X)	R377	1-216-813-11	METAL CHIP	220 5% 1/16W
R331	1-216-821-11	METAL CHIP	1K 5% 1/16W	R378	1-216-813-11	METAL CHIP	220 5% 1/16W
R332	1-216-833-11	METAL CHIP	10K 5% 1/16W	R379	1-216-813-11	METAL CHIP	220 5% 1/16W
R333	1-216-833-11	METAL CHIP	10K 5% 1/16W	R380	1-216-864-11	SHORT	0
R334	1-216-821-11	METAL CHIP	1K 5% 1/16W	R381	1-216-864-11	SHORT	0
R335	1-216-813-11	METAL CHIP	220 5% 1/16W (CA860X)	R382	1-216-864-11	SHORT	0
R335	1-216-864-11	SHORT	0 (CA850/CA850X)	R383	1-216-835-11	METAL CHIP	15K 5% 1/16W (CA860X)
R336	1-216-841-11	METAL CHIP	47K 5% 1/16W (CA850/CA850X)	R383	1-216-864-11	SHORT	0 (CA850/CA850X)
R337	1-216-813-11	METAL CHIP	220 5% 1/16W (CA860X)	R384	1-216-835-11	METAL CHIP	15K 5% 1/16W (CA860X)
R337	1-216-864-11	SHORT	0 (CA850/CA850X)	R384	1-216-864-11	SHORT	0 (CA850/CA850X)
R338	1-216-841-11	METAL CHIP	47K 5% 1/16W (CA850/CA850X)	R385	1-216-835-11	METAL CHIP	15K 5% 1/16W (CA860X)
R339	1-216-813-11	METAL CHIP	220 5% 1/16W (CA860X)	R385	1-216-864-11	SHORT	0 (CA850/CA850X)
R339	1-216-864-11	SHORT	0 (CA850/CA850X)	R386	1-216-835-11	METAL CHIP	15K 5% 1/16W (CA860X)
R340	1-216-841-11	METAL CHIP	47K 5% 1/16W (CA850/CA850X)	R386	1-216-864-11	SHORT	0 (CA850/CA850X)
R341	1-216-813-11	METAL CHIP	220 5% 1/16W (CA860X)	R387	1-216-833-11	METAL CHIP	10K 5% 1/16W (CA860X)
R341	1-216-864-11	SHORT	0 (CA850/CA850X)	R388	1-216-825-11	METAL CHIP	2.2K 5% 1/16W (CA860X)
R342	1-216-841-11	METAL CHIP	47K 5% 1/16W (CA850/CA850X)	R389	1-216-833-11	METAL CHIP	10K 5% 1/16W (CA860X)
R343	1-216-864-11	SHORT	0 (CA850/CA850X)	R390	1-216-825-11	METAL CHIP	2.2K 5% 1/16W (CA860X)
R344	1-216-841-11	METAL CHIP	47K 5% 1/16W	R391	1-216-833-11	METAL CHIP	10K 5% 1/16W (CA860X)
R345	1-216-864-11	SHORT	0 (CA850/CA850X)	R392	1-216-825-11	METAL CHIP	2.2K 5% 1/16W (CA860X)
R346	1-216-864-11	SHORT	0 (CA850/CA850X)	R393	1-216-833-11	METAL CHIP	10K 5% 1/16W (CA860X)
R347	1-216-864-11	SHORT	0 (CA850/CA850X)	R394	1-216-825-11	METAL CHIP	2.2K 5% 1/16W (CA860X)
R348	1-216-864-11	SHORT	0 (CA850/CA850X)	R395	1-216-845-11	METAL CHIP	100K 5% 1/16W (CA860X)
R357	1-216-864-11	SHORT	0 (CA850/CA850X)	R396	1-216-845-11	METAL CHIP	100K 5% 1/16W (CA860X)
R358	1-216-864-11	SHORT	0 (CA850/CA850X)	R397	1-216-845-11	METAL CHIP	100K 5% 1/16W (CA860X)
R359	1-216-864-11	SHORT	0 (CA850/CA850X)	R398	1-216-845-11	METAL CHIP	100K 5% 1/16W (CA860X)
R360	1-216-864-11	SHORT	0 (CA850/CA850X)				
R364	1-216-829-11	METAL CHIP	4.7K 5% 1/16W				
R365	1-216-864-11	SHORT	0 (CA850/CA850X)				

CDX-CA850/CA850X/CA860X

MAIN

Ref. No.	Part No.	Description			Remark	Ref. No.	Part No.	Description			Remark
R399	1-216-837-11	METAL CHIP	22K	5%	1/16W (CA860X)	R533	1-216-864-11	SHORT	0		
R400	1-216-833-11	METAL CHIP	10K	5%	1/16W (CA860X)	R534	1-216-864-11	SHORT	0		
R401	1-216-825-11	METAL CHIP	2.2K	5%	1/16W	R535	1-216-864-11	SHORT	0		
R402	1-216-825-11	METAL CHIP	2.2K	5%	1/16W	R536	1-216-864-11	SHORT	0		
R403	1-216-825-11	METAL CHIP	2.2K	5%	1/16W	R539	1-216-845-11	METAL CHIP	100K	5%	1/16W
R405	1-216-864-11	SHORT	0			R540	1-216-864-11	SHORT	0		
R406	1-216-793-11	RES-CHIP	4.7	5%	1/16W	R541	1-216-821-11	METAL CHIP	1K	5%	1/16W
R407	1-216-805-11	METAL CHIP	47	5%	1/16W	R601	1-216-809-11	METAL CHIP	100	5%	1/16W
R408	1-216-797-11	METAL CHIP	10	5%	1/16W	R604	1-216-821-11	METAL CHIP	1K	5%	1/16W
R410	1-216-801-11	METAL CHIP	22	5%	1/16W	R605	1-216-809-11	METAL CHIP	100	5%	1/16W
R417	1-216-825-11	METAL CHIP	2.2K	5%	1/16W	R607	1-216-835-11	METAL CHIP	15K	5%	1/16W
R422	1-216-839-11	METAL CHIP	33K	5%	1/16W (CA860X)	R652	1-218-871-11	METAL CHIP	10K	0.5%	1/16W
R423	1-216-839-11	METAL CHIP	33K	5%	1/16W (CA860X)	R653	1-216-809-11	METAL CHIP	100	5%	1/16W
R424	1-216-839-11	METAL CHIP	33K	5%	1/16W (CA860X)	R654	1-216-809-11	METAL CHIP	100	5%	1/16W (CA850)
R425	1-216-839-11	METAL CHIP	33K	5%	1/16W (CA860X)	R702	1-216-809-11	METAL CHIP	100	5%	1/16W
R426	1-216-821-11	METAL CHIP	1K	5%	1/16W	R703	1-216-845-11	METAL CHIP	100K	5%	1/16W
R427	1-216-821-11	METAL CHIP	1K	5%	1/16W	R704	1-216-864-11	SHORT	0		
R428	1-216-821-11	METAL CHIP	1K	5%	1/16W	R705	1-216-864-11	SHORT	0		
R429	1-216-821-11	METAL CHIP	1K	5%	1/16W	R706	1-216-809-11	METAL CHIP	100	5%	1/16W
R430	1-216-864-11	SHORT	0			R707	1-216-845-11	METAL CHIP	100K	5%	1/16W
R501	1-216-845-11	METAL CHIP	100K	5%	1/16W	R708	1-216-845-11	METAL CHIP	100K	5%	1/16W
R503	1-216-845-11	METAL CHIP	100K	5%	1/16W (CA860X)	R709	1-216-845-11	METAL CHIP	100K	5%	1/16W
R504	1-216-845-11	METAL CHIP	100K	5%	1/16W	R711	1-216-037-00	METAL CHIP	330	5%	1/10W
R505	1-216-864-11	SHORT	0		(CA850)	R712	1-216-829-11	METAL CHIP	4.7K	5%	1/16W
R506	1-216-837-11	METAL CHIP	22K	5%	1/16W	R713	1-216-825-11	METAL CHIP	2.2K	5%	1/16W
R507	1-216-845-11	METAL CHIP	100K	5%	1/16W	R714	1-216-813-11	METAL CHIP	220	5%	1/16W
R508	1-216-833-11	METAL CHIP	10K	5%	1/16W	R715	1-216-813-11	METAL CHIP	220	5%	1/16W
R509	1-216-833-11	METAL CHIP	10K	5%	1/16W	R716	1-216-813-11	METAL CHIP	220	5%	1/16W
R510	1-216-841-11	METAL CHIP	47K	5%	1/16W	R717	1-216-809-11	METAL CHIP	100	5%	1/16W
R511	1-216-809-11	METAL CHIP	100	5%	1/16W	R718	1-216-809-11	METAL CHIP	100	5%	1/16W
R512	1-216-845-11	METAL CHIP	100K	5%	1/16W	R719	1-216-821-11	METAL CHIP	1K	5%	1/16W
R513	1-216-829-11	METAL CHIP	4.7K	5%	1/16W	R720	1-218-871-11	METAL CHIP	10K	0.5%	1/16W
R514	1-216-813-11	METAL CHIP	220	5%	1/16W	R721	1-218-871-11	METAL CHIP	10K	0.5%	1/16W
R515	1-216-845-11	METAL CHIP	100K	5%	1/16W	R724	1-216-845-11	METAL CHIP	100K	5%	1/16W
R516	1-216-864-11	SHORT	0			R728	1-216-845-11	METAL CHIP	100K	5%	1/16W
R517	1-216-864-11	SHORT	0		(CA860X)	R729	1-216-821-11	METAL CHIP	1K	5%	1/16W
R520	1-216-864-11	SHORT	0			R731	1-216-813-11	METAL CHIP	220	5%	1/16W
R521	1-216-809-11	METAL CHIP	100	5%	1/16W	R732	1-216-821-11	METAL CHIP	1K	5%	1/16W
R522	1-216-845-11	METAL CHIP	100K	5%	1/16W	R733	1-216-037-00	METAL CHIP	330	5%	1/10W
R523	1-216-845-11	METAL CHIP	100K	5%	1/16W	R734	1-216-821-11	METAL CHIP	1K	5%	1/16W
R524	1-216-845-11	METAL CHIP	100K	5%	1/16W	R735	1-216-821-11	METAL CHIP	1K	5%	1/16W
R525	1-216-853-11	METAL CHIP	470K	5%	1/16W	R736	1-216-821-11	METAL CHIP	1K	5%	1/16W
R526	1-216-835-11	METAL CHIP	15K	5%	1/16W	R737	1-216-829-11	METAL CHIP	4.7K	5%	1/16W
R527	1-216-793-11	RES-CHIP	4.7	5%	1/16W	R738	1-216-829-11	METAL CHIP	4.7K	5%	1/16W
R530	1-216-821-11	METAL CHIP	1K	5%	1/16W	R739	1-216-829-11	METAL CHIP	4.7K	5%	1/16W
R531	1-216-821-11	METAL CHIP	1K	5%	1/16W	R740	1-216-829-11	METAL CHIP	4.7K	5%	1/16W
R532	1-216-864-11	SHORT	0			R741	1-216-037-00	METAL CHIP	330	5%	1/10W
						R742	1-216-833-11	METAL CHIP	10K	5%	1/16W
						R743	1-216-833-11	METAL CHIP	10K	5%	1/16W
						R744	1-216-821-11	METAL CHIP	1K	5%	1/16W
						R745	1-216-005-00	METAL CHIP	15	5%	1/10W

MAIN

SERVO

Ref. No.	Part No.	Description		Remark
R746	1-216-005-00	METAL CHIP	15	5% 1/10W
R747	1-216-005-00	METAL CHIP	15	5% 1/10W
R748	1-216-005-00	METAL CHIP	15	5% 1/10W
R749	1-216-005-00	METAL CHIP	15	5% 1/10W
R750	1-216-005-00	METAL CHIP	15	5% 1/10W
R801	1-216-829-11	METAL CHIP	4.7K	5% 1/16W
R802	1-216-833-11	METAL CHIP	10K	5% 1/16W
R803	1-216-821-11	METAL CHIP	1K	5% 1/16W
R804	1-216-817-11	METAL CHIP	470	5% 1/16W
R805	1-216-825-11	METAL CHIP	2.2K	5% 1/16W
R806	1-216-864-11	SHORT	0	
R813	1-216-815-11	METAL CHIP	330	5% 1/16W (CA860X)
< SWITCH >				
S101	1-692-431-21	SWITCH, TACTILE (RESET)		
S102	1-771-540-11	SWITCH, PUSH (1 KEY) (NOSE DET)		
< THERMISTOR (POSITIVE) >				
TH101	1-810-940-11	THERMISTOR, POSITIVE		
TH102	1-810-940-11	THERMISTOR, POSITIVE		
TH601	1-801-792-21	THERMISTOR, POSITIVE		
< TUNER >				
TUX201	A-3220-812-A	TUNER UNIT (TUX-020)		
< VIBRATOR >				
X201	1-767-853-21	VIBRATOR, CRYSTAL (4.332MHz) (CA850)		
X501	1-567-098-41	VIBRATOR, CRYSTAL (32.768kHz)		
X502	1-767-833-21	VIBRATOR, CERAMIC (3.68MHz)		
X701	1-781-822-21	VIBRATOR, CERAMIC (18.432MHz)		

*	A-3326-231-A	SERVO BOARD, COMPLETE		

< CAPACITOR >				
C101	1-115-156-11	CERAMIC CHIP	1uF	10V
C103	1-104-609-11	ELECT CHIP	100uF	20% 4V
C104	1-115-156-11	CERAMIC CHIP	1uF	10V
C106	1-107-826-11	CERAMIC CHIP	0.1uF	10% 16V
C107	1-125-837-11	CERAMIC CHIP	1uF	10% 6.3V
C108	1-162-974-11	CERAMIC CHIP	0.01uF	50V
C109	1-162-917-11	CERAMIC CHIP	15PF	5% 50V
C111	1-115-156-11	CERAMIC CHIP	1uF	10V
C115	1-164-733-11	CERAMIC CHIP	820PF	10% 50V
C116	1-165-128-11	CERAMIC CHIP	0.22uF	16V
C117	1-164-733-11	CERAMIC CHIP	820PF	10% 50V
C118	1-164-360-11	CERAMIC CHIP	0.1uF	16V
C127	1-104-851-11	TANTAL. CHIP	10uF	20% 10V
C301	1-126-393-11	ELECT CHIP	33uF	20% 10V
C302	1-164-360-11	CERAMIC CHIP	0.1uF	16V
C303	1-164-227-11	CERAMIC CHIP	0.022uF	10% 25V

Ref. No.	Part No.	Description		Remark
C304	1-164-227-11	CERAMIC CHIP	0.022uF	10% 25V
C305	1-162-965-11	CERAMIC CHIP	0.0015uF	10% 50V
C306	1-162-965-11	CERAMIC CHIP	0.0015uF	10% 50V
C307	1-162-962-11	CERAMIC CHIP	470PF	10% 50V
C308	1-162-962-11	CERAMIC CHIP	470PF	10% 50V
C309	1-164-227-11	CERAMIC CHIP	0.022uF	10% 25V
C310	1-125-838-11	CERAMIC CHIP	2.2uF	10% 6.3V
C311	1-164-677-11	CERAMIC CHIP	0.033uF	10% 16V
C312	1-164-360-11	CERAMIC CHIP	0.1uF	16V
C501	1-126-391-11	ELECT CHIP	47uF	20% 6.3V
C502	1-162-965-11	CERAMIC CHIP	0.0015uF	10% 50V
C504	1-162-967-11	CERAMIC CHIP	0.0033uF	10% 50V
C505	1-165-176-11	CERAMIC CHIP	0.047uF	10% 16V
C506	1-107-823-11	CERAMIC CHIP	0.47uF	10% 16V
C507	1-107-826-11	CERAMIC CHIP	0.1uF	10% 16V
C508	1-164-230-11	CERAMIC CHIP	220PF	5% 50V
C509	1-164-360-11	CERAMIC CHIP	0.1uF	16V
C510	1-164-217-11	CERAMIC CHIP	150PF	5% 50V
C511	1-164-217-11	CERAMIC CHIP	150PF	5% 50V
C512	1-162-963-11	CERAMIC CHIP	680PF	10% 50V
C513	1-162-963-11	CERAMIC CHIP	680PF	10% 50V
C514	1-126-391-11	ELECT CHIP	47uF	20% 6.3V
C515	1-164-360-11	CERAMIC CHIP	0.1uF	16V
C516	1-162-974-11	CERAMIC CHIP	0.01uF	50V
C517	1-164-360-11	CERAMIC CHIP	0.1uF	16V
C518	1-164-360-11	CERAMIC CHIP	0.1uF	16V
C519	1-164-360-11	CERAMIC CHIP	0.1uF	16V
C520	1-164-360-11	CERAMIC CHIP	0.1uF	16V
C521	1-164-360-11	CERAMIC CHIP	0.1uF	16V
C522	1-164-360-11	CERAMIC CHIP	0.1uF	16V
C550	1-164-360-11	CERAMIC CHIP	0.1uF	16V
C553	1-164-360-11	CERAMIC CHIP	0.1uF	16V
C554	1-164-360-11	CERAMIC CHIP	0.1uF	16V
< CONNECTOR >				
CN1	1-764-616-12	HOUSING, CONNECTOR (PC BOARD) 30P		
CN2	1-794-153-21	CONNECTOR, FPC (ZIF) 16P		
CN3	1-770-347-21	CONNECTOR, FPC 6P		
< JUMPER RESISTOR >				
FB101	1-216-295-11	SHORT	0	
FB102	1-216-295-11	SHORT	0	
FB503	1-216-295-11	SHORT	0	
< IC >				
IC1	8-752-095-36	IC CXA2596M-T6		
IC5	8-752-914-87	IC CXP84640-072Q		
IC7	8-759-832-99	IC LA6576L-TE-L		
IC501	8-752-392-04	IC CXD2598Q		
< JUMPER RESISTOR >				
JR501	1-216-295-11	SHORT	0	
JR505	1-216-864-11	SHORT	0	

CDX-CA850/CA850X/CA860X

SERVO **SUB** **SUB (CD)**

Ref. No.	Part No.	Description	Remark
JR506	1-216-864-11	SHORT 0	
		< TRANSISTOR >	
Q101	8-729-904-87	TRANSISTOR 2SB1197K-T-146-R	
		< RESISTOR >	
R101	1-216-847-11	METAL CHIP 150K 5%	1/16W
R102	1-216-847-11	METAL CHIP 150K 5%	1/16W
R103	1-216-801-11	METAL CHIP 22 5%	1/16W
R104	1-216-857-11	METAL CHIP 1M 5%	1/16W
R105	1-216-833-11	METAL CHIP 10K 5%	1/16W
R106	1-216-857-11	METAL CHIP 1M 5%	1/16W
R107	1-216-835-11	METAL CHIP 15K 5%	1/16W
R108	1-216-838-11	METAL CHIP 27K 5%	1/16W
R109	1-216-801-11	METAL CHIP 22 5%	1/16W
R110	1-216-843-11	METAL CHIP 68K 5%	1/16W
R111	1-216-842-11	METAL CHIP 56K 5%	1/16W
R113	1-216-839-11	METAL CHIP 33K 5%	1/16W
R122	1-216-845-11	METAL CHIP 100K 5%	1/16W
R123	1-216-839-11	METAL CHIP 33K 5%	1/16W
R127	1-216-821-11	METAL CHIP 1K 5%	1/16W
R213	1-216-821-11	METAL CHIP 1K 5%	1/16W
R301	1-216-843-11	METAL CHIP 68K 5%	1/16W
R302	1-216-839-11	METAL CHIP 33K 5%	1/16W
R303	1-216-821-11	METAL CHIP 1K 5%	1/16W
R304	1-216-839-11	METAL CHIP 33K 5%	1/16W
R306	1-216-833-11	METAL CHIP 10K 5%	1/16W
R307	1-216-833-11	METAL CHIP 10K 5%	1/16W
R308	1-216-833-11	METAL CHIP 10K 5%	1/16W
R309	1-216-833-11	METAL CHIP 10K 5%	1/16W
R310	1-216-833-11	METAL CHIP 10K 5%	1/16W
R311	1-216-833-11	METAL CHIP 10K 5%	1/16W
R312	1-216-845-11	METAL CHIP 100K 5%	1/16W
R313	1-216-842-11	METAL CHIP 56K 5%	1/16W
R314	1-216-842-11	METAL CHIP 56K 5%	1/16W
R315	1-216-842-11	METAL CHIP 56K 5%	1/16W
R316	1-216-842-11	METAL CHIP 56K 5%	1/16W
R317	1-216-838-11	METAL CHIP 27K 5%	1/16W
R318	1-216-842-11	METAL CHIP 56K 5%	1/16W
R319	1-216-842-11	METAL CHIP 56K 5%	1/16W
R320	1-216-833-11	METAL CHIP 10K 5%	1/16W
R321	1-216-846-11	METAL CHIP 120K 5%	1/16W
R322	1-216-835-11	METAL CHIP 15K 5%	1/16W
R501	1-216-833-11	METAL CHIP 10K 5%	1/16W
R503	1-216-845-11	METAL CHIP 100K 5%	1/16W
R504	1-216-857-11	METAL CHIP 1M 5%	1/16W
R505	1-216-839-11	METAL CHIP 33K 5%	1/16W
R506	1-216-845-11	METAL CHIP 100K 5%	1/16W
R507	1-216-827-11	METAL CHIP 3.3K 5%	1/16W
R511	1-216-845-11	METAL CHIP 100K 5%	1/16W
R513	1-216-827-11	METAL CHIP 3.3K 5%	1/16W
R516	1-216-845-11	METAL CHIP 100K 5%	1/16W

Ref. No.	Part No.	Description	Remark
R517	1-216-837-11	METAL CHIP 22K 5%	1/16W
R518	1-216-834-11	METAL CHIP 12K 5%	1/16W
R519	1-216-834-11	METAL CHIP 12K 5%	1/16W
R520	1-216-834-11	METAL CHIP 12K 5%	1/16W
R521	1-216-834-11	METAL CHIP 12K 5%	1/16W
R522	1-216-834-11	METAL CHIP 12K 5%	1/16W
R523	1-216-834-11	METAL CHIP 12K 5%	1/16W
R524	1-216-845-11	METAL CHIP 100K 5%	1/16W
R526	1-216-845-11	METAL CHIP 100K 5%	1/16W
R527	1-216-845-11	METAL CHIP 100K 5%	1/16W
R531	1-216-809-11	METAL CHIP 100 5%	1/16W
R532	1-216-845-11	METAL CHIP 100K 5%	1/16W
R533	1-216-845-11	METAL CHIP 100K 5%	1/16W
R535	1-216-845-11	METAL CHIP 100K 5%	1/16W
R551	1-216-841-11	METAL CHIP 47K 5%	1/16W
R552	1-216-841-11	METAL CHIP 47K 5%	1/16W
R553	1-216-845-11	METAL CHIP 100K 5%	1/16W
R554	1-216-845-11	METAL CHIP 100K 5%	1/16W
R555	1-216-845-11	METAL CHIP 100K 5%	1/16W
R558	1-216-864-11	SHORT 0	
R560	1-216-809-11	METAL CHIP 100 5%	1/16W
R563	1-216-809-11	METAL CHIP 100 5%	1/16W
R564	1-216-845-11	METAL CHIP 100K 5%	1/16W
R568	1-216-837-11	METAL CHIP 22K 5%	1/16W
R569	1-216-809-11	METAL CHIP 100 5%	1/16W
R570	1-216-821-11	METAL CHIP 1K 5%	1/16W
R572	1-216-809-11	METAL CHIP 100 5%	1/16W
R590	1-216-845-11	METAL CHIP 100K 5%	1/16W
R594	1-216-845-11	METAL CHIP 100K 5%	1/16W
R595	1-216-845-11	METAL CHIP 100K 5%	1/16W
R599	1-216-821-11	METAL CHIP 1K 5%	1/16W
		< VIBRATOR >	
X1	1-781-758-21	VIBRATOR, CERAMIC (CHIP TYPE) (10MHz)	
X2	1-781-759-21	VIBRATOR, CERAMIC (CHIP TYPE) (16MHz)	

*	1-659-834-11	SUB BOARD	

		< CONNECTOR >	
CN1	1-770-347-21	CONNECTOR, FPC 6P	

*	1-680-868-11	SUB (CD) BOARD	

		< CAPACITOR >	
C852	1-162-960-11	CERAMIC CHIP 220PF 10%	50V
C853	1-162-960-11	CERAMIC CHIP 220PF 10%	50V

Ref. No.	Part No.	Description	Remark
		< CONNECTOR >	
CN852	1-794-064-12	SOCKET, CONNECTOR 14P	
		< DIODE >	
D851	8-719-078-81	DIODE DF5A6.8FU(TE85R)	
D852	8-719-078-81	DIODE DF5A6.8FU(TE85R)	
LED851	8-719-082-38	LED CL-270SR-C-TS (INSERT MARK)	
		< SWITCH >	
LSW851	1-771-883-11	SWITCH, TACTILE (WITH LED) (▲)	
		< RESISTOR >	
R855	1-219-286-11	METAL CHIP 680 2% 1/16W	
R856	1-219-286-11	METAL CHIP 680 2% 1/16W	

MISCELLANEOUS

9	1-776-207-72	CORD (WITH CONNECTOR) (POWER) (CA850X/CA860X)
9	1-776-527-71	CORD (WITH CONNECTOR) (ISO) (POWER) (CA850)
24	1-792-195-11	CABLE, FLEXIBLE FLAT (14 CORE)
201	X-3378-598-1	CHASSIS (OP) ASSY (including M901)
207	1-659-880-11	MOTOR FLEXIBLE BOARD
△ 210	8-820-103-03	PICK-UP, OPTICAL KSS-720A/K1RP
212	1-676-707-21	PICK-UP FLEXIBLE BOARD
F901	1-532-877-11	FUSE (BLADE TYPE) (AUTO FUSE) 10A
M902	A-3291-674-A	MOTOR ASSY, SLED (SLED)
M903	A-3315-039-A	MOTOR SUB ASSY, LD (LOADING)

ACCESSORIES & PACKING MATERIALS

1-476-546-31	REMOTE COMMANDER (RM-X113) (CA850)
1-476-546-41	REMOTE COMMANDER (RM-X112) (CA850X/CA860X)
1-476-589-11	REMOTE COMMANDER (RM-X5S)
3-020-953-01	LABEL (MODE) (for RM-X5S)
3-229-196-11	MANUAL, INSTRUCTION (ENGLISH,FRENCH, DUTCH,ITALIAN,GERMAN) (CA850)
3-229-196-21	MANUAL, INSTRUCTION (ENGLISH,SPANISH, SWEDISH,PORTUGUESE,GREEK,RUSSIAN)
3-229-198-11	MANUAL, INSTRUCTION (ENGLISH,FRENCH, SPANISH) (CA850X/CA860X)
3-229-199-11	MANUAL, INSTRUCTION, INSTALL (ENGLISH, FRENCH,SPANISH) (CA850X/CA860X)
3-229-200-11	MANUAL, INSTRUCTION, INSTALL (ENGLISH, FRENCH,DUTCH,ITALIAN,GERMAN) (CA850)
3-229-200-21	MANUAL, INSTRUCTION, INSTALL (ENGLISH, SPANISH,SWEDISH,PORTUGUESE, GREEK,RUSSIAN)
3-230-549-01	LID, BATTERY CASE (for RM-X112/X113)
X-3378-490-1	CASE (PANEL) ASSY (for FRONT PANEL)

Ref. No.	Part No.	Description	Remark
		***** HARDWARE LIST *****	
#1	7-685-790-01	SCREW +PTT 2.6X4 (S)	
#2	7-685-792-09	SCREW +PTT 2.6X6 (S)	
#3	7-621-772-20	SCREW +B 2X5	
#4	7-685-646-79	SCREW +BVTP 3X8 TYPE2 N-S	
#5	7-685-794-09	SCREW +PTT 2.6X10 (S)	
#6	7-685-793-09	SCREW +PTT 2.6X8 (S)	
#7	7-685-797-09	SCREW +PTT 2.6X16 (S)	
#8	7-685-105-19	SCREW +P 2X8 TYPE2 NON-SLIT	
#9	7-627-553-37	SCREW, PRECISION +P 2X3 TYPE3	
#10	7-627-553-17	SCREW, PRECISION +P 2X2 TYPE3	
#11	7-628-253-00	SCREW +PS 2X4	
#12	7-627-850-28	SCREW, PRECISION +P 1.4X3	
#13	7-628-253-15	SCREW +PS 2X5	

PARTS FOR INSTALLATION AND CONNECTIONS

251	X-3373-602-1	FRAME ASSY
252	3-386-828-01	SCREW, FITTING (CA850)
253	3-349-410-01	BUSHING (CA850)
254	X-3366-405-1	SCREW ASSY (EXP), FITTING (CA850)
255	3-924-961-01	SUPPORT (ND), FITTING (CA850X/CA860X)
256	7-682-160-01	SCREW +P 4X6 (CA850X/CA860X)
257	X-3368-725-1	SCREW ASSY, FITTING (CA850X/CA860X)
258	3-040-979-01	COLLAR
259	3-934-325-01	SCREW, +K (5X8) TAPPING
260	1-465-459-21	ADAPTOR, ANTENNA (CA850)
261	3-041-000-01	SPRING, FITTING
262	1-776-207-72	CORD (WITH CONNECTOR) (POWER) (CA850X/CA860X)
263	1-776-527-71	CORD (WITH CONNECTOR) (ISO) (POWER) (CA850)
264	7-685-248-14	SCREW +KTP 3X12 TYPE4 (for RM-X5S)
265	3-231-381-01	STRAP (ROTARY COMMANDER) (for RM-X5S)
* 266	3-671-893-00	CLAMP (LOW TYPE) (for RM-X5S)
267	X-3373-432-1	BRACKET ASSY (for RM-X5S)

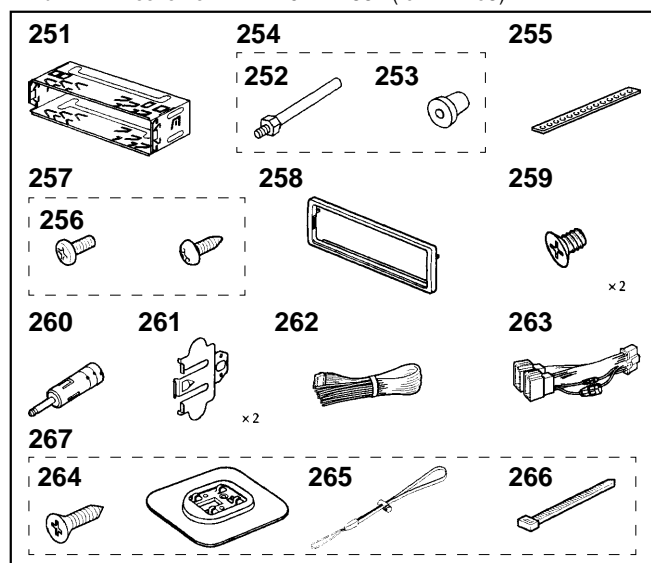

The components identified by mark ▲ or dotted line with mark ▲ are critical for safety. Replace only with part number specified.

Les composants identifiés par une marque ▲ sont critiques pour la sécurité. Ne les remplacer que par une pièce portant le numéro spécifié.

