

CDX-L510X

SERVICE MANUAL

Ver 1.1 2003. 06

US Model
Canadian Model



- The tuner and CD sections have no adjustments.

AUDIO POWER SPECIFICATIONS (US Model)

POWER OUTPUT AND TOTAL HARMONIC DISTORTION
23.2 watts per channel minimum continuous average power into
4 ohms, 4 channels driven from 20 Hz to 20 kHz with no more
than 5% total harmonic distortion.

CD player section

Signal-to-noise ratio 90 dB
Frequency response 10 – 20,000 Hz
Wow and flutter Below measurable limit

Tuner section

FM
Tuning range 87.5 – 107.9 MHz
Antenna terminal External antenna connector
Intermediate frequency 10.7 MHz
Usable sensitivity 11 dBf
Selectivity 75 dB at 400 kHz
Signal-to-noise ratio 65 dB (stereo),
68 dB (mono)
Harmonic distortion at 1 kHz
0.7% (stereo),
0.5% (mono)
Separation 33 dB at 1 kHz
Frequency response 30 – 15,000 Hz

AM

Tuning range 530 – 1,710 kHz
Antenna terminal External antenna connector
Intermediate frequency 10.7 MHz/450 kHz
Sensitivity AM: 30 μ V

Power amplifier section

Outputs Speaker outputs
(sure seal connectors)
Speaker impedance 4 – 8 ohms
Maximum power output 50 W \times 4 (at 4 ohms)

Model Name Using Similar Mechanism	CDX-L280
CD Drive Mechanism Type	MG-393XC-121//K
Optical Pick-up Name	KSS-721A

SPECIFICATIONS

General

Outputs Audio outputs (rear)
Power antenna relay control terminal
Power amplifier control terminal
Inputs Remote controller input terminal
Antenna input terminal
Tone controls Low: ± 10 dB at 60 Hz (XPLOD)
Mid: ± 10 dB at 1 kHz (XPLOD)
High: ± 10 dB at 10 kHz (XPLOD)
Power requirements 12 V DC car battery
(negative ground)
Dimensions Approx. 178 \times 50 \times 180 mm
(7 1/8 \times 2 \times 7 1/8 in.) (w/h/d)
Mounting dimensions Approx. 182 \times 53 \times 161 mm
(7 1/4 \times 2 1/8 \times 6 3/8 in.) (w/h/d)
Mass Approx. 1.2 kg
(2 lb. 10 oz.)
Supplied accessories Parts for installation and connections
Front panel case (1)
Card remote commander
RM-X115

Note

This unit cannot be connected to a digital preamplifier or an equalizer.

Design and specifications are subject to change without notice.

FM/AM COMPACT DISC PLAYER

9-874-231-02

2003F04-1

© 2003. 06

Sony Corporation

e Vehicle Company

Published by Sony Engineering Corporation

SONY®

SERVICE NOTES

NOTES ON HANDLING THE OPTICAL PICK-UP BLOCK OR BASE UNIT

The laser diode in the optical pick-up block may suffer electrostatic breakdown because of the potential difference generated by the charged electrostatic load, etc. on clothing and the human body. During repair, pay attention to electrostatic breakdown and also use the procedure in the printed matter which is included in the repair parts. The flexible board is easily damaged and should be handled with care.

NOTES ON LASER DIODE EMISSION CHECK

The laser beam on this model is concentrated so as to be focused on the disc reflective surface by the objective lens in the optical pick-up block. Therefore, when checking the laser diode emission, observe from more than 30 cm away from the objective lens.

Notes on Chip Component Replacement

- Never reuse a disconnected chip component.
- Notice that the minus side of a tantalum capacitor may be damaged by heat.

CAUTION

Use of controls or adjustments or performance of procedures other than those specified herein may result in hazardous radiation exposure.

If the optical pick-up block is defective, please replace the whole optical pick-up block.
Never turn the semi-fixed resistor located at the side of optical pick-up block.

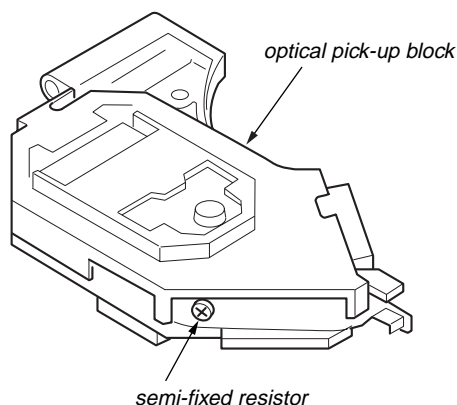

TEST DISCS

This set can playback CD-R and CD-ROM discs. The following test discs should be used to check the capability:

- CD-R test disc TCD-R082LMT (Part No. J-2502-063-1)
- CD-RW test disc TCD-W082L (Part No. J-2502-063-2)

Notes on CD-R/CD-RW discs

- You can play CD-Rs (recordable CDs)/CD-RWs (rewritable CDs) designed for audio use on this unit.
Look for these marks to distinguish CD-Rs/CD-RWs for audio use.



These marks denote that a disc is not for audio use.



- Some CD-Rs/CD-RWs (depending on the equipment used for its recording or the condition of the disc) may not play on this unit.
- You cannot play a CD-R/CD-RW that is not finalized*.

* A process necessary for a recorded CD-R/CD-RW disc to be played on the audio CD player.

SAFETY-RELATED COMPONENT WARNING!!

COMPONENTS IDENTIFIED BY MARK \triangle OR DOTTED LINE WITH MARK \triangle ON THE SCHEMATIC DIAGRAMS AND IN THE PARTS LIST ARE CRITICAL TO SAFE OPERATION. REPLACE THESE COMPONENTS WITH SONY PARTS WHOSE PART NUMBERS APPEAR AS SHOWN IN THIS MANUAL OR IN SUPPLEMENTS PUBLISHED BY SONY.

ATTENTION AU COMPOSANT AYANT RAPPORT À LA SÉCURITÉ!!

LES COMPOSANTS IDENTIFIÉS PAR UNE MARQUE \triangle SUR LES DIAGRAMMES SCHÉMATIQUES ET LA LISTE DES PIÈCES SONT CRITIQUES POUR LA SÉCURITÉ DE FONCTIONNEMENT. NE REMPLACER CES COMPOSANTS QUE PAR DES PIÈCES SONY DONT LES NUMÉROS SONT DONNÉS DANS CE MANUEL OU DANS LES SUPPLÉMENTS PUBLIÉS PAR SONY.

TABLE OF CONTENTS

1. GENERAL

Location of controls 4
 Connections 4

2. DISASSEMBLY

2-1. Sub Panel Assy (CD) 6
 2-2. CD Mechanism Block 7
 2-3. Main Board 7
 2-4. Heat Sink 8
 2-5. Chassis (T) Sub Assy 8
 2-6. Lever Section, In Self Sw Board 9
 2-7. Servo Board 9
 2-8. Shaft Roller Assy, Load Sw Board 10
 2-9. Floating Block Assy 10
 2-10. Optical Pick-up Block 11

3. DIAGRAMS

3-1. IC Pin Description 12
 3-2. Circuit Boards Location 14
 3-3. Block Diagram –CD Section– 15
 3-4. Block Diagram –Tuner Section– 16
 3-5. Block Diagram –Display Section– 17
 3-6. Printed Wiring Boards –CD Mechanism Section– 18
 3-7. Schematic Diagram –CD Mechanism Section– 20
 3-8. Printed Wiring Boards –Main Section– 21
 3-9. Schematic Diagram –Main Section (1/2)– 22
 3-10. Schematic Diagram –Main Section (2/2)– 23
 3-11. Printed Wiring Board –Relay Section– 24
 3-12. Printed Wiring Board –Display Section– 25
 3-13. Schematic Diagram –Display, Relay Section– 26
 3-14. IC Block Diagrams 27

4. EXPLODED VIEWS

4-1. Chassis Section 30
 4-2. Front panel Section 31
 4-3. CD Mechanism Section (1) 32
 4-4. CD Mechanism Section (2) 33
 4-5. CD Mechanism Section (3) 34

5. ELECTRICAL PARTS LIST 35

EXTENSION CABLE AND SERVICE POSITION

When repairing or servicing this set, connect the jig (extension cable) as shown below.

- Connect the MAIN board (CNP701) and the SERVO board (CN1) with the extension cable (Part No. J-2502-062-1).

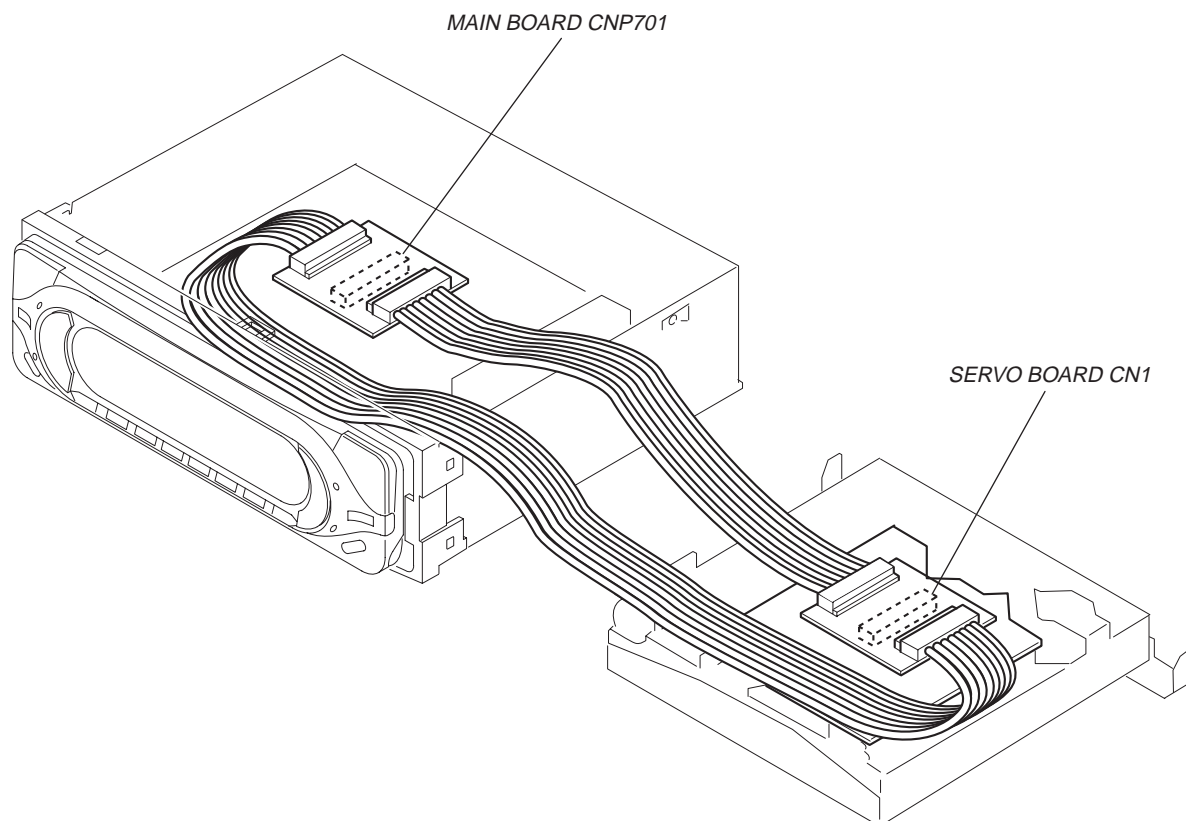

This section is extracted from instruction manual.

Location of controls

Refer to the pages listed for details.

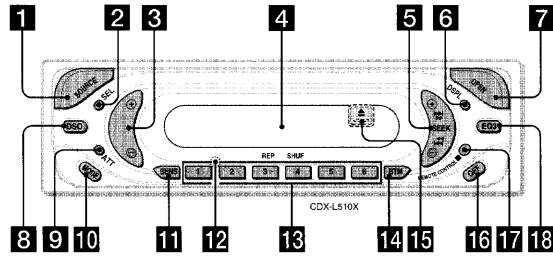

- | | |
|--|---|
| <p>1 SOURCE (Power on/Radio/CD) button
Selecting the source.</p> <p>2 SEL (select) button
Selecting items.</p> <p>3 Volume +/- button</p> <p>4 Display window</p> <p>5 SEEK +/- button
Radio:
Tuning in stations automatically/finding a station manually.
CD:
Skipping tracks/fast-forwarding, reversing a track.</p> <p>6 DSPL (display mode change) button
8, 9</p> <p>7 OPEN button 7, 9</p> <p>8 DSO button 14</p> <p>9 ATT (attenuate) button 13</p> <p>10 MODE button
Changing the operation.</p> <p>11 SENS button 11</p> <p>12 RESET button (located on the front side of the unit, behind the front panel) 7</p> | <p>13</p> <p>14 BTM (Best Tuning Memory) button 10</p> <p>15 ▲ (eject) button (located on the front side of the unit, behind the front panel) 9</p> <p>16 OFF (Stop/Power off) button* 7, 9</p> <p>17 Receptor for the card remote commander</p> <p>18 EQ3 button 14</p> <p>* Warning when installing in a car without an ACC (accessory) position on the ignition switch
After turning off the ignition, be sure to press and hold OFF on the unit until the display disappears.
Otherwise, the display does not turn off and this causes battery drain.</p> |
|--|---|

Card remote commander RM-X115

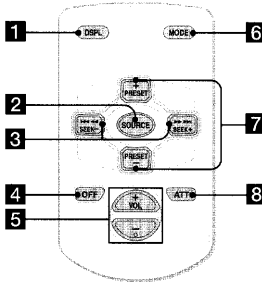

The corresponding buttons of the card remote commander control the same functions as those on this unit.

- 1 DSPL button
- 2 SOURCE button
- 3 SEEK (+/-) buttons
- 4 OFF button
- 5 VOL (+/-) buttons
- 6 MODE button
- 7 PRESET (+/-) buttons
- 8 ATT button

Note
If the display disappears by pressing **OFF**, it cannot be operated with the card remote commander unless **SOURCE** on the unit is pressed, or a disc is inserted to activate the unit first.

Tip
Refer to "Replacing the lithium battery" for details on how to replace the batteries (page 15).

Precautions

- If your car has been parked in direct sunlight, allow the unit to cool off before operating it.
- Power antenna will extend automatically while the unit is operating.

If you have any questions or problems concerning your unit that are not covered in this manual, please consult your nearest Sony dealer.

Moisture condensation

On a rainy day or in a very damp area, moisture condensation may occur inside the lenses and display of the unit. Should this occur, the unit will not operate properly. In such a case, remove the disc and wait for about an hour until the moisture has evaporated.

To maintain high sound quality

Be careful not to splash juice or other soft drinks onto the unit or discs.

Connections

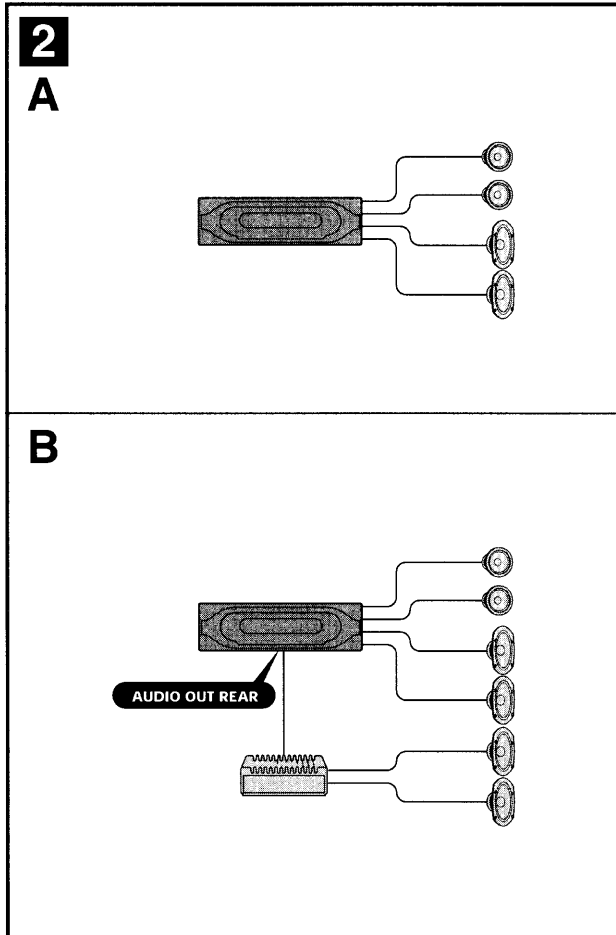

Connection example (2)

- Notes (2-B)**
- Be sure to connect the ground cord before connecting the amplifier.
 - If you connect an optional power amplifier and do not use the built-in amplifier, the beep sound will be deactivated.

Exemple de raccordement (2)

- Remarques (2-B)**
- Raccordez d'abord le fil de masse avant de raccorder l'amplificateur.
 - Si vous raccordez un amplificateur de puissance en option et que vous n'utilisez pas l'amplificateur intégré, le bip sonore est désactivé.

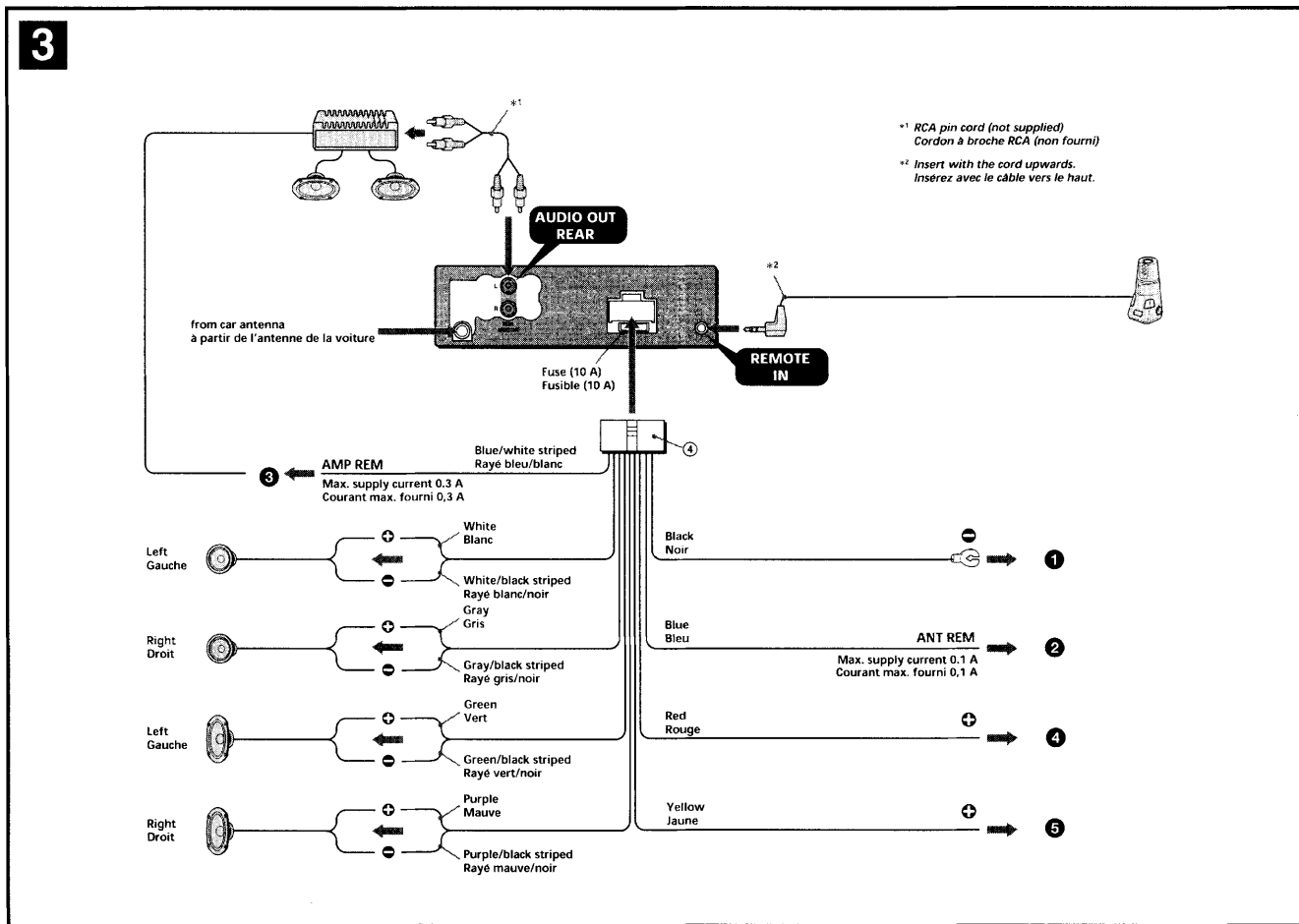

*1 RCA pin cord (not supplied)
Cordon à broche RCA (non fourni)
** Insert with the cord upwards.
Insérez avec le câble vers le haut.

Connection diagram (3)

- 1 To a metal surface of the car
First connect the black ground lead, then connect the yellow and red power input leads.
- 2 To the power antenna control lead or power supply lead of antenna booster amplifier
Notes
• It is not necessary to connect this lead if there is no power antenna or antenna booster, or with a manually-operated telescopic antenna.
• When your car has a built-in FM/AM antenna in the rear/side glass, see "Notes on the control and power supply leads."
- 3 To AMP REMOTE IN of an optional power amplifier
This connection is only for amplifiers. Connecting any other system may damage the unit.
- 4 To the +12 V power terminal which is energized in the accessory position of the ignition key switch
Notes
• If there is no accessory position, connect to the +12 V power (battery) terminal which is energized at all times.
Be sure to connect the black ground lead to a metal surface of the car first.
• When your car has a built-in FM/AM antenna in the rear/side glass, see "Notes on the control and power supply leads."
- 5 To the +12 V power terminal which is energized at all times
Be sure to connect the black ground lead to a metal surface of the car first.

Notes on the control and power supply leads

- The power antenna control lead (blue) supplies +12 V DC when you turn on the tuner.
- When your car has built-in FM/AM antenna in the rear/side glass, connect the power antenna control lead (blue) or the accessory power input lead (red) to the power terminal of the existing antenna booster. For details, consult your dealer.
- A power antenna without relay box cannot be used with this unit.

Memory hold connection

When the yellow power input lead is connected, power will always be supplied to the memory circuit even when the ignition key is turned off.

Notes on speaker connection

- Before connecting the speakers, turn the unit off.
- Use speakers with an impedance of 4 to 8 ohms, and with adequate power handling capacities to avoid its damage.
- Do not connect the speaker terminals to the car chassis, or connect the terminals of the right speakers with those of the left speaker.
- Do not connect the ground lead of this unit to the negative (-) terminal of the speaker.
- Do not attempt to connect the speakers in parallel.
- Connect only passive speakers. Connecting active speakers (with built-in amplifiers) to the speaker terminals may damage the unit.
- To avoid a malfunction, do not use the built-in speaker wires installed in your car if the unit shares a common negative (-) lead for the right and left speakers.
- Do not connect the unit's speaker cords to each other.

Schéma de raccordement (3)

- 1 À un point métallique de la voiture
Branchez d'abord le fil de masse noir et, ensuite, les fils d'entrée d'alimentation jaune et rouge.
- 2 Vers le fil de commande de l'antenne électrique ou le fil d'alimentation de l'amplificateur d'antenne
Remarques
• Il n'est pas nécessaire de raccorder ce fil s'il n'y a pas d'antenne électrique ni d'amplificateur d'antenne, ou avec une antenne télescopique manuelle.
• Si votre voiture est équipée d'une antenne FM/AM intégrée dans la vitre arrière/latérale, voir "Remarques sur les fils de commande et d'alimentation".
- 3 Au niveau du AMP REMOTE IN de l'amplificateur de puissance en option
Ce raccordement s'applique uniquement aux amplificateurs. Le branchement de tout autre système risque d'endommager l'appareil.
- 4 À la borne +12 V qui est alimentée quand la clé de contact est sur la position accessoires
Remarques
• S'il n'y a pas de position accessoires, raccordez la borne d'alimentation (batterie) +12 V qui est alimentée en permanence.
Raccordez d'abord le fil de masse noir à un point métallique de la voiture.
• Si votre voiture est équipée d'une antenne FM/AM intégrée dans la vitre arrière/latérale, voir "Remarques sur les fils de commande et d'alimentation".
- 5 À la borne +12 V qui est alimentée en permanence
Raccordez d'abord le fil de masse noir à un point métallique de la voiture.

Remarques sur les fils de commande et d'alimentation

- Le fil de commande de l'antenne électrique (bleu) fournit une alimentation de +12 V CC lorsque vous mettez la radio sous tension.
- Lorsque votre voiture est équipée d'une antenne FM/AM intégrée dans la vitre arrière/latérale, raccordez la sortie de commande de l'antenne (bleu) ou l'entrée d'alimentation des accessoires (rouge) à la borne de l'amplificateur d'antenne existant. Pour plus de détails, consultez votre détaillant.
- Une antenne électrique sans boîtier de relais ne peut pas être utilisée avec cet appareil.

Raccordement pour la conservation de la mémoire

Lorsque le fil d'entrée d'alimentation jaune est raccorder, le circuit de la mémoire est alimenté en permanence même si la clé de contact est sur la position d'arrêt.

Remarques sur le raccordement des haut-parleurs

- Avant de raccorder les haut-parleurs, mettez l'appareil hors tension.
- Utilisez des haut-parleurs ayant une impédance de 4 à 8 ohms avec une capacité électrique adéquate pour éviter de les endommager.
- Ne raccordez pas les bornes du système de haut-parleur au châssis de la voiture et ne raccordez pas les bornes du haut-parleur droit à celles du haut-parleur gauche.
- Ne raccordez pas le câble de masse de cet appareil à la borne négative (-) de l'enceinte.
- N'essayez pas de raccorder les haut-parleurs en parallèle.
- Raccordez uniquement des haut-parleurs passifs. Le raccordement de haut-parleurs actifs (avec amplificateurs intégrés) aux bornes des haut-parleurs peut endommager l'appareil.
- Pour éviter tout dysfonctionnement, n'utilisez pas les fils des haut-parleurs intégrés installés dans votre voiture si l'appareil partage un fil négatif commun (-) pour les haut-parleurs droit et gauche.
- Ne raccordez pas entre eux les cordons des haut-parleurs de l'appareil.

SECTION 2 DISASSEMBLY

Note : This set can be disassemble according to the following sequence.

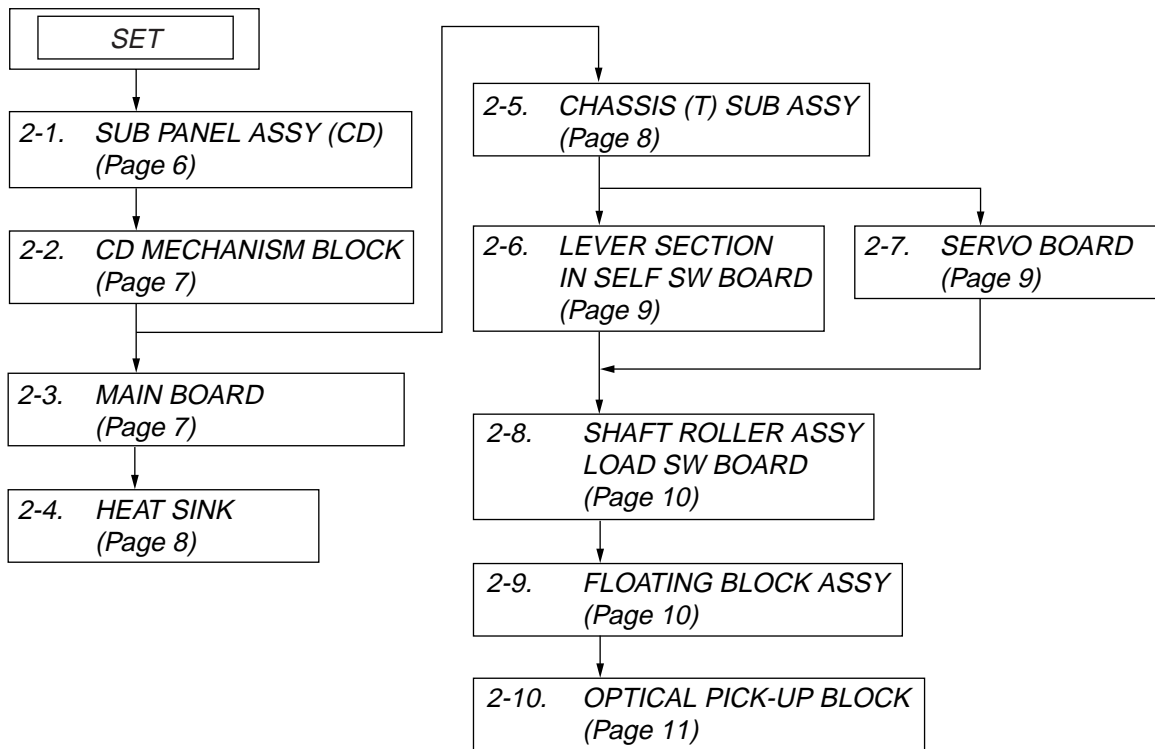

Note : Follow the disassembly procedure in the numerical order given.

2-1. SUB PANEL ASSY (CD)

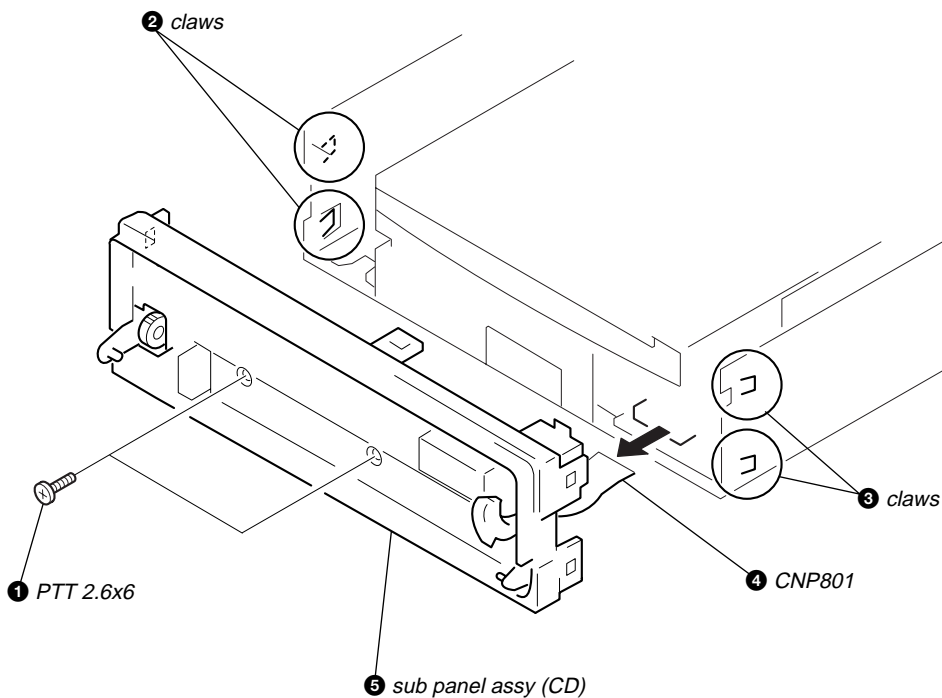

2-2. CD MECHANISM BLOCK

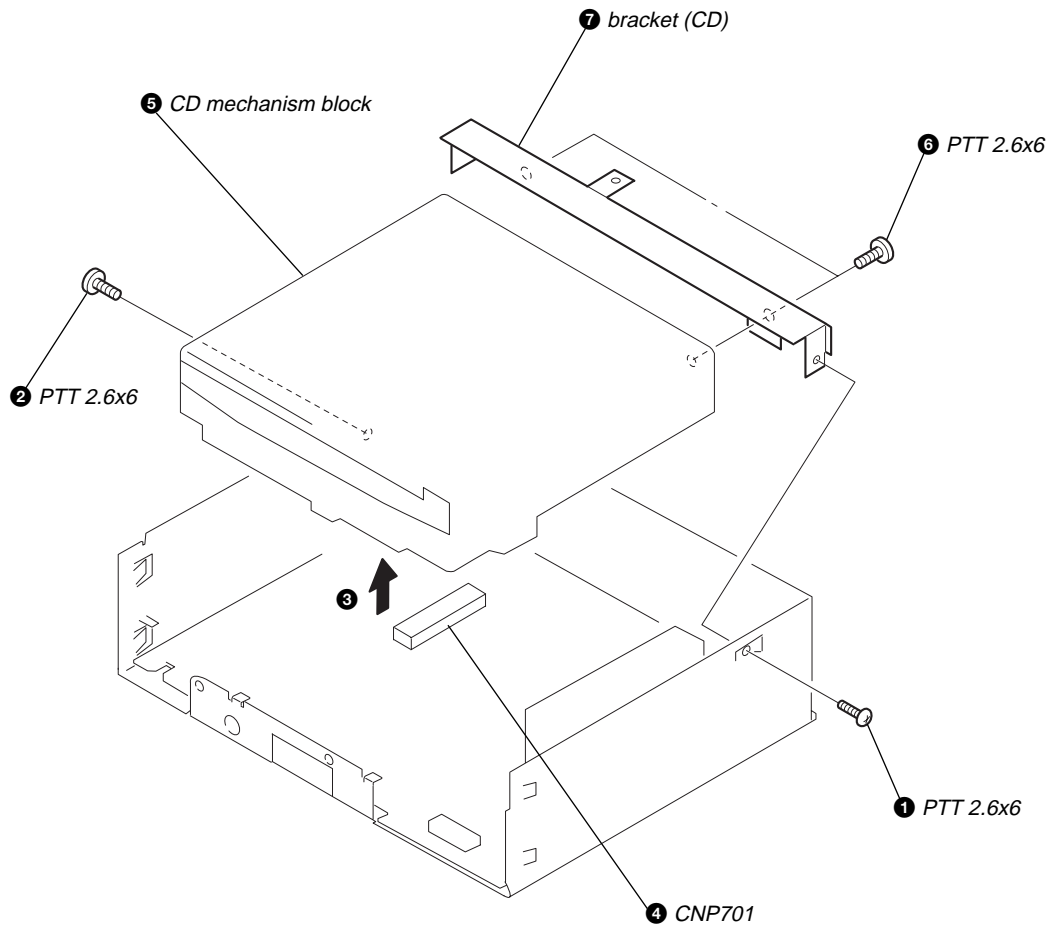

2-3. MAIN BOARD

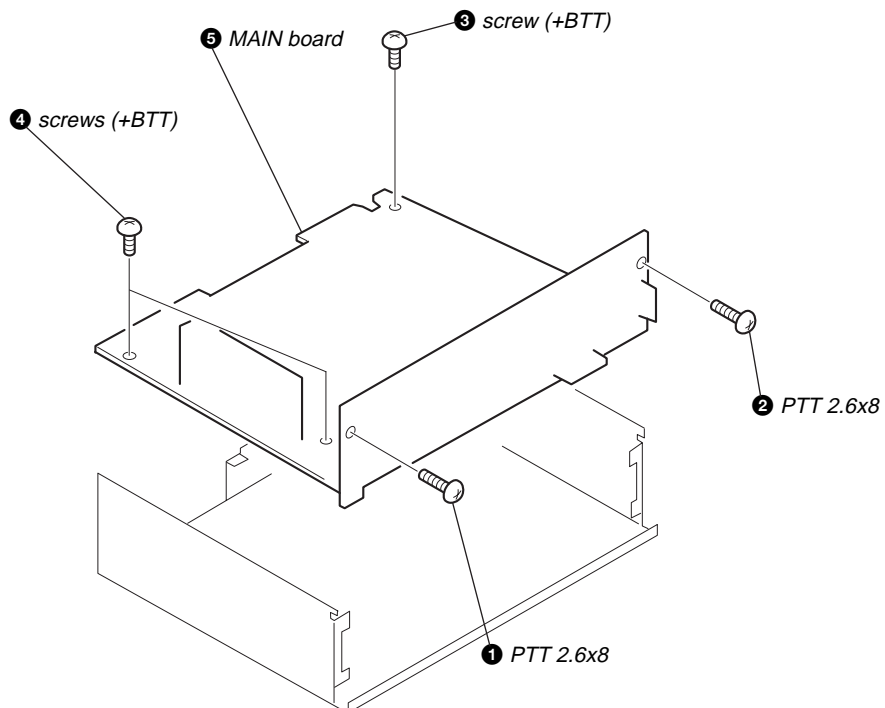

2-4. HEAT SINK

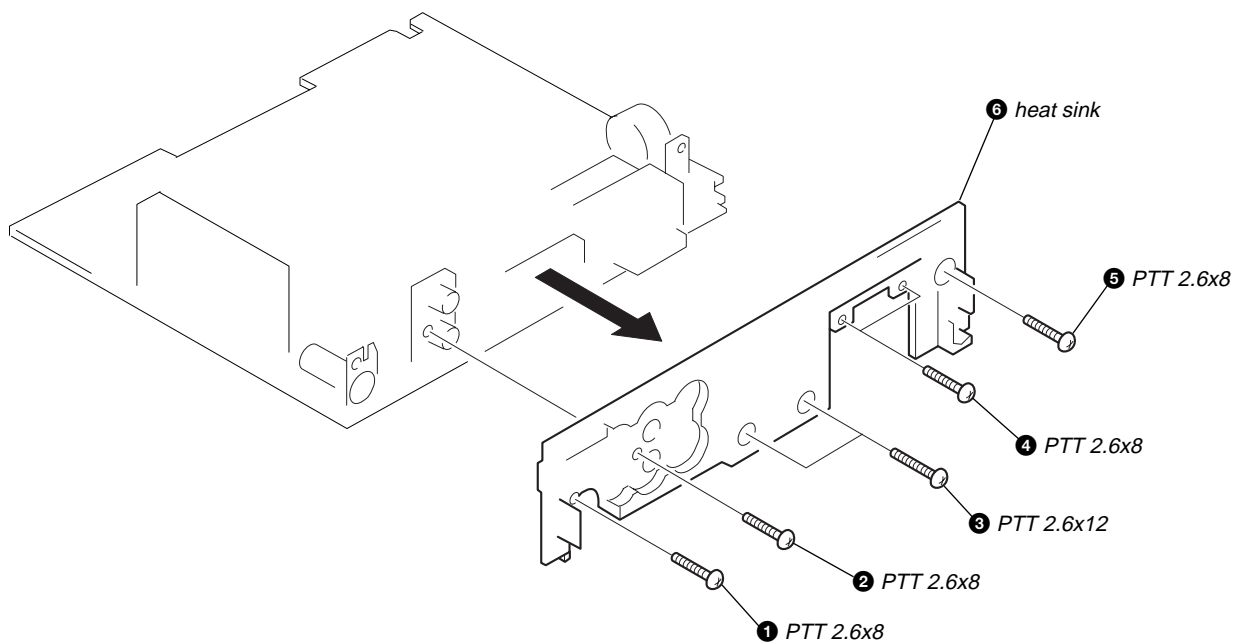

2-5. CHASSIS (T) SUB ASSY

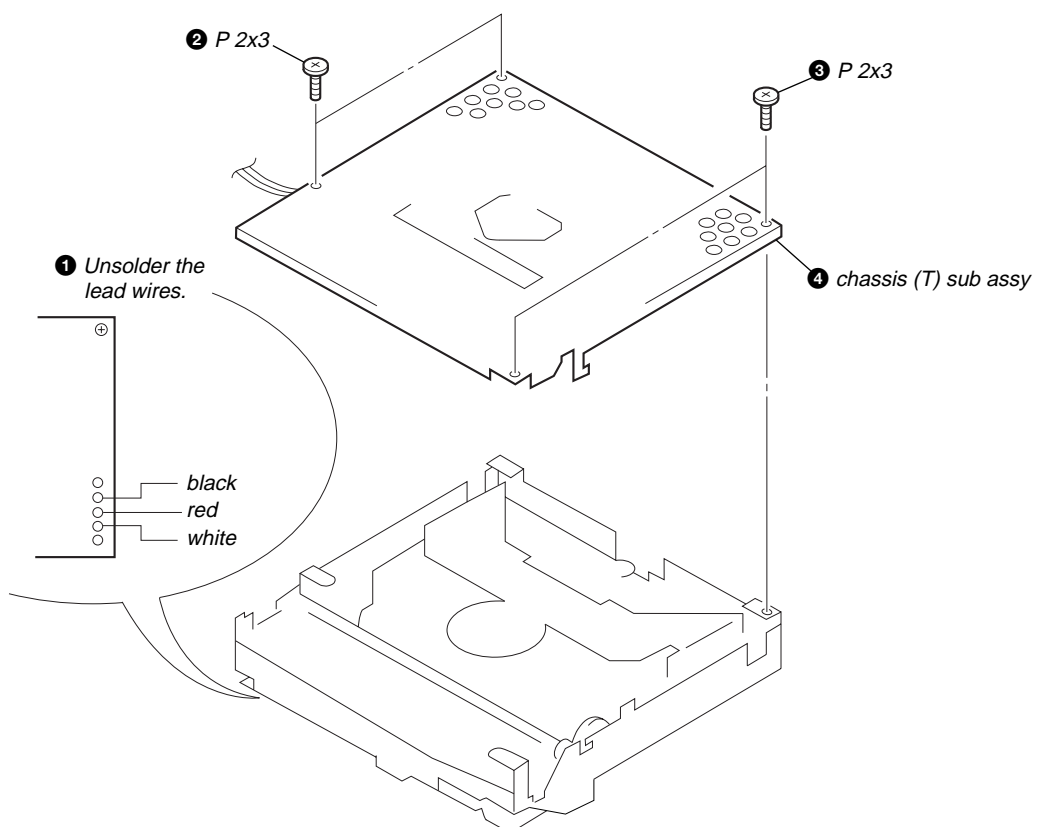

2-6. LEVER SECTION, IN SELF SW BOARD

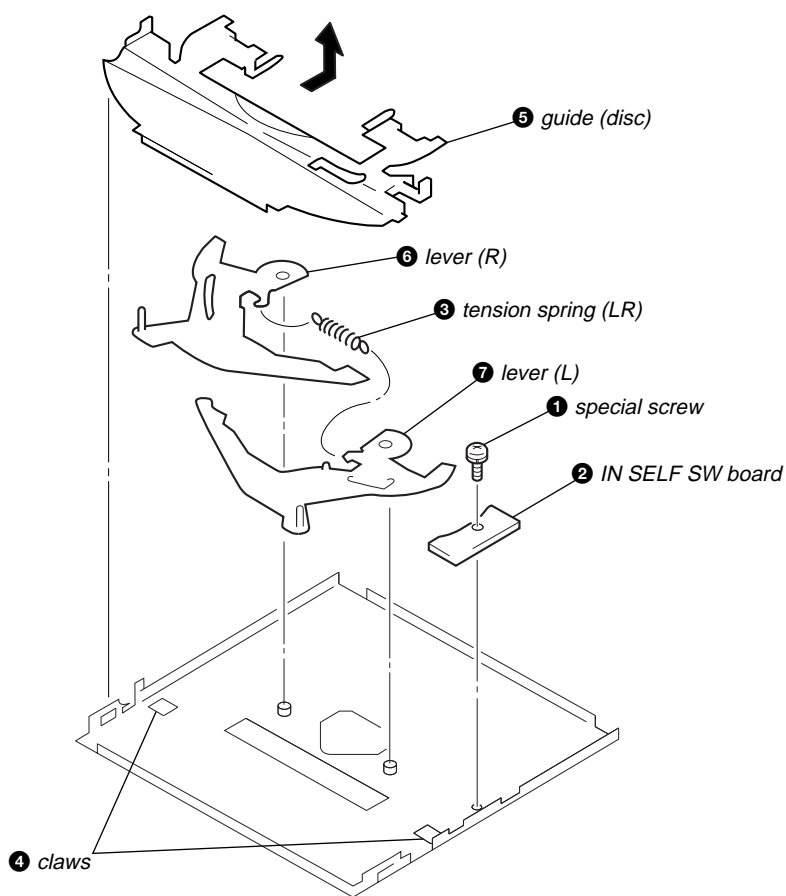

2-7. SERVO BOARD

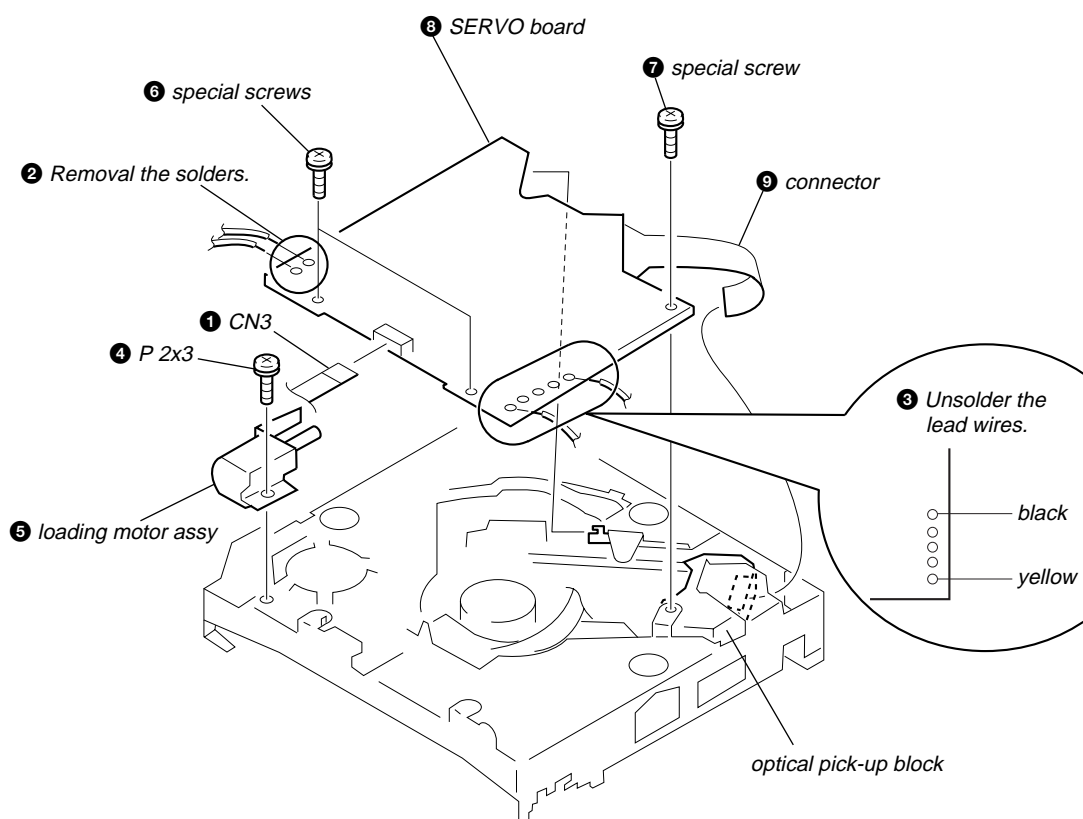

2-8. SHAFT ROLLER ASSY, LOAD SW BOARD

- When installing, take note of the positions arm (roller) and washers. (Fig. 1)

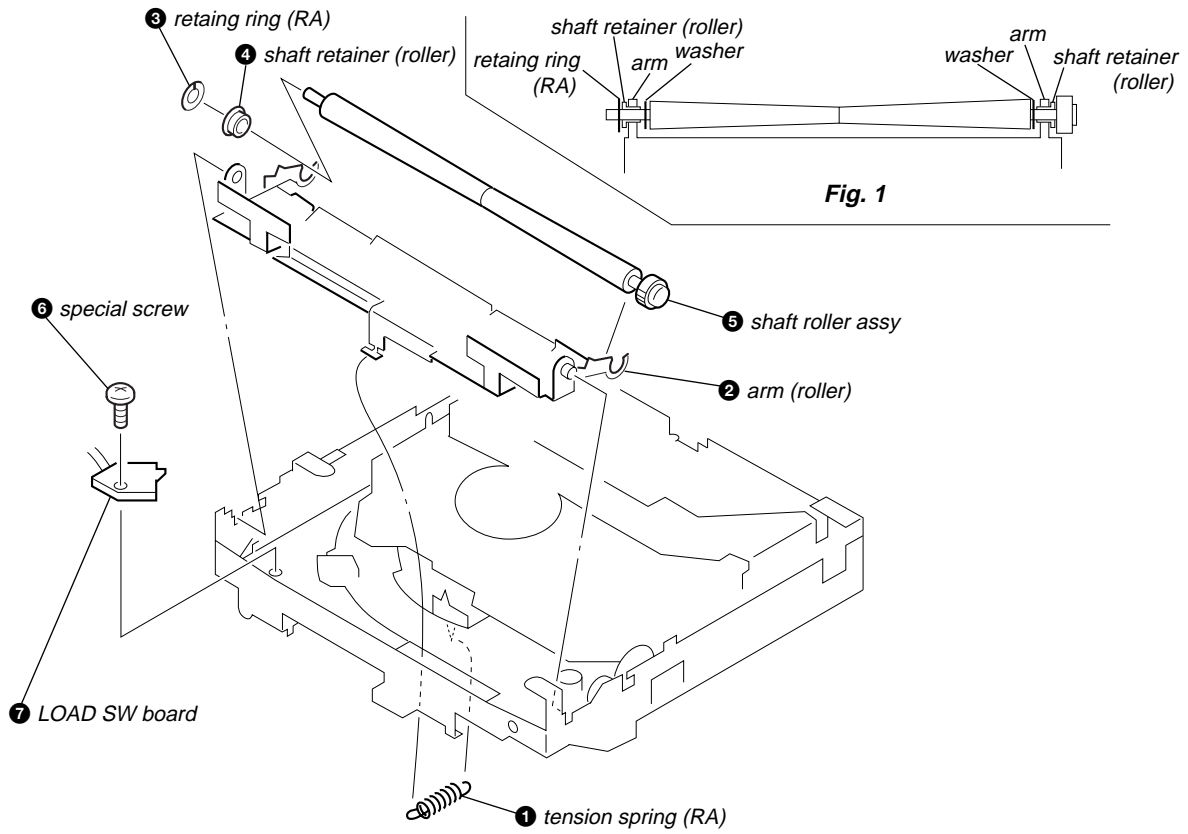

2-9. FLOATING BLOCK ASSY

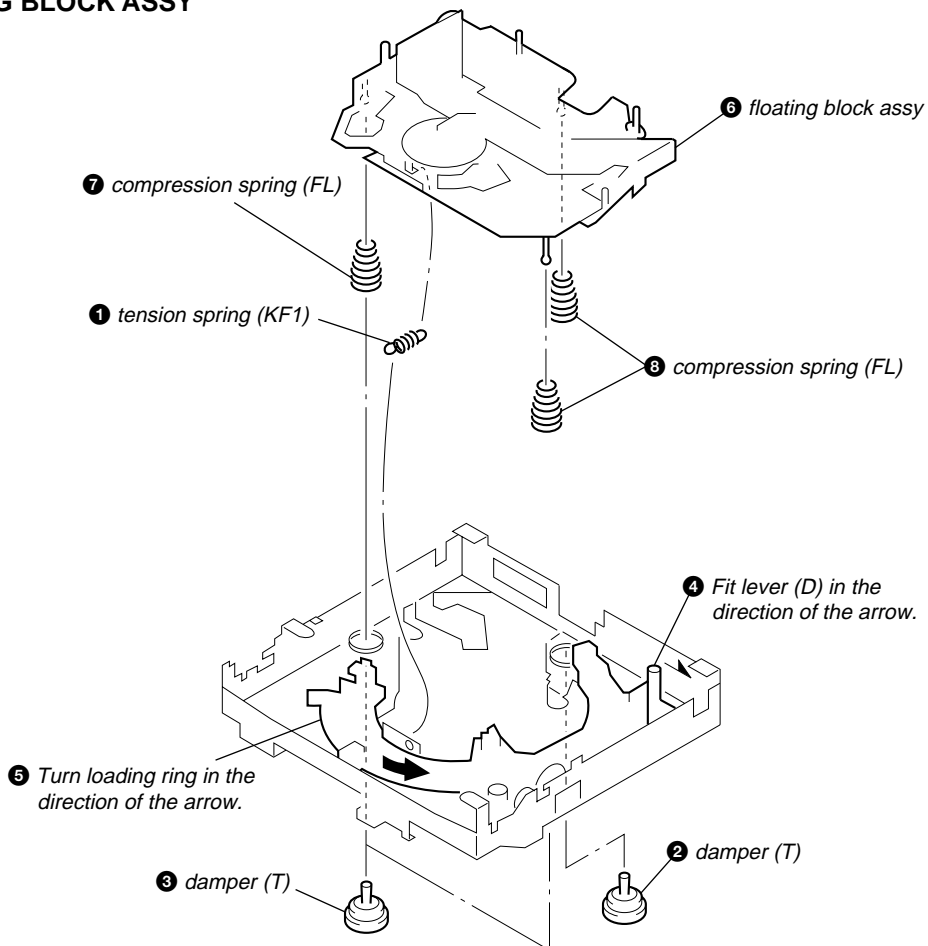

2-10. OPTICAL PICK-UP BLOCK

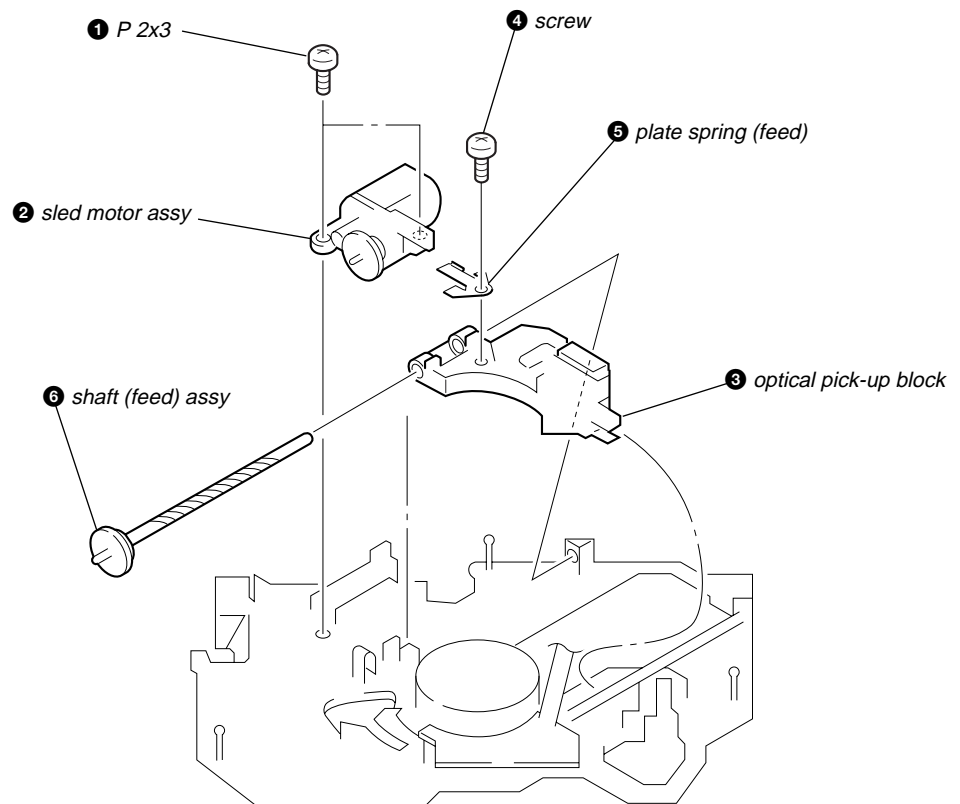

SECTION 3 DIAGRAMS

3-1. IC PIN DESCRIPTION

• IC801 μ PD780076YGK-R24 (SYSTEM CONTROL) (MAIN Board)

Pin No.	Pin Name	I/O	Pin Description
1	D SW	I	Down switch detection signal input "L": Down switch on
2	LM LD	O	Loading motor drive control signal output (Loading direction)
3	LM EJ	O	Loading motor drive control signal output (Eject direction)
4	ATT	O	Mute control signal output of audio signal line "H": mute on
5	$\overline{A ATT}$	O	Mute control signal output to power amp IC (IC101) "L": amp mute on
6	PLL DI	I	Serial data signal input to PLL IC (IC601)
7	$\overline{VOL ATT}$	O	Mute control signal output to Electric volume IC (IC401)
8	DOOR SW/IND	I	Door switch signal input Case of flipdown, sense to open condition of door "H": open
9	VSS0	—	Ground pin
10	VDD0	—	Power supply pin
11	PLL CE	O	Chip enable signal output to PLL IC (IC601)
12	BEEP	O	Beep signal output of key beep, caution alarm to power amp IC (IC101)
13	SDAO	O	IIC data line signal output (control to electric volume IC (IC401))
14	SCLO	O	IIC clock line signal output (control to electric volume IC (IC401))
15	LCD CE	O	Chip enable control signal output to LCD driver IC (IC901)
16	LCD DO	O	Serial data signal output to LCD driver IC (IC901)
17	LCD CLK	O	Serial clock signal output to LCD driver IC (IC901)
18	BUS SI	I	SONY bus data signal input
19	BUS SO	O	SONY bus data signal output
20	BUS CLK	I	SONY bus clock signal input
21	BUS CLK GEN	O	SONY bus clock signal output
22	AM ON	O	AM select signal output FM circuit power supply control output of tuner unit (TU601) "H": FM on
23	FM ON	O	FM select signal output FM circuit power supply control output of tuner unit (TU601) "H": FM on
24	VDD1	—	Power supply pin
25	AVSS	—	Ground pin
26	ST IND	I/O	Stereo signal input/monaural control signal output At forced monaural on: "L" output At forced monaural off: input mode, stereo on for "L" input
27	SHIFT/PH1	I	Rotary commander shift key signal input
28	S METER	I	S meter signal input from tuner unit (TU601)
29, 30	KEY0, KEY1	I	A/D key signal input Input of A/D key matrix and front panel attachment decision.
31	R COM	I	Rotary commander AD level signal input Sense to key voltage level of rotary commander
32	DST SEL	I	Destination select input
33	TEST	I	Test mode select signal input "L": test mode
34	AVREF	—	Analog reference voltage pin
35	AD ON	O	LCD INHIBIT signal output
36	\overline{RESET}	I	Reset signal input from reset IC (IC902) "H": reset
37	XT2	—	Connect to sub clock (32.768 kHz)
38	XT1	—	Connect to sub clock (32.768 kHz)
39	IC	—	At on board writer: 12 V power supply pin (usually ground pin)
40	X2	—	Connect to crystal oscillator (8.38 MHz)
41	X1	—	Connect to crystal oscillator (8.38 MHz)
42	VSS1	—	Ground pin
43	KEY ACK	I	Key acknowledge signal input
44	SIRCS	I	Wireless remote control signal input from remote control receiver IC (IC951)
45	$\overline{SELF SW}$	I	SELF switch detection signal input "L": SELF switch on
46	$\overline{BU IN}$	I	Backup power supply detection signal input
47	NOSE	I	Front panel attachment detection signal input from SW801 "L": panel on

Pin No.	Pin Name	I/O	Pin Description
48	ILL ON	O	Front panel illumination power supply control signal output "H": illumination on
49	A REMO	O	External amplifier remote control signal output
50	CDM ON	O	CD mechanism deck power supply control signal output "H": CD power on
51	XCD ON	O	CD DSP power supply control signal output "H": CD power on
52	ACC IN	I	Accessory power supply detection signal input "L": accessory on
53	BUS ON	O	SONY bus on signal output Not used in this set. (open)
54	BUS RST	O	SONY bus reset signal output Not used in this set. (open)
55	PW ON	O	System power supply control signal output
56	X SO PLL SO	O	CD and PLL serial data signal output
57	X SI	I	CD serial data signal input
58	X SCK PLL SCK	O	CD and PLL serial data signal output
59	RF OK	I	CD RF OK signal input
60	CD RST	O	CD reset control signal output
61	IN SW/PH2	I	DISC IN switch detection signal input "L": DISC IN switch on
62	X AO	O	Parameter/command select signal output
63	STB	O	CD strobe signal output
64	L SW	I	LIMIT switch detection signal input "L": LIMIT switch on

3-2. CIRCUIT BOARDS LOCATION

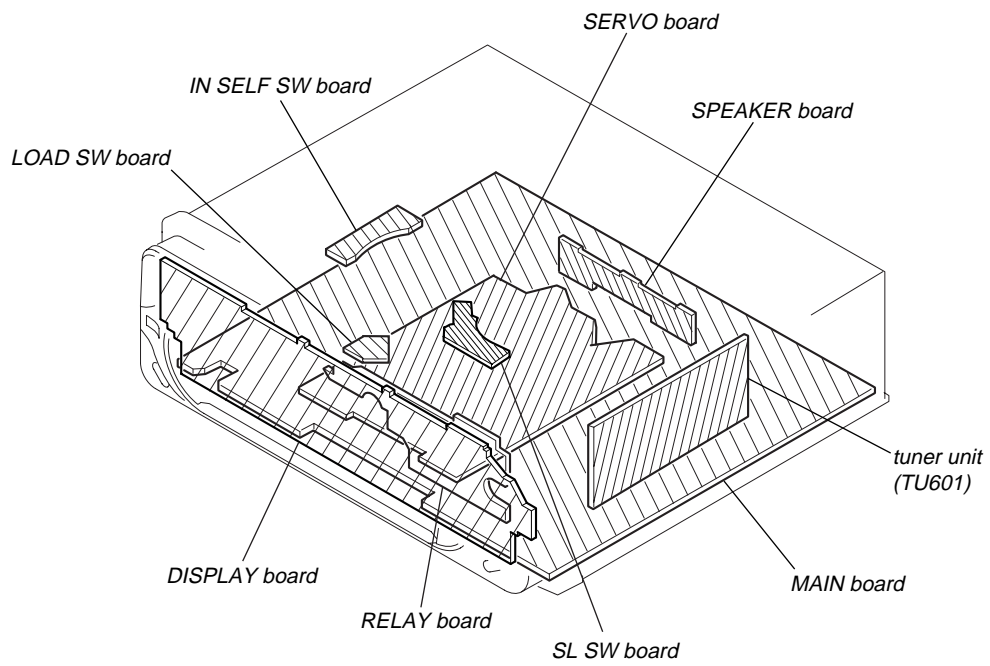

3-3. BLOCK DIAGRAM — CD SECTION —

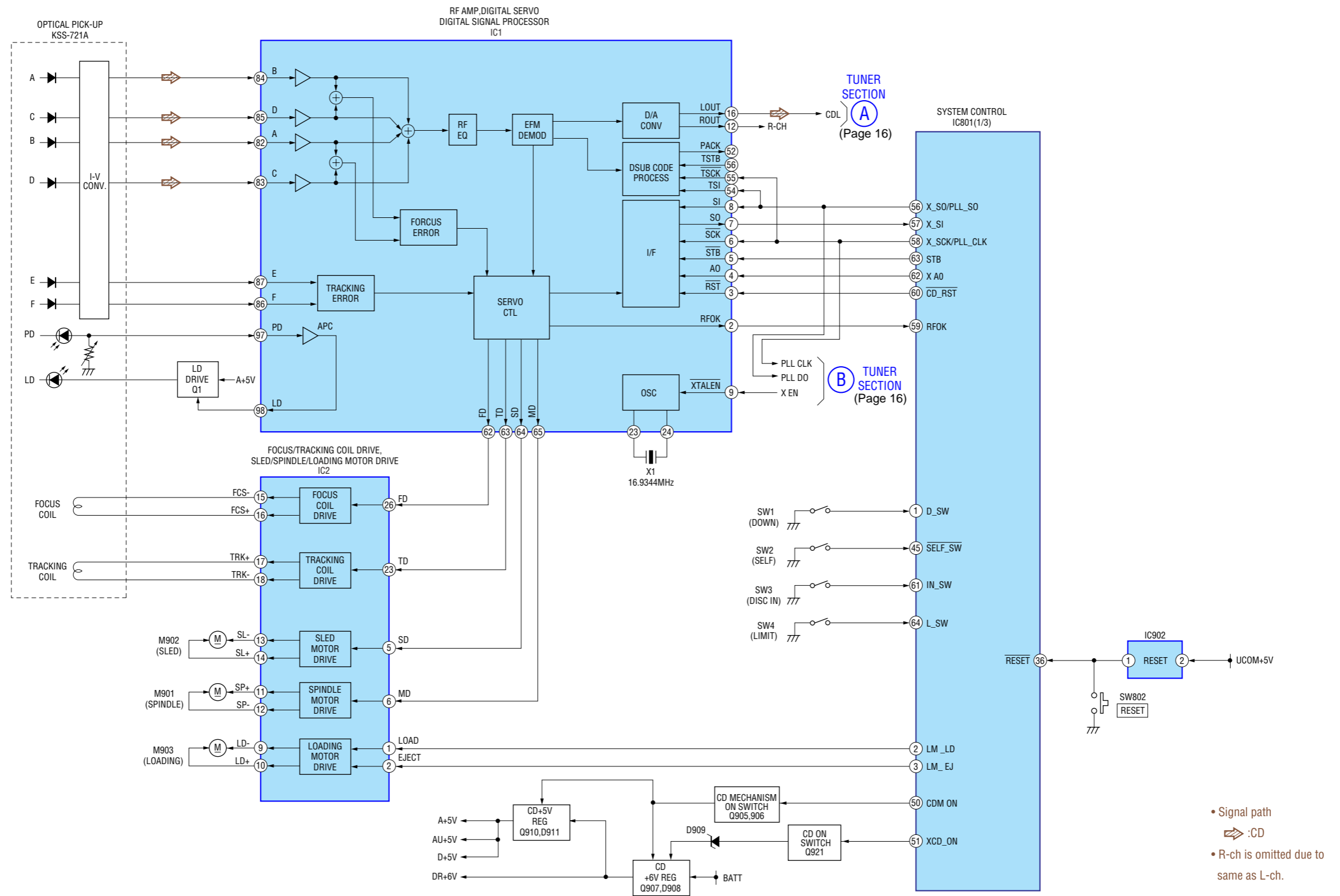

3-4. BLOCK DIAGRAM — TUNER SECTION —

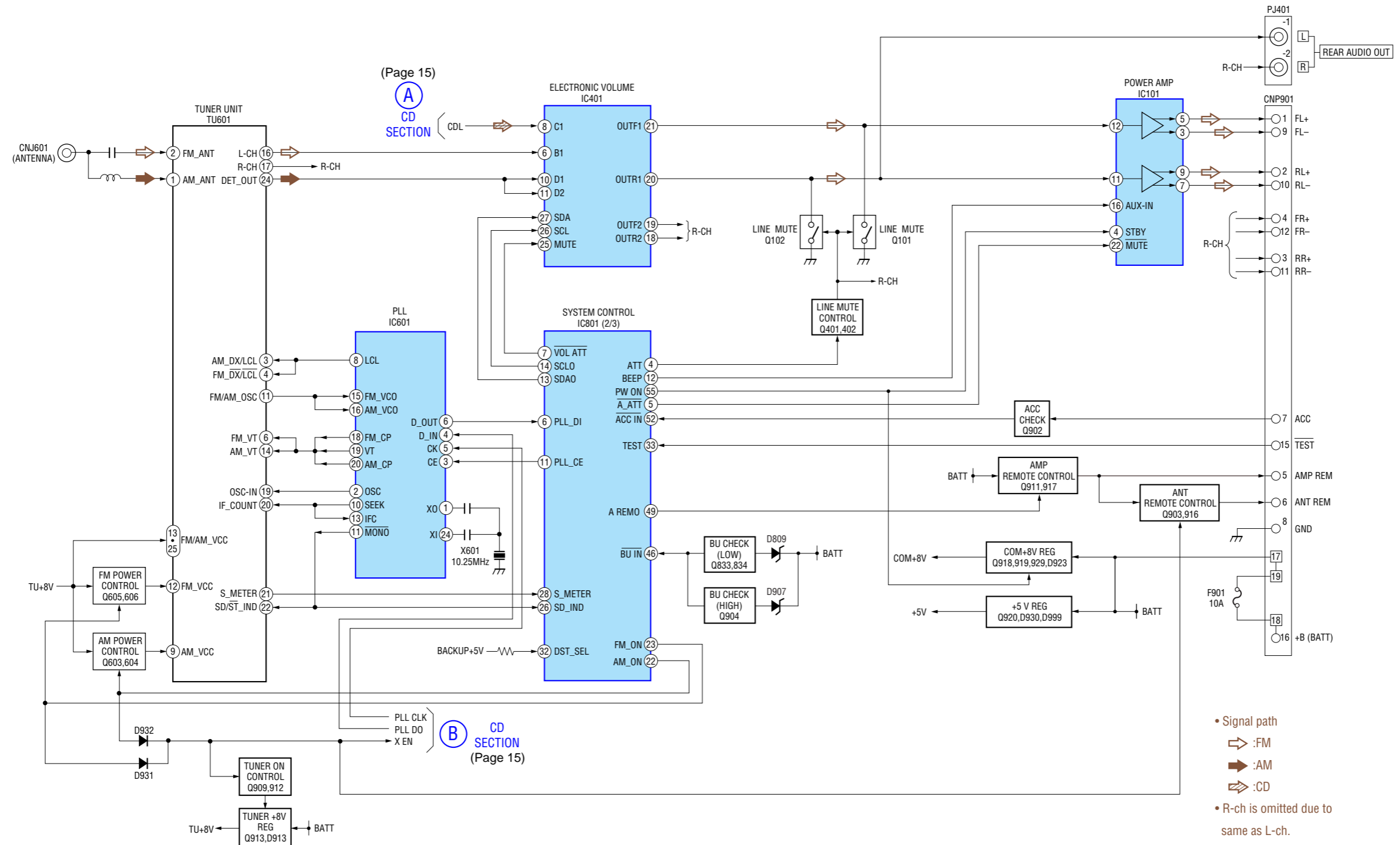

3-5. BLOCK DIAGRAM — DISPLAY SECTION —

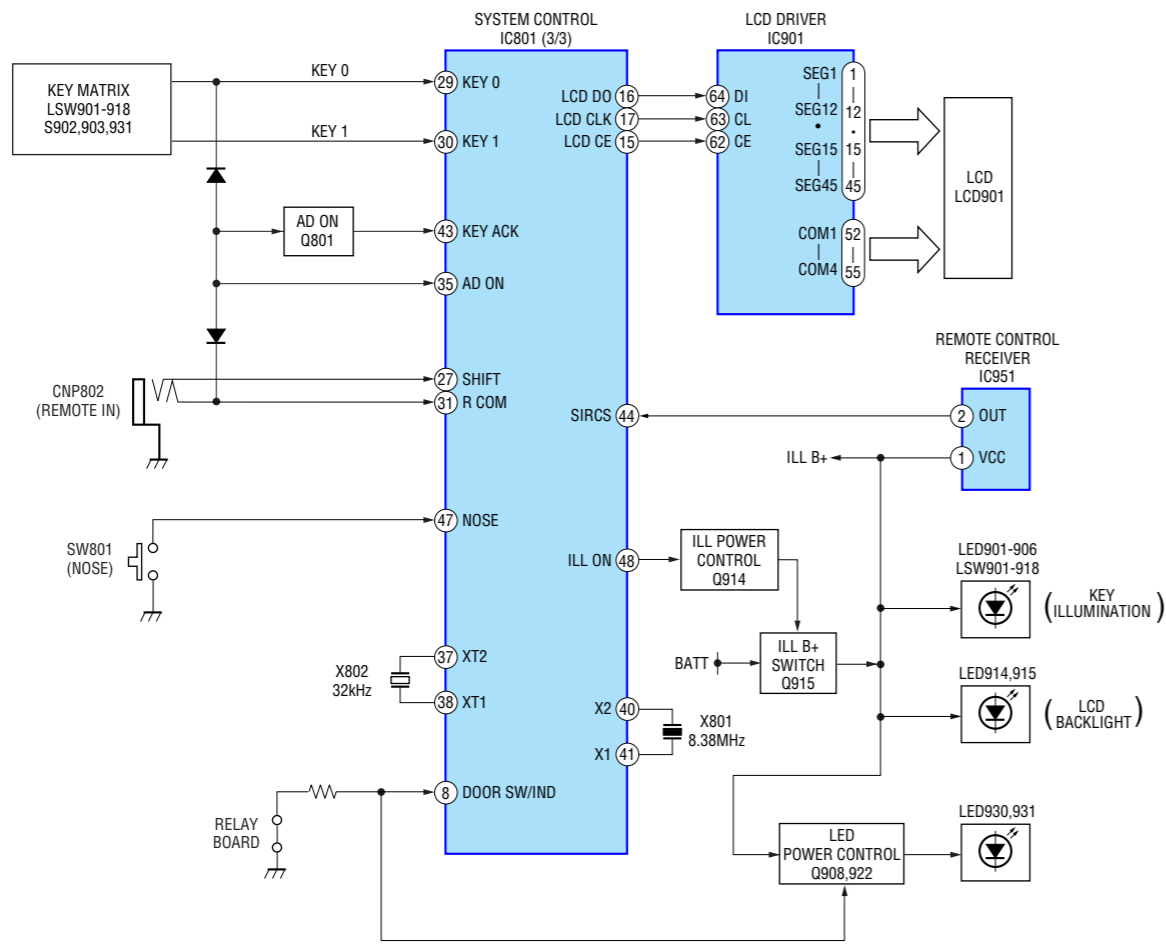

• Waveforms
— Servo Board —
(MODE: CD PLAY)

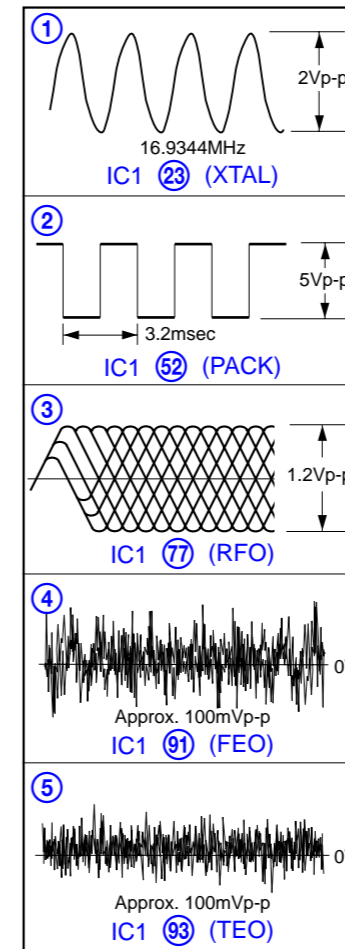

— Main Board —

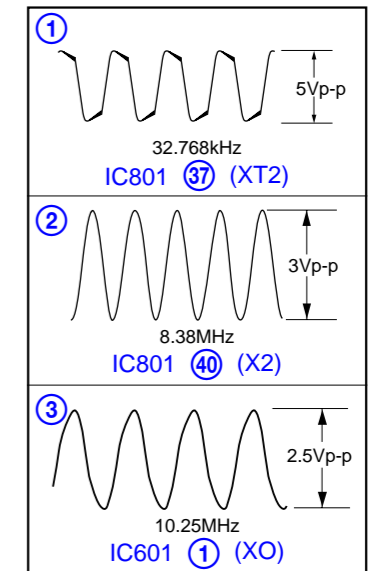

3-6. PRINTED WIRING BOARDS — CD MECHANISM SECTION — • Refer to page 14 for Circuit Boards Location.



OPTICAL PICK-UP
KSS-721A

【PICK-UP FLEXIBLE BOARD】 1-683-284- 11

【SERVO BOARD】
(SIDE B)

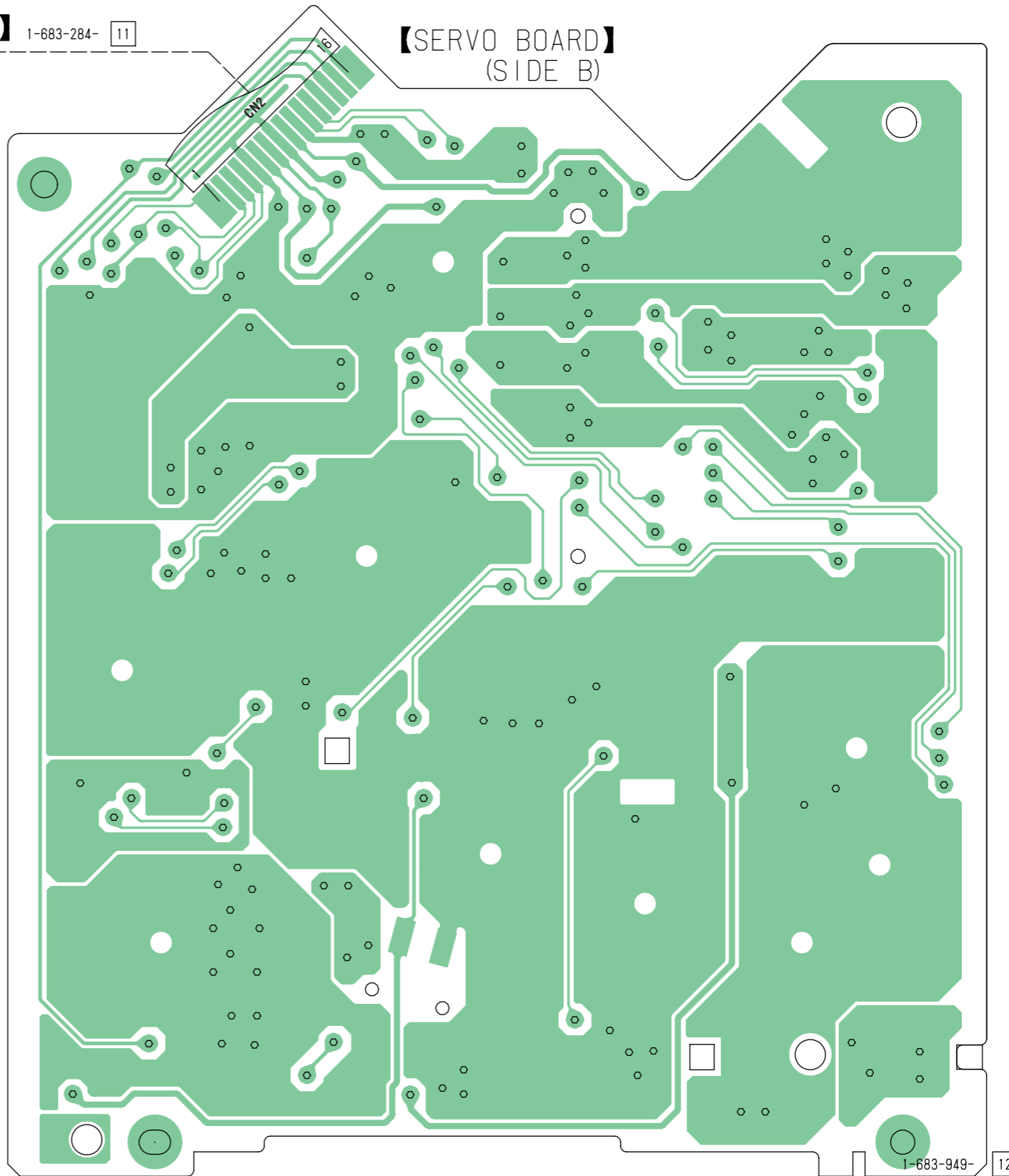

THIS NOTE IS COMMON FOR PRINTED WIRING BOARDS AND SCHEMATIC DIAGRAMS.
(In addition to this, the necessary note is printed in each block.)

for schematic diagram:

- All capacitors are in μF unless otherwise noted. pF: μpF
50 WV or less are not indicated except for electrolytics and tantalums.
- All resistors are in Ω and $1/4\text{W}$ or less unless otherwise specified.
- % : indicates tolerance.
- Δ : internal component.
- : panel designation.

Note:

The components identified by mark Δ or dotted line with mark Δ are critical for safety.
Replace only with part number specified.

Note:

Les composants identifiés par une marque Δ sont critiques pour la sécurité.
Ne les remplacer que par une pièce portant le numéro spécifié.

- — : B+ Line.
- Power voltage is dc 14.4V and fed with regulated dc power supply from ACC and BATT cords.
- Voltages are taken with a VOM (Input impedance 10 M Ω).
Voltage variations may be noted due to normal production tolerances.
- Waveforms are taken with a oscilloscope.
Voltage variations may be noted due to normal production tolerances.
- Circled numbers refer to waveforms.
- Signal path.
- \Rightarrow : FM
- \Rightarrow : AM
- \Rightarrow : CD

for printed wiring boards:

- \circ : parts extracted from the component side.
- --- : parts extracted from the conductor side.
- \blacksquare : parts mounted on the conductor side.
- \circ : Through hole.
- : Pattern from the side which enables seeing.
(The other layer's patterns are not indicated.)

Caution:

Pattern face side: Parts on the pattern face side seen from the (Side B) pattern face are indicated.
Parts face side: Parts on the parts face side seen from the (Side A) parts face are indicated.

A
B
C
D
E
F
G
H
I
J

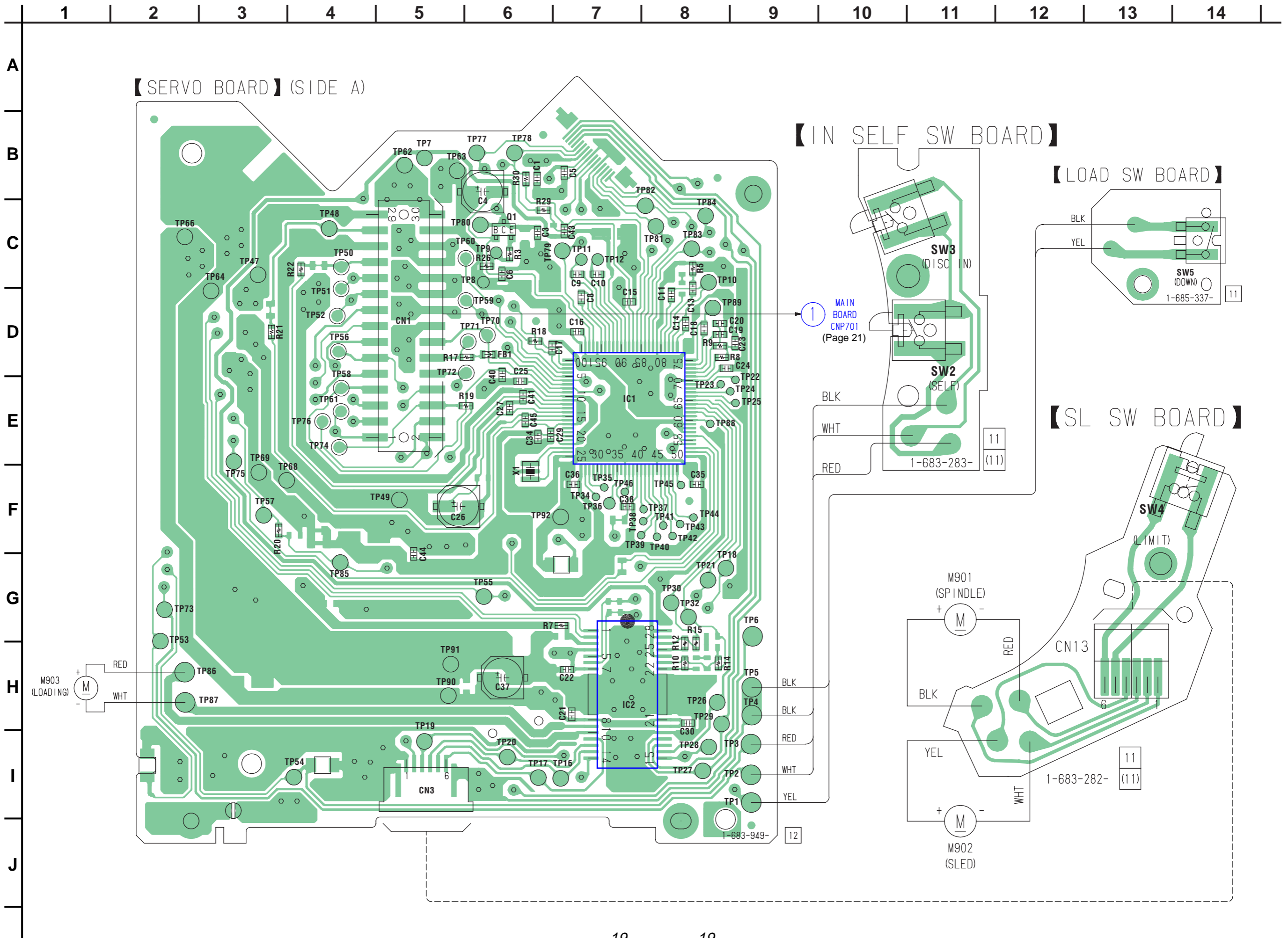

3-7. SCHEMATIC DIAGRAM — CD MECHANISM SECTION —

• Refer to page 17 for Waveforms.

• Refer to page 27 for IC Block Diagrams.

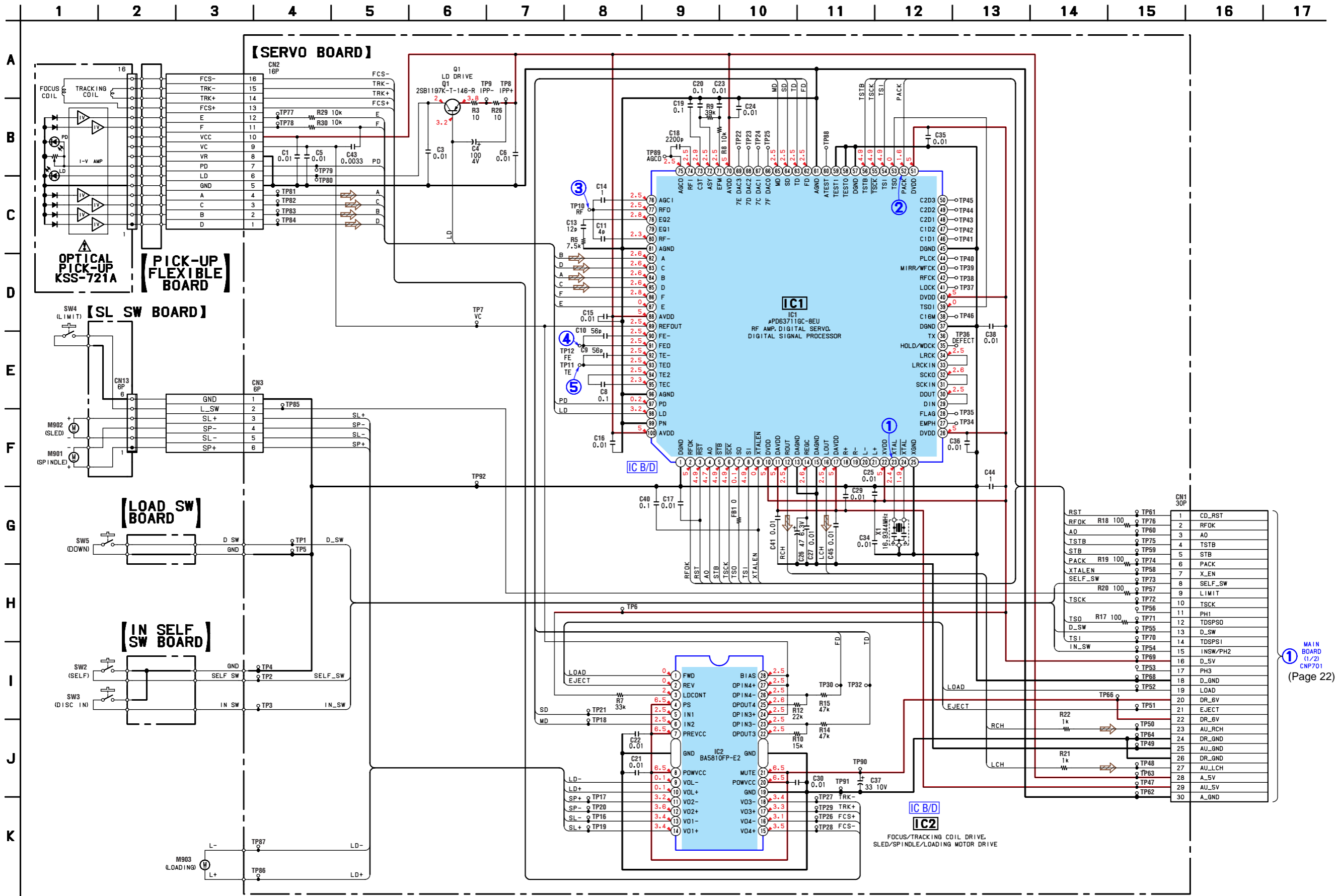

Note:
 • Voltage is dc with respect to ground under no-signal (detuned) condition.
 no mark : CD PLAY

1 MAIN BOARD (1/2) CNP701 (Page 22)

3-8. PRINTED WIRING BOARDS — MAIN SECTION — • Refer to page 14 for Circuit Boards Location.

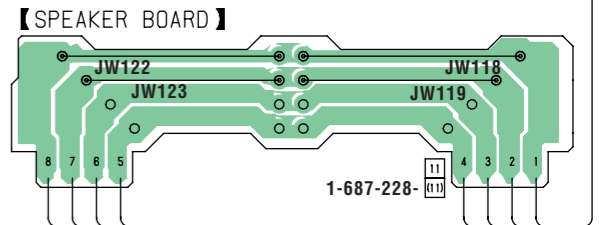
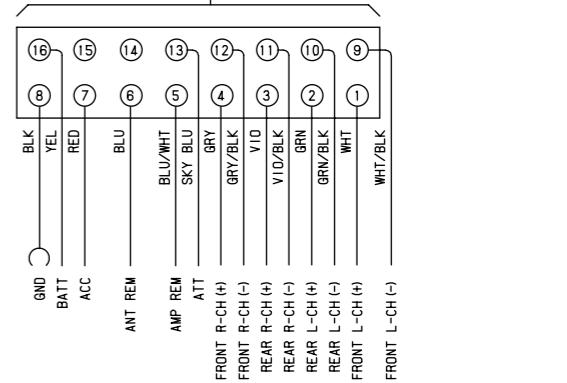
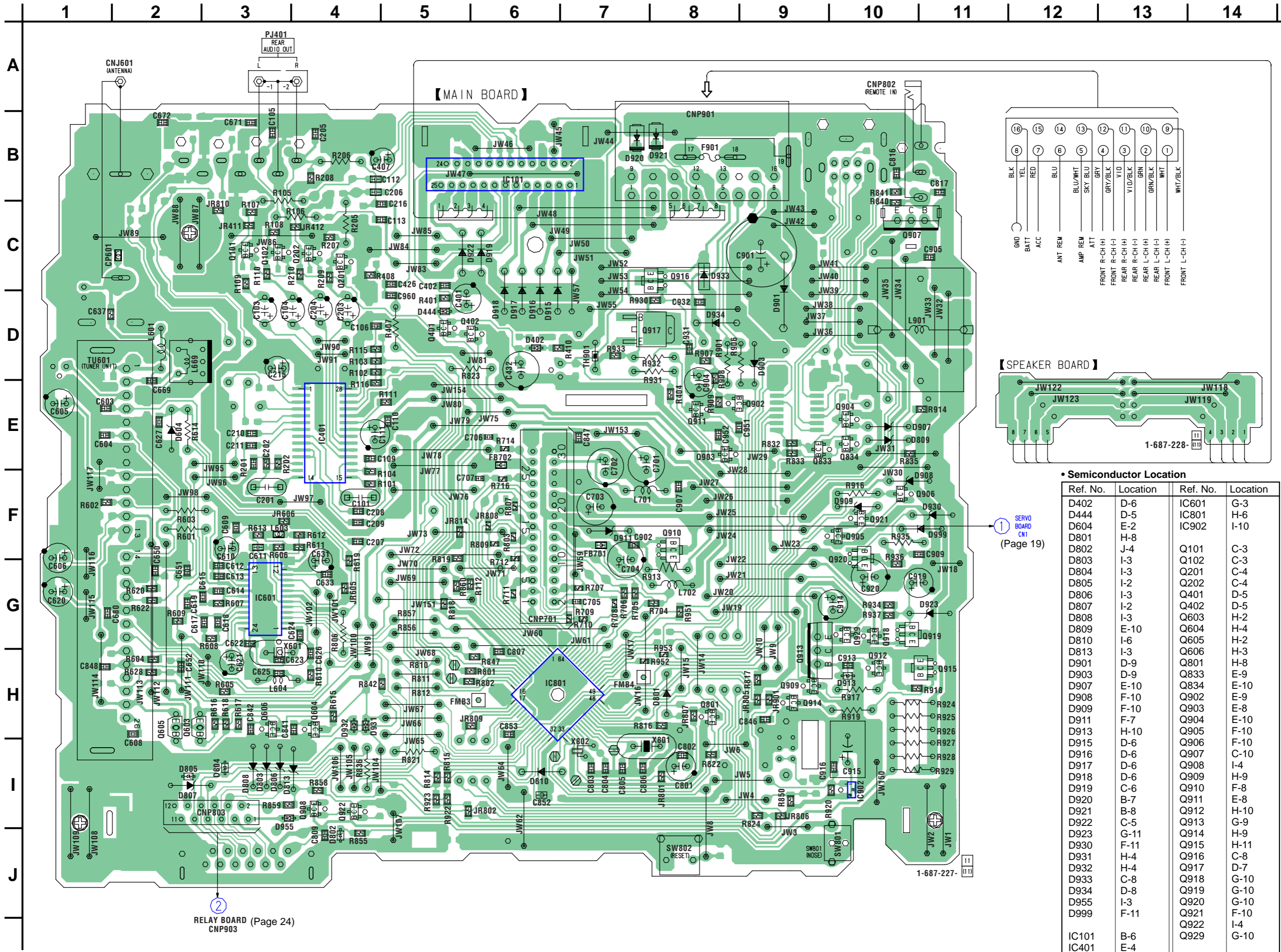

• Semiconductor Location

Ref. No.	Location	Ref. No.	Location
D402	D-6	IC601	G-3
D444	D-5	IC801	H-6
D604	E-2	IC902	I-10
D801	H-8		
D802	J-4	Q101	C-3
D803	I-3	Q102	C-3
D804	I-3	Q201	C-4
D805	I-2	Q202	C-4
D806	I-3	Q401	D-5
D807	I-2	Q402	D-5
D808	I-3	Q603	H-2
D809	E-10	Q604	H-4
D810	I-6	Q605	H-2
D813	I-3	Q606	H-3
D901	D-9	Q801	H-8
D903	D-9	Q833	E-9
D907	E-10	Q834	E-10
D908	F-10	Q902	E-9
D909	F-10	Q903	E-8
D911	F-7	Q904	E-10
D913	H-10	Q905	F-10
D915	D-6	Q906	F-10
D916	D-6	Q907	C-10
D917	D-6	Q908	I-4
D918	D-6	Q909	H-9
D919	C-6	Q910	F-8
D920	B-7	Q911	E-8
D921	B-8	Q912	H-10
D922	C-5	Q913	G-9
D923	G-11	Q914	H-9
D930	F-11	Q915	H-11
D931	H-4	Q916	C-8
D932	H-4	Q917	D-7
D933	C-8	Q918	G-10
D934	D-8	Q919	G-10
D955	I-3	Q920	G-10
D999	F-11	Q921	F-10
		Q922	I-4
		Q929	G-10

② RELAY BOARD (Page 24)
CNP903

① SERVO BOARD
CN1
(Page 19)

3-9. SCHEMATIC DIAGRAM — MAIN SECTION (1/2) — • Refer to page 17 for Waveforms.

1 2 3 4 5 6 7 8 9 10 11 12 13 14 15 16 17

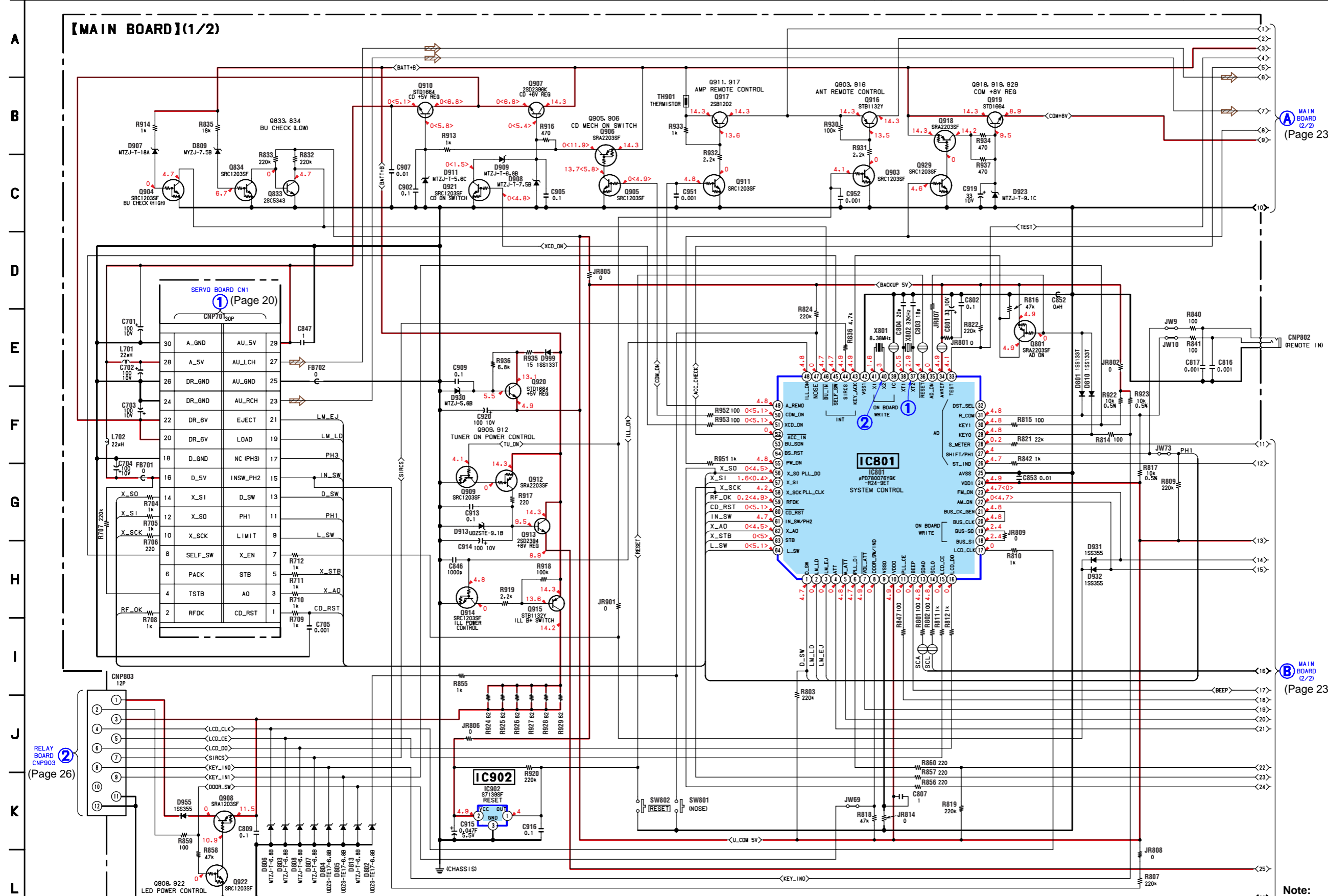

MAIN BOARD (2/2) (Page 23)

MAIN BOARD (2/2) (Page 23)

Note:
 • Voltage is dc with respect to ground under no-signal (detuned) condition.
 no mark : FM
 () : AM
 < > : CD PLAY

3-10. SCHEMATIC DIAGRAM — MAIN SECTION (2/2) — • Refer to page 17 for Waveform. • Refer to page 28 for IC Block Diagrams.

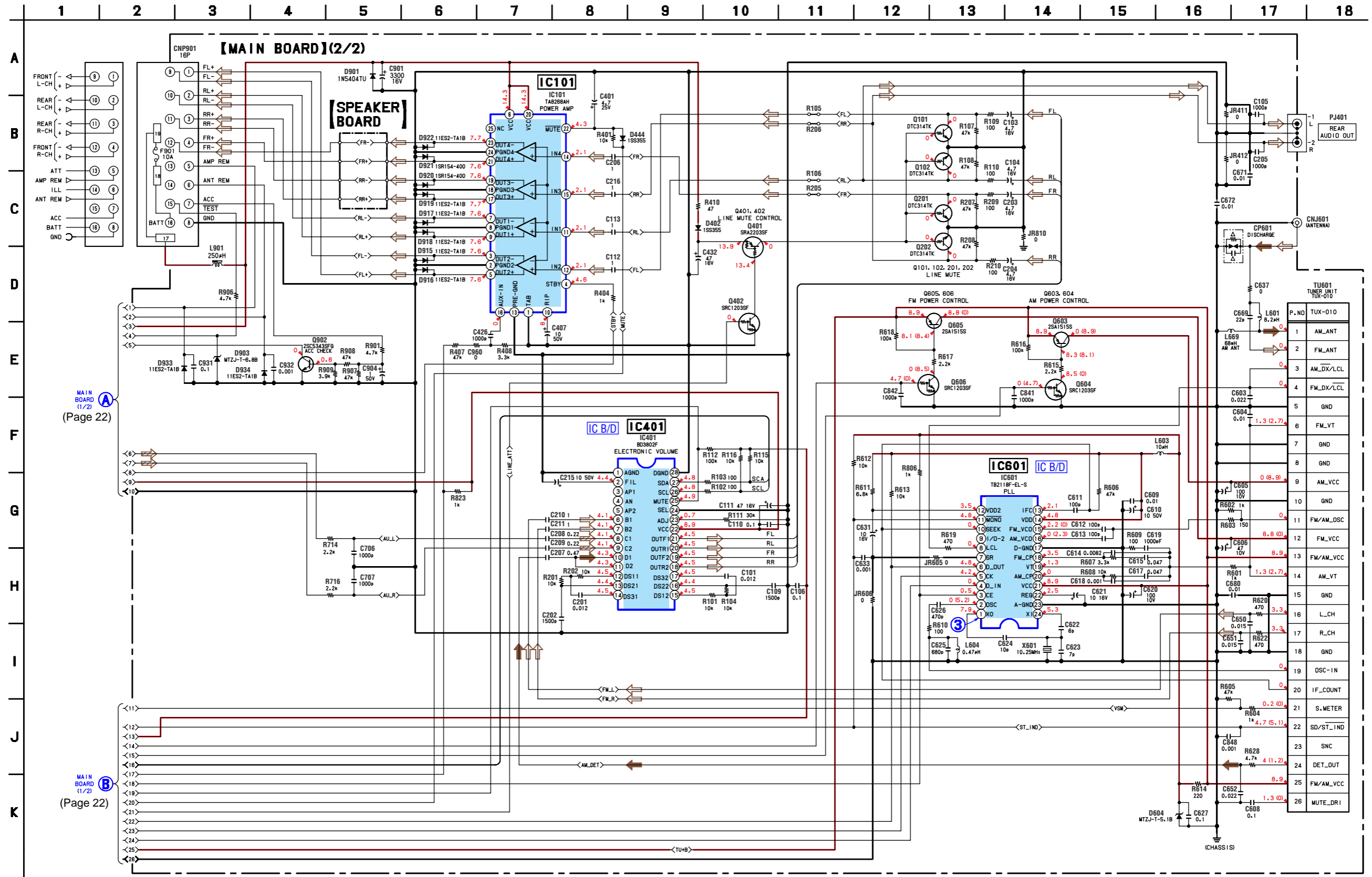

Note:
 • Voltage is dc with respect to ground under no-signal (detuned) condition.
 () : AM
 < > : CD PLAY

3-11. PRINTED WIRING BOARD — RELAY SECTION — • Refer to page 14 for Circuit Boards Location.

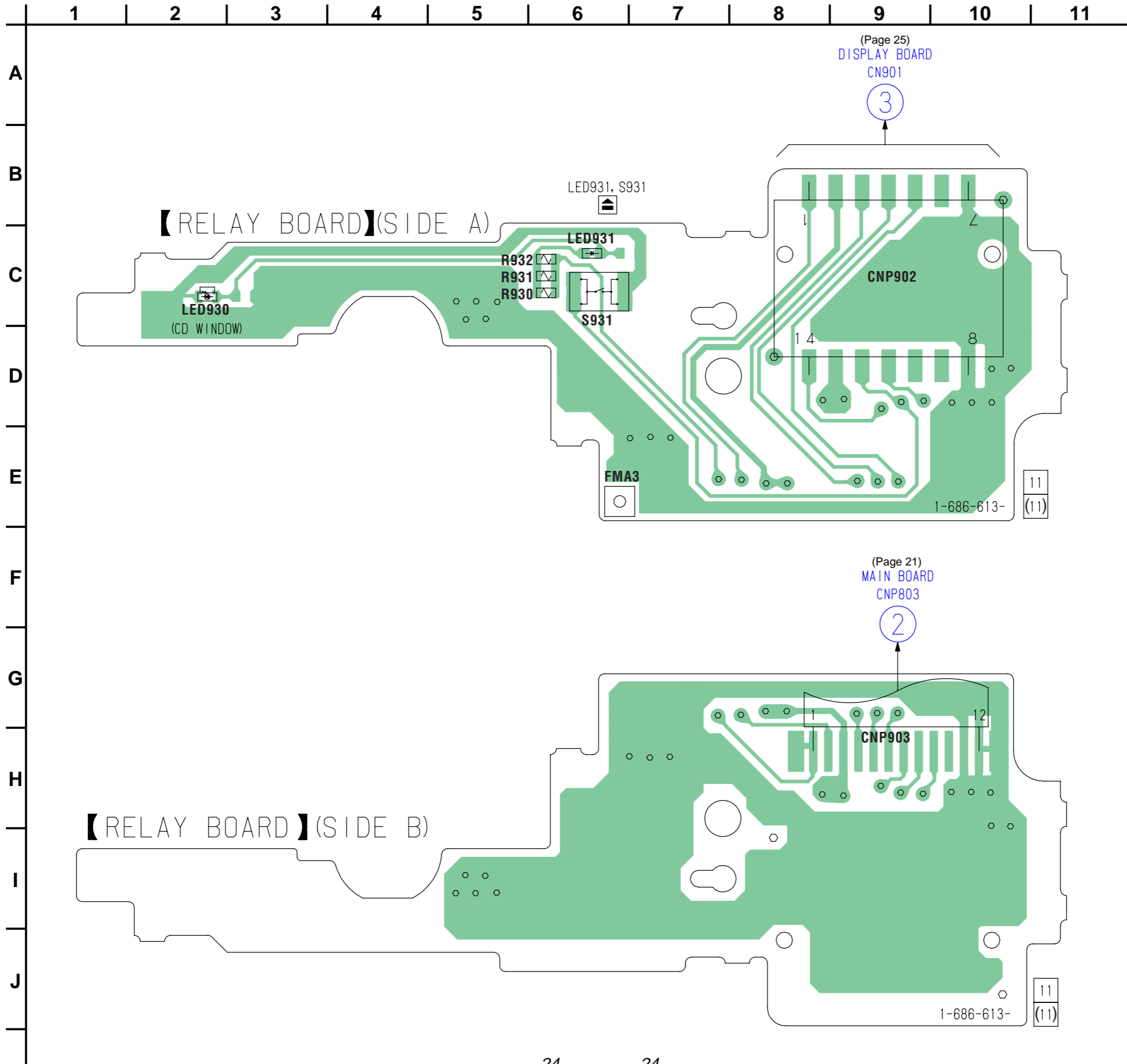

3-12. PRINTED WIRING BOARD — DISPLAY SECTION — • Refer to page 14 for Circuit Boards Location.

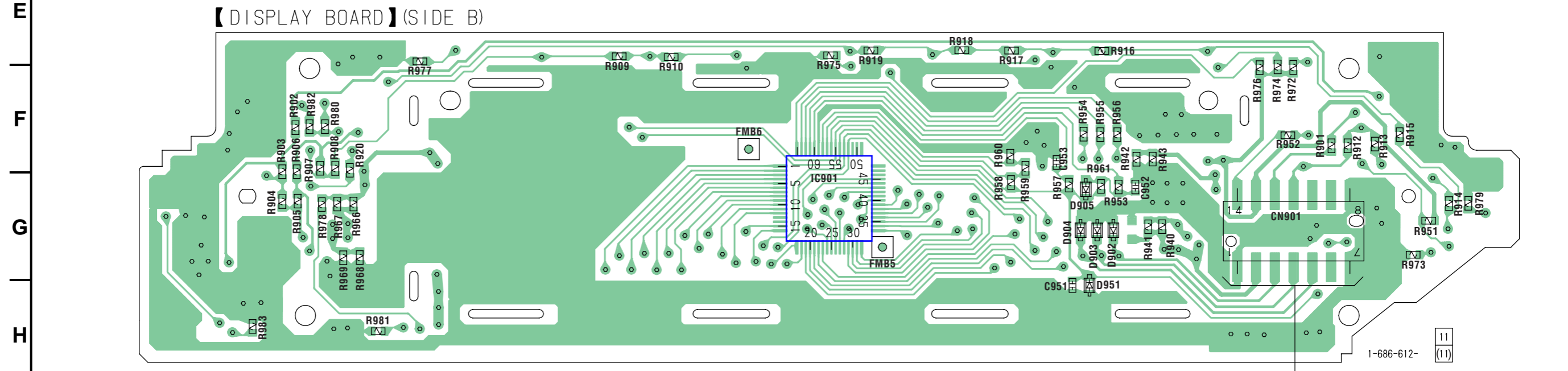
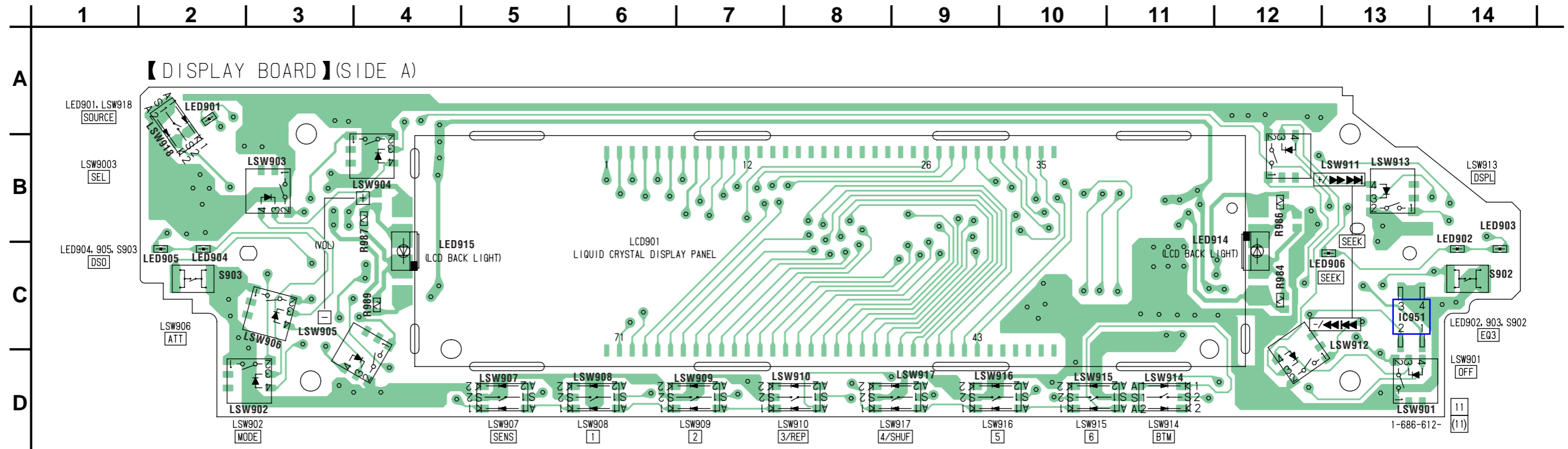

• Semiconductor Location

Ref. No.	Location	Ref. No.	Location
D902	G-11	LED901	A-2
D903	G-10	LED902	C-14
D904	G-10	LED903	C-14
D905	G-10	LED904	C-2
D951	H-10	LED905	C-2
IC901	G-8	LED906	C-13
IC951	C-13	LED914	C-12
		LED915	C-4

3
RELAY BOARD
CNP902
(Page 24)

3-13. SCHEMATIC DIAGRAM — DISPLAY, RELAY SECTION —

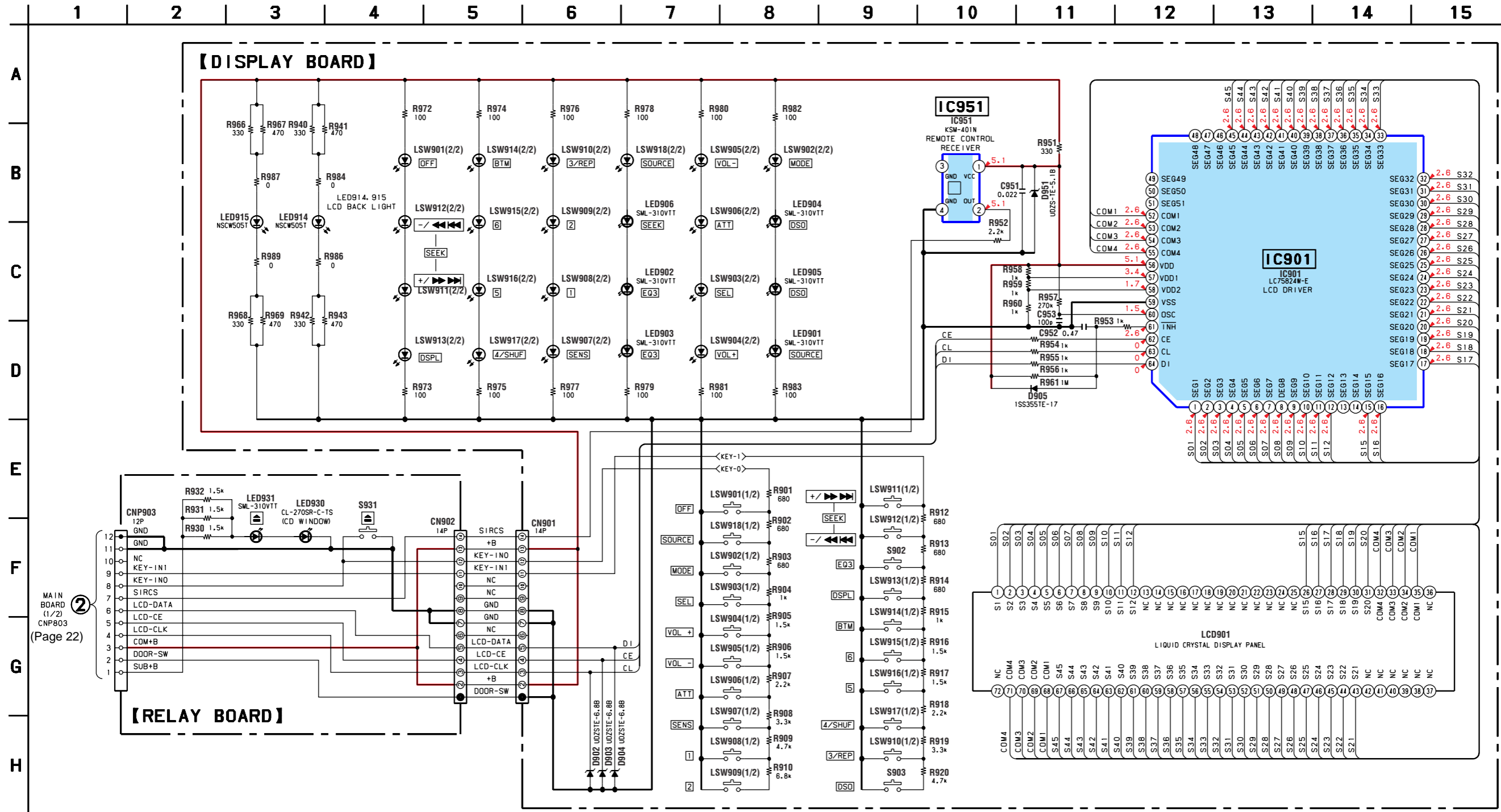

Note:
 • Voltage is dc with respect to ground under no-signal (detuned) condition.
 no mark : FM

3-14. IC BLOCK DIAGRAMS

IC1 μ PD63711GC-8EU (SERVO Board)

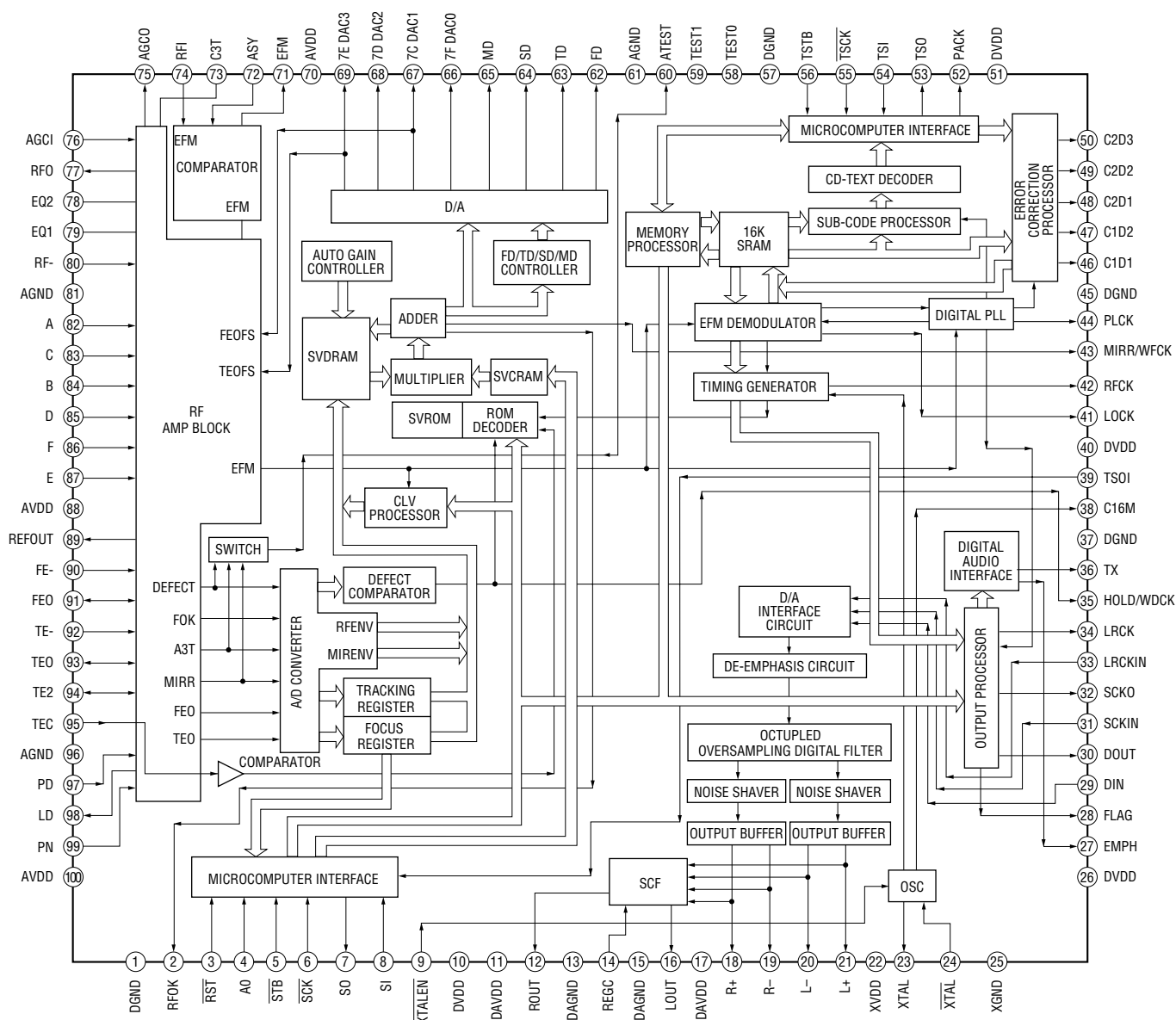

IC2 BA5810FP-E2 (SERVO Board)

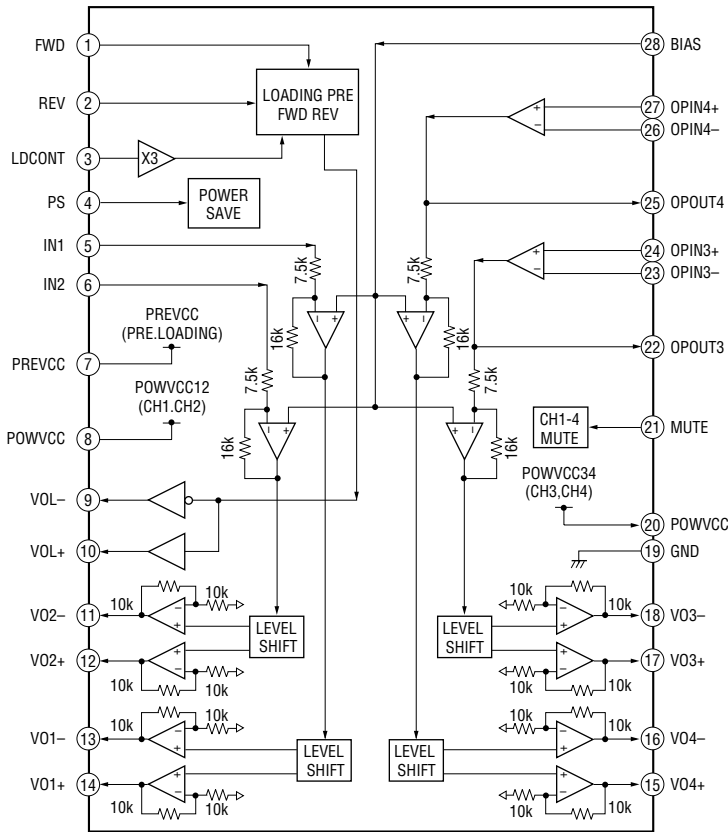

IC601 TB2118F-EL-S (MAIN Board)

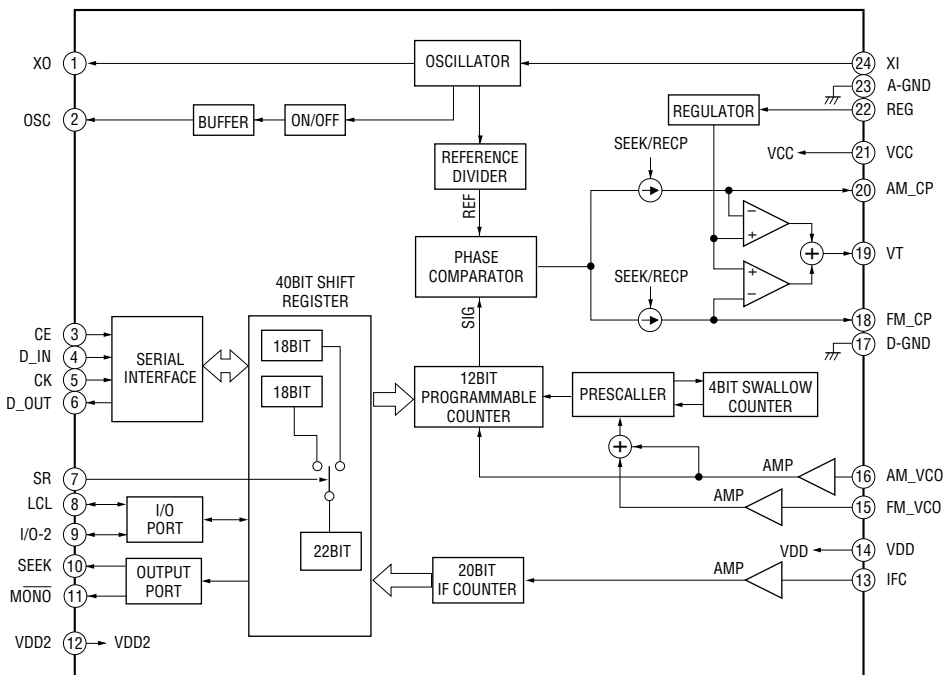

IC401 BD3802F (MAIN Board)

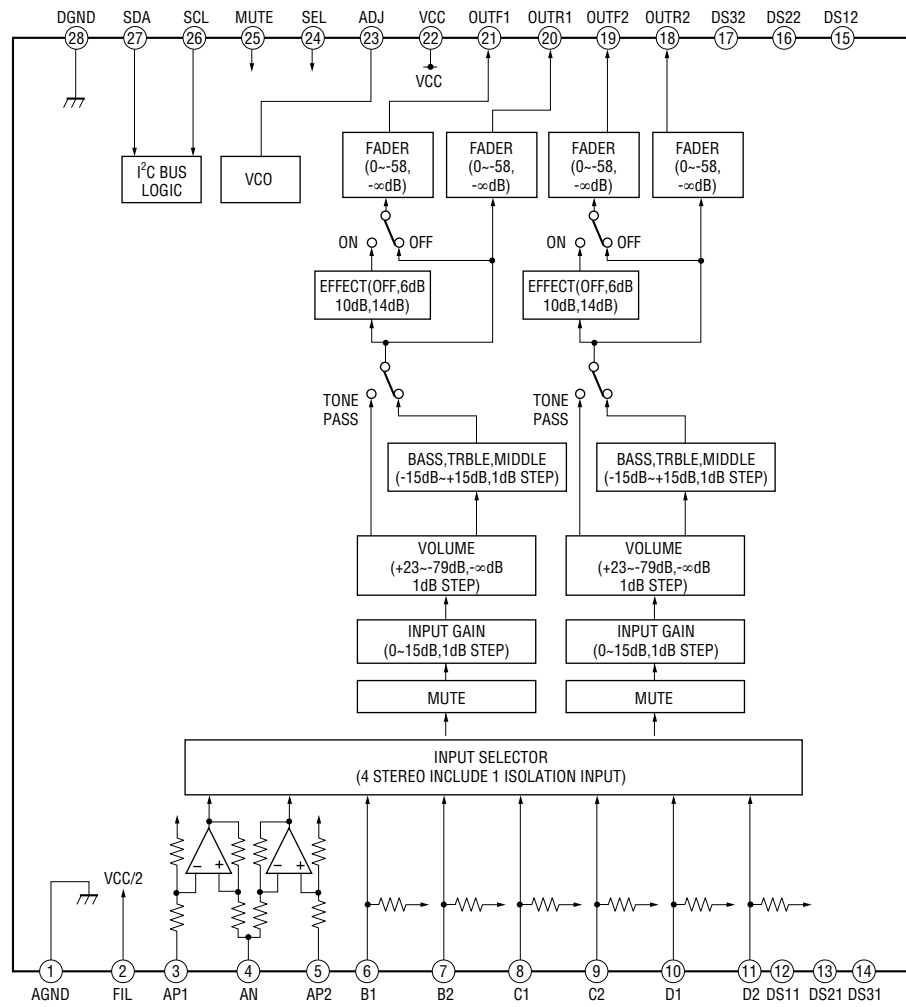

**SECTION 4
EXPLODED VIEWS**

NOTE:

- The mechanical parts with no reference number in the exploded views are not supplied.
- Items marked “*” are not stocked since they are seldom required for routine service. Some delay should be anticipated when ordering these items.
- -XX and -X mean standardized parts, so they may have some difference from the original one.

- Color Indication of Appearance Parts
Example :
KNOB, BALANCE (WHITE) ... (RED)
Parts Color Cabinet's Color
- Accessories are given in the last of this parts list.

The components identified by mark \triangle or dotted line with mark \triangle are critical for safety. Replace only with part number specified.

Les composants identifiés par une marque \triangle sont critiques pour la sécurité. Ne les remplacer que par une pièce portant le numéro spécifié.

4-1. CHASSIS SECTION

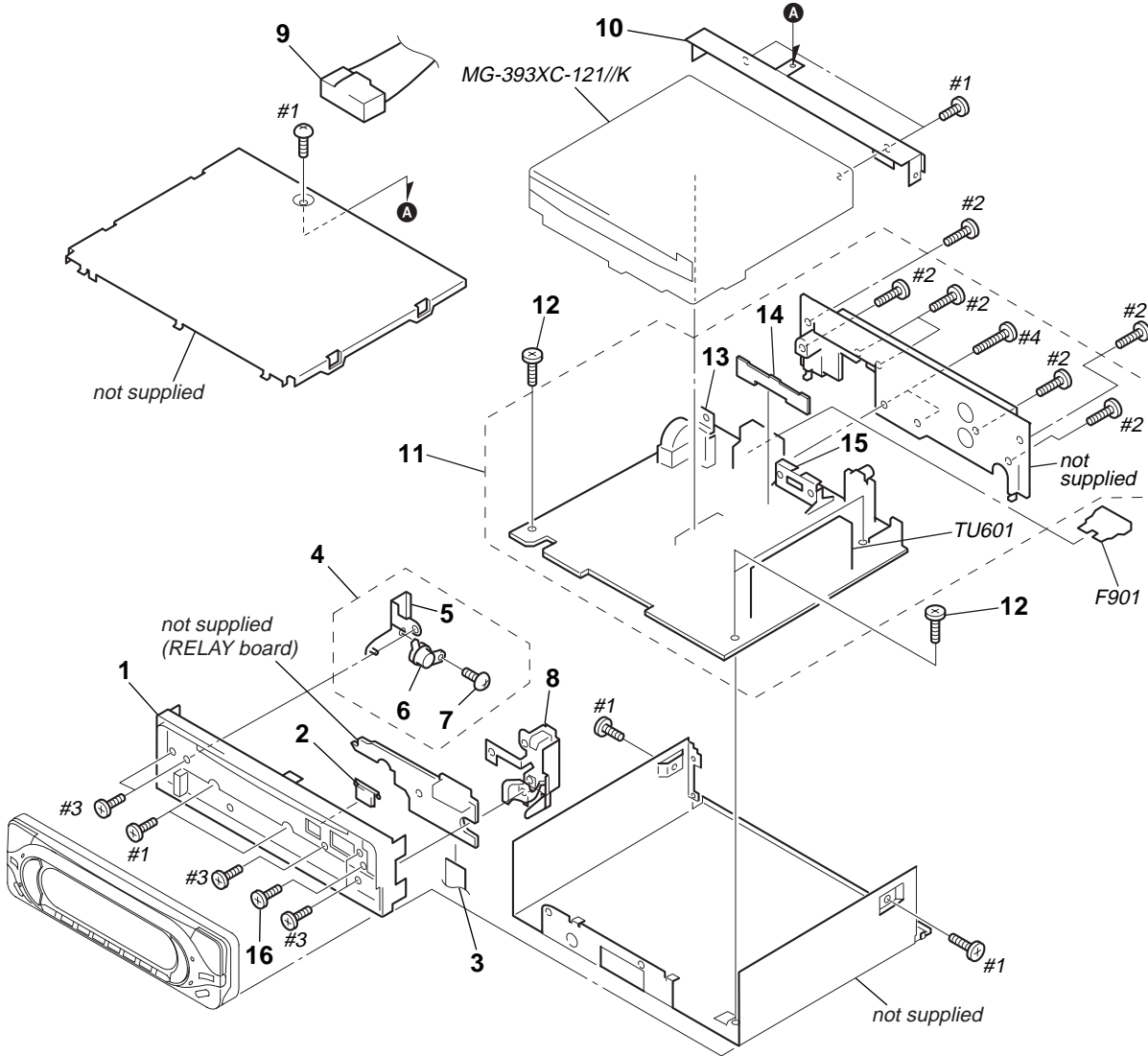

Ref. No.	Part No.	Description	Remark	Ref. No.	Part No.	Description	Remark
1	X-3382-626-1	PANEL ASSY (CD), SUB		12	3-922-535-11	SCREW (+BTT)	
2	3-246-030-01	BUTTON (EJECT)		13	3-041-261-11	BRACKET (TR)	
3	1-792-173-11	CABLE, FLAT (FFC) 12P		14	A-3274-646-A	SPEAKER BOARD, COMPLETE	
4	X-3376-686-4	GEAR ASSY		* 15	3-019-565-01	BRACKET (IC)	
* 5	X-3376-689-2	BRACKET (GEAR) ASSY		16	3-035-250-02	SCREW (LOCK)	
6	3-030-909-03	DAMPER, OIL		F901	1-532-877-11	FUSE (BLADE TYPE) (AUTO FUSE) 10A	
7	3-713-786-51	SCREW +P 2X3		TU601	A-3220-835-A	TUNER UNIT (TUX-010)	
8	X-3376-687-2	LOCK ASSY		#1	7-685-792-09	SCREW +PTT 2.6X6 (S)	
9	1-776-206-21	CORD (WITH CONNECTOR) (POWER)		#2	7-685-793-09	SCREW +PTT 2.6X8 (S)	
10	3-246-007-01	BRACKET (CD)		#3	7-621-772-20	SCREW +B 2X5	
11	A-3274-619-A	MAIN BOARD, COMPLETE		#4	7-685-795-09	SCREW +PTT 2.6X12 (S)	

4-2. FRONT PANEL SECTION

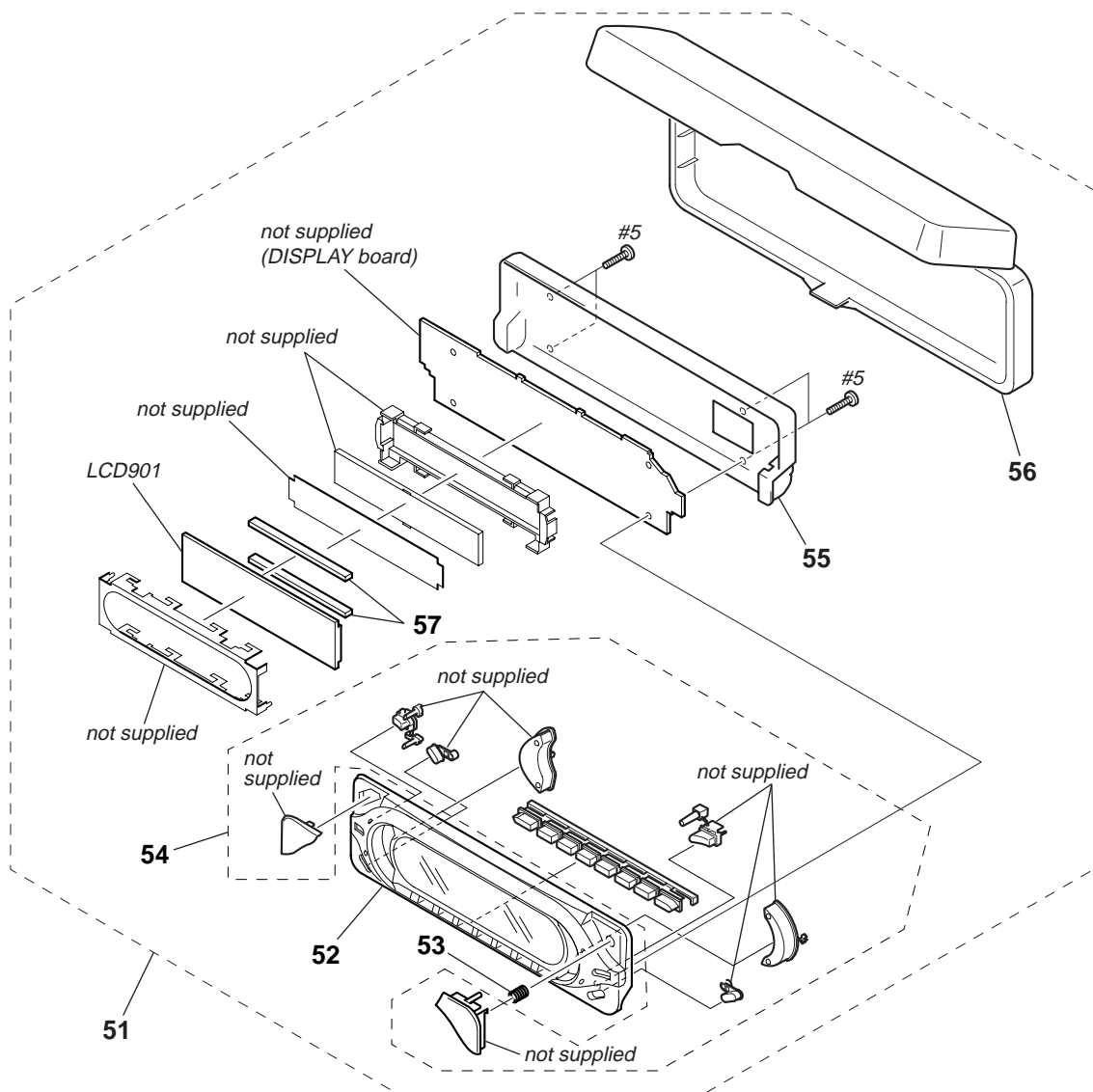

Ref. No.	Part No.	Description	Remark	Ref. No.	Part No.	Description	Remark
51	A-3315-962-A	PANEL COMPLETE ASSY, FRONT		56	X-3378-390-3	CASE ASSY (for FRONT PANEL)	
52	X-3382-760-1	PANEL (S) ASSY, FRONT		57	1-694-989-11	CONDUCTIVE BOARD, CONNECTION	
53	3-246-534-01	SPRING (RELEASE)		LCD901	1-805-077-11	DISPLAY PANEL, LIQUID CRYSTAL	
54	X-3382-921-1	BUTTON ASSY (S)		#5	7-685-106-19	SCREW +P 2X10 TYPE2 NON-SLIT	
55	X-3382-625-1	PANEL ASSY, FRONT BACK					

4-3. CD MECHANISM SECTION (1)
(MG-393XC-121//K)

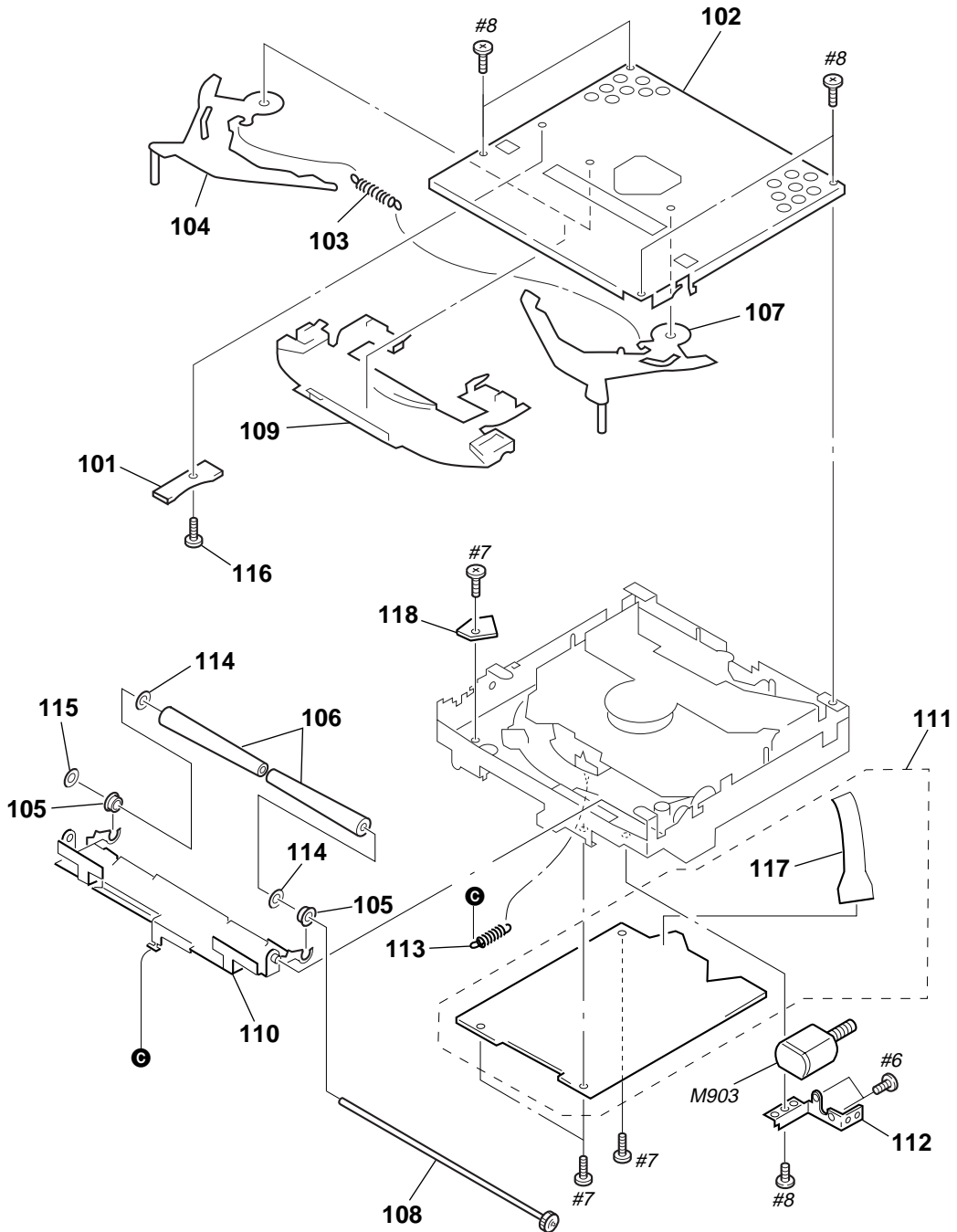

Ref. No.	Part No.	Description	Remark	Ref. No.	Part No.	Description	Remark
101	1-683-283-11	IN SELF SW BOARD		112	3-221-779-02	BRACKET (MOTOR)	
102	3-040-039-03	CHASSIS (T)		113	3-040-034-01	SPRING (RA), TENSION	
103	3-040-038-01	SPRING (LR), TENSION		114	3-040-042-01	WASHER	
104	3-040-050-01	LEVER (L)		115	3-043-880-01	RING (RA), RETAINING	
105	3-040-022-01	RETAINER (ROLLER), SHAFT		116	3-044-206-11	SCREW, SPECIAL	
106	3-040-044-01	ROLLER (S)		117	1-683-284-11	FLEXIBLE BOARD	
107	3-040-067-01	LEVER (R)		118	1-685-337-11	LOAD SW BOARD	
108	A-3301-980-A	SHAFT ROLLER ASSY		M903	A-3315-039-A	MOTOR SUB ASSY, LO (LOADING)	
109	3-040-037-01	GUIDE (DISC)		#6	7-627-553-17	SCREW, PRECISION +P 2X2 TYPE3	
110	3-040-040-03	ARM (ROLLER)		#7	7-628-253-00	SCREW, SPECIAL	
111	A-3283-233-A	SERVO BOARD, COMPLETE		#8	7-627-553-37	SCREW, PRECISION +P 2X3 TYPE3	

4-4. CD MECHANISM SECTION (2)
(MG-393XC-121//K)

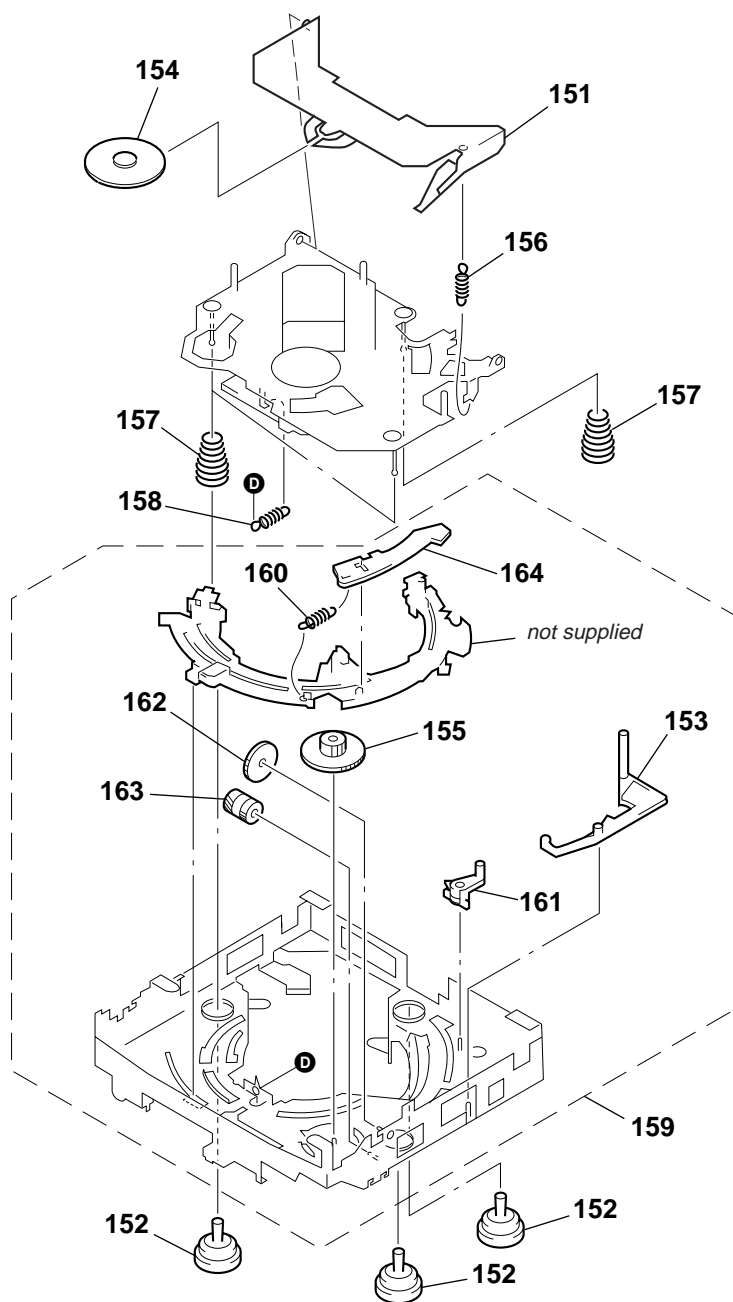

Ref. No.	Part No.	Description	Remark	Ref. No.	Part No.	Description	Remark
151	3-040-025-02	ARM, CHUCKING		158	3-040-033-01	SPRING (KF1), TENSION	
152	3-040-031-01	DAMPER (T)		159	A-3307-422-A	CHASSIS (M) COMPLETE ASSY	
153	3-040-056-01	LEVER (D)		160	3-040-059-01	SPRING (TR), TENSION	
154	3-040-024-01	RETAINER (DISC)		161	3-040-057-01	LEVER (LOCK)	
155	3-040-054-01	WHEEL (LW), WORM		162	3-040-058-01	GEAR (MDL)	
156	3-040-026-01	SPRING (CH), TENSION		163	3-040-052-01	WHEEL (U), WORM	
157	3-040-032-01	SPRING (FL), COMPRESSION		164	3-040-051-02	LEVER (TR)	

4-5. CD MECHANISM SECTION (3)
(MG-393XC-121//K)

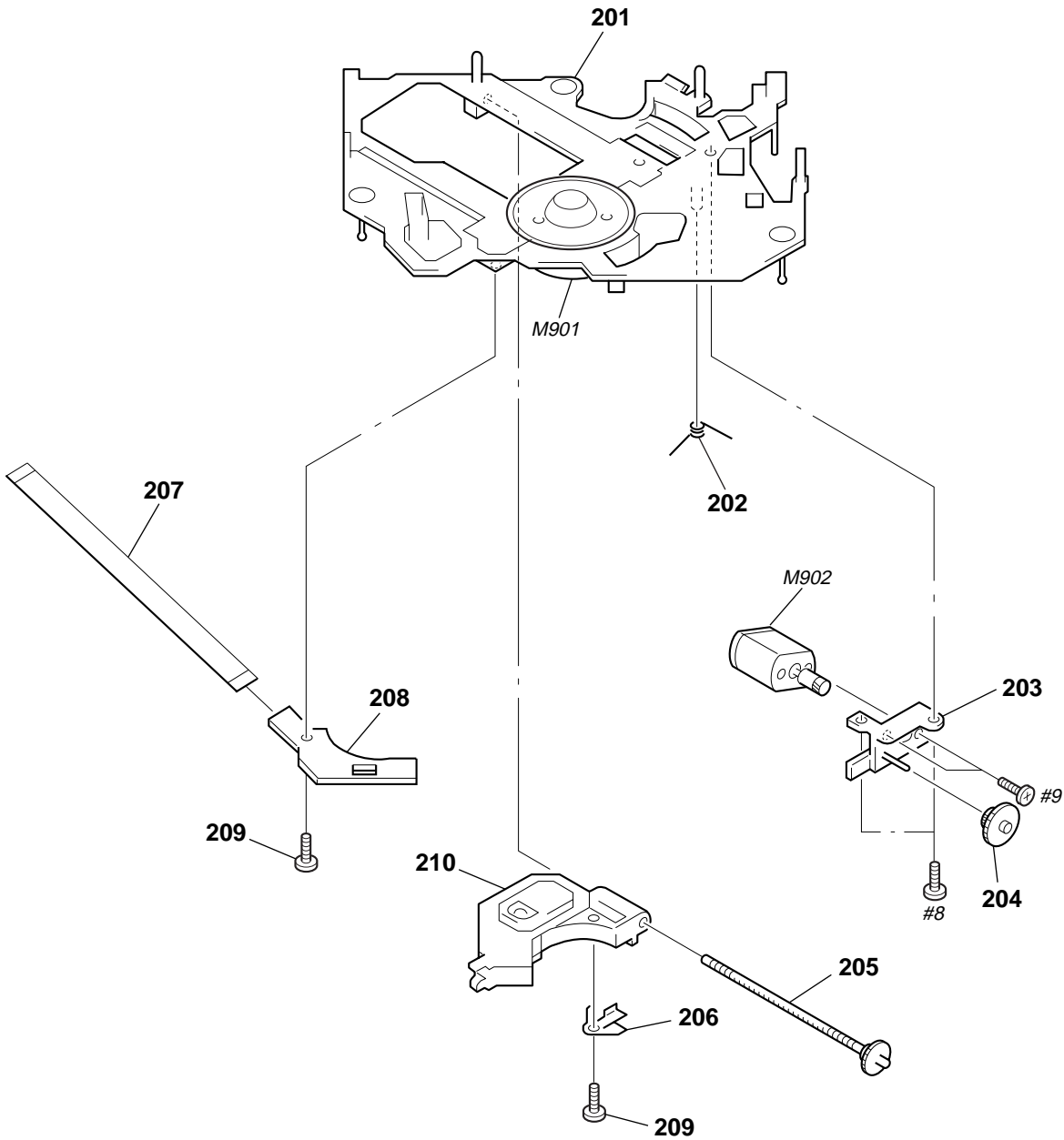

<p>The components identified by mark \triangle or dotted line with mark \triangle are critical for safety. Replace only with part number specified.</p>	<p>Les composants identifiés par une marque \triangle sont critiques pour la sécurité. Ne les remplacer que par une pièce portant le numéro spécifié.</p>
---	--

Ref. No.	Part No.	Description	Remark	Ref. No.	Part No.	Description	Remark
201	X-3378-480-1	CHASSIS (OP) ASSY (including M901)		208	1-683-282-11	SL SW BOARD	
202	3-040-029-01	SPRING (SL), TORSION		209	3-909-607-01	SCREW	
203	3-040-045-01	BASE (DRIVING)		\triangle 210	8-820-165-06	OPTICAL PICK-UP KSS-721A/C-RP	
204	3-040-194-01	GEAR (MIDWAY)		M902	A-3301-985-A	MOTOR ASSY, SLED (SLED)	
205	A-3301-983-A	SHAFT (FEED) ASSY		#8	7-627-553-37	SCREW, PRECISION +P 2X3 TYPE3	
206	3-040-030-01	SPRING (FEED), PLATE		#9	7-627-850-28	SCREW, PRECISION +P 1.4X3	
207	1-823-641-11	CABLE, FLEXIBLE FLAT (6 CORE)					

SECTION 5 ELECTRICAL PARTS LIST

DISPLAY

NOTE:

- Due to standardization, replacements in the parts list may be different from the parts specified in the diagrams or the components used on the set.
- -XX and -X mean standardized parts, so they may have some difference from the original one.
- RESISTORS
All resistors are in ohms.
METAL: Metal-film resistor.
METAL OXIDE: Metal oxide-film resistor.
F: nonflammable

- Items marked “*” are not stocked since they are seldom required for routine service. Some delay should be anticipated when ordering these items.
- SEMICONDUCTORS
In each case, u : μ, for example:
uA.. : μA.. uPA.. : μPA..
uPB.. : μPB.. uPC.. : μPC.. uPD.. : μPD..
- CAPACITORS
uF : μF
- COILS
uH : μH

The components identified by mark \triangle or dotted line with mark \triangle are critical for safety. Replace only with part number specified.

Les composants identifiés par une marque \triangle sont critiques pour la sécurité. Ne les remplacer que par une pièce portant le numéro spécifié.

When indicating parts by reference number, please include the board.

Ref. No.	Part No.	Description	Remark	Ref. No.	Part No.	Description	Remark
		DISPLAY BOARD *****		LSW907	1-771-883-11	SWITCH, TACTILE (WITH LED) (SENS)	
				LSW908	1-771-883-11	SWITCH, TACTILE (WITH LED) (1)	
				LSW909	1-771-883-11	SWITCH, TACTILE (WITH LED) (2)	
				LSW910	1-771-883-11	SWITCH, TACTILE (WITH LED) (3/REP)	
				LSW911	1-771-476-11	SWITCH, KEYBOARD (WITH LED)	(SEEK + $\blacktriangleright\blacktriangleright\blacktriangleright$)
		< CAPACITOR >		LSW912	1-771-476-11	SWITCH, KEYBOARD (WITH LED)	(SEEK - $\blacktriangleleft\blacktriangleleft\blacktriangleleft$)
C951	1-164-227-11	CERAMIC CHIP 0.022uF 10%	25V	LSW913	1-771-476-11	SWITCH, KEYBOARD (WITH LED) (DSPL)	
C952	1-125-891-11	CERAMIC CHIP 0.47uF 10%	10V	LSW914	1-771-883-11	SWITCH, TACTILE (WITH LED) (BTM)	
C953	1-162-927-11	CERAMIC CHIP 100PF 5%	50V	LSW915	1-771-883-11	SWITCH, TACTILE (WITH LED) (6)	
		< CONNECTOR >		LSW916	1-771-883-11	SWITCH, TACTILE (WITH LED) (5)	
CN901	1-817-158-11	PLUG, CONNECTOR 14P		LSW917	1-771-883-11	SWITCH, TACTILE (WITH LED) (4/SHUF)	
		< DIODE >		LSW918	1-771-883-11	SWITCH, TACTILE (WITH LED) (SOURCE)	
D902	8-719-978-33	DIODE DTZ-TT11-6.8B				< RESISTOR >	
D903	8-719-978-33	DIODE DTZ-TT11-6.8B		R901	1-216-819-11	METAL CHIP 680 5%	1/10W
D904	8-719-978-33	DIODE DTZ-TT11-6.8B		R902	1-216-819-11	METAL CHIP 680 5%	1/10W
D905	8-719-988-61	DIODE 1SS355TE-17		R903	1-216-819-11	METAL CHIP 680 5%	1/10W
D951	8-719-069-54	DIODE UDZS-TE-17-5.1B		R904	1-216-821-11	METAL CHIP 1K 5%	1/10W
		< IC >		R905	1-216-823-11	METAL CHIP 1.5K 5%	1/10W
IC901	6-702-852-01	IC LC75824W-E		R906	1-216-823-11	METAL CHIP 1.5K 5%	1/10W
IC951	8-749-017-35	IC KSM-401N		R907	1-216-825-11	METAL CHIP 2.2K 5%	1/10W
		< LIQUID CRYSTAL DISPLAY >		R908	1-216-827-11	METAL CHIP 3.3K 5%	1/10W
LCD901	1-805-077-11	DISPLAY PANEL, LIQUID CRYSTAL		R909	1-216-829-11	METAL CHIP 4.7K 5%	1/10W
		< DIODE >		R910	1-218-867-11	METAL CHIP 6.8K 5%	1/10W
LED901	8-719-053-09	LED SML-310VTT86 (SOURCE)		R912	1-216-819-11	METAL CHIP 680 5%	1/10W
LED902	8-719-053-09	LED SML-310VTT86 (EQ3)		R913	1-216-819-11	METAL CHIP 680 5%	1/10W
LED903	8-719-053-09	LED SML-310VTT86 (EQ3)		R914	1-216-819-11	METAL CHIP 680 5%	1/10W
LED904	8-719-053-09	LED SML-310VTT86 (DSO)		R915	1-216-821-11	METAL CHIP 1K 5%	1/10W
LED905	8-719-053-09	LED SML-310VTT86 (DSO)		R916	1-216-823-11	METAL CHIP 1.5K 5%	1/10W
LED906	8-719-053-09	LED SML-310VTT86 (SEEK)		R917	1-216-823-11	METAL CHIP 1.5K 5%	1/10W
LED914	6-500-459-01	LED NSCW505T-ARS (LCD BACK LIGHT)		R918	1-216-825-11	METAL CHIP 2.2K 5%	1/10W
LED915	6-500-459-01	LED NSCW505T-ARS (LCD BACK LIGHT)		R919	1-216-827-11	METAL CHIP 3.3K 5%	1/10W
		< SWITCH >		R920	1-216-829-11	METAL CHIP 4.7K 5%	1/10W
LSW901	1-771-476-11	SWITCH, KEYBOARD (WITH LED) (OFF)		R940	1-216-815-11	METAL CHIP 330 5%	1/10W
LSW902	1-771-476-11	SWITCH, KEYBOARD (WITH LED) (MODE)		R941	1-216-817-11	METAL CHIP 470 5%	1/10W
LSW903	1-771-476-11	SWITCH, KEYBOARD (WITH LED) (SEL)		R942	1-216-815-11	METAL CHIP 330 5%	1/10W
LSW904	1-771-476-11	SWITCH, KEYBOARD (WITH LED) (VOL +)		R943	1-216-817-11	METAL CHIP 470 5%	1/10W
LSW905	1-771-476-11	SWITCH, KEYBOARD (WITH LED) (VOL -)		R951	1-216-815-11	METAL CHIP 330 5%	1/10W
				R952	1-216-825-11	METAL CHIP 2.2K 5%	1/10W
LSW906	1-771-476-11	SWITCH, KEYBOARD (WITH LED) (ATT)		R953	1-216-821-11	METAL CHIP 1K 5%	1/10W
				R954	1-216-821-11	METAL CHIP 1K 5%	1/10W
				R955	1-216-821-11	METAL CHIP 1K 5%	1/10W
				R956	1-216-821-11	METAL CHIP 1K 5%	1/10W

CDX-L510X

DISPLAY	IN SELF SW	LOAD SW	MAIN
----------------	-------------------	----------------	-------------

Ref. No.	Part No.	Description	Remark
R957	1-216-850-11	METAL CHIP 270K	5% 1/10W
R958	1-216-821-11	METAL CHIP 1K	5% 1/10W
R959	1-216-821-11	METAL CHIP 1K	5% 1/10W
R960	1-216-821-11	METAL CHIP 1K	5% 1/10W
R961	1-216-857-11	METAL CHIP 1M	5% 1/10W
R966	1-216-815-11	METAL CHIP 330	5% 1/10W
R967	1-216-817-11	METAL CHIP 470	5% 1/10W
R968	1-216-815-11	METAL CHIP 330	5% 1/10W
R969	1-216-817-11	METAL CHIP 470	5% 1/10W
R972	1-216-809-11	METAL CHIP 100	5% 1/10W
R973	1-216-809-11	METAL CHIP 100	5% 1/10W
R974	1-216-809-11	METAL CHIP 100	5% 1/10W
R975	1-216-809-11	METAL CHIP 100	5% 1/10W
R976	1-216-809-11	METAL CHIP 100	5% 1/10W
R977	1-216-809-11	METAL CHIP 100	5% 1/10W
R978	1-216-809-11	METAL CHIP 100	5% 1/10W
R979	1-216-809-11	METAL CHIP 100	5% 1/10W
R980	1-216-809-11	METAL CHIP 100	5% 1/10W
R981	1-216-809-11	METAL CHIP 100	5% 1/10W
R982	1-216-809-11	METAL CHIP 100	5% 1/10W
R983	1-216-809-11	METAL CHIP 100	5% 1/10W
R984	1-216-864-11	METAL CHIP 0	5% 1/10W
R986	1-216-864-11	METAL CHIP 0	5% 1/10W
R987	1-216-864-11	METAL CHIP 0	5% 1/10W
R989	1-216-864-11	METAL CHIP 0	5% 1/10W
< SWITCH >			
S902	1-771-884-11	SWITCH, TACTILE (WITH LED) (EQ3)	
S903	1-771-884-11	SWITCH, TACTILE (WITH LED) (DSO)	

1-683-283-11	IN SELF SW BOARD		*****
< SWITCH >			
SW2	1-529-566-31	SWITCH, PUSH (1 KEY) (SELF)	
SW3	1-529-566-31	SWITCH, PUSH (1 KEY) (DISC IN)	

1-685-337-11	LOAD SW BOARD		*****
< SWITCH >			
SW5	1-529-566-31	SWITCH, PUSH (1 KEY) (DOWN)	

A-3274-619-A	MAIN BOARD, COMPLETE (including SPEAKER BOARD, COMPLETE)		*****
*	3-019-565-01	BRACKET (IC)	
	3-041-261-11	BRACKET (TR)	
	7-685-793-09	SCREW +PTT 2.6X8 (S)	
	7-685-795-09	SCREW +PTT 2.6X12 (S)	
< CAPACITOR >			
C101	1-136-154-00	FILM 0.012uF	5% 50V
C103	1-124-259-11	ELECT 4.7uF	20% 16V
C104	1-124-259-11	ELECT 4.7uF	20% 16V
C105	1-162-964-11	CERAMIC CHIP 0.001uF	10% 50V
C106	1-107-826-11	CERAMIC CHIP 0.1uF	10% 16V

Ref. No.	Part No.	Description	Remark
C109	1-162-965-11	CERAMIC CHIP 0.0015uF	10% 50V
C110	1-164-360-11	CERAMIC CHIP 0.1uF	16V
C111	1-124-589-11	ELECT 47uF	20% 16V
C112	1-164-346-11	CERAMIC CHIP 1uF	16V
C113	1-164-346-11	CERAMIC CHIP 1uF	16V
C201	1-136-154-00	FILM 0.012uF	5% 50V
C202	1-162-965-11	CERAMIC CHIP 0.0015uF	10% 50V
C203	1-124-259-11	ELECT 4.7uF	20% 16V
C204	1-124-259-11	ELECT 4.7uF	20% 16V
C205	1-162-964-11	CERAMIC CHIP 0.001uF	10% 50V
C206	1-164-346-11	CERAMIC CHIP 1uF	16V
C207	1-125-891-11	CERAMIC CHIP 0.47uF	10% 10V
C208	1-115-467-11	CERAMIC CHIP 0.22uF	10% 10V
C209	1-115-467-11	CERAMIC CHIP 0.22uF	10% 10V
C210	1-125-837-11	CERAMIC CHIP 1uF	10% 6.3V
C211	1-125-837-11	CERAMIC CHIP 1uF	10% 6.3V
C215	1-126-964-11	ELECT 10uF	20% 50V
C216	1-164-346-11	CERAMIC CHIP 1uF	16V
C401	1-126-163-11	ELECT 4.7uF	20% 50V
C407	1-126-964-11	ELECT 10uF	20% 50V
C426	1-162-964-11	CERAMIC CHIP 0.001uF	10% 50V
C432	1-124-589-11	ELECT 47uF	20% 16V
C603	1-164-227-11	CERAMIC CHIP 0.022uF	10% 25V
C604	1-162-970-11	CERAMIC CHIP 0.01uF	10% 25V
C605	1-104-665-11	ELECT 100uF	20% 10V
C606	1-126-947-11	ELECT 47uF	20% 10V
C608	1-164-156-11	CERAMIC CHIP 0.1uF	25V
C609	1-162-970-11	CERAMIC CHIP 0.01uF	10% 25V
C610	1-126-964-11	ELECT 10uF	20% 50V
C611	1-162-927-11	CERAMIC CHIP 100PF	5% 50V
C612	1-162-927-11	CERAMIC CHIP 100PF	5% 50V
C613	1-162-927-11	CERAMIC CHIP 100PF	5% 50V
C614	1-164-174-11	CERAMIC CHIP 0.0082uF	10% 25V
C615	1-165-176-11	CERAMIC CHIP 0.047uF	10% 16V
C617	1-165-176-11	CERAMIC CHIP 0.047uF	10% 16V
C618	1-162-964-11	CERAMIC CHIP 0.001uF	10% 50V
C619	1-162-964-11	CERAMIC CHIP 0.001uF	10% 50V
C620	1-104-665-11	ELECT 100uF	20% 10V
C621	1-104-396-11	ELECT 10uF	20% 16V
C622	1-162-911-11	CERAMIC CHIP 6PF	0.5PF 50V
C623	1-162-912-11	CERAMIC CHIP 7PF	0.5PF 50V
C624	1-162-915-11	CERAMIC CHIP 10PF	0.5PF 50V
C625	1-162-963-11	CERAMIC CHIP 680PF	10% 50V
C626	1-164-315-11	CERAMIC CHIP 470PF	5% 50V
C627	1-164-156-11	CERAMIC CHIP 0.1uF	25V
C631	1-126-964-11	ELECT 10uF	20% 50V
C633	1-162-964-11	CERAMIC CHIP 0.001uF	10% 50V
C637	1-216-295-11	SHORT CHIP 0	
C650	1-164-245-11	CERAMIC CHIP 0.015uF	10% 25V
C651	1-164-245-11	CERAMIC CHIP 0.015uF	10% 25V
C652	1-164-227-11	CERAMIC CHIP 0.022uF	10% 25V
C669	1-162-919-11	CERAMIC CHIP 22PF	5% 50V
C671	1-162-970-11	CERAMIC CHIP 0.01uF	10% 25V
C672	1-162-970-11	CERAMIC CHIP 0.01uF	10% 25V
C680	1-162-970-11	CERAMIC CHIP 0.01uF	10% 25V
C701	1-124-584-00	ELECT 100uF	20% 10V
C702	1-124-584-00	ELECT 100uF	20% 10V
C703	1-124-584-00	ELECT 100uF	20% 10V

Ref. No.	Part No.	Description	Remark	Ref. No.	Part No.	Description	Remark
C704	1-124-584-00	ELECT	100uF 20% 10V	D804	8-719-978-33	DIODE DTZ-TT11-6.8B	
C705	1-162-964-11	CERAMIC CHIP	0.001uF 10% 50V	D805	8-719-978-33	DIODE DTZ-TT11-6.8B	
C706	1-162-964-11	CERAMIC CHIP	0.001uF 10% 50V	D806	8-719-109-97	DIODE RD6.8ES-B2	
C707	1-162-964-11	CERAMIC CHIP	0.001uF 10% 50V	D807	8-719-109-97	DIODE RD6.8ES-B2	
C801	1-124-229-00	ELECT	33uF 20% 10V	D808	8-719-109-97	DIODE RD6.8ES-B2	
C802	1-164-156-11	CERAMIC CHIP	0.1uF 25V	D809	8-719-921-63	DIODE MTZJ-7.5B	
C803	1-162-918-11	CERAMIC CHIP	18PF 5% 50V	D810	8-719-991-33	DIODE 1SS133T-77	
C804	1-164-160-11	CERAMIC CHIP	20PF 5% 50V	D813	8-719-109-97	DIODE RD6.8ES-B2	
C807	1-115-156-11	CERAMIC CHIP	1uF 10V	D901	8-719-049-38	DIODE 1N5404TU	
C809	1-164-156-11	CERAMIC CHIP	0.1uF 25V	D903	8-719-109-97	DIODE RD6.8ES-B2	
C816	1-162-964-11	CERAMIC CHIP	0.001uF 10% 50V	D907	8-719-110-49	DIODE RD18ES-B2	
C817	1-162-964-11	CERAMIC CHIP	0.001uF 10% 50V	D908	8-719-921-63	DIODE MTZJ-7.5B	
C841	1-162-964-11	CERAMIC CHIP	0.001uF 10% 50V	D909	8-719-109-97	DIODE RD6.8ES-B2	
C842	1-162-964-11	CERAMIC CHIP	0.001uF 10% 50V	D911	8-719-109-89	DIODE RD5.6ES-B2	
C846	1-162-964-11	CERAMIC CHIP	0.001uF 10% 50V	D913	8-719-069-60	DIODE UDZS-TE-17-9.1B	
C847	1-115-156-11	CERAMIC CHIP	1uF 10V	D915	8-719-200-82	DIODE 11ES2	
C848	1-162-964-11	CERAMIC CHIP	0.001uF 10% 50V	D916	8-719-200-82	DIODE 11ES2	
C852	1-469-144-21	FERRITE, EMI (SMD)		D917	8-719-200-82	DIODE 11ES2	
C853	1-162-970-11	CERAMIC CHIP	0.01uF 10% 25V	D918	8-719-200-82	DIODE 11ES2	
C901	1-135-473-21	ELECT	3300uF 20% 16V	D919	8-719-200-82	DIODE 11ES2	
C902	1-164-156-11	CERAMIC CHIP	0.1uF 25V	D920	8-719-053-18	DIODE 1SR154-400TE-25	
C904	1-126-160-11	ELECT	1uF 20% 50V	D921	8-719-053-18	DIODE 1SR154-400TE-25	
C905	1-164-156-11	CERAMIC CHIP	0.1uF 25V	D922	8-719-200-82	DIODE 11ES2	
C907	1-162-970-11	CERAMIC CHIP	0.01uF 10% 25V	D923	8-719-110-14	DIODE RD9.1ES-B3	
C909	1-164-156-11	CERAMIC CHIP	0.1uF 25V	D930	8-719-109-89	DIODE RD5.6ES-B2	
C913	1-164-156-11	CERAMIC CHIP	0.1uF 25V	D931	8-719-988-61	DIODE 1SS355TE-17	
C914	1-104-665-11	ELECT	100uF 20% 10V	D932	8-719-988-61	DIODE 1SS355TE-17	
C915	1-110-654-11	DOUBLE LAYERS	0.047F 5.5V	D933	8-719-200-82	DIODE 11ES2	
C916	1-164-156-11	CERAMIC CHIP	0.1uF 25V	D934	8-719-200-82	DIODE 11ES2	
C919	1-124-229-00	ELECT	33uF 20% 10V	D955	8-719-988-61	DIODE 1SS355TE-17	
C920	1-124-584-00	ELECT	100uF 20% 10V	D999	8-719-991-33	DIODE 1SS133T-77	
C931	1-164-156-11	CERAMIC CHIP	0.1uF 25V			< JUMPER RESISTOR >	
C932	1-162-964-11	CERAMIC CHIP	0.001uF 10% 50V				
C951	1-162-964-11	CERAMIC CHIP	0.001uF 10% 50V	FB701	1-216-864-11	METAL CHIP 0 5% 1/10W	
C952	1-162-964-11	CERAMIC CHIP	0.001uF 10% 50V	FB702	1-216-864-11	METAL CHIP 0 5% 1/10W	
C960	1-216-864-11	METAL CHIP	0 5% 1/10W			< IC >	
		< JACK >		IC101	8-759-827-14	IC TA8268AH	
CNJ601	1-793-598-11	JACK (ANTENNA)		IC401	6-703-304-01	IC BD3802F-FE2	
CNP802	1-764-270-21	JACK, STEREO MINIATURE (DIA.3.5)	(REMOTE IN)	IC601	8-759-586-59	IC TB2118F-EL-S	
		< CONNECTOR >		IC801	6-802-553-01	IC uPD780076YGK-R24-9ET	
CNP701	1-815-260-11	CONNECTOR, BOARD TO BOARD 30P		IC902	8-759-837-07	IC S7139SF	
CNP803	1-569-907-11	SOCKET, CONNECTOR 12P				< JUMPER RESISTOR >	
CNP901	1-774-701-21	PIN, CONNECTOR 16P		JR411	1-216-864-11	METAL CHIP 0 5% 1/10W	
		< SURGE PROTECTOR >		JR412	1-216-864-11	METAL CHIP 0 5% 1/10W	
CP601	1-803-902-21	PROTECTOR CHIP, SURGE		JR605	1-216-864-11	METAL CHIP 0 5% 1/10W	
		< DIODE >		JR606	1-216-864-11	METAL CHIP 0 5% 1/10W	
D402	8-719-988-61	DIODE 1SS355TE-17		JR801	1-216-864-11	METAL CHIP 0 5% 1/10W	
D444	8-719-988-61	DIODE 1SS355TE-17		JR802	1-216-864-11	METAL CHIP 0 5% 1/10W	
D604	8-719-109-85	DIODE RD5.1ES-B2		JR805	1-216-864-11	METAL CHIP 0 5% 1/10W	
D801	8-719-991-33	DIODE 1SS133T-77		JR806	1-216-864-11	METAL CHIP 0 5% 1/10W	
D802	8-719-978-33	DIODE DTZ-TT11-6.8B		JR807	1-216-864-11	METAL CHIP 0 5% 1/10W	
D803	8-719-109-97	DIODE RD6.8ES-B2		JR808	1-216-864-11	METAL CHIP 0 5% 1/10W	
				JR809	1-216-864-11	METAL CHIP 0 5% 1/10W	
				JR810	1-216-295-11	SHORT CHIP 0	
				JR814	1-216-864-11	METAL CHIP 0 5% 1/10W	
				JR901	1-216-864-11	METAL CHIP 0 5% 1/10W	

CDX-L510X

MAIN

Ref. No.	Part No.	Description	Remark	Ref. No.	Part No.	Description	Remark
		< COIL >					
L601	1-410-508-11	INDUCTOR	8.2uH	R110	1-216-809-11	METAL CHIP	100 5% 1/10W
L603	1-412-006-31	INDUCTOR	10uH	R111	1-218-882-11	RES-CHIP	30K 0.5% 1/10W
L604	1-410-750-41	INDUCTOR	0.47uH	R112	1-216-845-11	METAL CHIP	100K 5% 1/10W
L669	1-424-759-21	COIL (AM ANT)		R115	1-216-833-11	METAL CHIP	10K 5% 1/10W
L701	1-410-513-11	INDUCTOR	22uH	R116	1-216-833-11	METAL CHIP	10K 5% 1/10W
L702	1-410-513-11	INDUCTOR	22uH	R201	1-216-833-11	METAL CHIP	10K 5% 1/10W
L901	1-419-476-31	COIL, CHOKE	250uH	R202	1-216-833-11	METAL CHIP	10K 5% 1/10W
		< JACK >		R207	1-216-841-11	METAL CHIP	47K 5% 1/10W
PJ401	1-774-698-11	JACK, PIN 2P (AUDIO OUT)		R208	1-216-841-11	METAL CHIP	47K 5% 1/10W
		< TRANSISTOR >		R209	1-216-809-11	METAL CHIP	100 5% 1/10W
Q101	8-729-920-21	TRANSISTOR	DTC314TK-T-146	R210	1-216-809-11	METAL CHIP	100 5% 1/10W
Q102	8-729-920-21	TRANSISTOR	DTC314TK-T-146	R401	1-216-833-11	METAL CHIP	10K 5% 1/10W
Q201	8-729-920-21	TRANSISTOR	DTC314TK-T-146	R404	1-216-821-11	METAL CHIP	1K 5% 1/10W
Q202	8-729-920-21	TRANSISTOR	DTC314TK-T-146	R407	1-249-437-11	CARBON	47K 5% 1/4W
Q401	8-729-055-92	TRANSISTOR	SRA2203SF	R408	1-216-827-11	METAL CHIP	3.3K 5% 1/10W
Q402	8-729-055-96	TRANSISTOR	SRC1203SF	R410	1-216-805-11	METAL CHIP	47 5% 1/10W
Q603	8-729-030-51	TRANSISTOR	2SA1515S-R-TP	R601	1-249-417-11	CARBON	1K 5% 1/4W
Q604	8-729-055-96	TRANSISTOR	SRC1203SF	R602	1-216-821-11	METAL CHIP	1K 5% 1/10W
Q605	8-729-030-51	TRANSISTOR	2SA1515S-R-TP	R603	1-249-407-11	CARBON	150 5% 1/4W
Q606	8-729-055-96	TRANSISTOR	SRC1203SF	R604	1-216-821-11	METAL CHIP	1K 5% 1/10W
Q801	8-729-055-92	TRANSISTOR	SRA2203SF	R605	1-216-841-11	METAL CHIP	47K 5% 1/10W
Q833	8-729-049-40	TRANSISTOR	2SC5343SFG	R606	1-216-841-11	METAL CHIP	47K 5% 1/10W
Q834	8-729-055-96	TRANSISTOR	SRC1203SF	R607	1-216-827-11	METAL CHIP	3.3K 5% 1/10W
Q902	8-729-049-40	TRANSISTOR	2SC5343SFG	R608	1-216-833-11	METAL CHIP	10K 5% 1/10W
Q903	8-729-055-96	TRANSISTOR	SRC1203SF	R609	1-216-809-11	METAL CHIP	100 5% 1/10W
Q904	8-729-055-96	TRANSISTOR	SRC1203SF	R610	1-216-809-11	METAL CHIP	100 5% 1/10W
Q905	8-729-055-96	TRANSISTOR	SRC1203SF	R611	1-218-867-11	METAL CHIP	6.8K 5% 1/10W
Q906	8-729-055-92	TRANSISTOR	SRA2203SF	R612	1-216-833-11	METAL CHIP	10K 5% 1/10W
Q907	8-729-021-82	TRANSISTOR	2SD2396K	R613	1-216-833-11	METAL CHIP	10K 5% 1/10W
Q908	8-729-055-92	TRANSISTOR	SRA2203SF	R614	1-249-409-11	CARBON	220 5% 1/4W
Q909	8-729-055-96	TRANSISTOR	SRC1203SF	R615	1-216-825-11	METAL CHIP	2.2K 5% 1/10W
Q910	8-729-920-85	TRANSISTOR	2SD1664-QR	R616	1-216-845-11	METAL CHIP	100K 5% 1/10W
Q911	8-729-055-96	TRANSISTOR	SRC1203SF	R617	1-216-825-11	METAL CHIP	2.2K 5% 1/10W
Q912	8-729-055-92	TRANSISTOR	SRA2203SF	R618	1-216-845-11	METAL CHIP	100K 5% 1/10W
Q913	8-729-019-00	TRANSISTOR	2SD2394-G	R619	1-216-817-11	METAL CHIP	470 5% 1/10W
Q914	8-729-055-96	TRANSISTOR	SRC1203SF	R620	1-216-817-11	METAL CHIP	470 5% 1/10W
Q915	8-729-049-43	TRANSISTOR	STB1132Y	R622	1-216-817-11	METAL CHIP	470 5% 1/10W
Q916	8-729-049-43	TRANSISTOR	STB1132Y	R628	1-216-829-11	METAL CHIP	4.7K 5% 1/10W
Q917	8-729-820-46	TRANSISTOR	2SB1202FAS	R704	1-216-821-11	METAL CHIP	1K 5% 1/10W
Q918	8-729-055-92	TRANSISTOR	SRA2203SF	R705	1-216-821-11	METAL CHIP	1K 5% 1/10W
Q919	8-729-920-85	TRANSISTOR	2SD1664-QR	R706	1-216-813-11	METAL CHIP	220 5% 1/10W
Q920	8-729-920-85	TRANSISTOR	2SD1664-QR	R707	1-216-849-11	METAL CHIP	220K 5% 1/10W
Q921	8-729-055-96	TRANSISTOR	SRC1203SF	R708	1-216-821-11	METAL CHIP	1K 5% 1/10W
Q922	8-729-055-96	TRANSISTOR	SRC1203SF	R709	1-216-821-11	METAL CHIP	1K 5% 1/10W
Q929	8-729-055-96	TRANSISTOR	SRC1203SF	R710	1-216-821-11	METAL CHIP	1K 5% 1/10W
		< RESISTOR >		R711	1-216-821-11	METAL CHIP	1K 5% 1/10W
R101	1-216-833-11	METAL CHIP	10K 5% 1/10W	R712	1-216-821-11	METAL CHIP	1K 5% 1/10W
R102	1-216-809-11	METAL CHIP	100 5% 1/10W	R714	1-216-825-11	METAL CHIP	2.2K 5% 1/10W
R103	1-216-809-11	METAL CHIP	100 5% 1/10W	R716	1-216-825-11	METAL CHIP	2.2K 5% 1/10W
R104	1-216-833-11	METAL CHIP	10K 5% 1/10W	R801	1-216-809-11	METAL CHIP	100 5% 1/10W
R107	1-216-841-11	METAL CHIP	47K 5% 1/10W	R802	1-216-809-11	METAL CHIP	100 5% 1/10W
R108	1-216-841-11	METAL CHIP	47K 5% 1/10W	R803	1-216-849-11	METAL CHIP	220K 5% 1/10W
R109	1-216-809-11	METAL CHIP	100 5% 1/10W	R806	1-249-417-11	CARBON	1K 5% 1/4W
				R807	1-216-849-11	METAL CHIP	220K 5% 1/10W
				R809	1-216-849-11	METAL CHIP	220K 5% 1/10W
				R810	1-249-417-11	CARBON	1K 5% 1/4W
				R811	1-249-417-11	CARBON	1K 5% 1/4W
				R812	1-249-417-11	CARBON	1K 5% 1/4W

MAIN

RELAY

SERVO

Ref. No.	Part No.	Description	Remark	Ref. No.	Part No.	Description	Remark
R814	1-216-809-11	METAL CHIP	100 5% 1/10W			< SWITCH >	
R815	1-216-809-11	METAL CHIP	100 5% 1/10W				
R816	1-216-841-11	METAL CHIP	47K 5% 1/10W	SW801	1-786-458-11	SWITCH, PUSH (1 KEY) (NOSE DET)	
R817	1-208-806-11	RES-CHIP	10K 0.5% 1/10W	SW802	1-762-638-21	SWITCH, TACTILE (RESET)	
R818	1-216-841-11	METAL CHIP	47K 5% 1/10W			< THERMISTOR >	
R819	1-216-849-11	METAL CHIP	220K 5% 1/10W				
R821	1-249-433-11	CARBON	22K 5% 1/4W	TH901	1-809-148-11	THERMISTOR PTH8L07AR2R0M1B510	
R822	1-216-849-11	METAL CHIP	220K 5% 1/10W			< TUNER >	
R823	1-249-417-11	CARBON	1K 5% 1/4W				
R824	1-216-849-11	METAL CHIP	220K 5% 1/10W	TU601	A-3220-835-A	TUNER UNIT (TUX-010)	
R832	1-216-849-11	METAL CHIP	220K 5% 1/10W			< VIBRATOR >	
R833	1-216-849-11	METAL CHIP	220K 5% 1/10W				
R835	1-216-836-11	METAL CHIP	18K 5% 1/10W	X601	1-781-246-21	VIBRATOR, CRYSTAL (10.25MHz)	
R836	1-249-425-11	CARBON	4.7K 5% 1/4W	X801	1-795-259-11	VIBRATOR, CERAMIC (8.38MHz)	
R840	1-216-809-11	METAL CHIP	100 5% 1/10W	X802	1-567-098-41	VIBRATOR, CRYSTAL (32kHz)	
R841	1-216-809-11	METAL CHIP	100 5% 1/10W	*****			
R842	1-216-821-11	METAL CHIP	1K 5% 1/10W			RELAY BOARD	
R847	1-216-809-11	METAL CHIP	100 5% 1/10W			*****	
R850	1-216-845-11	METAL CHIP	100K 5% 1/10W				
R855	1-216-821-11	METAL CHIP	1K 5% 1/10W			1-792-173-11	CABLE, FLAT (FFC) 12P (CNP903)
R856	1-249-409-11	CARBON	220 5% 1/4W			< CONNECTOR >	
R857	1-249-409-11	CARBON	220 5% 1/4W				
R858	1-216-841-11	METAL CHIP	47K 5% 1/10W	CNP902	1-817-159-11	SOCKET, CONNECTOR 14P	
R859	1-216-809-11	METAL CHIP	100 5% 1/10W			< DIODE >	
R860	1-216-813-11	METAL CHIP	220 5% 1/10W				
R901	1-249-425-11	CARBON	4.7K 5% 1/4W	LED930	8-719-082-38	LED CL-270SR-C-TS (CD WINDOW)	
R906	1-249-425-11	CARBON	4.7K 5% 1/4W	LED931	8-719-053-09	LED SML-310VTT86 (▲)	
R907	1-216-841-11	METAL CHIP	47K 5% 1/10W			< RESISTOR >	
R908	1-216-841-11	METAL CHIP	47K 5% 1/10W	R930	1-216-823-11	METAL CHIP	1.5K 5% 1/10W
R909	1-216-828-11	METAL CHIP	3.9K 5% 1/10W	R931	1-216-823-11	METAL CHIP	1.5K 5% 1/10W
R913	1-249-417-11	CARBON	1K 5% 1/4W	R932	1-216-823-11	METAL CHIP	1.5K 5% 1/10W
R914	1-216-821-11	METAL CHIP	1K 5% 1/10W			< SWITCH >	
R916	1-249-413-11	CARBON	470 5% 1/4W				
R917	1-249-409-11	CARBON	220 5% 1/4W	S931	1-771-884-11	SWITCH, TACTILE (WITH LED) (▲)	
R918	1-216-845-11	METAL CHIP	100K 5% 1/10W	*****			
R919	1-249-421-11	CARBON	2.2K 5% 1/4W			A-3283-233-A	SERVO BOARD, COMPLETE
R920	1-216-849-11	METAL CHIP	220K 5% 1/10W			*****	
R922	1-208-806-11	RES-CHIP	10K 0.5% 1/10W				
R923	1-208-806-11	RES-CHIP	10K 0.5% 1/10W			1-683-284-11	FLEXIBLE BOARD
R924	1-249-404-00	CARBON	82 5% 1/4W			< CAPACITOR >	
R925	1-249-404-00	CARBON	82 5% 1/4W	C1	1-162-970-11	CERAMIC CHIP	0.01uF 10% 25V
R926	1-249-404-00	CARBON	82 5% 1/4W	C3	1-162-970-11	CERAMIC CHIP	0.01uF 10% 25V
R927	1-249-404-00	CARBON	82 5% 1/4W	C4	1-104-609-11	ELECT CHIP	100uF 20% 4V
R928	1-249-404-00	CARBON	82 5% 1/4W	C5	1-162-970-11	CERAMIC CHIP	0.01uF 10% 25V
R929	1-249-404-00	CARBON	82 5% 1/4W	C6	1-162-970-11	CERAMIC CHIP	0.01uF 10% 25V
R930	1-216-845-11	METAL CHIP	100K 5% 1/10W	C8	1-107-826-11	CERAMIC CHIP	0.1uF 10% 16V
R931	1-249-421-11	CARBON	2.2K 5% 1/4W	C9	1-162-924-11	CERAMIC CHIP	56PF 5% 50V
R932	1-249-421-11	CARBON	2.2K 5% 1/4W	C10	1-162-924-11	CERAMIC CHIP	56PF 5% 50V
R933	1-216-821-11	METAL CHIP	1K 5% 1/10W	C11	1-162-909-11	CERAMIC CHIP	4PF 0.25PF 50V
R934	1-216-041-00	METAL CHIP	470 5% 1/10W	C13	1-162-916-11	CERAMIC CHIP	12PF 5% 50V
R935	1-249-395-11	CARBON	15 5% 1/4W	C14	1-125-837-11	CERAMIC CHIP	1uF 10% 6.3V
R936	1-218-867-11	METAL CHIP	6.8K 5% 1/10W	C15	1-162-970-11	CERAMIC CHIP	0.01uF 10% 25V
R937	1-216-041-00	METAL CHIP	470 5% 1/10W	C16	1-162-970-11	CERAMIC CHIP	0.01uF 10% 25V
R951	1-216-821-11	METAL CHIP	1K 5% 1/10W	C17	1-162-970-11	CERAMIC CHIP	0.01uF 10% 25V
R952	1-216-809-11	METAL CHIP	100 5% 1/10W	C18	1-162-966-11	CERAMIC CHIP	0.0022uF 10% 50V
R953	1-216-809-11	METAL CHIP	100 5% 1/10W				

CDX-L510X

SERVO	SL SW	SPEAKER
--------------	--------------	----------------

Ref. No.	Part No.	Description	Remark
C19	1-107-826-11	CERAMIC CHIP 0.1uF 10%	16V
C20	1-107-826-11	CERAMIC CHIP 0.1uF 10%	16V
C21	1-162-970-11	CERAMIC CHIP 0.01uF 10%	25V
C22	1-162-970-11	CERAMIC CHIP 0.01uF 10%	25V
C23	1-162-970-11	CERAMIC CHIP 0.01uF 10%	25V
C24	1-162-970-11	CERAMIC CHIP 0.01uF 10%	25V
C25	1-162-970-11	CERAMIC CHIP 0.01uF 10%	25V
C26	1-126-391-11	ELECT CHIP 47uF 20%	6.3V
C27	1-162-970-11	CERAMIC CHIP 0.01uF 10%	25V
C29	1-162-970-11	CERAMIC CHIP 0.01uF 10%	25V
C30	1-162-970-11	CERAMIC CHIP 0.01uF 10%	25V
C34	1-162-970-11	CERAMIC CHIP 0.01uF 10%	25V
C35	1-162-970-11	CERAMIC CHIP 0.01uF 10%	25V
C36	1-162-970-11	CERAMIC CHIP 0.01uF 10%	25V
C37	1-126-393-11	ELECT CHIP 33uF 20%	10V
C38	1-162-970-11	CERAMIC CHIP 0.01uF 10%	25V
C40	1-107-826-11	CERAMIC CHIP 0.1uF 10%	16V
C41	1-162-970-11	CERAMIC CHIP 0.01uF 10%	25V
C43	1-162-967-11	CERAMIC CHIP 0.0033uF 10%	50V
C44	1-125-837-11	CERAMIC CHIP 1uF 10%	6.3V
C45	1-162-970-11	CERAMIC CHIP 0.01uF 10%	25V
< CONNECTOR >			
CN1	1-815-352-11	CONNECTOR, BOARD TO BOARD 30P	
CN3	1-816-275-21	CONNECTOR, FFC/FPC 6P	
< JUMPER RESISTOR >			
FB1	1-216-864-11	METAL CHIP 0 5%	1/10W
< IC >			
IC1	8-759-699-98	IC uPD63711GC-8EU	
IC2	8-759-658-87	IC BA5810FP-E2	
< TRANSISTOR >			
Q1	8-729-904-87	TRANSISTOR 2SB1197K-R	
< RESISTOR >			
R3	1-216-797-11	METAL CHIP 10 5%	1/10W
R5	1-218-344-11	METAL CHIP 7.5K 5%	1/10W
R7	1-216-839-11	METAL CHIP 33K 5%	1/10W
R8	1-216-833-11	METAL CHIP 10K 5%	1/10W
R9	1-216-840-11	METAL CHIP 39K 5%	1/10W
R10	1-216-835-11	METAL CHIP 15K 5%	1/10W
R12	1-216-837-11	METAL CHIP 22K 5%	1/10W
R14	1-216-841-11	METAL CHIP 47K 5%	1/10W
R15	1-216-841-11	METAL CHIP 47K 5%	1/10W
R17	1-216-809-11	METAL CHIP 100 5%	1/10W
R18	1-216-809-11	METAL CHIP 100 5%	1/10W
R19	1-216-809-11	METAL CHIP 100 5%	1/10W
R20	1-216-809-11	METAL CHIP 100 5%	1/10W
R21	1-216-821-11	METAL CHIP 1K 5%	1/10W
R22	1-216-821-11	METAL CHIP 1K 5%	1/10W
R26	1-216-797-11	METAL CHIP 10 5%	1/10W
R29	1-216-833-11	METAL CHIP 10K 5%	1/10W
R30	1-216-833-11	METAL CHIP 10K 5%	1/10W

Ref. No.	Part No.	Description	Remark
< VIBRATOR >			
X1	1-795-520-11	VIBRATOR, CERAMIC (16.9344MHz)	

	1-683-282-11	SL SW BOARD	

< SWITCH >			
SW4	1-529-565-41	SWITCH, PUSH (1 KEY) (LIMIT)	

	A-3274-646-A	SPEAKER BOARD, COMPLETE (supplied with MAIN BOARD, COMPLETE)	

MISCELLANEOUS			

9	1-776-206-21	CORD (WITH CONNECTOR) (POWER)	
201	X-3378-480-1	CHASSIS (OP) ASSY (including M901)	
207	1-823-641-11	CABLE, FLEXIBLE FLAT (6 CORE)	
△210	8-820-165-06	OPTICAL PICK-UP KSS-721A/C-RP	
F901	1-532-877-11	FUSE (BLADE TYPE) (AUTO FUSE) 10A	
M902	A-3301-985-A	MOTOR ASSY, SLED (SLED)	
M903	A-3315-039-A	MOTOR SUB ASSY, LO (LOADING)	

ACCESSORIES			

	1-476-526-34	REMOTE COMMANDER (RM-X115)	
	3-230-047-01	LID, BATTERY CASE (for RM-X115)	
	3-247-734-11	MANUAL, INSTRUCTION (ENGLISH,FRENCH)	
	3-247-736-11	MANUAL, INSTRUCTION, INSTALL (ENGLISH, FRENCH)	
	X-3378-390-3	CASE ASSY (for FRONT PANEL)	

<p>The components identified by mark △ or dotted line with mark △ are critical for safety. Replace only with part number specified.</p>	<p>Les composants identifiés par une marque △ sont critiques pour la sécurité. Ne les remplacer que par une pièce portant le numéro spécifié.</p>
---	---

Ref. No.	Part No.	Description	Remark
PARTS FOR INSTALLATION AND CONNECTIONS			

251	X-3382-647-1	FRAME ASSY, FITTING	
252	3-934-325-01	SCREW (+K 5X8 TP)	
253	3-246-035-01	COLLAR	
254	1-776-206-21	CORD (WITH CONNECTOR) (POWER)	
255	3-246-471-01	KEY (FRAME)	

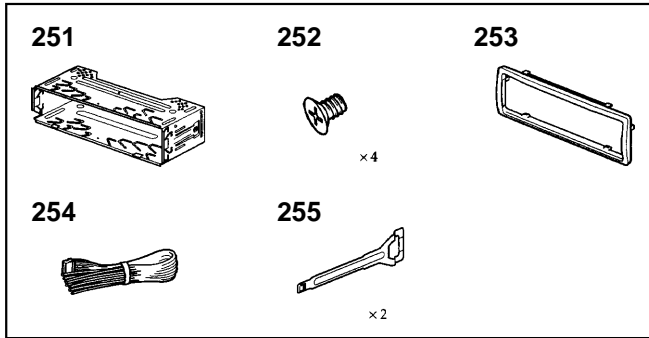

CDX-L510X

MEMO

CDX-L510X

SONY®

US Model
Canadian Model

SERVICE MANUAL

Ver 1.1 2003.06

SUPPLEMENT-1

File this supplement with the service manual.

Subject : Change of optical pick-up block

The optical pick-up block have been changed in the process of production.
Confirm an optical pick-up block pattern name when you exchange optical pick-up block.

Discrimination

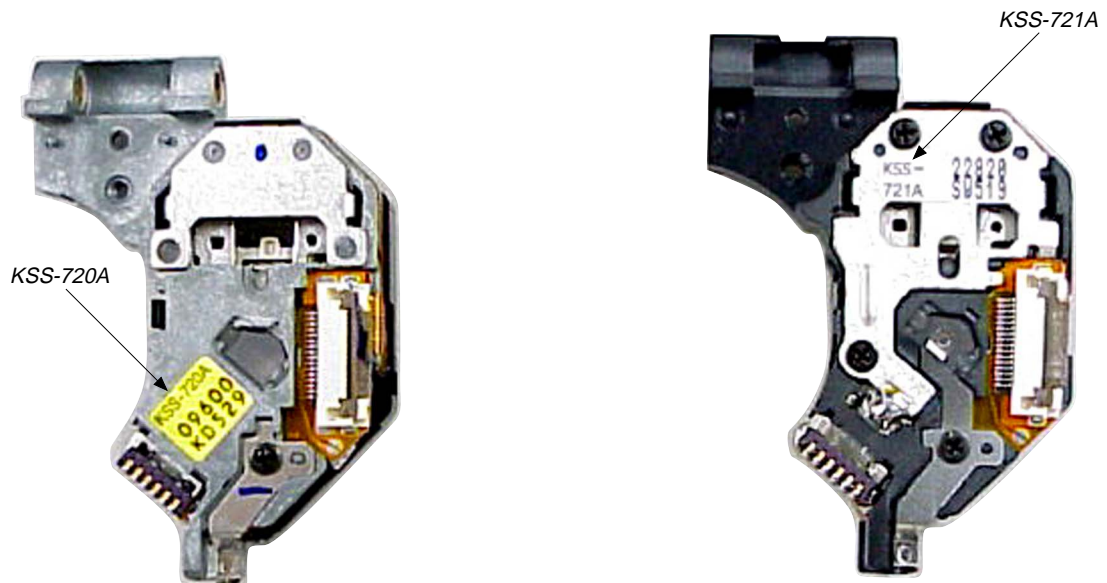

CDX-L510X

Parts List

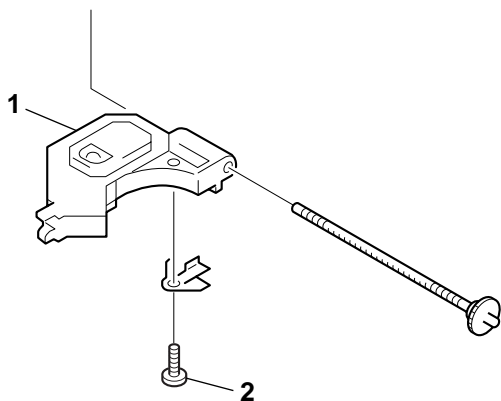

Ref. No.	Part No.	Description	Remark
△ 1	8-820-103-11	OPTICAL PICK-UP KSS-720A/C-RP	
△ 1	8-820-165-06	OPTICAL PICK-UP KSS-721A/C-RP	
2	7-627-553-37	PRECISION SCREW +P 2X3 TYPE3	(for KSS-720A)
2	3-909-607-01	SCREW (for KSS-721A)	

The components identified by mark △ or dotted line with mark △ are critical for safety. Replace only with part number specified.

Les composants identifiés par une marque △ sont critiques pour la sécurité. Ne les remplacer que par une pièce portant le numéro spécifié.

MEMO

