

MULTI-CD CONTROL FM/MW/LW
TUNER DECK AMPLIFIER
/MULTI-COMPACT DISC PLAYER

UKW/MW/LW TUNERDECK-VERSTÄRKER
MIT STEUERUNG FÜR MULTI-CD
/MEHRPLATTEN-CD SPIELER

KEH-P20 KEH-P10
CDX-P22



OWNER'S MANUAL BEDIENUNGSANLEITUNG

Thank you for purchasing this PIONEER product. Before attempting operation, be sure to read this manual.

Vielen Dank für den Kauf dieses PIONEER Produkts. Diese Bedienungsanleitung vor der Inbetriebnahme sorgfältig durchlesen.



KEH-P20



CDX-P22

 **PIONEER**
The Art of Entertainment

ENGLISH

CONTENTS

Fig. 1 ~ Fig. 4	3
Precautions	4
Connecting the Units	4
Installation	7
Using the Clear Button	10
Using the Removable Front Panel	10
Switching power on	12
Adjusting Volume and Tone	12
Using the Radio	13
Using the Tape Deck	15
Playing Compact Discs	16
Specifications	23

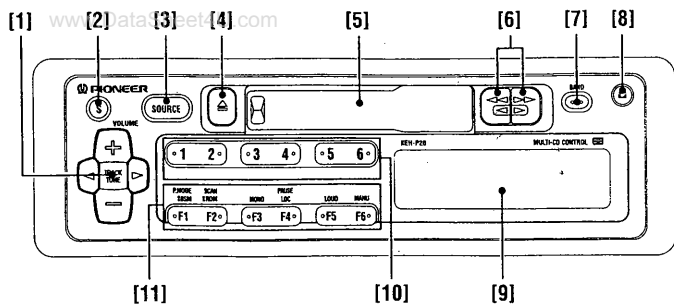

Fig. 1 Abb. 1

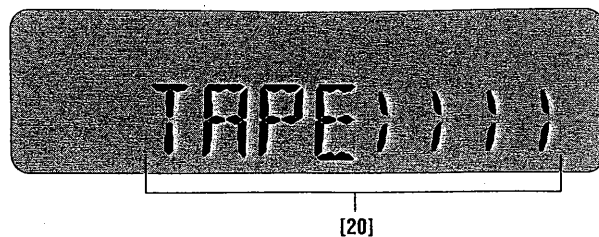

Fig. 3 Abb. 3

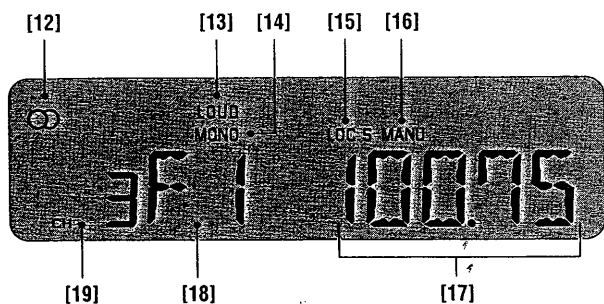

Fig. 2 Abb. 2

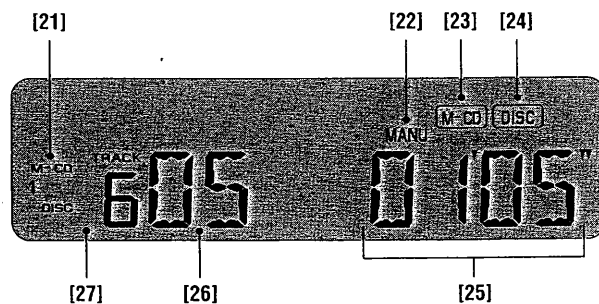

Fig. 4 Abb. 4

3

Precautions

Cassette player

- The "Pioneer CarStereo-Pass" can be used only in Germany.
- If the car's battery is disconnected for any reason, the preset memory will be erased and must be reprogrammed after reconnection of the battery.

Multi-play CD player

Note:

- A "CLASS 1 LASER PRODUCT" label is affixed to the rear of the player.



- When driving on an uneven road, the multi-play CD player may not reproduce every sound properly.
- During winter the inside of the vehicle may be very cold. If the heater is turned on and the multi-play CD player is used soon after, the disc or optical parts (prism, lens, etc.) may become misted up, and the multi-play CD player will not operate correctly. If the disc is misted up, wipe it with a soft cloth. If the optical parts are misted up, wait for about an hour for them to warm up. They will return to their normal condition.

In case of trouble

When the unit does not operate properly, contact your dealer or the nearest authorized PIONEER Service Station. Never remove the top case of the unit to attempt check or repairs.

Connecting the Units

Note:

- This system is for vehicles with a 12-volt battery and negative grounding. Before installing it in a recreational vehicle, truck, or bus, check the battery voltage.
- To avoid shorts in the electrical system, be sure to disconnect the battery \ominus cable before beginning installation.
- Be sure to press the clear buttons on the cassette player and the multi-play CD player with the tip of a pencil or something similar.
- Be sure to connect the ground lead (black) to the vehicle body or some other metal part that is properly grounded to the chassis. If the ground lead is not properly connected, noise may occur or this system may not operate correctly.
- Check whether installation and wiring have been completed correctly. Replace the removed car components, then connect the end of the cable to the negative \ominus terminal of the battery.

- Refer to the owner's manual for details on connecting the various cords of the power amp and other units, then make connections correctly.
- Secure the wiring with cable clamps or adhesive tape. To protect the wiring, wrap adhesive tape around them where they lie against metal parts.
- Route and secure all wiring so it cannot touch any moving parts, such as the gear shift, handbrake and seat rails. Do not route wiring in places that get hot, such as near the heater outlet. If the insulation of the wiring melts or gets torn, there is a danger of the wiring short-circuiting to the vehicle body.
- Don't pass the orange lead through a hole into the engine compartment to connect to the battery. This will damage the lead insulation and can cause a very dangerous short.
- Do not shorten any leads. If you do, the protection circuit may fail to work when it should.
- Never feed power to other equipment by cutting the insulation of the power supply lead of the system and tapping into the lead. The current capacity of the lead will be exceeded, causing over heating.

- When replacing fuses, be sure to use only fuse of the rating prescribed on the fuses holder.
- Since a unique BPTL circuit is employed, never wire so the speaker leads are directly grounded or the left and right speaker ⊖ leads are common.
- Speakers connected to this system must be high-power types possessing minimum rating of 35 W and impedance of 4 to 8 ohms. Connecting speakers with output and/or impedance values other than those noted here can damage the speakers.
- When connecting a power amp, never connect the blue lead to the amp's power supply terminal. Also, when connecting an auto antenna, never connect the blue lead to the antenna's power supply terminal. Such connections may cause damage due to excessive current.
- To prevent incorrect connection, the input side of the IP-BUS connector is blue, and the output side is black. Connect the connectors of the same colors correctly.

- When the system is mounted in a vehicle whose ignition switch does not have the ACC (accessory) position as shown in Fig. 6, be sure to connect the red lead of the unit to the terminal controlled by the ignition switch ON/OFF position. If you do not, the vehicle battery may go flat when you leave your vehicle for several hours.

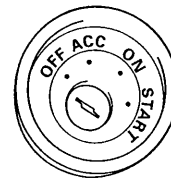

ACC position

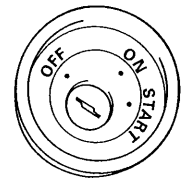

No ACC position

Fig. 5

Fig. 6

- This system cannot be combined with the separately available CD-P44 multiple installation adaptor.

Connection Diagram (Fig. 7)

- Cassette player
- Antenna jack
- Rear out
- White
- Red
- Connecting cords with RCA pin plugs (sold separately)
- Power amp (sold separately)
- Blue
- Multi-play CD player
- IP-BUS output (black)
- IP-BUS input (blue)
- Blue
- To system control terminal of the power amp or Auto-antenna relay control terminal. (Max. 300 mA 12 V DC).
- Black (ground)
- To vehicle (metal) body.
- Orange
- To terminal always supplied with power regardless of ignition switch position.
- Red
- To electric terminal controlled by ignition switch (12 V DC) ON/OFF.
- Fuse holder
- Fuse resistor
- With a 2 speaker system, connect to the 2 speakers in the front or the rear.
- Use this for connections when you have the separately available amplifier.
- Front/left speaker
- Front/right speaker
- Rear/left speaker
- Rear/right speaker
- Green
- Gray
- Green/black
- Gray/black
- Green/red
- Gray/red
- Black/green
- Black/gray

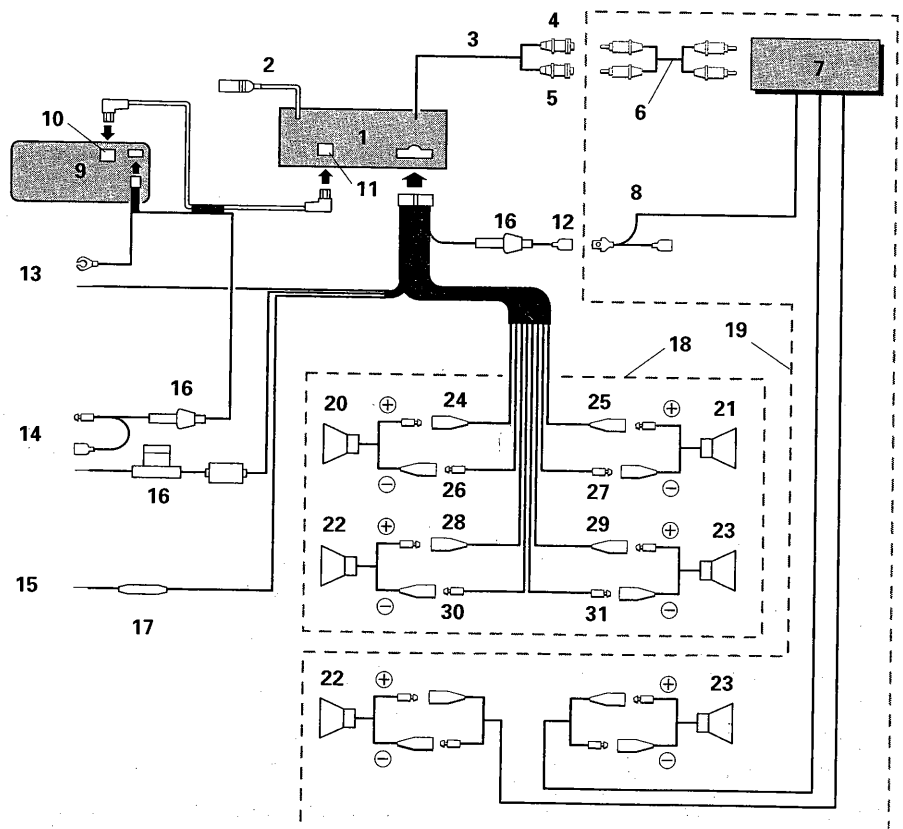

Installation

Note:

- Before finally installing the system, connect the wiring temporarily and make sure it is all connected up properly and the unit and the system work properly.
- Use only the parts included with the unit to ensure proper installation. The use of unauthorized parts can cause malfunctions.
- Consult with your nearest dealer if installation requires the drilling of holes or other modifications of the vehicle.
- Install the unit where it does not get in the driver's way and cannot injure the passenger if there is a sudden stop, like an emergency stop.
- If installation angle exceeds 30° from horizontal, cassette player might not give its optimum performance. (Fig. 8)

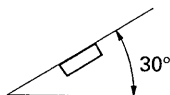

Fig. 8

Cassette player

Installation with the rubber bush

(Fig. 9)

1. Dashboard
2. Holder
After inserting the holder into the dashboard, select the appropriate tabs according to the thickness of the dashboard material and bend them inwards to secure the holder in place.
3. Rubber bush
4. Screw

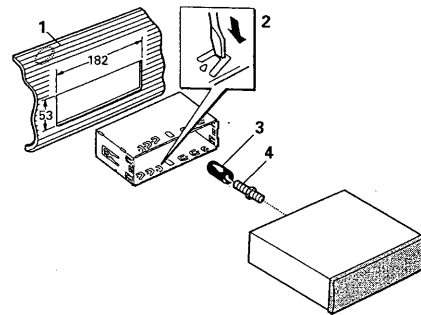

Fig. 9

Removing the unit

(Fig. 10)

5. Insert the supplied extraction keys into the unit, as shown in the figure, until they click into place. Keeping the keys pressed against the sides of the unit, pull the unit out.

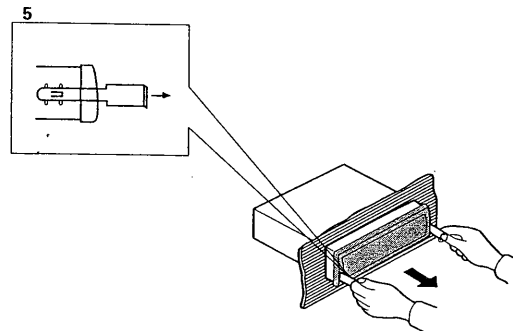

Fig. 10

Multi-play CD player

Location

- Install the unit where it does not get in the driver's way and cannot injure the passenger if there is a sudden stop, like an emergency stop.
- Be sure to mount the player on a rigid surface which is firm enough to hold the player in the proper position under all circumstances. Failure to do so may affect the optimum performance of the player.
- Before drilling a hole into the trunk, confirm that there is nothing behind the hole. Never drill a hole in the fuel tank or any other important part.
- Do not mount the player near the heater outlet, where it would be affected by heat, or near the doors, where rainwater might splash onto it.
- Do not mount the player on the spare tire board or any other unstable place.
- Mount the player in a place where it does not prevent the spare tire, jack, or tools from being easily removed.
- Do not mount the player anywhere that gets the sun and so becomes hot like on the dashboard or the rear shelf.
- Install this unit at the angle shown in Fig. 11, 12. In addition, choose a place where the CD magazine can be loaded and unloaded easily.

(Fig. 11)

- [1] Use any angle in this range (up to 90 degrees).
- [2] The player cannot be installed in this direction.

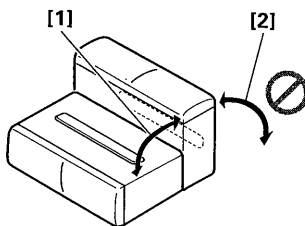

Fig. 11

(Fig. 12)

The player cannot be installed vertically like this. If it is positioned vertically, the magazine slot must face upward.

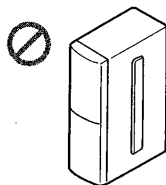

Fig. 12

Mounting the player on the mounting board with self-tapping screws

1. Using the screws (4 × 8 mm), fit the mounting brackets to the sides of the player so they face downward.

(Fig. 13) (Fig. 14)

- [1] Screw (4 × 8 mm)
 - [2] Mounting bracket
- When the player is installed horizontally, use the outer holes marked "H" to attach the mounting bracket.

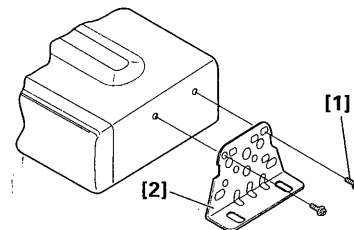

Fig. 13

- When the player is installed vertically, use the holes marked "V" to attach the mounting bracket.

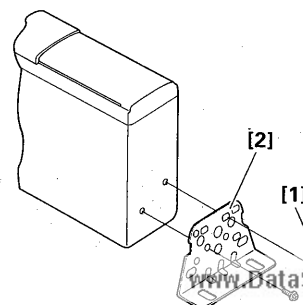

Fig. 14

2. Mount the player on the mounting board with the self-tapping screws (6 × 16 mm).

(Fig. 15) (Fig. 16)

[1] Self-tapping screws (6 × 16mm)

[2] Drill 4 to 4.5 mm diameter hole.

[3] Mounting board

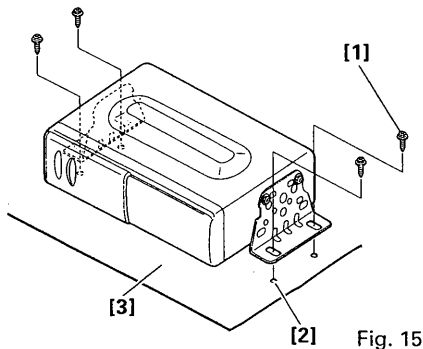

Fig. 15

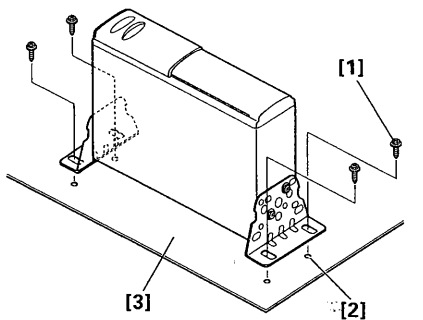

Fig. 16

Suspending the player from the parcel shelf with hex-screws

1. Using the screws (4 × 8 mm), fit the mounting brackets to the sides of the player so they face upward.

(Fig. 17)

[1] Screw (4 × 8 mm)

[2] Mounting bracket

• Use the holes marked "H" to attach the mounting brackets to the player.

2. Check the place of mounting and drill holes (6.5 to 7 mm diameter) through the parcel shelf.

3. Pass hex-screws (6 × 50 mm) through the holes from the passenger compartment side, fit them to the screw holes of the mounting bracket, and install with the hex-nuts.

(Fig. 18)

[1] Hex-nut (6 mm)

[2] Hex-screw (6 × 50 mm)

[3] Drill 6.5 to 7 mm diameter hole.

[4] Parcel shelf

• Ideally, when the player is being mounted under the parcel shelf, two persons should work together. One person should hold the player, and the other should tighten the hex-nuts. If you do this job on your own, take great care not to drop or knock the player.

• When suspending the player under the parcel shelf, be sure that it is firmly installed on a solid surface. If the unit is not firmly installed, skipping will occur.

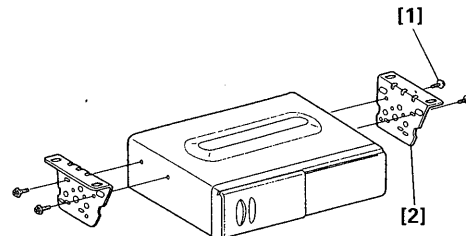

Fig. 17

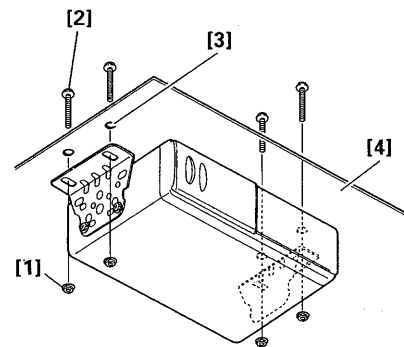

Fig. 18

Using the Clear Button

Once all wiring is complete, press clear button with a thin, pointed object. Though not a normal occurrence, the microprocessor which controls the operation of this unit can be affected by electrostatic noise. This generally is indicated by such symptoms as no power being supplied when you switch the unit on, failure of buttons and controls, or an abnormal display. Should this happen, press the clear buttons on the cassette player and the multi-play CD player with the tip of a pencil or something similar to reset their microcomputers.

Cassette player

• The clear button can be located on the unit after you have removed the front panel. (Fig. 19)

Refer to the previous page to find out how to remove the front panel.

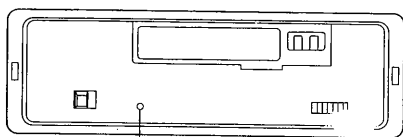

Clear Button

Fig. 19

Multi-play CD player

• Clear button is located inside the door. (Fig. 20)

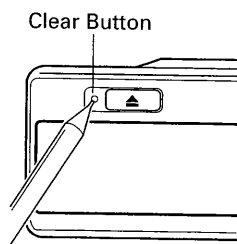

Fig. 20

Using the Removable Front Panel

The front panel of cassette player can be removed as a theft deterrent.

Parts Identification

Fig. 1

[4] Eject

[6] Fast forward, Rewind/Direction change

[8] Detach button

Detaching the Front Panel

1. Press button [8], and the right-hand side of the panel will eject.

2. To remove the front panel, pull its right-hand side toward you. (Fig. 21)

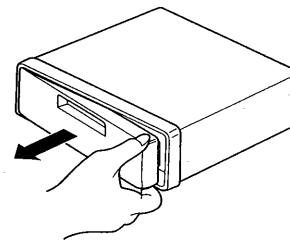

Fig. 21

• Take care not to put pressure on the display or drop the front panel.

3. Enclose for safekeeping the front panel that is removed in the supplied protective case. (Fig. 22)

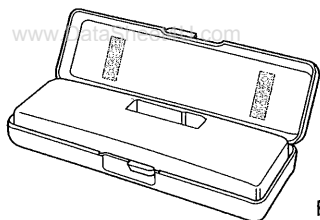

Fig. 22

Replacing the Front Panel

Push the front panel into the main body. (Fig. 23) (Fig. 24)

- When replacing the front panel, do not put pressure on the display or control buttons.

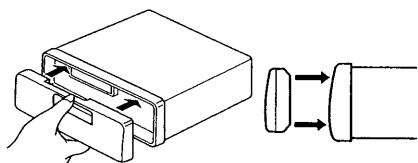

Fig. 23

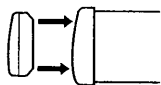

Fig. 24

- Install the front panel holding it parallel to the main unit. Installing the panel tilted, as shown in the illustrations below, may cause the hook on the front panel to destroy the main unit's electrodes. (Fig. 25) (Fig. 26) (Fig. 27)



Fig. 25



Fig. 26

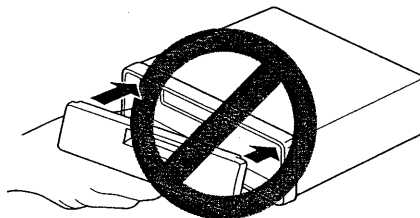

Fig. 27

- Do not install the front panel while holding down buttons [4], [6] and [8] in Fig. 1: Doing so may destroy the buttons and the main unit.
- Note that if the front panel is not attached correctly, pushing button [8] may not release the panel, and the other control buttons may not function.

Precautions

- Do not touch the contacts on the front panel or on the unit body, since this may result in poor electrical contact. If dirt or other foreign substances get on the contacts, wipe them with a clean, dry cloth. (Fig. 28) (Fig. 29)

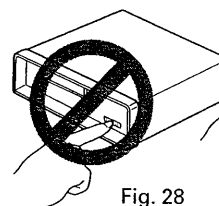

Fig. 28

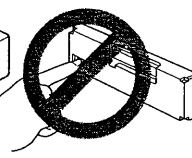

Fig. 29

Precautions When Handling the Front Panel

- Do not leave the front panel in any area exposed to high temperatures or direct sunlight.
- Do not drop the front panel or otherwise subject it to strong impact.
- Do not allow such volatile agents as benzene, thinner, or insecticides to come into contact with the surface of the front panel.
- Never try to disassemble the front panel.

Switching power on

Pasts Identification

Fig. 1

- [3] Source selector
- [5] Cassete door

Changing the Source

Each time you press button [3], the source changes as follows

Tape → Radio → Multi-play CD player → OFF

Tape

- When there is no cassette tape loaded in this unit, the source does not switch to Tape.
- The source switches to TAPE when a cassette is inserted into [5] on this unit.

Adjusting Volume and Tone

Parts Identification

Fig. 1

- [1] Volume/Audio adjustment
- [2] Shift
- [9] Display
- [11] Function buttons
- F5: Loudness

Fig. 2

- [13] Loudness

Mode Selection

Each press of button [2] changes the mode as follows:

Volume adjustment (VOL) → Balance adjustment (FAD/BAL) → Tone adjustment (BAS/TRE)

- When you are adjusting fader, balance, bass or treble settings, the indicator will stop at the center setting briefly.
- If no operations are performed within 8 seconds, adjustment modes are canceled. Make adjustments within 8 seconds.

Volume Adjustment

Pressing the (+) side of button [1] increases the volume, while the (-) side decreases it. (Display shows "VOL 00" ~ "VOL 30".)

- When driving your vehicle, be sure to keep the volume of the unit set low enough to allow you to hear sounds coming from outside.

Balance Adjustment

Press button [2] to select balance adjustment mode.

("FAD" appears on the display.) Adjust the fader using the (+) or (-) side of button [1]. To adjust the balance, press either the (◀) or (▶) side of button [1] will turn on "BAL". Then use the (◀) or (▶) side of the button to adjust balance.

Fader

When you press the (+) side of button [1], the front speaker volume increases gradually while the rear speaker volume decreases. When you press the (-) side of the button, the rear speaker volume increases gradually while the front speaker volume decreases.

(Display shows "FAD F15" ~ "FAD R15".)

- Please set "FAD 0" when using 2 speaker system.

Balance

Pressing the (◀) side of button [1] shifts the balance to the left speaker, while the (▶) side shifts it to the right speaker. (Display shows "BAL L9" ~ "BAL R9".)

Tone Adjustment

Press button [2] to select tone adjustment mode. ("BAS" appears.) Select the tone you wish to adjust using the (◀) or (▶) side of button [1]. Pressing the (▶) side boosts the TRE: pressing the (◀) side boosts the BAS.

Bass Adjustment

Select the Bass mode.

Pressing the (+) side of button [1] increases bass, while the (-) side decreases bass. (Display shows "BAS -6" ~ "BAS +6".)

Treble Adjustment

Select Treble adjustment mode.

Pressing the (+) side of button [1] increases treble, while the (-) side decreases treble. (Display shows "TRE -6" ~ "TRE +6".)

Loudness

This "loudness" function enhances both the high and low ranges of sound to give even more power to output even at low volume.

Press button F5 of Bank [11] to turn on the loudness function.

(The "LOUD" [13] indicator appears on the display [9].)

Press button F5 of Bank [11], the loudness function turns off.

Using the Radio**Parts Identification****Fig. 1**

- [1] Tuning
- [3] Source selector
- [7] Band
- [9] Display
- [10] Preset
- [11] Function buttons
 - F1: Best Stations Memory (BSM)
 - F3: FM stereo, mono
 - F4: Local station
 - F6: Manual

Fig. 2

- [12] FM stereo
- [14] FM mono
- [15] Local station
- [16] Manual
- [17] Frequency
- [18] Band
- [19] Preset number

Listening to the Radio**• Electronic Tuner**

Frequency allocation differs depending upon the area. This unit has been designed in accordance with the frequency allocations for Western Europe, Asia, the Middle and Near East, Africa, Australia and Oceania. Use in other areas may result in improper reception of AM.

1. Press button [3] to switch the radio power on.

2. Press button [7] to select a band.

F 1 → F 2 → F 3 → MW/LW

(FM1) (FM2) (FM3) (MW/LW)

Use the (◀) and (▶) sides of button [1] to change between MW (531 – 1,602 kHz) and LW (153 – 281 kHz).

3. Use seek tuning to tune in a frequency.

Press the (▶) side of button [1] to automatically tune in the next higher receivable frequency, and the (◀) side for a lower frequency.

4. Adjust volume and tone (see page 12).

5. Assign the tuned frequency to one of the buttons in Bank [10] (preset memory).

Press and hold down one of the buttons in Bank [10] for at least 2 seconds. The frequency is assigned to the selected button when the preset number [19] stops flashing on the display. Up to 18 FM stations (6 FM1 stations, 6 FM2 stations, 6 FM3 stations), and 6 MW/LW stations can be assigned to the preset memory buttons in Bank [10].

6. Once a frequency is assigned to a button in Bank [10], you just need to press that button to tune it in.

This also causes the number of the button pressed to appear at position [19] on the display.

Adjusting Seek Sensitivity

The seek tuning function of this tuner lets you select between a local setting for reception of strong stations only, and a DX (distant) setting for reception of weaker stations.

Switching between Local and DX (distant)

Press button F4 of Bank [11] to switch between Local and DX (distant) seek tuning. When "LOC.S" [15] is shown on the display, seek tuning is performed with the local seek sensitivity. Otherwise, seek tuning is performed with the DX seek sensitivity.

Manual Tuning

Use manual tuning when stations are too weak to be picked up by seek tuning.

1. Press the button F6 of Bank [11], and the "MANU" indication [16] lights.

2. Each press of the (▶) side of button [1] increases the frequency in 50 kHz steps in the FM band, 9 kHz in the MW band and 1 kHz in the LW band. Pressing the (◀) side of button [1] decreases the frequency. Holding down either side of button [1] changes the frequency at high speed.

Switching between FM Stereo and Mono

Generally, it is best to allow the ARC (Automatic Reception Control) function to automatically set the optimum listening conditions. When stereo broadcasting is received, "◉" [12] will appear on the display. When there is a large amount of noise, you can press button F3 of Bank [11] for clearer mono reception ("MONO" [14] will appear on the display).

BSM (Best Stations Memory)

This function automatically locates stronger stations and automatically assigns their frequencies to the buttons in Bank [10], from strongest to weakest. It comes in handy when trying to find local stations while driving.

1. Press button [7] and select a band.

2. Holding down button F1 of Bank [11] for about 2 seconds will start BSM search. At this time, "BSM" will flash on the display.

3. The frequency display will return once BSM search is complete, and frequencies are assigned to preset buttons.

- You can cancel BSM search by pressing button F1 of Bank [11] again.
- If there are fewer than 6 strong stations in the area, some of the preset buttons will not be assigned frequencies, so they will retain any frequencies assigned to them previously.
- BSM search may take as long as 30 seconds in areas where there are few strong stations.

Using the Tape Deck

Parts Identification

- Fig. 1
 [3] Source selector
 [4] Eject
 [5] Cassette door
 [6] Fast forward, Rewind/Direction change
 [9] Display

- Fig. 3
 [20] Tape play

About Cassette Tapes

- Do not use tapes longer than C-90-type (90 min.) cassettes. Longer tapes can interfere with tape transport.
- A loose or warped label on a cassette tape may interfere with the eject mechanism of the unit or cause the cassette to become jammed in the unit. Avoid using such tapes or remove such labels from the cassette before attempting use.

- Storing cassettes in areas directly exposed to sunlight or high temperatures can distort them and subsequently interfere with tape transport. (Fig. 30)

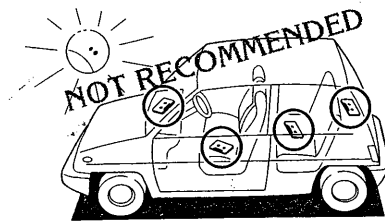

Fig. 30

- Store unused tapes in a tape case where there is no danger of them becoming loose or being exposed to dust.

Cleaning the Head

- If the head becomes dirty, the sound quality will deteriorate and there will be sound dropouts and other imperfections in performance. In this case, the head must be cleaned.
- When using a cleaning tape, play it once on one side for normal cleaning. Excessive use of the cleaning tape will increase head wear. Be sure to read the cleaning tape instructions before use.

Listening to a Tape

1. By inserting the cassette tape into slot [5], power will be turned on and the tape will begin to play.

At this time, the tape running, tape play indicator [20] will light up to your satisfaction.

2. Adjust volume and tone (see page 12).

3. To stop tape play, press button [3] to switch the source OFF, or press button [4] to eject the cassette.

- Do not try to eject the cassette immediately after insertion, as it may result in malfunction. Wait a few seconds.
- Be sure to eject the tape when the front panel is removed, or the vehicle's ignition is turned OFF. Leaving the tape in the unit can deform the pinch roller causing wow and flutter during tape playback.
- Loose tapes should be rewound with the aid of a pencil and unevenly wound tapes rewound with the use of the fast forward function.

Changing Program

Push the fast forward and rewind buttons [6] together to switch from one side of the tape to the other (from Side A to Side B or vice versa).

Using Fast Forward and Rewind

Since the transport can be in either direction, both the left and right high-speed tape transport buttons [6] can be regarded as fast forward/rewind buttons.

For fast forward, press the high-speed tape transport button [6] that corresponds to the direction that is shown by the tape play indicator [20]. When the end of the tape is reached, playback will automatically begin from the opposite side of the tape (Auto-reverse).

For rewind, press the button [6] that is opposite that of the direction shown by the tape play indicator [20]. When the end of the tape is reached, playback will automatically begin from the beginning of the same side of the tape (Auto-replay).

When you release fast forward/rewind, lightly press button [6] located on the opposite side of the one you pressed to fast forward or rewind.

- "<-->" [20] will flash when the tape is fast forwarding or rewinding.

Playing Compact Discs

Discs

- Only use compact discs (optical digital audio discs) bearing the mark shown in Fig. 31.



Fig. 31

- Be sure never to touch the signal surface when handling discs. Pick up discs by grasping the outer edges or the edges of the hole and the outer edge. (Fig. 32)

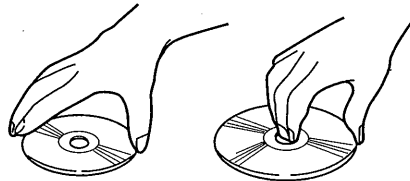

Fig. 32

- Do not affix paper or tape, and avoid scratching the side of the disc which contains the label (contents of disc).
- The disc revolves at high speed within the player unit, so defective (cracked or badly bent) discs should not be used.

- Dust and/or finger smudges will have no direct effect on the signal recorded on the disc, but dirt can decrease the amount of light reflected from the recorded surface, thus affecting sound quality. If the disc should become soiled, gently wipe the surface with a soft lint-free cloth, wiping from the center of the disc to the edge. (Fig. 33)

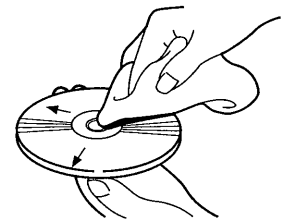

Fig. 33

- Do not use record sprays or antistatic agents. Such volatile chemicals as benzene and thinner can also damage the surface of the disc and should not be used.
- As with traditional audio records, compact discs are made of plastic. To avoid warping, keep the discs in their cases and do not store them in places exposed to direct sunlight.

Using the Compact Disc Magazine

Usable Magazines

- Only use magazines bearing the "8-disc" mark. If a magazine not bearing this mark is loaded, it may get stuck wide or the player may fail.

Precautions when handling magazines

- Do not put the magazine in a place where it will be exposed to high temperatures or direct sunlight.
- Do not disassemble the magazine.
- Take care not to drop the magazine or knock it against anything.
- Do not use cracked or warped trays.
- Never insert anything other than discs. Do not attach a label or tape to a disc.
- The use of benzine, thinner, insecticide, or other volatile chemicals may damage the magazine surface.

Extra magazines

If you need more magazines, please ask your nearest dealer for magazine JD-T612.

Notes on 8-cm (3-inch) CDs

- Do not use an 8-cm CD adapter. If it is used, the player may fail. To load an 8-cm CD, you need a special 8-cm CD tray (Part No. CXA5485). Ask your Pioneer service station about it.

Inserting discs

Load the discs in the magazine supplied. Up to 6 discs can be loaded in the magazine.

The discs are numbered 1 to 6 from the bottom disc tray.

1. Hold down the magazine lock button and, pull the tray out.

(Fig. 34)

[1] Lock button

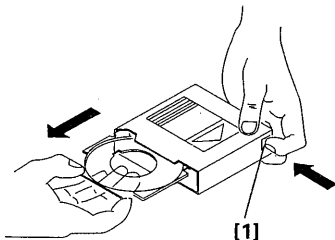

Fig. 34

- Pull the tray out by holding it from underneath as shown in the figure 34. The tray is detached from the magazine. Do not drop the tray or disc and so damage it.

2. Put 1 disc on the disc tray, label downward.

(Fig. 35)

[1] Position the disc with the label downward.

[2] Disc tray

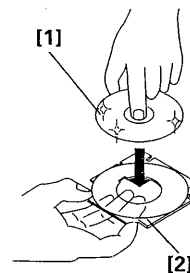

Fig. 35

- If the disc is loaded upside down, it will not play. The label side must face downward.
- Do not touch the recorded side of a disc when inserting or removing it.

3. Insert the tray horizontally along the right and left grooves of the magazine until it clicks. (The disc must not lift from the tray.)

(Fig. 36)

[1] Disc tray

[2] Groove

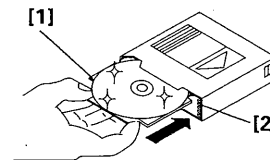

Fig. 36

17

- If the tray is not aligned with the right and left grooves, it cannot be pushed to the end. Do not bend or force the tray.
- Always load 6 trays in a magazine to prevent loss or warping of trays.
- If you load a disc with the label generally printed in black facing up, not only will the player not be able to recognize whether the disc is set or not, but also, if you have a cassette player, the controller will not display an error message to let you know about it. So make sure all the discs in each magazine have their label sides facing down.

Loading and removing the magazine

- Do not put your fingers in the magazine tray as this may lead to incorrect operation and damage to the player.

1. Slide and open the door. Open it fully until it locks with a click. (Fig. 37)

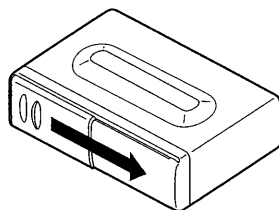

Fig. 37

2. Insert the magazine.

- Make sure that the magazine is loaded with discs before inserting it into the player.
- Be careful to insert the magazine into player with the mark facing upward.
- If the label on the magazine is coming off or wrinkled up, it may damage the eject mechanism, and in some cases, the magazine may not be ejected. Therefore, remove a damaged label completely before use.

(Fig. 38)

- [1] Insert the magazine with the arrow upward

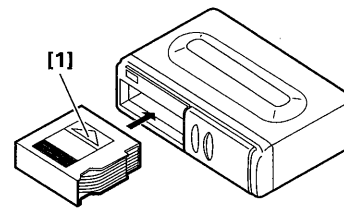

Fig. 38

3. Slide and close the door.

- Never leave the door open while playing discs. The entry of dirt, dust, or any other foreign matter into the player may cause it to fail. (Fig. 39)

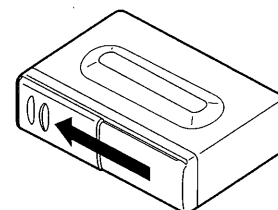

Fig. 39

4. To remove the magazine, open the door and press the eject button. If the door is not fully open, the magazine will not be ejected.

(Fig. 40)
[1] Eject button

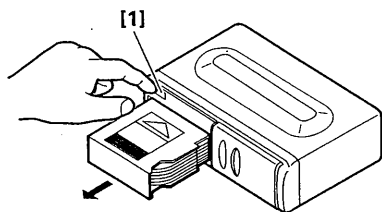

Fig. 40

Parts Identification

Fig. 1

- [1] Track number search/Fast forward, Reverse
- [3] Source selector
- [9] Display
- [10] Disc number search
- [11] Function buttons
 - F1: Play mode switching
 - F2: Scan play/Random play
 - F4: Pause
 - F6: Manual

Fig. 4

- [21] Multi-play CD player display
- [22] Manual
- [23] Magazine repeat mode display
- [24] Disc repeat mode display
- [25] Play elapse time display
- [26] Track number
- [27] Disc number

Using the Multi-Play CD Player

1. Press button [3] to change the display to the multi-play CD player mode and to begin disc play.

2. Use the Disc Number Search function to select a disc.

Select the desired disc by pressing one of the Disc number search buttons. The number of the disc selected appears at position [27] on the display.

- If the number at position [27] on the display does not change when you press a Disc number search button, it means that there is no disc loaded in that tray.

3. Adjust volume and tone (see page 12).

4. To stop disc play, press button [3].

At another press, the normal play resumes from about where it stopped.

Note:

- When you turn the power on or change the disc to be played, the multi-play CD player may perform a preparatory operation (verifying there is a disc, reading disc information, etc.). "READY" is displayed during this time.
- When the multi-play CD player is not working correctly, an error message appears on the display (Ex.: "ERROR-80"). (See page 22.)
- After you press a Disc number search button, it may take some time before play begins due to the time necessary to load and set the disc in the mechanism.

Track Number Search

The desired track on the disc currently being played can be selected by track (or song) number.

Confirm that Track Number is shown at Position [26] on the display.

Press the (▶) side of button [1] to increase the number at Position [26], or the (◀) side to decrease the number. Holding either side of button [1] changes the track number at high speed.

Using Fast Forward and Reverse

1. Press the button F6 of Bank [11], and the "MANU" indication [22] lights.
 2. Press the (▶) side of button [1] for fast forward, and the (◀) side for reverse.
- Sound is output during fast forward and reverse operations.

Repeat

You can select one of the play modes (repeat modes) listed below.

Play mode (repeat mode)	Operation
One-Track Repeat	Play the current track repeatedly. <ul style="list-style-type: none"> • When you perform track number search or fast forward or rewind, the mode changes to disc repeat mode. • Switching the disc switches to magazine repeat mode.
Disc Repeat	Play the same disc repeatedly. <ul style="list-style-type: none"> • Switching the disc switches to magazine repeat mode.
Magazine Repeat	Play all discs loaded in the magazine in the multi-play CD player repeatedly. All discs in the magazine are played repeatedly from the first disc.

Each press of button F1 of Bank [11] causes the mode to change as follows:

One-Track Repeat ("RPT" appears on the display [25]) → Disc Repeat ("DISC" [24] appears) → Magazine Repeat ("M-CD" [23] appears)

Random Play

The microcomputer of the multi-play CD player can play tracks on discs in a random order. Random play is performed according to the current play mode (repeat mode) as follows:

Play mode (repeat mode)	Tracks to be played at random
One-Track Repeat	All tracks on the disc being played. • The play mode changes to disc repeat mode.
Disc Repeat	All tracks on the disc being played.
Magazine Repeat	All tracks on the discs in the magazine being played.

1. Select the desired random play mode (repeat mode). (See page 20.)
2. Hold down button F2 of Bank [11] for more than 2 seconds. ("RDM" appears on the display [25].) To cancel random play, hold down button F2 of Bank [11] for more than 2 seconds again. ("RDM" disappears.)

Using Scan

The first parts of each track are played in succession for about 10 seconds. This function is useful to search for the track or disc you want to listen to. Scan is performed according to the current play mode (repeat mode) as follows:

Play mode (repeat mode)	Tracks to be scanned and played
One-Track Repeat	All tracks on the disc being played. • The play mode changes to disc repeat mode.
Disc Repeat	All tracks on the disc being played.
Magazine Repeat	The first tracks of all the discs in the magazine being played.

1. Select the desired scan play mode (repeat mode). (See page 20.)
2. Press button F2 of Bank [11]. ("SCAN" appears on the display [25].) The first parts of all tracks are played in succession for about 10 seconds.
3. When you hear the track you want, press button F2 of Bank [11] again to cancel Scan. ("SCAN" disappears.) The track (disc) being played then plays to the end.
• The previous function automatically resumes when a piece of music with which Scan began returns.

Pausing

1. Press button F4 of Bank [11] to pause during disc playback ("PAUSE" appears on display [25]).
 2. Press button F4 of Bank [11] again to release pause.
- You can select a track using the track number search during pause. ("PAUSE" is off while a track is being searched.) When the track search ends, the found track is paused at its beginning.

Error Mode

If there is a problem with CD play, an error code will be displayed on the cassette player display. (Ex. ERROR-11)
If an error is displayed, refer to the table below to identify the problem. If the error is displayed even after corrective action is taken, contact your dealer or the nearest authorized PIONEER Service Station.

- E: Error number**
 - C: Cause**
 - T: Treatment**
- E: 11, 12, 14, 17, 30**
 - C: The disc is dirty.**
 - T: Clean the disc.**
 - E: 11, 12, 17, 30**
 - C: The disc is scratched.**
 - T: Replace the disc.**
 - E: 11, 12, 14, 17**
 - C: The disc is inserted with the label side up.**
 - T: Insert the disc with the label side down.**
 - E: 14**
 - C: An unrecorded CD-R is being used.**
 - T: Check the disc.**
 - E: .80**
 - C: An empty magazine is in the multi-play CD player.**
 - T: Insert discs into the magazine.**
 - E: 10, 11, 12, 14, 17, 30, 50, 60, 70, A0**
 - C: Electrical or mechanical fault.**
 - T: Turn the car ignition switch off and on again, or press the source switch on the cassette player to set CD playback again. If the error indication does not disappear, contact your nearest Pioneer service center or station.**

Specifications

Cassette player

General

Power source 14.4 V DC (10.8 — 15.6 V allowable)
 Grounding system Negative type
 Max. current consumption 8.5 A
 Dimensions (chassis) 178 (W) × 50 (H) × 150 (D) mm
 (front face) 188 (W) × 58 (H) × 19 (D) mm
 Weight 1.3 kg

Amplifier

Maximum power output 35 W × 4 (EIAJ)
 Continuous power output 22 W × 4 (DIN45324, +B = 14.4 V)
 Load impedance 4 Ω (4 — 8 Ω allowable)
 Preout output level/output impedance
 500 mV/1 kΩ
 Tone controls (bass) ±10 dB (100 Hz)
 (treble) ±10 dB (10 kHz)
 Loudness contour +10 dB (100 Hz), +7 dB (10 kHz)
 (Volume: -30 dB)

Tape player

Tape Compact cassette tape (C-30 — C-90)
 Tape speed 4.8 cm/sec.
 Fast forward/rewind time Approx. 100 sec. for C-60
 Wow & flutter 0.13 % (WRMS)
 Frequency response 40 — 14,000 Hz (±3 dB)
 Stereo separation 45 dB
 Signal-to-noise ratio 52 dB (IEC-A network)

FM tuner

Frequency range 87.5 — 108 MHz
 Usable sensitivity 11 dBf (1.0 μV/75 Ω, mono, S/N: 30 dB)
 50 dB quieting sensitivity 16 dBf (1.7 μV/75 Ω, mono)
 Signal-to-noise ratio 70 dB (IEC-A network)
 Distortion 0.3% (at 65 dBf, 1 kHz, stereo)
 Frequency response 30 — 15,000 Hz (±3 dB)
 Stereo separation 40 dB (at 65 dBf, 1 kHz)

MW tuner

Frequency range 531 — 1,602 kHz
 Usable sensitivity 18 μV (25 dB) (S/N: 20 dB)
 Selectivity 50 dB (±9 kHz)

LW tuner

Frequency range 153 — 281 kHz
 Usable sensitivity 30 μV (30 dB) (S/N: 20 dB)
 Selectivity 50 dB (±9 kHz)

Multi-play CD player

General

System Compact disc audio system
 Usable discs Compact Disc
 Signal format Sampling frequency: 44.1 kHz
 Number of quantization bits: 16; linear
 Power source 14.4 V DC (10.8 — 15.6 V allowable)
 Max. current consumption 1.0 A
 Dimensions 275 (W) × 69 (H) × 155 (D) mm
 Weight 2.4 kg

Audio

Frequency characteristics 5 — 20,000 Hz (±1 dB)
 Signal-to-noise ratio 92 dB (1 kHz) (IEC-A network)
 Distortion 0.006%
 Dynamic range 90 dB (1 kHz)
 Output level 1,000 mV (1 kHz, 0 dB)
 Number of channels 2 (stereo)

Note:

Specifications and design are subject to possible modification without prior notice due to improvements.