

■ **INTRODUCTION**

The CE6215 Series are a group of positive voltage regulators manufactured by CMOS technology with high ripple rejection, ultra-fast transient response and low dropout voltage, which provide large output currents even when the difference of the input-output voltage is small. Each of the CE6215 series consists of a high-precision voltage reference, an error correction circuit, and a current limited output driver. Thus the series are very suitable for the battery-powered equipments, wireless communication applications, industry equipments and so on.

■ **APPLICATIONS**

- Battery powered systems
- Portable instrumentations
- PC peripherals

■ **FEATURES**

- Guaranteed Output Current: 1.5A(Typ.)
- Low Quiescent Current: 50μA (Typ.)
- Output Voltage Range: 1.5V~5.0V
- Input Voltage Range: 2.5V~6.0V
- High Accuracy: ±2% (Typ.)
- Dropout Voltage:
600mV@1.5A (3.0V Typ.)
- Excellent Line Regulation: 0.02%/V
- High PSRR : 70dB @1KHz
- Built-in Current Limiter & Thermal Protection
- Short Circuit Current Fold-back

■ **BLOCK DIAGRAM**

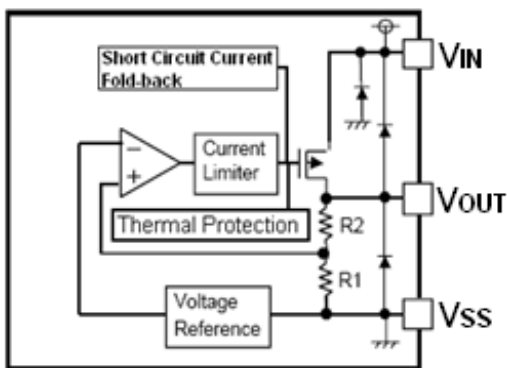

■ **ORDER INFORMATION**

CE6215①②③④

DESIGNATOR	SYMBOL	DESCRIPTION
①	A	Standard
②③	Integer	Output Voltage(1.5~5V) e.g:3.0V=②:3, ③:0
④	G	Package:SOT-223
	C	Package: TO-252
	D	Package: TO-263
	B	Package:TO-220

■ PIN CONFIGURATION

(Pin output sequence can be ordered by customer)

SOT-223 Top View

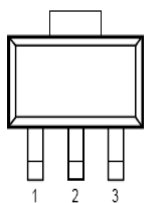

TO-252 Top View

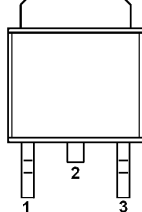

TO-263 Top View

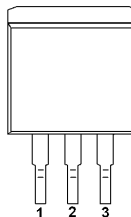

TO-220 Top View

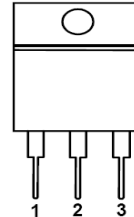

CE6215 (SOT-223, TO-252, TO-263, TO-220)

PIN NUMBER												PIN NAME	FUNCTION
SOT-223			TO-252			TO-263			TO-220				
G	GW	GL	C	CW	CL	D	DW	DL	B	BW	BL		
1	1	2	1	1	2	1	1	2	1	1	2	V_{SS}	Ground
2	3	1	2	3	1	2	3	1	2	3	1	V_{IN}	Power input
3	2	3	3	2	3	3	2	3	3	2	3	V_{OUT}	Output

■ ABSOLUTE MAXIMUM RATINGS

(Unless otherwise specified, $T_a=25^\circ\text{C}$)

PARAMETER	SYMBOL	RATINGS	UNITS
Input Voltage	V_{IN}	$V_{SS}-0.3\sim V_{SS}+7$	V
Output Current	I_{OUT}	2000	mA
Output Voltage	V_{OUT}	$V_{SS}-0.3\sim V_{IN}+0.3$	V
Power Dissipation	SOT-223	P_d	800
	TO-252	P_d	1477
	TO-263	P_d	2222
	TO-220	P_d	3000
Operating Temperature	T_{opr}	$-40\sim+85$	$^\circ\text{C}$
Storage Temperature	T_{stg}	$-40\sim+125$	$^\circ\text{C}$
Soldering Temperature & Time	T_{solder}	$260^\circ\text{C}, 10\text{s}$	

■ ELECTRICAL CHARACTERISTICS

CE6215 Series

(C_{IN}=C_{OUT}=4.7μF, Ta=25°C, unless otherwise specified)

PARAMETER	SYMBOL	CONDITIONS	MIN	TYP	MAX	UNITS
Output Voltage	V _{OUT(E)} (Note 2)	V _{IN} =V _{OUT} +1V I _{OUT} =100mA	V _{OUT} *0.98	V _{OUT} (Note 1)	V _{OUT} *1.02	V
Supply Current	I _Q	V _{IN} =V _{OUT} +1V		50	100	μA
Output Current	I _{OUT}	V _{IN} =V _{OUT} +2V (V _{OUT} <4V) V _{IN} =V _{OUT} +1V (V _{OUT} ≥4V)	1500			mA
Dropout Voltage (Note 3)	V _{diff}	I _{OUT} =1.5A	1.5V≤V _{OUT} ≤2.0V	1300		mV
			2.0V<V _{OUT} ≤2.8V	800		mV
			2.8V<V _{OUT}	600		mV
Load Regulation	ΔV _{OUT}	V _{IN} =V _{OUT} +2V (V _{OUT} <4V) V _{IN} =V _{OUT} +1V (V _{OUT} ≥4V) 1mA≤I _{OUT} ≤1.5A		30	100	mV
Line Regulation	$\frac{\Delta V_{OUT}}{\Delta V_{IN} * V_{OUT}}$	I _{OUT} =100mA V _{OUT} +1V≤V _{IN} ≤6V		0.02	0.2	%/V
Output Voltage Temperature Characteristics	$\frac{\Delta V_{OUT}}{\Delta T * V_{OUT}}$	I _{OUT} =100mA -40°C≤T≤+85°C		50		ppm/°C
Short Current	I _{Short}	V _{OUT} =V _{SS}		200		mA
Input Voltage	V _{IN}	—	2.5		6.0	V
Power Supply Rejection Rate	1KHz	PSRR	I _{OUT} =100mA	70		dB
	10KHz			50		
Thermal Shutdown Temperature	T _{SD}	—		150		°C
Thermal Shutdown Temperature Hysteresis	ΔT _{SD}	—		30		°C

NOTE:

1. V_{OUT}: Specified Output Voltage.
2. V_{OUT (E)} : Effective Output Voltage (I.e. The Output Voltage When V_{IN} = (V_{OUT} +1.0V) And Maintain A Certain I_{OUT} Value).
3. V_{diff}: The Difference Of Output Voltage And Input Voltage When Input Voltage Is Decreased Gradually Till Output Voltage Equals To 98% Of V_{OUT (E)}.

■ TYPICAL APPLICATION CIRCUIT

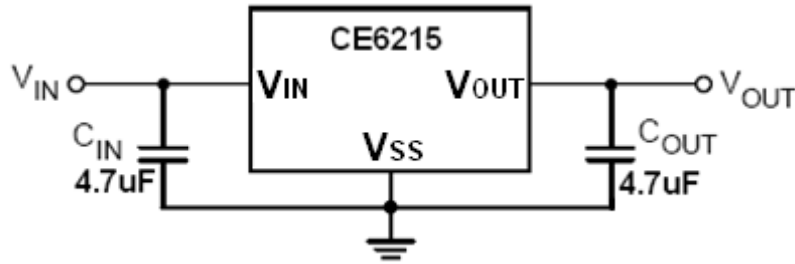

Input capacitor (C_{IN}): 4.7µF or more;

Output capacitor (C_{OUT}): 4.7µF or more;

Caution: A general series regulator may oscillate, depending on the external components selected. Check that no oscillation occurs with the application using the above capacitor.

■ TYPICAL PERFORMANCE CHARACTERISTICS

(1) Input Transient Response

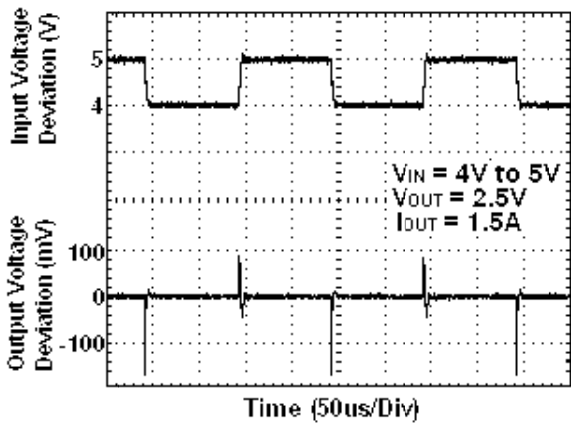

(2) Load Transient Response

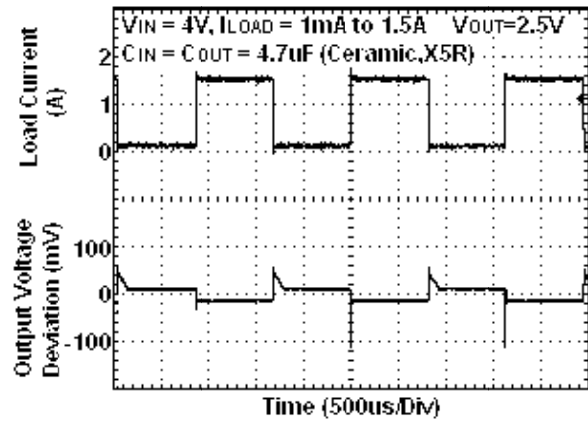

(3) Output Voltage vs. Temperature

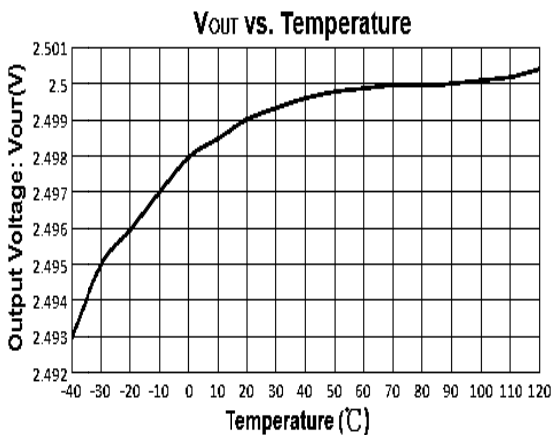

(4) Power Supply Rejection Ratio

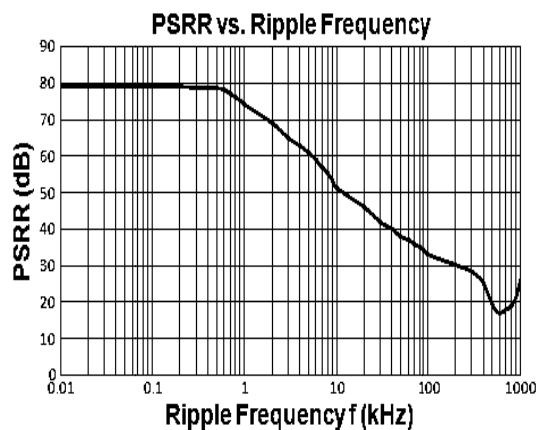

(5) Dropout Voltage vs. Output Current

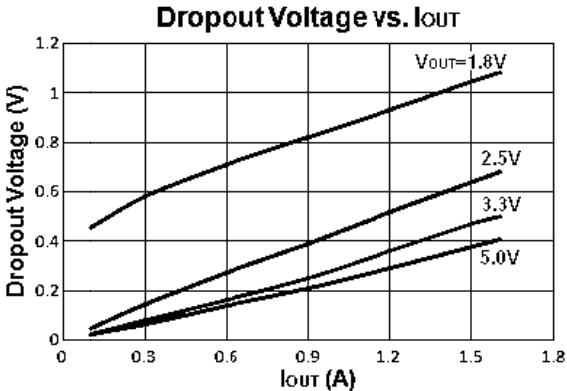

(6) Region of Stable C_{OUT} ESR vs. Load

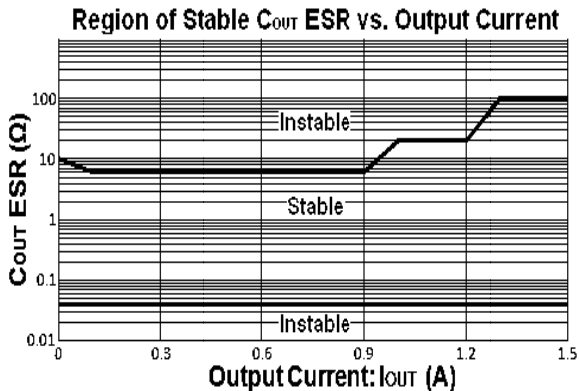

■ PACKAGING INFORMATION

● SOT-223 PACKAGE OUTLINE DIMENSIONS

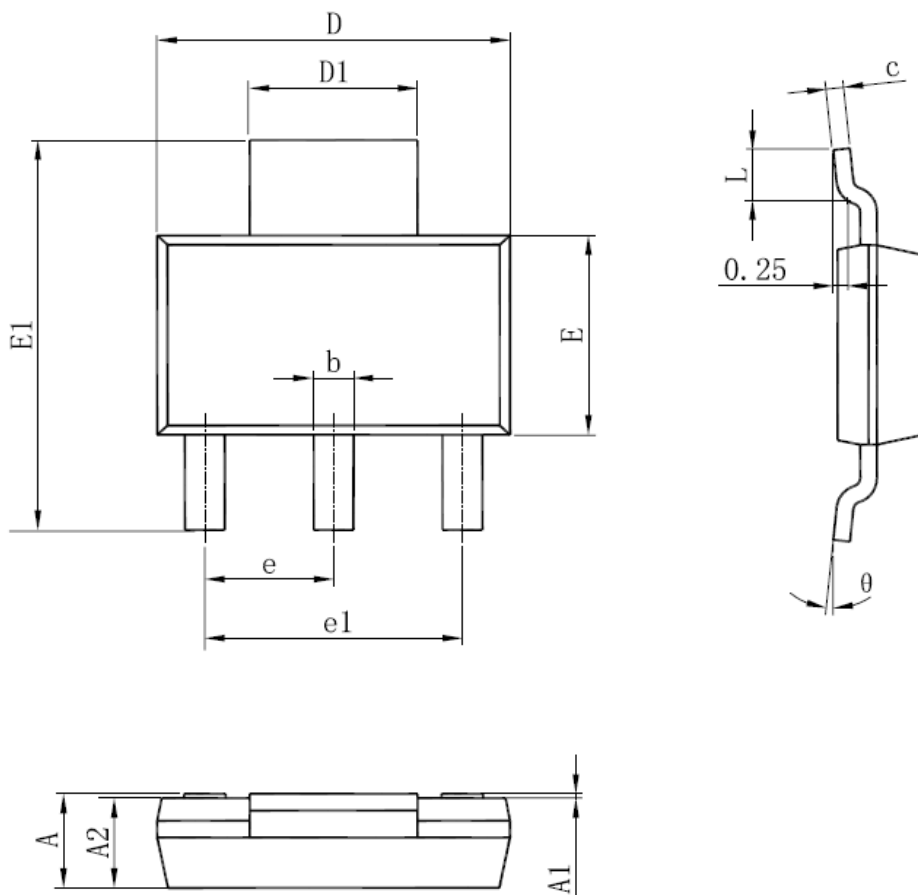

Symbol	Dimensions In Millimeters		Dimensions In Inches	
	Min	Max	Min	Max
A	1.520	1.800	0.060	0.071
A1	0.000	0.100	0.000	0.004
A2	1.500	1.700	0.059	0.067
b	0.660	0.820	0.026	0.032
c	0.250	0.350	0.010	0.014
D	6.200	6.400	0.244	0.252
D1	2.900	3.100	0.114	0.122
E	3.300	3.700	0.130	0.146
E1	6.830	7.070	0.269	0.278
e	2.300(BSC)		0.091(BSC)	
e1	4.500	4.700	0.177	0.185
L	0.900	1.150	0.035	0.045
theta	0°	10°	0°	10°

• TO-252 PACKAGE OUTLINE DIMENSIONS

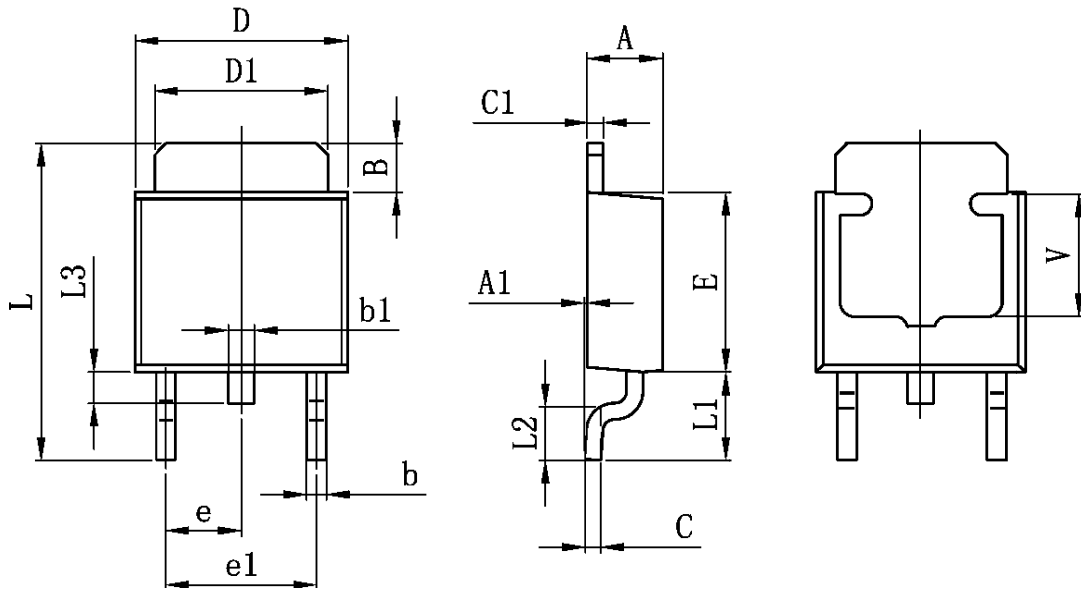

Symbol	Dimensions In Millimeters		Dimensions In Inches	
	Min.	Max.	Min.	Max.
A	2.200	2.400	0.087	0.094
A1	0.000	0.127	0.000	0.005
B	1.350	1.650	0.053	0.065
b	0.500	0.700	0.020	0.028
b1	0.700	0.900	0.028	0.035
c	0.430	0.580	0.017	0.023
c1	0.430	0.580	0.017	0.023
D	6.350	6.650	0.250	0.262
D1	5.200	5.400	0.205	0.213
E	5.400	5.700	0.213	0.224
e	2.300 TYP.		0.091 TYP.	
e1	4.500	4.700	0.177	0.185
L	9.500	9.900	0.374	0.390
L1	2.550	2.900	0.100	0.114
L2	1.400	1.780	0.055	0.070
L3	0.600	0.900	0.024	0.035
V	3.800 REF.		0.150 REF.	

• TO-263 PACKAGE OUTLINE DIMENSIONS

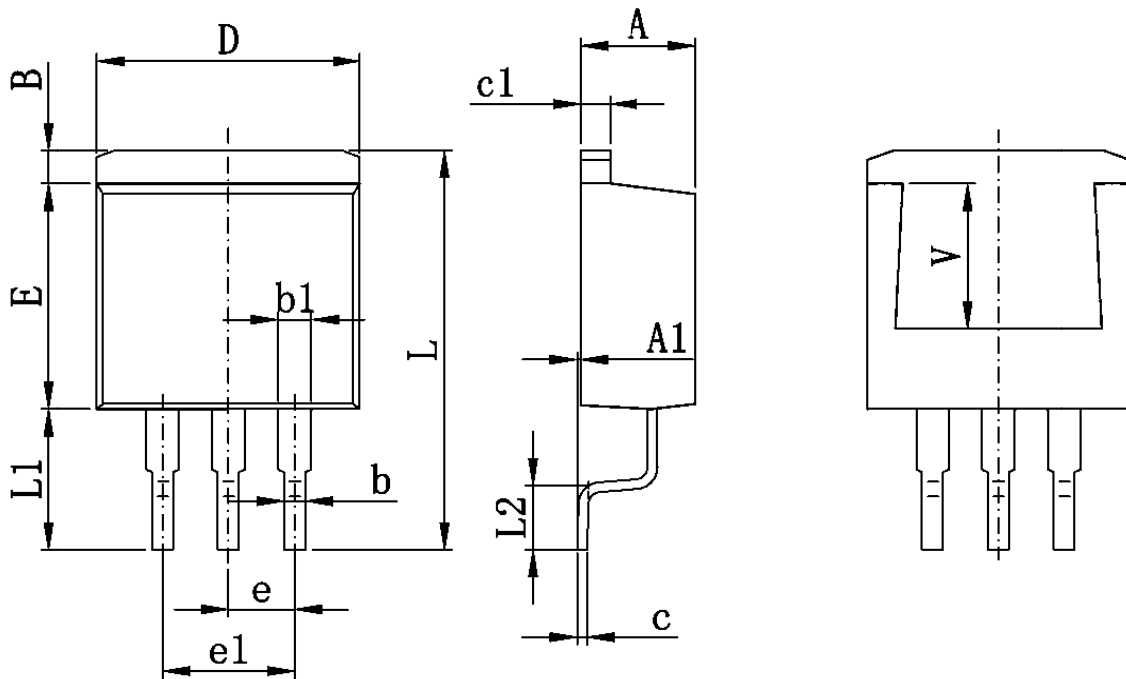

Symbol	Dimensions In Millimeters		Dimensions In Inches	
	Min	Max	Min	Max
A	4.470	4.670	0.176	0.184
A1	0.000	0.150	0.000	0.006
B	1.170	1.370	0.046	0.054
b	0.710	0.910	0.028	0.036
b1	1.170	1.370	0.046	0.054
c	0.310	0.530	0.012	0.021
c1	1.170	1.370	0.046	0.054
D	10.010	10.310	0.394	0.406
E	8.500	8.900	0.335	0.350
e	2.540 TYP		0.100 TYP	
e1	4.980	5.180	0.196	0.204
L	15.050	15.450	0.593	0.608
L1	5.080	5.480	0.200	0.216
L2	2.340	2.740	0.092	0.108
V	5.600 REF		0.220 REF	

• TO-220 PACKAGE OUTLINE DIMENSIONS

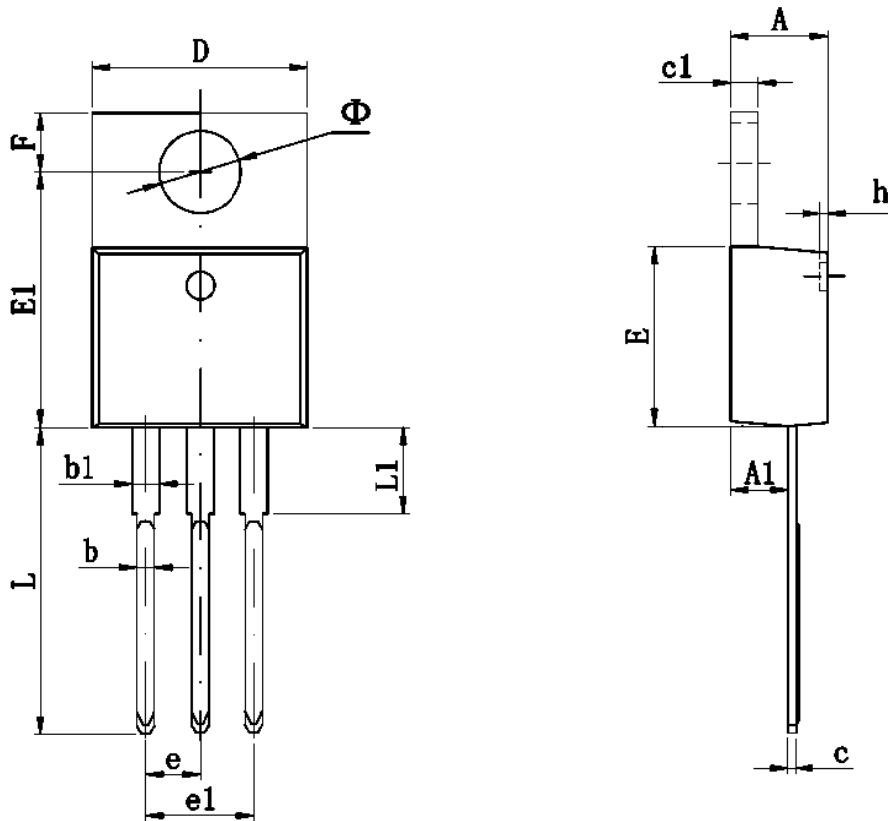

Symbol	Dimensions In Millimeters		Dimensions In Inches	
	Min	Max	Min	Max
A	4.470	4.670	0.176	0.184
A1	2.520	2.820	0.099	0.111
b	0.710	0.910	0.028	0.036
b1	1.170	1.370	0.046	0.054
c	0.310	0.530	0.012	0.021
c1	1.170	1.370	0.046	0.054
D	10.010	10.310	0.394	0.406
E	8.500	8.900	0.335	0.350
E1	12.060	12.460	0.475	0.491
e	2.540 TYP		0.100 TYP	
e1	4.980	5.180	0.196	0.204
F	2.590	2.890	0.102	0.114
h	0.000	0.300	0.000	0.012
L	13.400	13.800	0.528	0.543
L1	3.560	3.960	0.140	0.156
Φ	3.735	3.935	0.147	0.155

© Nanjing Chipower Electronics Inc.

Chipower cannot assume responsibility for use of any circuitry other than circuitry entirely embodied in a Chipower product. No circuit patent license, copyrights or other intellectual property rights are implied. Chipower reserves the right to make changes to their products or specifications without notice. Customers are advised to obtain the latest version of relevant information to verify, before placing orders, that information being relied on is current and complete.