

**Ultralow-Noise, High PSRR, Fast RF
Low-Dropout CMOS Voltage Regulator**

CE6300 Series

■ INTRODUCTION

The CE6300 series are a group of positive voltage regulators manufactured by CMOS technologies with high ripple rejection, ultra low noise, low power consumption and low dropout voltage, which can prolong battery life in portable electronics. The CE6300 series work with low-ESR ceramic capacitors, reducing the amount of board space necessary for power applications. The CE6300 series consume less than 0.1µA in shutdown mode and have fast turn-on time less than 50µs. The series are very suitable for the battery-powered equipments, such as RF applications and other systems requiring a quiet voltage source.

■ APPLICATIONS

- RF: VCOs, Receivers, ADCs
- Cellular and Cordless Telephones
- Handheld Organizers

■ FEATURES

- 500mA RF Low-Dropout Regulator With Enable
- Ultralow-Noise: 40µV_{RMS}(10Hz~100kHz)
- High PSRR: 70dB@1kHz
- Fast Start-Up Time (20µs)
- Excellent Load/Line Transient Response
- Low Dropout Voltage: 110mV@100mA
- Stable With a 1µF Ceramic Capacitor
- Available in Adjustable Voltage Version (0.6V to 5.5V)
- Built-in Current Limiter, Short-Circuit Protection

■ BLOCK DIAGRAM

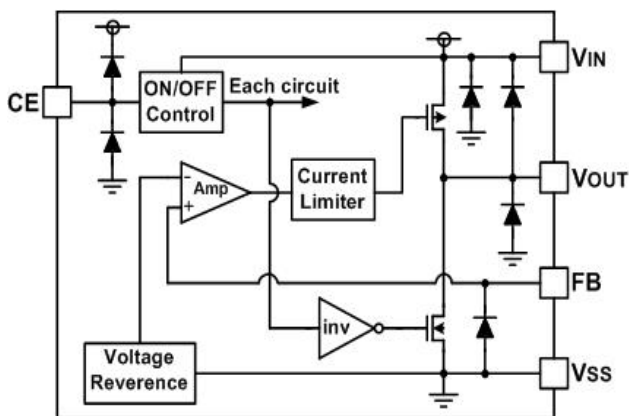

■ ORDER INFORMATION

CE6300①②

DESIGNATOR	SYMBOL	DESCRIPTION
①	B	High Active, pull-down resistor built in, with C _{OUT} discharge resistor
	C	High Active, No pull-down resistor built in, with C _{OUT} discharge resistor
②	U	Package:SC70-5
	M	Package:SOT-23-5
	E	Package:SOT-23-6

■ PIN CONFIGURATION

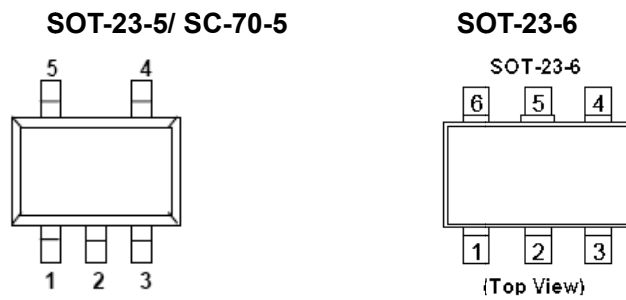

SOT-23-5/ SC-70-5

PIN NUMBER		PIN NAME	FUNCTION
M	U		
1	1	V _{IN}	Power input Pin
2	2	V _{SS}	Ground
3	3	CE	Chip Enable Pin
4	4	FB	Feedback Pin: Used to Set Output Voltage
5	5	V _{OUT}	Output Pin

SOT-23-6

PIN NUMBER		PIN NAME	FUNCTION
E	FC6		
1	6	V _{IN}	Power input Pin
2	3	V _{SS}	Ground
3	4	CE	Chip Enable Pin
5	2	FB	Feedback Pin: Used to Set Output Voltage
6	1	V _{OUT}	Output Pin
4	5	NC	Not Connection
-	7		Thermal Pad

■ TYPICAL APPLICATION

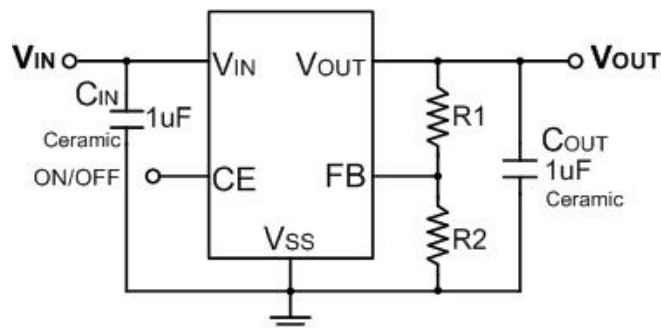

Fig.1 Typical Application Circuit

■ ABSOLUTE MAXIMUM RATINGS

 (Unless otherwise specified, $T_A=25^\circ\text{C}$)

PARAMETER		SYMBOL	RATINGS	UNITS
Input Voltage		V_{IN}	$V_{SS} - 0.3 \sim V_{SS} + 8$	V
Output Current		I_{OUT}	750	mA
Output Voltage		V_{OUT}	$V_{SS} - 0.3 \sim V_{IN} + 0.3$	V
Power Dissipation	SOT-23-5	P_d	400	mW
	SOT-23-6	P_d	400	mW
Operating Temperature		T_{opr}	$-40 \sim +85$	$^\circ\text{C}$
Storage Temperature		T_{stg}	$-40 \sim +125$	$^\circ\text{C}$
Soldering Temperature & Time		T_{solder}	$260^\circ\text{C}, 10\text{s}$	

■ ELECTRICAL CHARACTERISTICS
CE6300 Series

 ($V_{IN}=V_{OUT}+1\text{V}$, $C_{IN}=C_{OUT}=1\mu\text{F}$, $T_A=25^\circ\text{C}$, unless otherwise specified)

PARAMETER	SYMBOL	CONDITIONS	MIN.	TYP.	MAX.	UNITS
Input Voltage	V_{IN}	—	1.8 ⁽¹⁾		7.0	V
Output Current	I_{OUT}	$V_{OUT} \geq 1.8\text{V}$	500			mA
Supply Current	I_{SS}	$I_{OUT}=0\text{mA}$		45	80	μA
Standby Current	I_{STBY}	$V_{CE}=0\text{V}$			0.1	μA
CE "High" Voltage	V_{CEH}		1.2		V_{IN}	V
CE "Low" Voltage	V_{CEL}				0.3	V
CE pin current		$V_{CE}=0\text{V}$	-1		1	μA
FB Voltage	V_{FB}	$I_{OUT}=1\text{mA}$	0.588	0.600	0.612	V
FB pin current		$V_{FB}=1.8\text{V}$			1	μA
Output voltage range			0.6		$5.5 - V_{DO}$	V
Line Regulation	$\frac{\Delta V_{OUT}}{V_{OUT} \times \Delta V_{IN}}$	$I_{OUT} = 10\text{mA}$ $V_{OUT} + 1\text{V} \leq V_{IN} \leq 7\text{V}$		0.01	0.2	%/V
Load Regulation	ΔV_{OUT}	$V_{IN} = V_{OUT} + 1\text{V}$, $1\text{mA} \leq I_{OUT} \leq 100\text{mA}$		1		mV
Dropout Voltage ⁽²⁾	V_{dif}	$I_{OUT} = 100\text{mA}$ $V_{OUT} \geq 3.0\text{V}$		110		mV
Output Voltage Temperature Characteristics	$\frac{\Delta V_{OUT}}{\Delta T \times V_{OUT}}$	$I_{OUT} = 10\text{mA}$ $-40 \leq T \leq +85$		50		ppm
Current Limit	I_{LIM}		600	750		mA
Short Current	I_{SHORT}	$V_{OUT} = V_{SS}$		20		mA
Power Supply Ripple Rejection	$V_{OUT} = 1.2\text{V}$	PSRR	$f=100\text{Hz}, I_{OUT}=50\text{mA}$		80	dB
			$f=1\text{kHz}, I_{OUT}=50\text{mA}$		70	
			$f=10\text{kHz}, I_{OUT}=50\text{mA}$		50	
Output noise voltage		BW=10Hz to 100kHz, $I_{OUT}=10\text{mA}$		40		μV_{RMS}
Time, start-up		$I_{OUT}=0\text{mA}, C_{OUT}=1\mu\text{F}$		20		μs

NOTE:

- (1) Minimum V_{IN} is 1.8V or $V_{OUT} + V_{DO}$, whichever is greater.
- (2) V_{dif} : The difference of output voltage and input voltage when input voltage is decreased gradually till output voltage equals to 98% of V_{OUT} (E).

■ DROPOUT VOLTAGE CHART

Setting Output Voltage	Dropout Voltage (mV) Typ.			
$V_{OUT}(V)$	$I_{OUT}=100mA$	$I_{OUT}=200mA$	$I_{OUT}=300mA$	$I_{OUT}=500mA$
1.2	380mV	640mV	880mV	
1.5	250mV	480mV	680mV	
1.8	190mV	380mV	570mV	950mV
2.1	155mV	310mV	470mV	820mV
2.5	130mV	260mV	400mV	700mV
2.8	120mV	240mV	360mV	640mV
3.0	110mV	230mV	350mV	610mV
3.3	105mV	210mV	320mV	570mV
3.6	100mV	200mV	310mV	540mV
4.0	95mV	185mV	290mV	500mV
4.5	90mV	180mV	280mV	470mV
5.0	85mV	170mV	260mV	440mV

■ TYPICAL PERFORMANCE CHARACTERISTICS

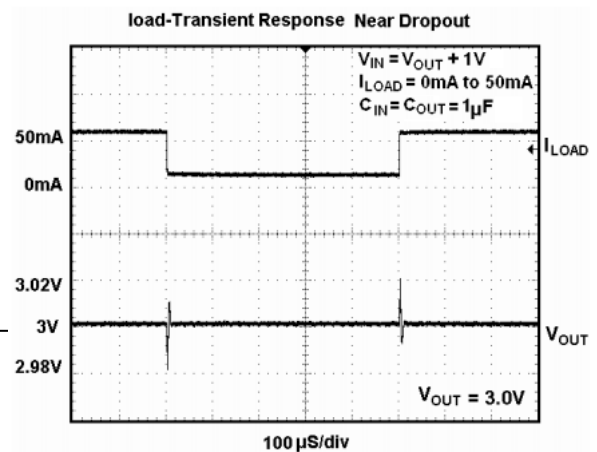
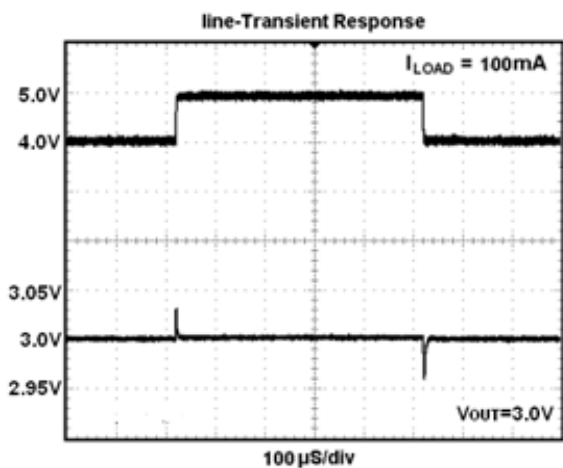
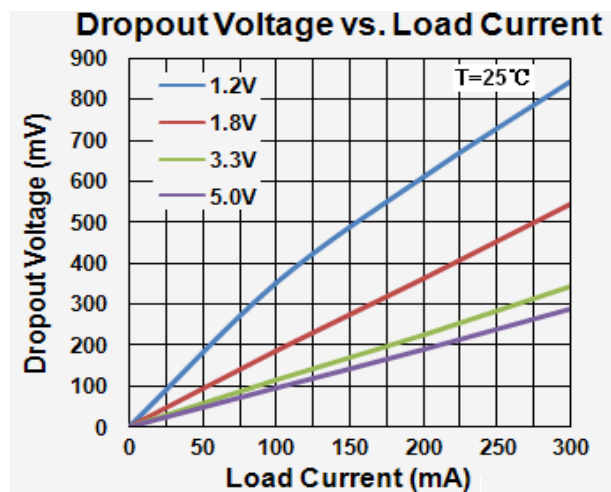
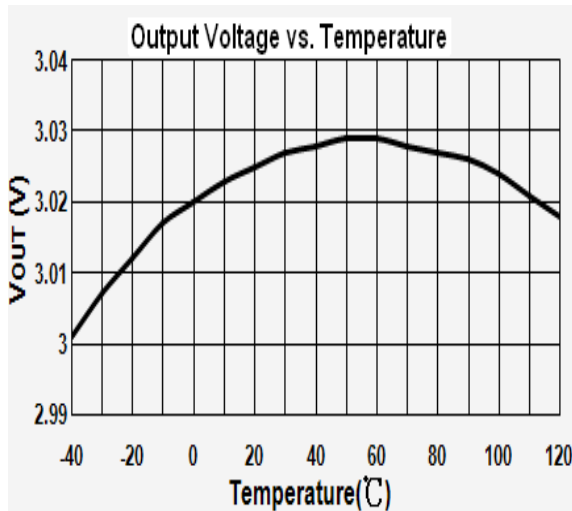

■ TYPICAL PERFORMANCE CHARACTERISTICS(Continued)

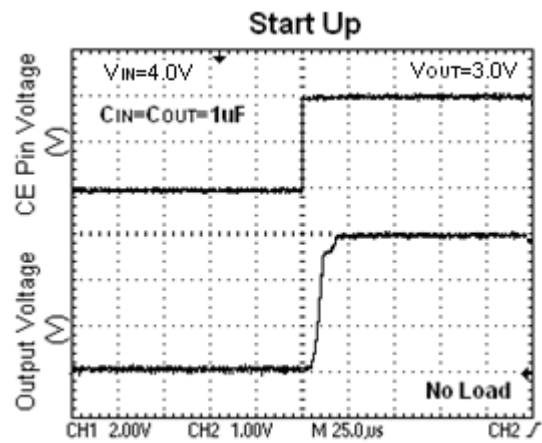
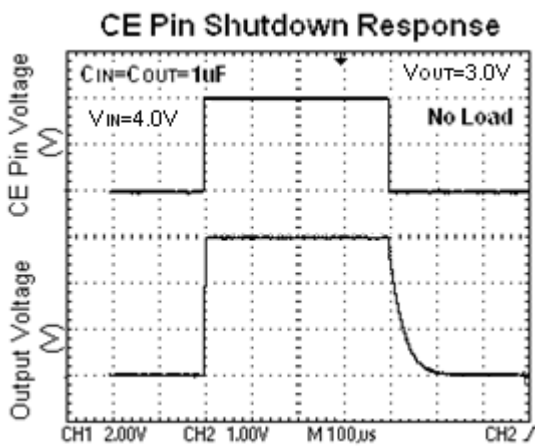
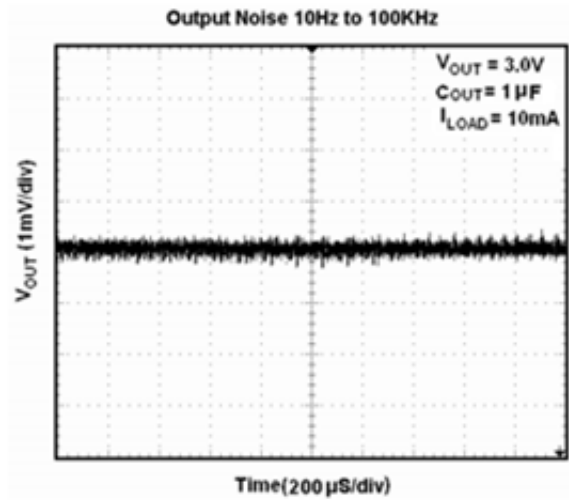
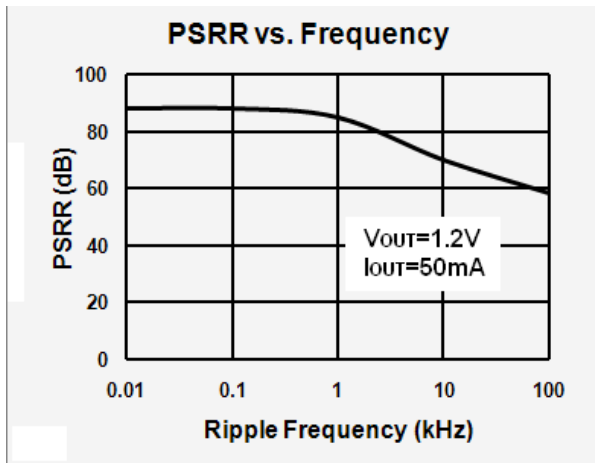

■ APPLICATION INFORMATION

Setting The Output Voltage

Figure 1 shows the typical application circuit with CE6300. The external resistor sets the output voltage according to the following equation:

$$V_{OUT} = 0.6V \times \left(1 + \frac{R1}{R2}\right)$$

Table 1. Resistor select for output voltage setting

V_{OUT}	R1	R2
1.2V	30.1K	30.1K
1.5V	45.3K	30.1K
1.8V	60.4K	30.1K
2.5V	95.3K	30.1k
2.8V	110K	30.1k
3.0V	120K	30.1K
3.3V	137K	30.1K
5.0V	221K	30.1k

■ PACKAGING INFORMATION

● SOT-23-5 PACKAGE OUTLINE DIMENSIONS

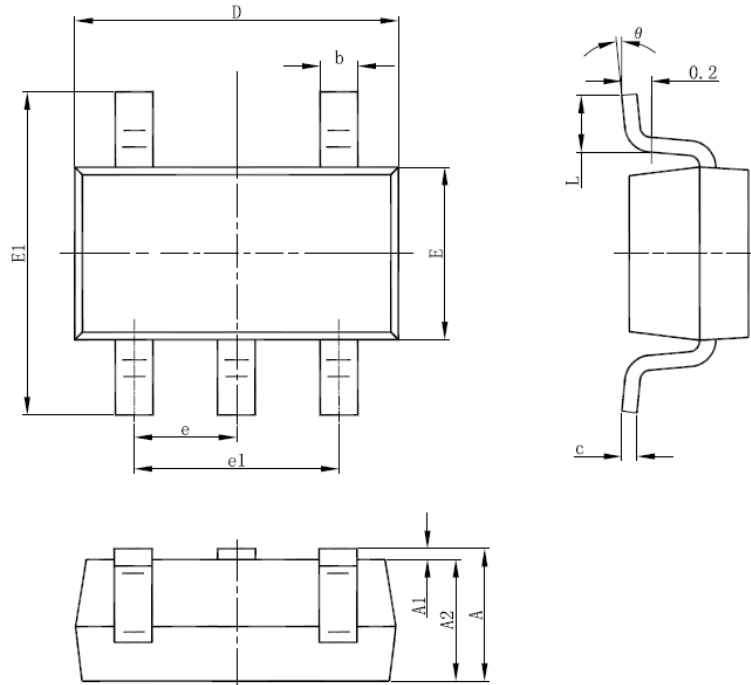

Symbol	Dimensions In Millimeters		Dimensions In Inches	
	Min	Max	Min	Max
A	1.050	1.250	0.041	0.049
A1	0.000	0.100	0.000	0.004
A2	1.050	1.150	0.041	0.045
b	0.300	0.500	0.012	0.020
c	0.100	0.200	0.004	0.008
D	2.820	3.020	0.111	0.119
E	1.500	1.700	0.059	0.067
E1	2.650	2.950	0.104	0.116
e	0.950(BSC)		0.037(BSC)	
e1	1.800	2.000	0.071	0.079
L	0.300	0.600	0.012	0.024
θ	0°	8°	0°	8°

• SOT-23 -6 PACKAGE OUTLINE DIMENSIONS

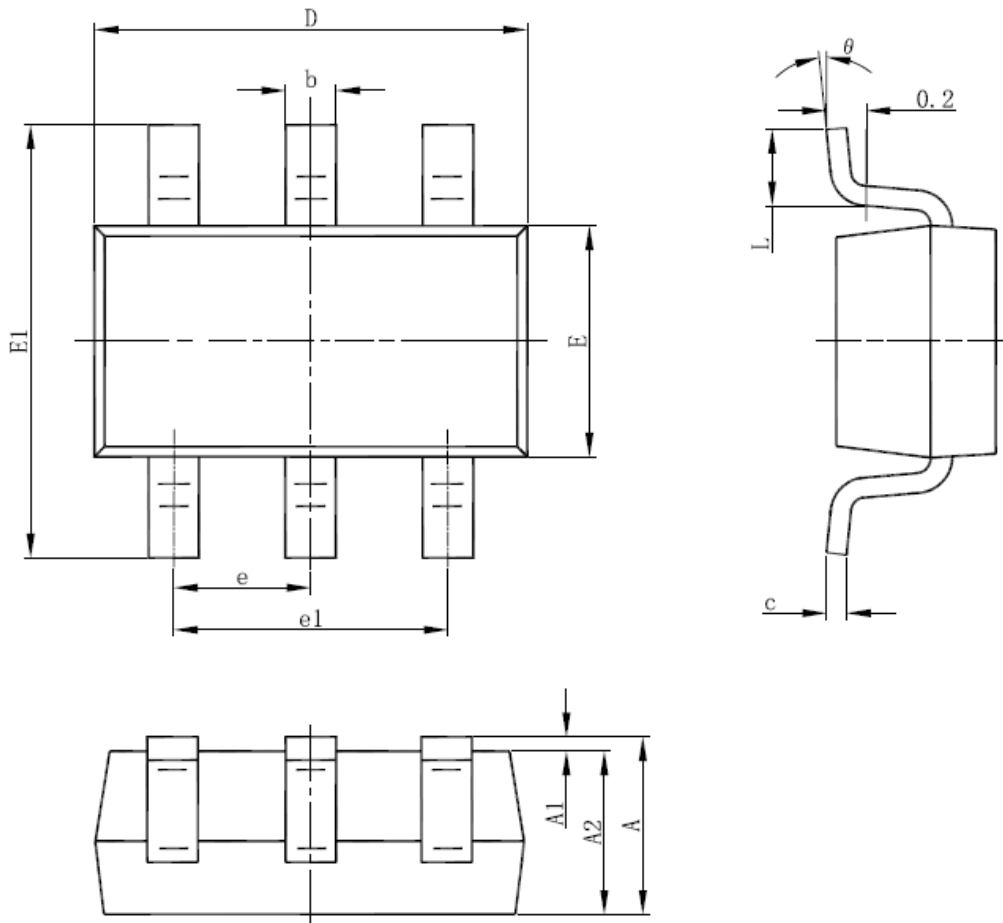

Symbol	Dimensions In Millimeters		Dimensions In Inches	
	Min	Max	Min	Max
A	1.050	1.250	0.041	0.049
A1	0.000	0.100	0.000	0.004
A2	1.050	1.150	0.041	0.045
b	0.300	0.500	0.012	0.020
c	0.100	0.200	0.004	0.008
D	2.820	3.020	0.111	0.119
E	1.500	1.700	0.059	0.067
E1	2.650	2.950	0.104	0.116
e	0.950(BSC)		0.037(BSC)	
e1	1.800	2.000	0.071	0.079
L	0.300	0.600	0.012	0.024
theta	0°	8°	0°	8°

●SC-70-5 PACKAGE OUTLINE DIMENSIONS

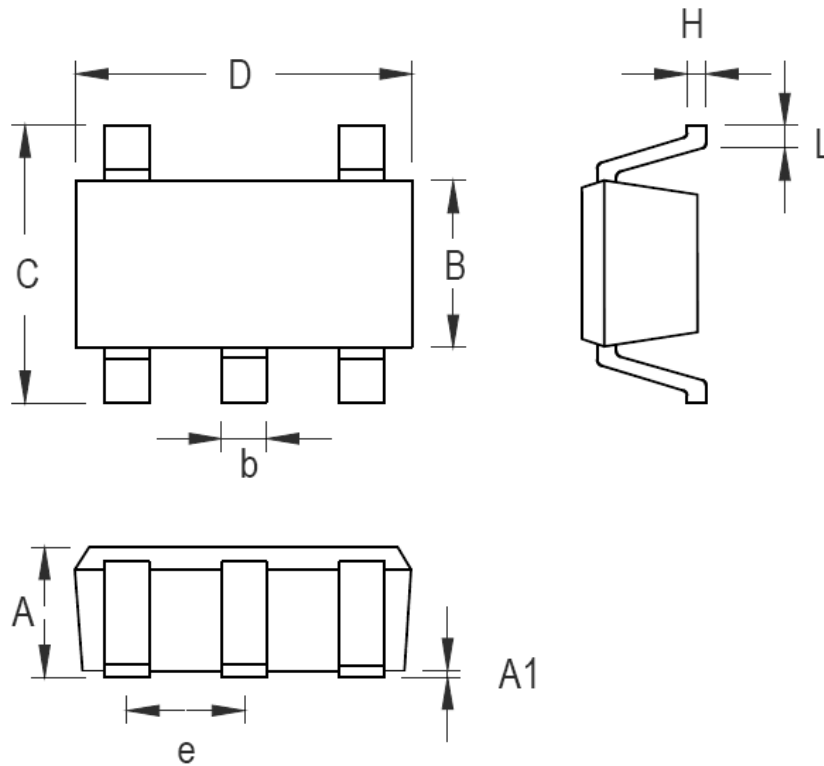

Symbol	Dimensions In Millimeters		Dimension In Inches	
	Min.	Max.	Min.	Max.
A	0.800	1.100	0.031	0.044
A1	0.000	0.100	0.000	0.004
B	1.100	1.400	0.044	0.055
b	0.150	0.300	0.006	0.012
C	1.950	2.200	0.077	0.087
D	1.800	2.150	0.071	0.085
e	0.650BSC		0.026BSC	
H	0.080	0.260	0.003	0.010
L	0.260	0.460	0.010	0.018

© Nanjing Chipower Electronics Inc.

Chipower cannot assume responsibility for use of any circuitry other than circuitry entirely embodied in a Chipower product. No circuit patent license, copyrights or other intellectual property rights are implied. Chipower reserves the right to make changes to their products or specifications without notice. Customers are advised to obtain the latest version of relevant information to verify, before placing orders, that information being relied on is current and complete.