

■ **INTRODUCTION**

The CE6301 series are a group of positive voltage regulators manufactured by CMOS technologies with low power consumption and low dropout voltage, which provide large output currents even when the difference of the input-output voltage is small. The CE6301 series can deliver 300mA output current and allow an input voltage as high as 18V. The series are very suitable for the battery-powered equipments, such as RF applications and other systems requiring a quiet voltage source.

■ **FEATURES**

- Low Quiescent Current: 2 μ A
- Operating Voltage Range: 2.5V~18V
- Output Current: 300mA
- Low Dropout Voltage:
160mV@100mA($V_{OUT}=3.3V$)
- Output Voltage: 1.2~ 5.0V
- High Accuracy: $\pm 2\%$ (Typ.)
- High Power Supply Rejection Ratio:
70dB@1kHz
- Low Output Noise:
27x V_{OUT} μ V_{RMS} (10Hz~100kHz)
- Excellent Line and Load Transient Response
- Built-in Current Limiter, Short-Circuit Protection
- Over-Temperature Protection
- Stable with Ceramic or Tantalum Capacitor

■ **APPLICATIONS**

- Cordless Phones
- Radio control systems
- Laptop, Palmtops and PDAs
- Single-lens reflex DSC
- PC peripherals with memory
- Wireless Communication Equipments
- Portable Audio Video Equipments
- Car Navigation Systems
- LAN Cards
- Ultra Low Power Microcontrollers

■ **BLOCK DIAGRAM**

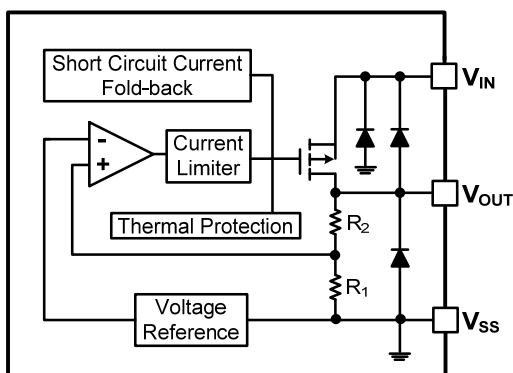

■ **ORDER INFORMATION**

CE6301①②③④

DESIGNATOR	SYMBOL	DESCRIPTION
①	A	Standard
②③	Integer	Output Voltage e.g. 1.8V=②:1, ③:8
④	M/ MC/ MY	Package:SOT-23-3
	MF/MR	Package:SOT-23-5
	P/PT/PL	Package:SOT-89-3
	T/TA/TB	Package:TO-92

■ PIN CONFIGURATION

SOT-23-3

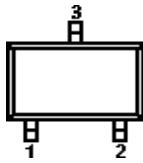

SOT-23-5

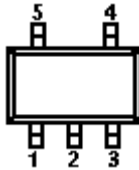

SOT-89-3

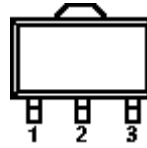

TO-92



PIN NUMBER									PIN NAME	FUNCTION
SOT-23-3			SOT-89-3			TO-92				
M	MC	MY	P	PT	PL	T	TA	TB		
1	3	3	1	2	2	1	2	2	V _{SS}	Ground
2	2	1	3	1	3	3	3	1	V _{OUT}	Output
3	1	2	2	3	1	2	1	3	V _{IN}	Power input

SOT-23-5

PIN NUMBER		SYMBOL	FUNCTION
MF	MR		
1	2	V _{IN}	Power Input
2	1	V _{SS}	Ground
3/4	4/5	NC	No Connection
5	3	V _{OUT}	Output

■ ABSOLUTE MAXIMUM RATINGS⁽¹⁾

(Unless otherwise specified, $T_A=25^{\circ}\text{C}$)

PARAMETER	SYMBOL	RATINGS	UNITS	
Input Voltage ⁽²⁾	V_{IN}	-0.3~24	V	
Output Voltage ⁽²⁾	V_{OUT}	-0.3~10	V	
Output Current	I_{OUT}	600	mA	
Power Dissipation	P_D	SOT-23	0.4	W
		SOT-89	0.6	W
		TO-92	0.6	W
Operating free air temperature range	T_A	-40~85	$^{\circ}\text{C}$	
Operating Junction Temperature Range ⁽³⁾	T_j	-40~125	$^{\circ}\text{C}$	
Storage Temperature	T_{stg}	-40~125	$^{\circ}\text{C}$	
Lead Temperature(Soldering, 10 sec)	T_{solder}	260	$^{\circ}\text{C}$	
ESD rating ⁽⁴⁾	Human Body Model -(HBM)	8	kV	
	Machine Model- (MM)	400	V	

(1) Stresses beyond those listed under *absolute maximum ratings* may cause permanent damage to the device. These are stress ratings only, and functional operation of the device at these or any other conditions beyond those indicated under *recommended operating conditions* is not implied. Exposure to absolute-maximum-rated conditions for extended periods may affect device reliability.

(2) All voltages are with respect to network ground terminal.

(3) This IC includes over temperature protection that is intended to protect the device during momentary overload. Junction temperature will exceed 125°C when over temperature protection is active. Continuous operation above the specified maximum operating junction temperature may impair device reliability.

(4) ESD testing is performed according to the respective JESD22 JEDEC standard.

The human body model is a 100 pF capacitor discharged through a 1.5k Ω resistor into each pin. The machine model is a 200pF capacitor discharged directly into each pin.

■ RECOMMENDED OPERATING CONDITIONS

PARAMETER	MIN.	NOM.	MAX.	UNITS
Supply voltage at V_{IN}	2.5		18	V
Operating junction temperature range, T_j	0		125	$^{\circ}\text{C}$
Operating free air temperature range, T_A	0		85	$^{\circ}\text{C}$

■ ELECTRICAL CHARACTERISTICS

CE6301 Series ($V_{IN}=V_{OUT}+1V$, $C_{IN}=C_{OUT}=1\mu F$, $T_A=25^\circ C$, unless otherwise specified)

PARAMETER	SYMBOL	CONDITIONS	MIN.	TYP. ⁽⁶⁾	MAX.	UNITS
Input Voltage	V_{IN}		2.5	—	18	V
Output Voltage Range	V_{OUT}		1.2	—	5	V
DC Output Accuracy		$I_{OUT}=1mA$	-2	—	2	%
Dropout Voltage	$V_{dif}^{(7)}$	$I_{OUT}=100mA, V_{OUT}=3.3V$	—	160	—	mV
Supply Current	I_{SS}	$I_{OUT}=0A$	—	2	5	μA
Line Regulation	$\frac{\Delta V_{OUT}}{V_{OUT} \times \Delta V_{IN}}$	$I_{OUT}=10mA$ $V_{OUT}+1V \leq V_{IN} \leq 18V$	—	0.01	0.3	%/V
Load Regulation	ΔV_{OUT}	$V_{IN}=V_{OUT}+1V$, $1mA \leq I_{OUT} \leq 100mA$	—	10	—	mV
Temperature Coefficient	$\frac{\Delta V_{OUT}}{V_{OUT} \times \Delta T_A}$	$I_{OUT}=10mA$, $-40^\circ C < T_A < 125^\circ C$	—	50	—	ppm
Output Current Limit	I_{LIM}	$V_{OUT}=0.5 \times V_{OUT(Normal)}$, $V_{IN}=5V$	350	450	550	mA
Short Current	I_{SHORT}	$V_{OUT}=V_{SS}$	—	40	—	mA
Power Supply Rejection Ratio	PSRR	$I_{OUT}=50mA$	100Hz	—	80	dB
			1kHz	—	70	
			10kHz	—	60	
			100kHz	—	40	
Output Noise Voltage	V_{ON}	BW=10Hz to 100kHz	—	$27 \times V_{OUT}$	—	μV_{RMS}
Thermal Shutdown Temperature	T_{SD}	—	—	150	—	$^\circ C$
Thermal Shutdown Hysteresis	ΔT_{SD}	—	—	20	—	$^\circ C$

(6) Typical numbers are at 25°C and represent the most likely norm.

(7) V_{dif} : The Difference Of Output Voltage And Input Voltage When Input Voltage Is Decreased Gradually Till Output Voltage Equals To 98% Of V_{OUT} (E).

■ TYPICAL APPLICATION CIRCUIT

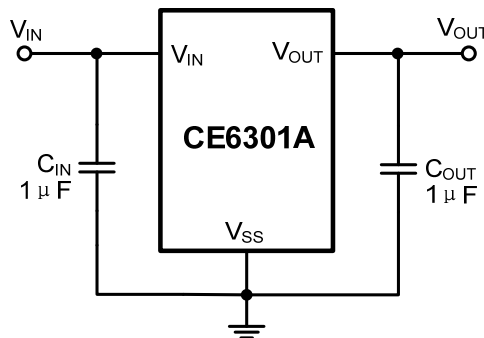

■ APPLICATION INFORMATION

Selection of Input/ Output Capacitors

In general, all the capacitors need to be low leakage. Any leakage the capacitors have will reduce efficiency, increase the quiescent current.

A recent trend in the design of portable devices has been to use ceramic capacitors to filter DC/DC converter inputs. Ceramic capacitors are often chosen because of their small size, low equivalent series resistance (ESR) and high RMS current capability. Also, recently, designers have been looking to ceramic capacitors due to shortages of tantalum capacitors.

Unfortunately, using ceramic capacitors for input filtering can cause problems. Applying a voltage step to a ceramic capacitor causes a large current surge that stores energy in the inductances of the power leads. A large voltage spike is created when the stored energy is transferred from these inductances into the ceramic capacitor. These voltage spikes can easily be twice the amplitude of the input voltage step. (See “Ceramic Input Capacitors Can Cause Overvoltage Transients”——Linear Technology application note 88, March 2001)

Many types of capacitors can be used for input bypassing, however, caution must be exercised when using multilayer ceramic capacitors (MLCC). Because of the self-resonant and high Q characteristics of some types of ceramic capacitors, high voltage transients can be generated under some start-up conditions, such as connecting the LDO input to a live power source. Adding a 3Ω resistor in series with an X5R ceramic capacitor will minimize start-up voltage transients.

The LDO also requires an output capacitor for loop stability. Connect a 1μF tantalum capacitor from OUT to GND close to the pins. For improved transient response, this output capacitor may be ceramic.

■ TYPICAL PERFORMANCE CHARACTERISTICS

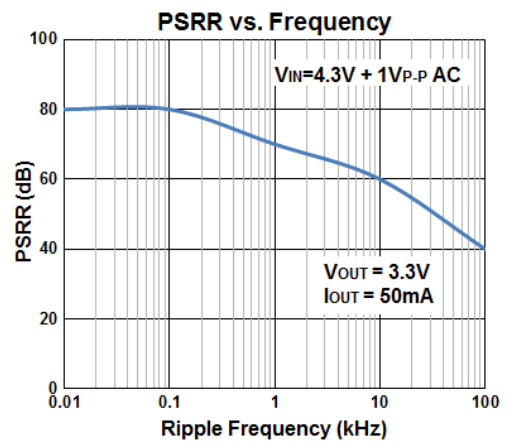
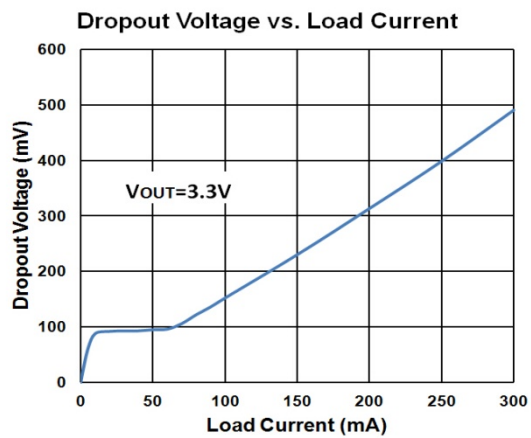
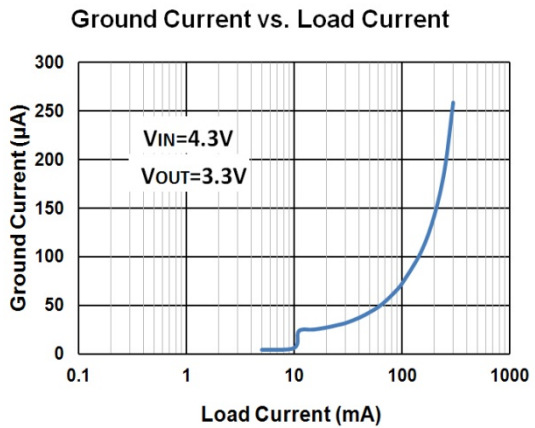
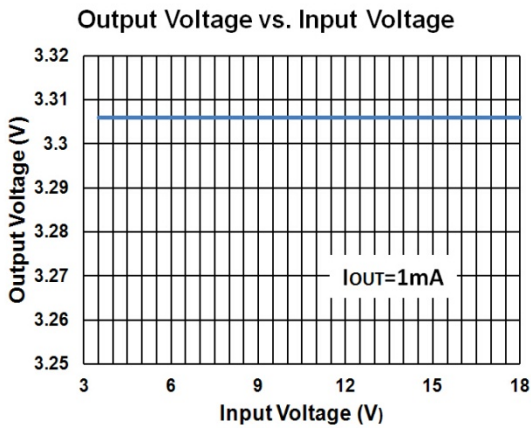
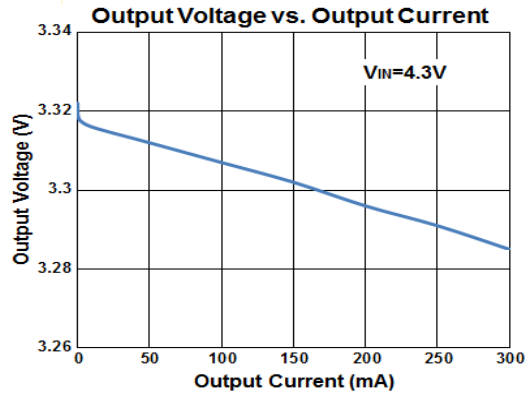
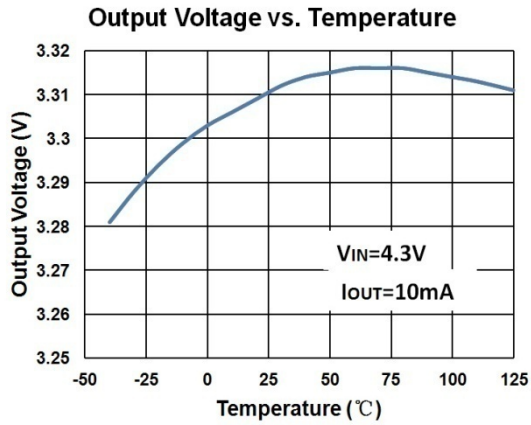

■ TYPICAL PERFORMANCE CHARACTERISTICS(continued)

Load Transient Response

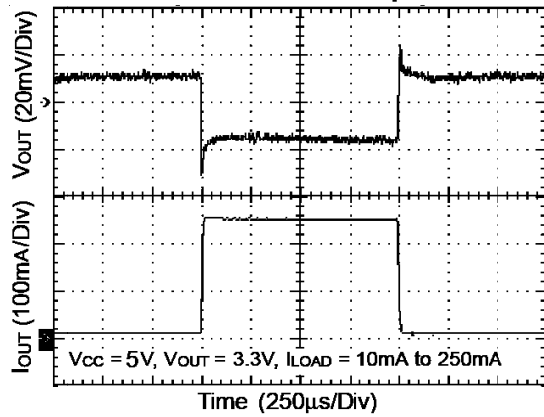

Line Transient Response

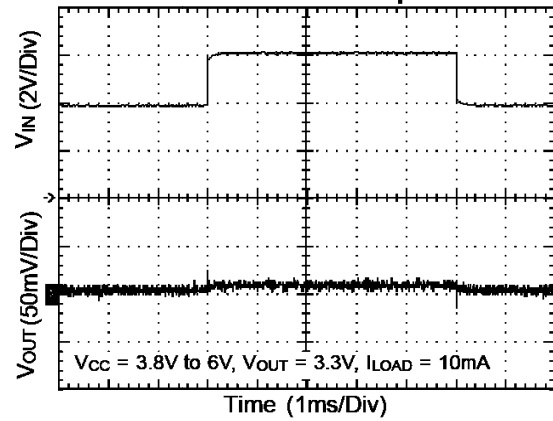

Power Up Response

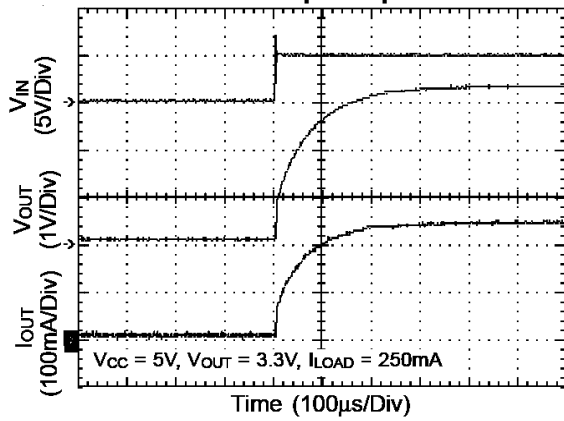

Output Noise 10Hz to 100KHz

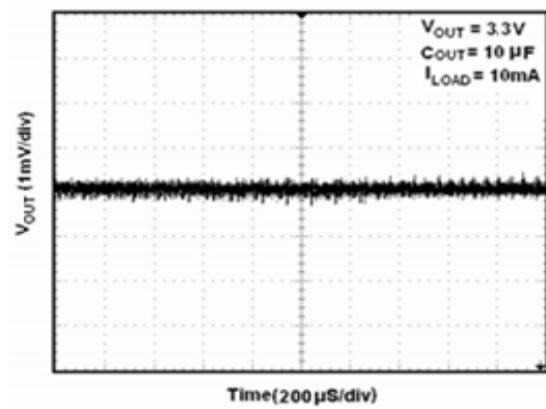

■ PACKAGING INFORMATION

● SOT-23-3 PACKAGE OUTLINE DIMENSIONS

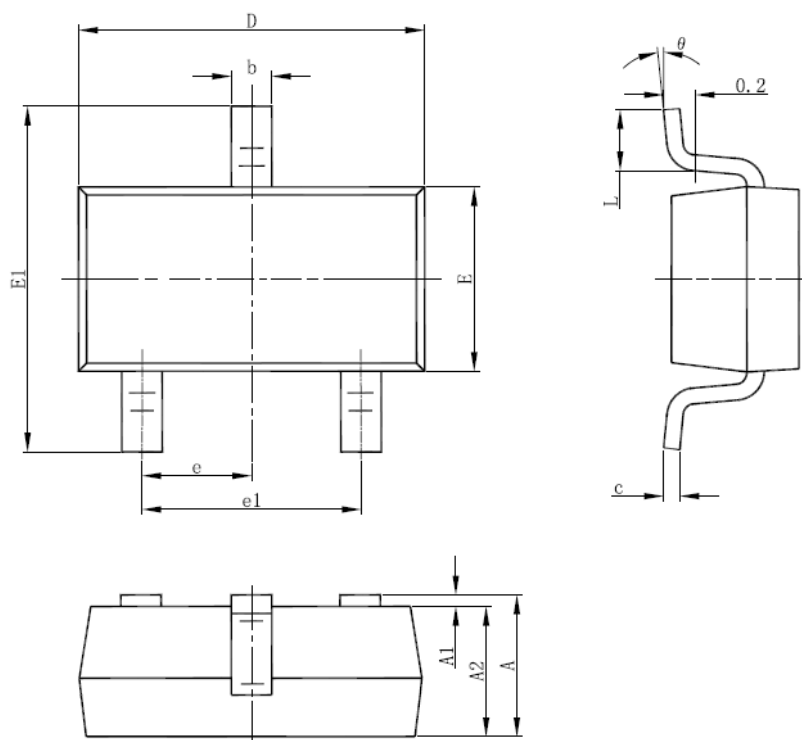

Symbol	Dimensions In Millimeters		Dimensions In Inches	
	Min.	Max.	Min.	Max.
A	1.050	1.250	0.041	0.049
A1	0.000	0.100	0.000	0.004
A2	1.050	1.150	0.041	0.045
b	0.300	0.500	0.012	0.020
c	0.100	0.200	0.004	0.008
D	2.820	3.020	0.111	0.119
E	1.500	1.700	0.059	0.067
E1	2.650	2.950	0.104	0.116
e	0.950(BSC)		0.037(BSC)	
e1	1.800	2.000	0.071	0.079
L	0.300	0.600	0.012	0.024
θ	0°	8°	0°	8°

● SOT-23-5 PACKAGE OUTLINE DIMENSIONS

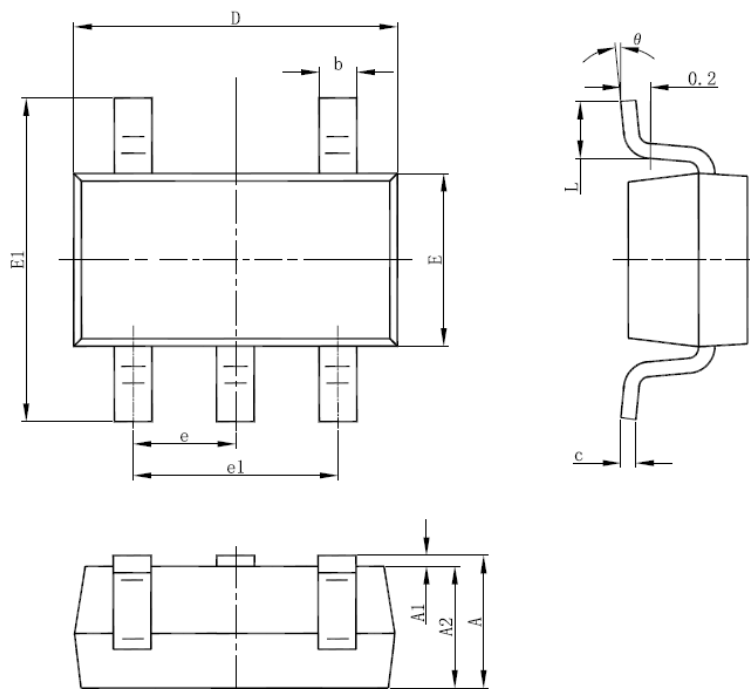

Symbol	Dimensions In Millimeters		Dimensions In Inches	
	Min.	Max.	Min.	Max.
A	1.050	1.250	0.041	0.049
A1	0.000	0.100	0.000	0.004
A2	1.050	1.150	0.041	0.045
b	0.300	0.500	0.012	0.020
c	0.100	0.200	0.004	0.008
D	2.820	3.020	0.111	0.119
E	1.500	1.700	0.059	0.067
E1	2.650	2.950	0.104	0.116
e	0.950(BSC)		0.037(BSC)	
e1	1.800	2.000	0.071	0.079
L	0.300	0.600	0.012	0.024
θ	0°	8°	0°	8°

● SOT-89-3 PACKAGE OUTLINE DIMENSIONS

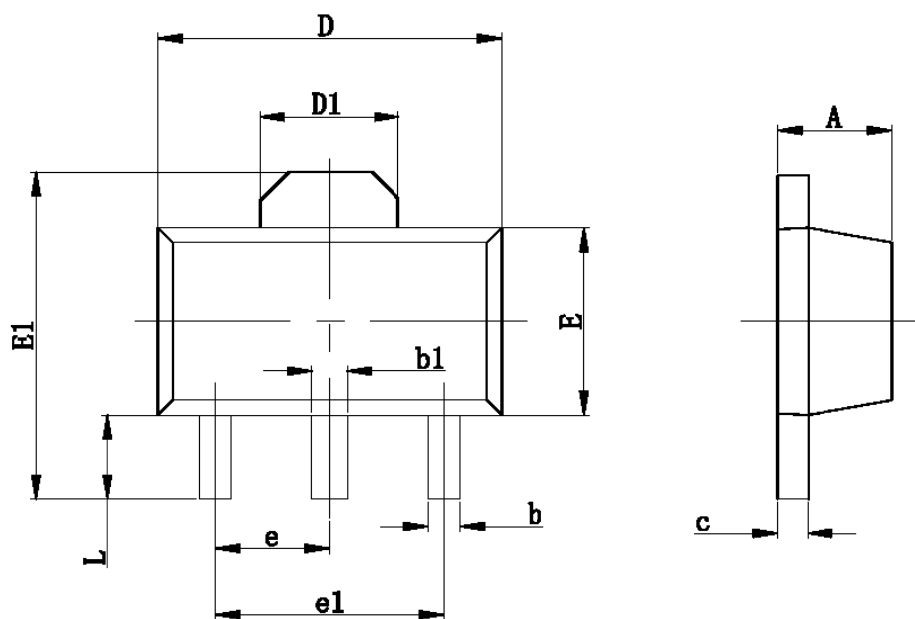

Symbol	Dimensions In Millimeters		Dimensions In Inches	
	Min.	Max.	Min.	Max.
A	1.400	1.600	0.055	0.063
b	0.320	0.520	0.013	0.197
b1	0.400	0.580	0.016	0.023
c	0.350	0.440	0.014	0.017
D	4.400	4.600	0.173	0.181
D1	1.550 REF		0.061 REF	
E	2.300	2.600	0.091	0.102
E1	3.940	4.250	0.155	0.167
e	1.500 TYP		0.060 TYP	
e1	3.000 TYP		0.118 TYP	
L	0.900	1.200	0.035	0.047

● TO-92 PACKAGE OUTLINE DIMENSIONS

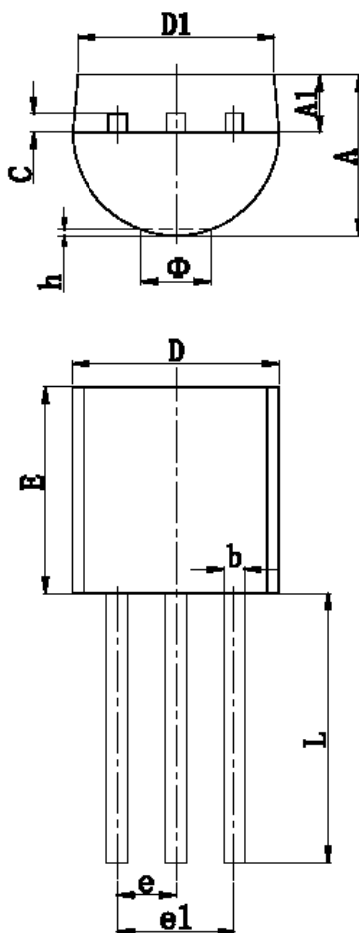

Symbol	Dimensions In Millimeters		Dimensions In Inches	
	Min.	Max.	Min.	Max.
A	3.300	3.700	0.130	0.146
A1	1.100	1.400	0.043	0.055
b	0.380	0.550	0.015	0.022
c	0.360	0.510	0.014	0.020
D	4.400	4.700	0.173	0.185
D1	3.430		0.135	
E	4.300	1.400	0.169	0.185
e	1.270 TYP		0.050 TYP	
e1	2.440	2.640	0.096	0.104
L	14.100	14.500	0.555	0.571
Φ		1.600		0.063
h	0.000	0.380	0.000	0.015

© Nanjing Chipower Electronics Inc.

Chipower cannot assume responsibility for use of any circuitry other than circuitry entirely embodied in a Chipower product. No circuit patent license, copyrights or other intellectual property rights are implied. Chipower reserves the right to make changes to their products or specifications without notice. Customers are advised to obtain the latest version of relevant information to verify, before placing orders, that information being relied on is current and complete.