



# CEP20A03/CEB20A03

## N-Channel Enhancement Mode Field Effect Transistor

PRELIMINARY

### FEATURES

- 30V, 197A,  $R_{DS(ON)} = 2\text{ m}\Omega$  @  $V_{GS} = 10\text{V}$ .  
 $R_{DS(ON)} = 3\text{ m}\Omega$  @  $V_{GS} = 4.5\text{V}$ .
- Super high dense cell design for extremely low  $R_{DS(ON)}$ .
- High power and current handling capability.
- Lead-free plating ; RoHS compliant.
- TO-220 & TO-263 package.

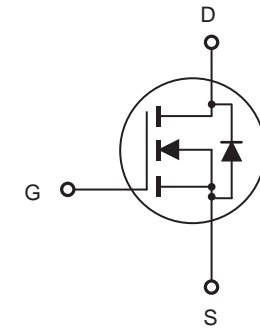

### ABSOLUTE MAXIMUM RATINGS $T_C = 25^\circ\text{C}$ unless otherwise noted

Parameter	Symbol	Limit	Units
Drain-Source Voltage	$V_{DS}$	30	V
Gate-Source Voltage	$V_{GS}$	$\pm 20$	V
Drain Current-Continuous @ $T_C = 25^\circ\text{C}$ @ $T_C = 100^\circ\text{C}$	$I_D$	197	A
		124	A
Drain Current-Pulsed <sup>a</sup>	$I_{DM}$	788	A
Maximum Power Dissipation @ $T_C = 25^\circ\text{C}$ - Derate above $25^\circ\text{C}$	$P_D$	139	W
		1.1	W/ $^\circ\text{C}$
Single Pulsed Avalanche Energy <sup>d</sup>	$E_{AS}$	800	mJ
Single Pulsed Avalanche Current <sup>d</sup>	$I_{AS}$	40	A
Operating and Store Temperature Range	$T_J, T_{stg}$	-55 to 150	$^\circ\text{C}$

### Thermal Characteristics

Parameter	Symbol	Limit	Units
Thermal Resistance, Junction-to-Case	$R_{\theta JC}$	0.9	$^\circ\text{C/W}$
Thermal Resistance, Junction-to-Ambient	$R_{\theta JA}$	62.5	$^\circ\text{C/W}$

This is preliminary information on a new product in development now .  
 Details are subject to change without notice .

Rev 1. 2012.Jun  
<http://www.cetsemi.com>



# CEP20A03/CEB20A03

## Electrical Characteristics $T_C = 25^\circ\text{C}$ unless otherwise noted

Parameter	Symbol	Test Condition	Min	Typ	Max	Units
<b>Off Characteristics</b>						
Drain-Source Breakdown Voltage	$BV_{DSS}$	$V_{GS} = 0V, I_D = 250\mu A$	30			V
Zero Gate Voltage Drain Current	$I_{DSS}$	$V_{DS} = 30V, V_{GS} = 0V$			1	$\mu A$
Gate Body Leakage Current, Forward	$I_{GSSF}$	$V_{GS} = 20V, V_{DS} = 0V$			100	nA
Gate Body Leakage Current, Reverse	$I_{GSSR}$	$V_{GS} = -20V, V_{DS} = 0V$			-100	nA
<b>On Characteristics<sup>b</sup></b>						
Gate Threshold Voltage	$V_{GS(th)}$	$V_{GS} = V_{DS}, I_D = 250\mu A$	1		3	V
Static Drain-Source On-Resistance	$R_{DS(on)}$	$V_{GS} = 10V, I_D = 30A$		1.6	2	$m\Omega$
		$V_{GS} = 4.5V, I_D = 30A$		2	3	$m\Omega$
Gate input resistance	$R_g$	$f=1\text{MHz}, \text{open Drain}$		2		$\Omega$
<b>Dynamic Characteristics<sup>c</sup></b>						
Input Capacitance	$C_{iss}$	$V_{DS} = 15V, V_{GS} = 0V, f = 1.0 \text{ MHz}$		7950		pF
Output Capacitance	$C_{oss}$			1055		pF
Reverse Transfer Capacitance	$C_{rss}$			740		pF
<b>Switching Characteristics<sup>c</sup></b>						
Turn-On Delay Time	$t_{d(on)}$	$V_{DD} = 15V, I_D = 15A, V_{GS} = 4.5V, R_{GEN} = 1\Omega$		41	82	ns
Turn-On Rise Time	$t_r$			32	64	ns
Turn-Off Delay Time	$t_{d(off)}$			92	184	ns
Turn-Off Fall Time	$t_f$			30	60	ns
Total Gate Charge	$Q_g$	$V_{DS} = 15V, I_D = 50A, V_{GS} = 4.5V$		96	125	nC
Gate-Source Charge	$Q_{gs}$			24		nC
Gate-Drain Charge	$Q_{gd}$			39		nC
<b>Drain-Source Diode Characteristics and Maximun Ratings</b>						
Drain-Source Diode Forward Current	$I_S$				115	A
Drain-Source Diode Forward Voltage <sup>b</sup>	$V_{SD}$	$V_{GS} = 0V, I_S = 30A$			1.2	V
<b>Notes :</b> a.Repetitive Rating : Pulse width limited by maximum junction temperature b.Pulse Test : Pulse Width < 300 $\mu s$ , Duty Cycle < 2%. c.Guaranteed by design, not subject to production testing. d.L = 1mH, $I_{AS} = 40A, V_{DD} = 24V, R_G = 25\Omega, \text{Starting } T_J = 25 \text{ C}$						



# CEP20A03/CEB20A03

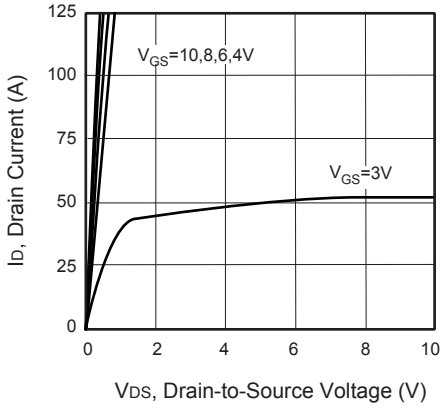

**Figure 1. Output Characteristics**

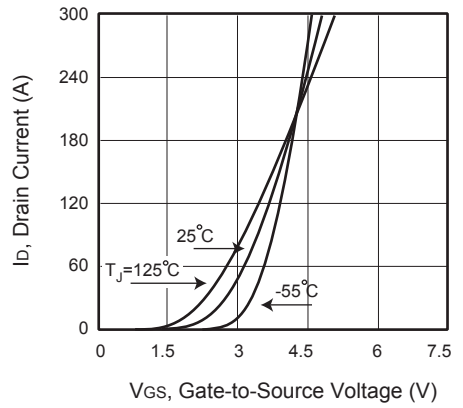

**Figure 2. Transfer Characteristics**

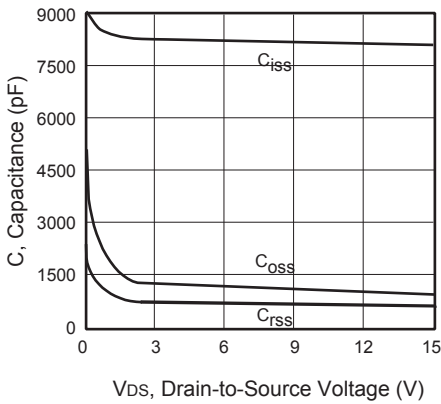

**Figure 3. Capacitance**

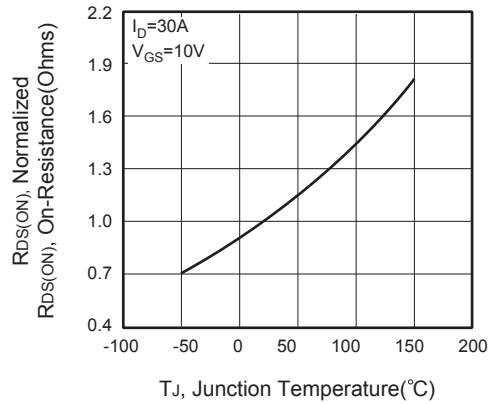

**Figure 4. On-Resistance Variation with Temperature**

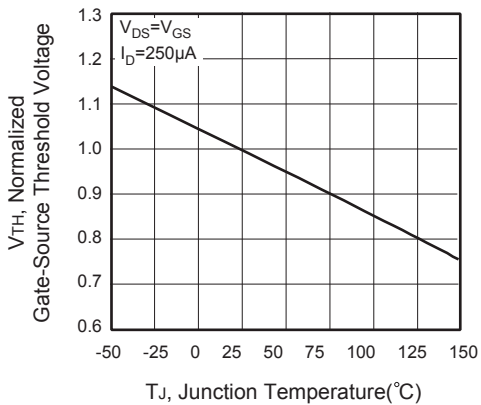

**Figure 5. Gate Threshold Variation with Temperature**

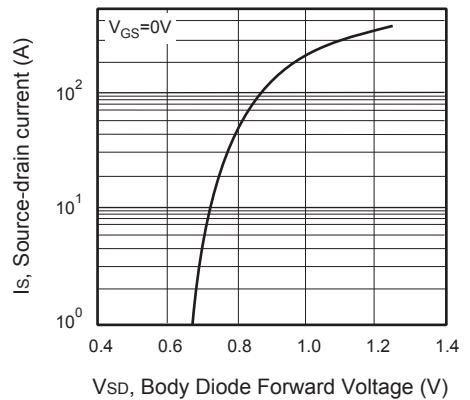

**Figure 6. Body Diode Forward Voltage Variation with Source Current**



# CEP20A03/CEB20A03

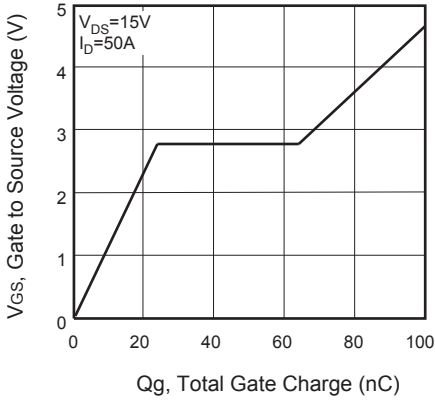

Figure 7. Gate Charge

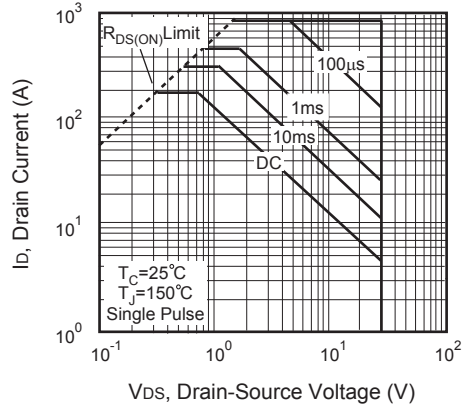

Figure 8. Maximum Safe Operating Area

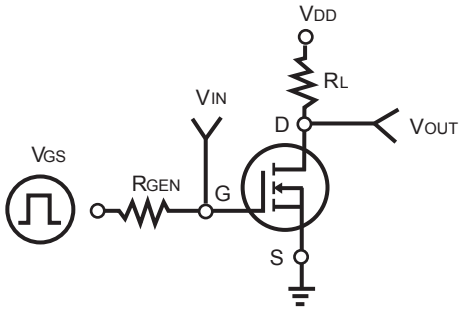

Figure 9. Switching Test Circuit



Figure 10. Switching Waveforms

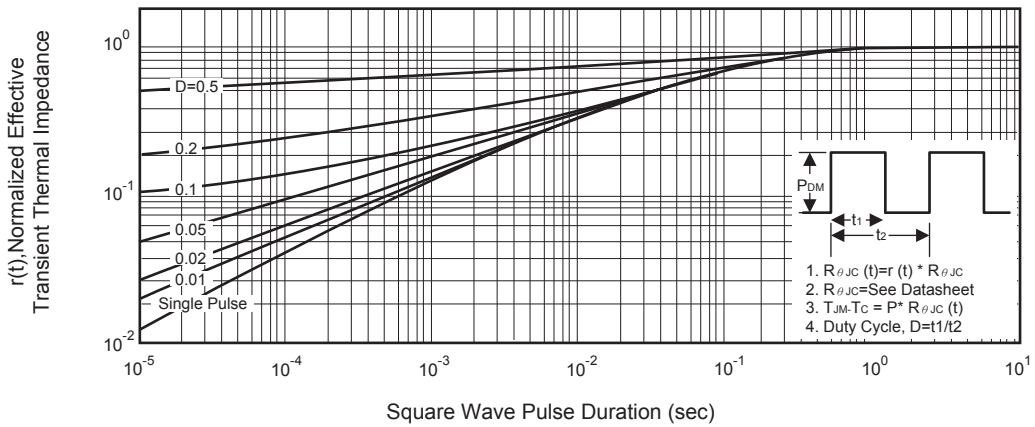

Figure 11. Normalized Thermal Transient Impedance Curve