

Service Manual

Simplified

Notebook Computer

Model No. **CF-19FHGAXxM**

TOUGHBOOK

This is the Service Manual for
the following areas.
M ...for U.S.A. and Canada

Model No. CF-19FHGAX 1 M

1: Operation System

A: Microsoft® Windows® XP Professional

J: Microsoft® Windows® VISTA Business

 **WARNING**

This service information is designed for experienced repair technicians only and is not designed for use by the general public. It does not contain warnings or cautions to advise non-technical individuals of potential dangers in attempting to service a product. Products powered by electricity should be serviced or repaired only by experienced professional technicians. Any attempt to service or repair the product or products dealt with in this service information by anyone else could result in serious injury or death.

Panasonic[®]

© 2007 Matsushita Electric Industrial Co., Ltd. All rights reserved.
Unauthorized copying and distribution is a violation of law.

WARNING

For U.K.

This apparatus must be earthed for your safety.

To ensure safe operation the three-pin plug must be inserted only into a standard three-pin power point which is effectively earthed through the normal household wiring.

Extension cords used with the equipment must be three-core and be correctly wired to provide connection to earth. Wrongly wired extension cords are a major cause of fatalities.

The fact that the equipment operates satisfactorily does not imply that the power point is earthed and that the installation is completely safe.

For your safety, if you have any doubt about the effective earthing of the power point, consult a qualified electrician.

FOR YOUR SAFETY PLEASE READ THE FOLLOWING TEXT CAREFULLY

This appliance is supplied with a moulded three pin mains plug for your safety and convenience.

A 3 amp fuse is fitted in this plug.

Should the fuse need to be replaced please ensure that the replacement fuse has a rating of 3 amps and that it is approved by ASTA or BSI to BS 1362.

Check for the ASTA mark  or the BSI mark  on the body of the fuse.

If the plug contains a removable fuse cover you must ensure that it is refitted when the fuse is replaced.

If you lose the fuse cover the plug must not be used until a replacement cover is obtained.

A replacement fuse cover can be purchased from your local Panasonic Dealer.

IF THE FITTED MOULDED PLUG IS UNSUITABLE FOR THE SOCKET OUTLET IN YOUR HOME THEN THE FUSE SHOULD BE REMOVED AND THE PLUG CUT OFF AND DISPOSED OF SAFELY.

THERE IS A DANGER OF SEVERE ELECTRICAL SHOCK IF THE CUT OFF PLUG IS INSERTED INTO ANY 13 AMP SOCKET.

If a new plug is to be fitted please observe the wiring code as shown below.

If in any doubt please consult a qualified electrician.

Warning: THIS APPLIANCE MUST BE EARTHED.

Important

The wires in this mains lead are coloured in accordance with the following code:

Green-and-yellow:	Earth
Blue:	Neutral
Brown:	Live

As the colours of the wires in the mains lead of this apparatus may not correspond with the coloured markings identifying the terminals in your plug, proceed as follows:

The wire which is coloured GREEN-and-YELLOW must be connected to the terminal in the plug which is marked by the letter E or by the safety earth symbol  coloured GREEN or GREEN-and-YELLOW.

The wire which is coloured Blue must be connected to the terminal which is marked with the letter N or coloured BLACK.

The wire which is coloured Brown must be connected to the terminal which is marked with the letter L or coloured RED.

The mains plug on this equipment must be used to disconnect the mains power.

Please ensure that a socket outlet is available near the equipment and shall be easily accessible.

How to replace the fuse

Open the fuse compartment with a screwdriver and replace the fuse.

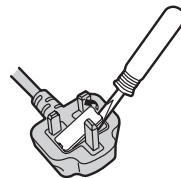

Warnings

- This equipment is not designed for connection to an IT power system.
(An IT system is a system having no direct connections between live parts and Earth; the exposed-conductive-parts of the electrical installation are earthed.
An IT system is not permitted where the computer is directly connected to public supply systems in the U.K.)
- Disconnect the mains plug from the supply socket when the computer is not in use.

This equipment is produced to BS800/1983.

LASER SAFETY INFORMATION

For U.S.A.

Class 1 LASER-Product

This product is certified to comply with DHHS Rules 21 CFR Subchapter J.

This product complies with European Standard EN60825 (or IEC Publication 825)

For all areas

This equipment is classified as a class 1 level LASER product and there is no hazardous LASER radiation.

Caution:

- (1) Use of controls or adjustments or performance of procedures other than those specified herein may result in hazardous radiation exposure.
- (2) The drive is designed to be incorporated into a computer-based system or unit which has an enclosing cover. It should never be used as a stand alone drive.

Danger:

The serviceman should not remove the cover of drive unit and should not service because the drive unit is a nonserviceable part.
Please check DANGER label on PD-drive unit.

- Unplug the AC power cord to the equipment before opening the top cover of the drive.
When the power switch it on, do not place your eyes close to the front panel door to look into the interior of the unit.

LASER Specification

Class 1 level LASER Product

Wave Length: DVD 658±8 nm

CD 775~815 nm

Laser safety information is appropriate only when drive with laser is installed.

SAFETY PRECAUTIONS

1. Before servicing, unplug the power cord to prevent an electric shock.
2. When replacing parts, use only manufacturer's recommended components for safety.
3. Check the condition of the power cord. Replace if wear or damage is evident.
4. After servicing, be sure to restore the lead dress, insulation barriers, insulation papers, shields, etc.

Important Safety Instructions

When using your telephone equipment, basic safety precautions should always be followed to reduce the risk of fire, electric shock and injury to persons, including the following:

1. Do not use this product near water, for example, near a bath tub, wash bowl, kitchen sink or laundry tub, in a wet basement or near a swimming pool.
2. Avoid using a telephone (other than a cordless type) during an electrical storm. There may be a remote risk of electric shock from lightning.
3. Do not use the telephone to report a gas leak in the vicinity of the leak.
4. Use only the power cord and batteries indicated in this manual. Do not dispose of batteries in a fire. They may explode. Check with local codes for possible special disposal instructions.

SAVE THESE INSTRUCTIONS

LITHIUM BATTERY

This computer contains a lithium battery to enable the date, time, and other data to be stored. The battery should only be exchanged by authorized service personnel.

Warning! A risk of explosion from incorrect installation or misapplication may possibly occur.

LITHIUM BATTERY ⚠

• CAUTION

Danger of explosion if battery is incorrectly replaced.
Replace only with the same or equivalent type recommended by the equipment manufacturer.
Dispose of used batteries according to the manufacturer's instructions.

LITHIUMBATTERIES ⚠

Vorsicht!

Explosionsgefahr bei unsachgemäßem Austausch der Batterie. Ersatz nur durch denselben oder einen vom Hersteller empfohlenen ähnlichen Typ. Entsorgung gebrauchter Batterien nach Angaben des Herstellers.

PILE AU LITHIUM ⚠

ATTENTION: IL Y A DANGER D'EXPLOSION S' IL Y A REMPLACEMENT INCORRECT DE LA PILE. REMPLACER UNIQUEMENT AVEC UNE PILE DU MÊME TYPE OU D'UN TYPE RECOMMANDÉ PAR LE CONSTRUCTEUR. METTRE AU RÉBUT LES PILES USAGÉES CONFORMÉMENT AUX INSTRUCTIONS DU FABRICANT.

Precautions (Battery Pack)

Do Not Use with Any Other Product

The battery pack is rechargeable and was intended for the specified product. If it is used with a product other than the one for which it was designed, electrolyte leakage, generation of heat, ignition or rupture may result.

Do Not Charge the Battery Using Methods Other Than Those Specified

If the battery is not charged using one of the specified methods, electrolyte leakage, generation of heat, ignition or rupture may result.

Do Not Throw the Battery Pack into a Fire or Expose It to Excessive Heat

Generation of heat, ignition or rupture may result.

Avoid Extreme Heat (Near the Fire, in Direct Sunlight, for Example)

Electrolyte leakage, generation of heat, ignition or rupture may result.

Do Not Insert Sharp Objects into the Battery Pack, Expose It to Bumps or Shocks, Disassemble, or Modify It

Electrolyte leakage, generation of heat, ignition or rupture may result.

Do Not Short the Positive (+) and Negative (-) Contacts

Generation of heat, ignition or rupture may result. Do not place the battery pack together with articles such as necklaces or hairpins when carrying or storing.

Do Not Use This Product with a Battery Pack Other Than the One Specified

Use only the specified battery pack with your product. Use of battery packs other than those manufactured and supplied by Panasonic may present a safety hazard (generation of heat, ignition or rupture).



A lithium ion battery that is recyclable powers the product you have purchased.

Please call 1-800-8-BATTERY for information on how to recycle this battery.

L'appareil que vous vous êtes procuré est alimenté par une batterie au lithium-ion.

Pour des renseignements sur le recyclage de la batterie, veuillez composer le 1-800-8-BATTERY.

- Do not touch the terminals on the battery pack. The battery pack may no longer function properly if the contacts are dirty or damaged.
- Do not expose the battery pack to water, or allow it to become wet.
- If the battery pack will not be used for a long period of time (a month or more), charge or discharge (use) the battery pack until the remaining battery level becomes 30% to 40% and store it in a cool, dry place.
- This computer prevents overcharging of the battery by recharging only when the remaining power is less than approx. 95% (when Economy Mode (ECO) is enabled: 75%) of capacity.
- The battery pack is not charged when the computer is first purchased. Be sure to charge it before using it for the first time. When the AC adaptor is connected to the computer, charging begins automatically.
- Should the battery leak and the fluid get into your eyes, do not rub your eyes. Immediately flush your eyes with clear water and see a doctor for medical treatment as soon as possible.

NOTE

- The battery pack may become warm during recharging or normal use. This is completely normal.
- Recharging will not commence if internal temperature of the battery pack is outside of the allowable temperature range (0 °C to 55 °C {32 °F to 131 °F}). (→  *Reference Manual* "Battery Power") Once the allowable range requirement is satisfied, charging begins automatically. Note that the recharging time varies based on the usage conditions. (Recharging takes longer than usual when the temperature is 10 °C {50 °F} or below.)
- If the temperature is low, the operating time is shortened. Only use the computer within the allowable temperature range.
- The battery pack is a consumable item. If the amount of time the computer can be run by using a particular battery pack becomes dramatically shorter and repeated recharging does not restore its performance, the battery pack should be replaced with a new one.
- When transporting a spare battery inside a package, briefcase, etc., it is recommended that it be placed in a plastic bag so that its contacts are protected.
- Always power off the computer when it is not in use. Leaving the computer on when the AC adaptor is not connected will exhaust the remaining battery capacity.

CONTENTS

1. Specifications	1-1
2. Names and Functions of Parts.....	2-1
3. Block Diagram	3-1
4. Diagnosis Procedure	4-1
5. Power-On Self Test (Boot Check).....	5-1
6. List of Error Codes <Only when the port replicator is connected>	6-1
7. Self Diagnosis Test	7-1
8. Wiring Connection Diagram	8-1
9. Disassembly/Reassembly	9-1
10. Exploded View	10-1
11. Replacement Parts List	11-1

1. Specifications

This page provides the specifications for the basic model CF-19FHGAXBM/CF-19FDGAXVM. The model number is different according to the unit configuration.

To check the model number:

Check the bottom of the computer or the box the computer came in at the time of purchase.

To check CPU speed, memory size and the hard disk drive (HDD) size:

Run the Setup Utility ( *Reference Manual* "Setup Utility") and select [Information] menu.

[CPU Speed]: CPU speed, [System Memory]: Memory size, [Hard Disk]: Hard disk drive size

Main Specifications

Model No.		CF-19FHGAXBM	CF-19FDGAXVM
CPU		Intel® Core™ 2 Duo Processor U7500 (1.06 GHz, 2 MB ^{†1} L2 cache, 533 MHz FSB)	
Chipset		Intel® GM965	
Memory ^{†2,4}		1 GB (4 GB Max.)	
Video Memory ^{†1,3}		UMA (384 MB Max.)	
Hard Disk Drive ^{†4}		80 GB	
Display Method		10.4 XGA type (TFT)	
Internal LCD ^{†5}		65,536/16,777,216 colors (800 × 600 dots/1024 × 768 dots)	
External Display ^{†6}		65,536/16,777,216 colors (800 × 600 dots/1024 × 768 dots/1280 × 768 dots/1280 × 1024 dots/1440 × 900 dots)	
Wireless LAN ^{†7}			
Bluetooth™ ^{†8}			
LAN		IEEE 802.3 10BASE-T, IEEE 802.3u 100BASE-TX, IEEE 802.3ab 1000BASE-T	
Modem		Data: 56 kbps (V.92) FAX: 14.4 kbps	
Sound		WAVE and MIDI playback, Intel® High Definition Audio subsystem support, Monaural speaker	
Security Chip		TPM (TCG V1.2 compliant) ^{†9}	
Card Slot	PC Card	Type I or Type II x 1 (3.3 V: 400 mA, 5 V: 400 mA)	
	ExpressCard ^{†10}	ExpressCard/34 ^{†11} or ExpressCard/54 x 1	
	Smart Card ^{†12}	ISO7816 x 1	
	SD Memory Card ^{†13}	x 1, Data transfer rate = 8 MB per second ^{†14}	
RAM Module Slot		200-pin, 1.8 V, SO-DIMM, DDR2 SDRAM, PC2-4200 Compliant	
Interface		USB port (4-pin, USB 2.0) x 2, Serial Port (Dsub 9-pin male), Modem port (RJ-11), LAN port (RJ-45), External display port (Mini Dsub 15-pin female), Expansion Bus Connector (Dedicated 100-pin female), External Antenna Connector (Dedicated 50 coaxial connector) x 2, IEEE 1394a Interface Connector (4-pin x 1), Microphone Jack (Miniature jack, 3.5 DIA, Stereo), Headphone Jack (Miniature jack, 3.5 DIA, Impedance 32 Ω, Output Power 4 mW x 2)	
Keyboard / Pointing Device		82 keys / Touch Pad / Touchscreen (Anti-Reflection, Stylus (included) touch capable)	82 keys / Touch Pad / Digitizer (Anti-Reflection)
Power Supply		AC adaptor or Battery pack	
AC Adaptor ^{†15}		Input: 100 V to 240 V AC, 50 Hz/60 Hz, Output: 16.0 V DC, 3.75 A	
Battery Pack		Li-ion 10.65 V, 5.7 Ah	
Operating Time ^{†16}		Approx. 7 hours ^{†17}	
Charging Time ^{†16}	Power on	Approx. 7.5 hours	
	Power off	Approx. 4.5 hours	
Clock Battery		Coin type lithium battery 3.0 V	
Power Consumption ^{†18}		Approx. 30 W ^{†19} / Approx. 60 W (Maximum when recharging in the ON state)	
Physical Dimensions (W × H × D) (excluding the hand strap/shoulder strap)		271 mm × 49 mm × 216 mm {10.7" × 1.93" × 8.5"}	
Weight (excluding the hand strap/shoulder strap)		Approx. 2.30 kg {Approx. 5.06 lb.}	Approx. 2.35 kg {Approx. 5.17 lb.}
Operation Environment		Temperature: 5 °C to 35 °C {41 °F to 95 °F} Humidity: 30% to 80% RH (No condensation)	
Storage Environment		Temperature: -20 °C to 60 °C {-4 °F to 140 °F} Humidity: 30% to 90% RH (No condensation)	

Main Specifications

Operating System	Microsoft® Windows® XP Professional Service Pack 2 with Advanced Security Technologies (NTFS File System)	Microsoft® Windows® XP Tablet PC Edition 2005 (NTFS File System)
Utility Programs	DMI Viewer, Microsoft® Windows® Media Player 10, Adobe Reader, PC Information Viewer, SD Utility, Icon Enlarger, Loupe Utility, Intel® Matrix Storage Manager, Intel® PROSet/Wireless Software ⁷ , Bluetooth™ Stack for Windows® by TOSHIBA ⁸ , Wireless Switch Utility, Hotkey Settings, Battery Recalibration Utility, Panasonic Hand Writing ²⁰ , Software Keyboard ²⁰ , Display Rotation Tool, InMnemon TPM Professional Package ²¹ , Recover Pro™ 6 ²¹ or Recover Pro™ VX ²¹ , Tablet Buttons Settings ²⁰ , Power Saving Utility, Wireless Connection Disable Utility ²¹	
	Setup Utility, Hard Disk Data Erase Utility ²² , PC-Diagnostic Utility	

Wireless LAN <Only for model with wireless LAN>

Intel Wireless WiFi Link 4965AG (802.11 a + b + g) ²³	
Data Transfer Rates ²⁴	IEEE802.11a: 54/48/36/24/18/12/9/6 Mbps (automatically switched) IEEE802.11b: 11/5.5/2/1 Mbps (automatically switched) IEEE802.11g: 54/48/36/24/18/12/9/6 Mbps (automatically switched)
Standards Supported	IEEE802.11a/IEEE802.11b/IEEE802.11g
Transmission method	OFDM system, DSSS system
Wireless Channels Used	IEEE802.11a: Channels 36/40/44/48/52/56/60/64/149/153/157/161/165 IEEE802.11b/IEEE802.11g: Channels 1 to 11
RF Frequency Band	IEEE802.11a: 5.18-5.32 GHz, 5.745-5.825 GHz IEEE802.11b/IEEE802.11g: 2.412-2.462 GHz

Bluetooth™ <Only for model with Bluetooth>

Bluetooth Version	2.0 + EDR
Transmission method	FHSS system
Wireless Channels Used	Channels 1 to 79
RF Frequency Band	2.402-2.48 GHz

¹ 1 MB = 1,048,576 bytes

² You can physically expand the memory upto 4 GB, but the total amount of usable memory available will be less depending on the actual system configuration.

³ A segment of the main memory is allotted automatically depending on the computer's operating status. The size of the Video Memory cannot be set by the user.

⁴ 1 GB = 1,000,000,000 bytes. Your operating system or some application software will report as fewer GB.

⁵ A 16,777,216 color display is achieved by using the dithering function.

⁶ Maximum resolution depends on the specifications of the external display.

⁷ Only for model with wireless LAN

⁸ Only for model with Bluetooth

⁹ For information on TPM, click [start] - [Run] and input "c:\util\drivers\tpm\README.pdf", and refer to the Installation Manual of "Trusted Platform Module (TPM)".

¹⁰ Only for model with ExpressCard slot

¹¹ When using ExpressCard/34, the card slot cover cannot be closed.

¹² Only for model with Smart Card slot

¹³ SD Memory Cards that support high-speed transfer rates can be used. Windows Ready Boost function is also supported. Operation has been tested and confirmed using Panasonic SD Memory Cards and SDHC Memory Cards with a capacity of up to 8 GB. Operation on other SD equipment is not guaranteed.

¹⁴ This computer is not compatible with MultiMediaCards. Do not insert this kind of cards.

¹⁴ Theoretical value and not the actual speed. The transfer rate does not become higher even if you use a card that supports the higher transfer rate.

¹⁵ <Only for North America>

The AC adaptor is compatible with power sources up to 240 V AC adaptor. The computer is supplied with a 125 V AC compatible AC cord. ^{20-M-2-1}

¹⁶ Varies depending on the usage conditions.

¹⁷ Measured using MobileMark™ 2005 (LCD brightness: 60 cd/m²)

¹⁸ Approx. 0.9 W when the battery pack is fully charged (or not being charged) and the computer is OFF.

¹⁹ Rated power consumption ^{23-E-1}

²⁰ Only for model with Windows XP Professional

²¹ You need to install to use the feature.

²² The Product Recovery DVD-ROM is required.

²³ It does not correspond to IEEE802.11.n.

²⁴ These are speeds specified in IEEE802.11a+b+g standards. Actual speeds may differ.

2. Names and Functions of Parts

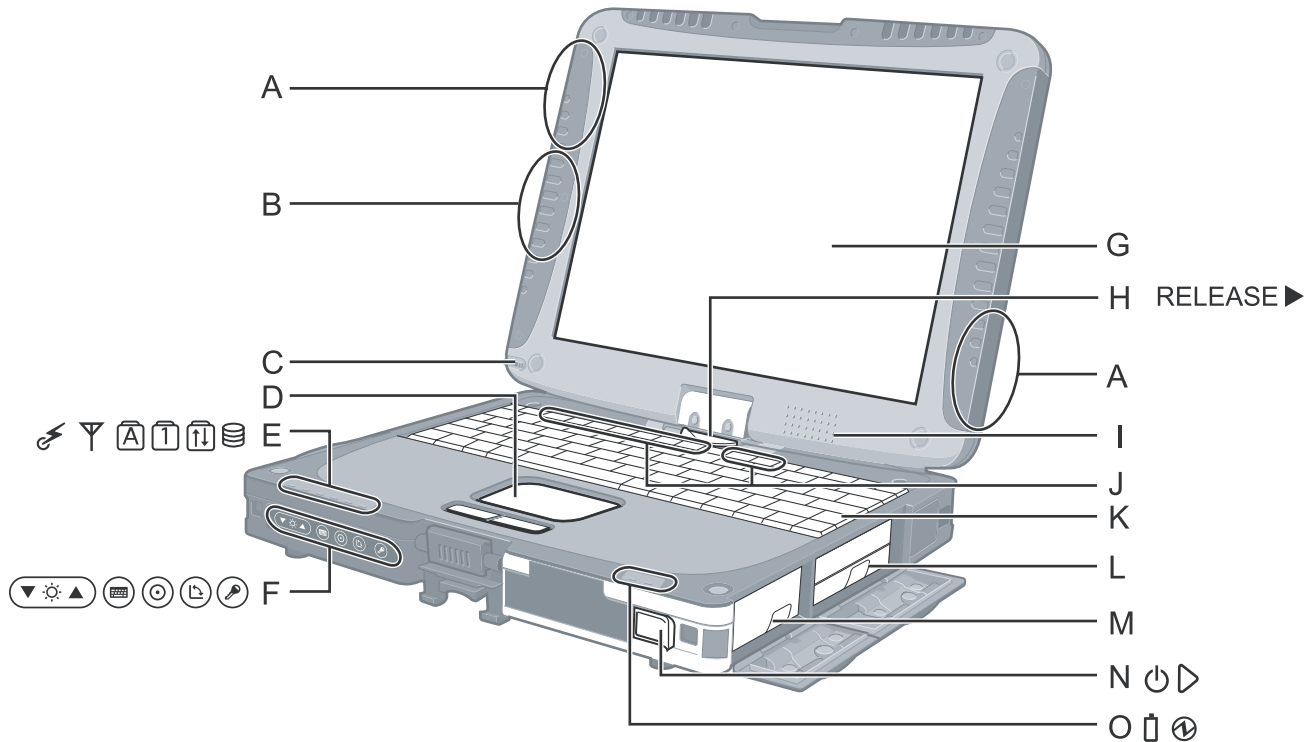

A: Wireless LAN Antenna

<Only for model with wireless LAN>

Reference Manual "Wireless LAN"

B: Bluetooth Antenna

<Only for model with Bluetooth>

Reference Manual "Bluetooth"

C: Stylus/Pen Holder

D: Touch Pad

E: LED Indicator

: Wireless ready
This indicator lights when Wireless LAN, Bluetooth, and/or Wireless WAN are connected and ready. It does not necessarily indicate the On/Off condition of the wireless connection.

Reference Manual "Disabling / Enabling Wireless Communication"

: Wireless WAN status
<Only for model with wireless WAN>
Refer to the instruction manual of the wireless device.

: Caps lock

: Numeric key (NumLk)

: Scroll lock (ScrLk)

: Hard disk drive status

F: Tablet Buttons

Reference Manual "Tablet Buttons"

G: LCD

<Only for model with touchscreen>

Reference Manual "Touchscreen"

<Only for model with digitizer>

Reference Manual "Digitizer"

H: Display Release Latch

I: Speaker

Reference Manual "Key Combinations"

J: Function Key

Reference Manual "Key Combinations"

K: Keyboard

L: Hard Disk Drive

Reference Manual "Hard Disk Drive"

M: Battery Pack

N: Power Switch

O: LED Indicator

: Battery status

Reference Manual "Battery Power"

: Power status

(Off: Power off/Hibernation, Green: Power on, Blinking green: Standby)

Left side

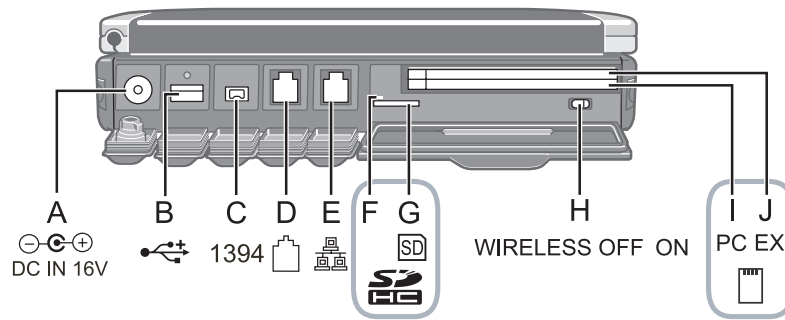

Rear side

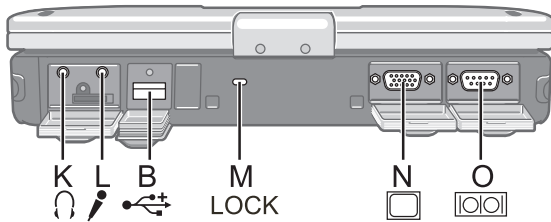

Bottom

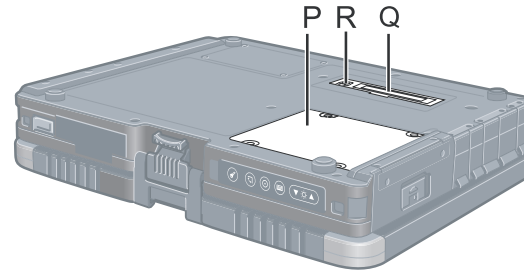

A: DC-IN Jack

B: USB Port

→ Reference Manual "USB Devices"

C: IEEE 1394 Interface Connector

→ Reference Manual "IEEE 1394 Devices"

D: Modem Port

→ Reference Manual "Modem"

E: LAN Port

→ Reference Manual "LAN"

F: SD Memory Card Indicator

(Blinking: During access)

→ Reference Manual "SD Memory Card"

G: SD Memory Card Slot

→ Reference Manual "SD Memory Card"

H: Wireless Switch

→ Reference Manual "Disabling / Enabling Wireless Communication"

I: <for model without Smart Card Slot>

PC Card Slot

→ Reference Manual "PC Card / ExpressCard"

<for model with Smart Card Slot>

Smart Card Slot

→ Reference Manual "Smart Card"

J: <for model without Smart Card Slot>

ExpressCard Slot

→ Reference Manual "PC Card / ExpressCard"

<for model with Smart Card Slot>

PC Card Slot

→ Reference Manual "PC Card / ExpressCard"

K: Headphone Jack

You can connect headphones or amplified speakers. When they are connected, audio from the internal speakers is not heard.

L: Microphone Jack

A condenser microphone can be used. If other types of microphones are used, audio input may not be possible, or malfunctions may occur as a result.

- When recording in stereo using a stereo microphone:
Click [start] - [All Programs] - [SoundMAX] - [Control Panel] and select [Microphone], and then add a check mark for [No Filtering] in [Microphone Enhancements].
- When using a monaural microphone with a 2-terminal plug:
Click [start] - [All Programs] - [SoundMAX] - [Control Panel] and select [Microphone], and then add a check mark for [Voice Recording] in [Microphone Enhancements].
Otherwise, only audio on the left track will be recorded.

M: Security Lock

A Kensington cable can be connected. For further information, read the manual that comes with the cable.

N: External Display Port

→ Reference Manual "External Display"

O: Serial Port

P: RAM Module Slot

→ Reference Manual "RAM Module"

Q: Expansion Bus Connector

→ Reference Manual "Port Replicator / Car Mounter"

R: External Antenna Connector

3 Block Diagram

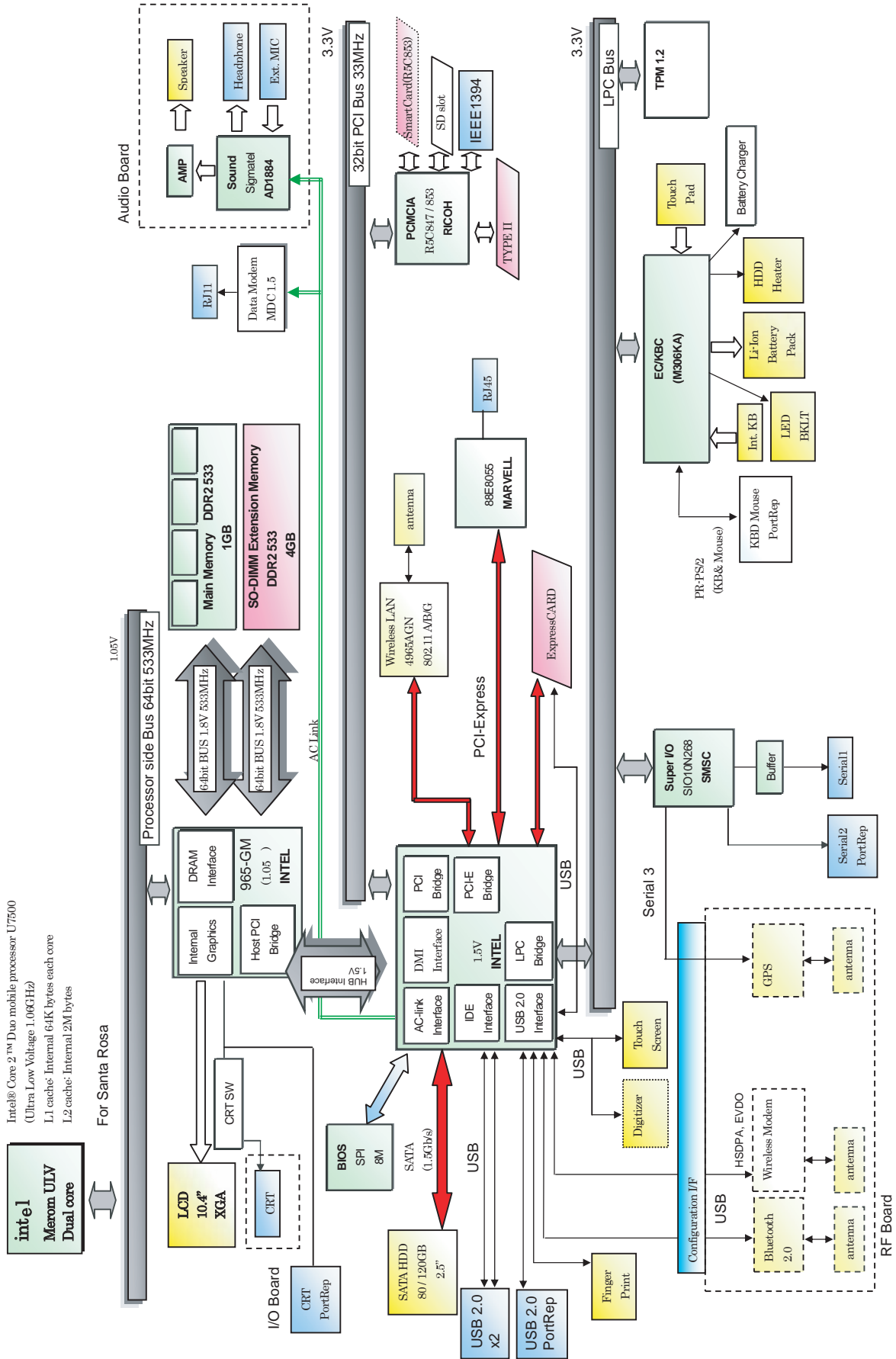

4 Diagnosis Procedure

4.1. Basic Procedures

The basic procedures for diagnosis, disassembly, and test of defective parts of a set to be repaired are summarized below. For details, refer to relevant pages in the Service Manual.

● Flow Chart

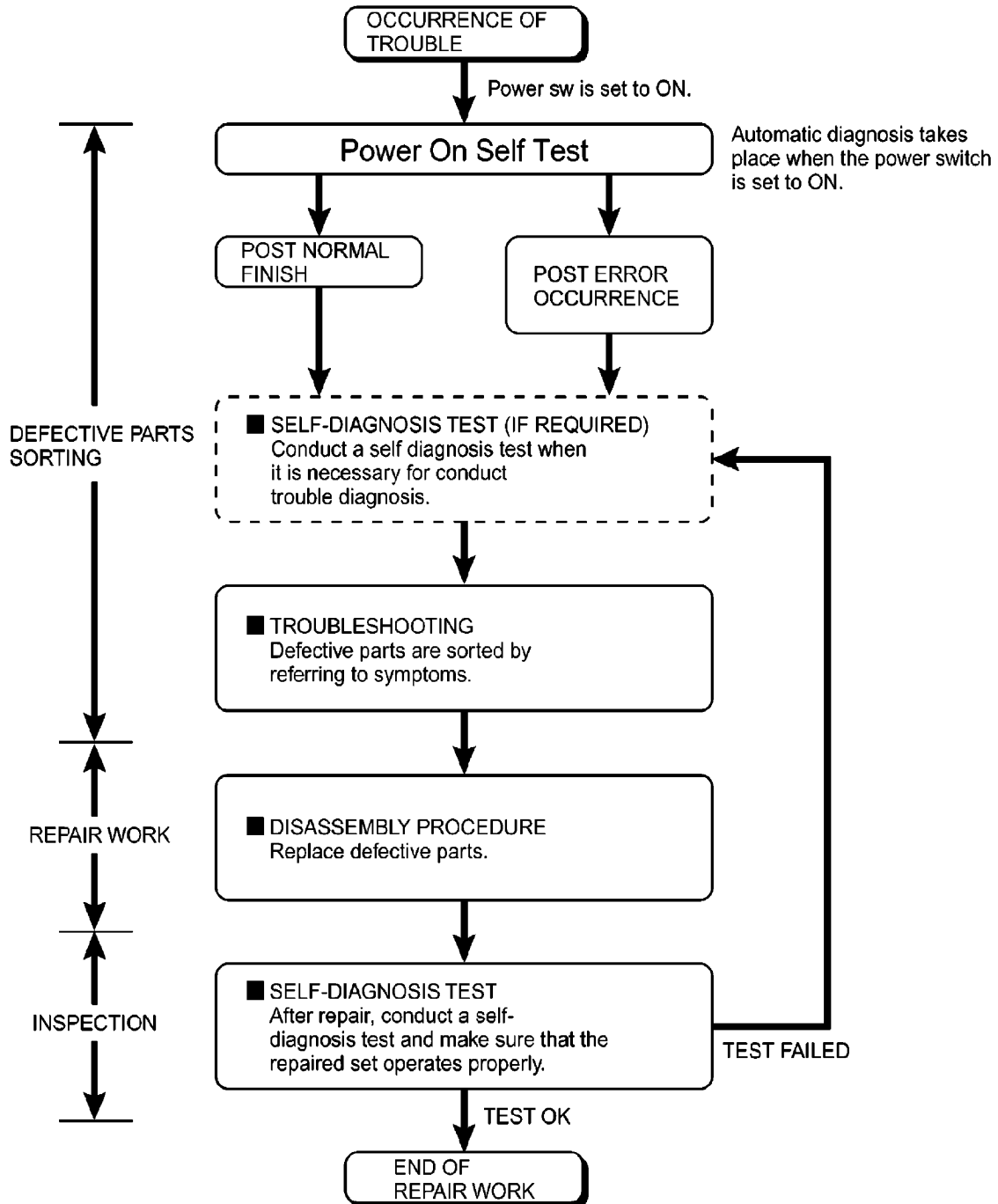

4.2. Troubleshooting

Please take note of the following two points with regard to troubleshooting:

1. Know-how of diagnosis upon occurrence of heavy troubles, e.g. Set cannot be turned ON, Set fails to start, No display on screen, etc.
2. Explanation of each trouble, mainly symptom of trouble in operation.

● Flow Chart

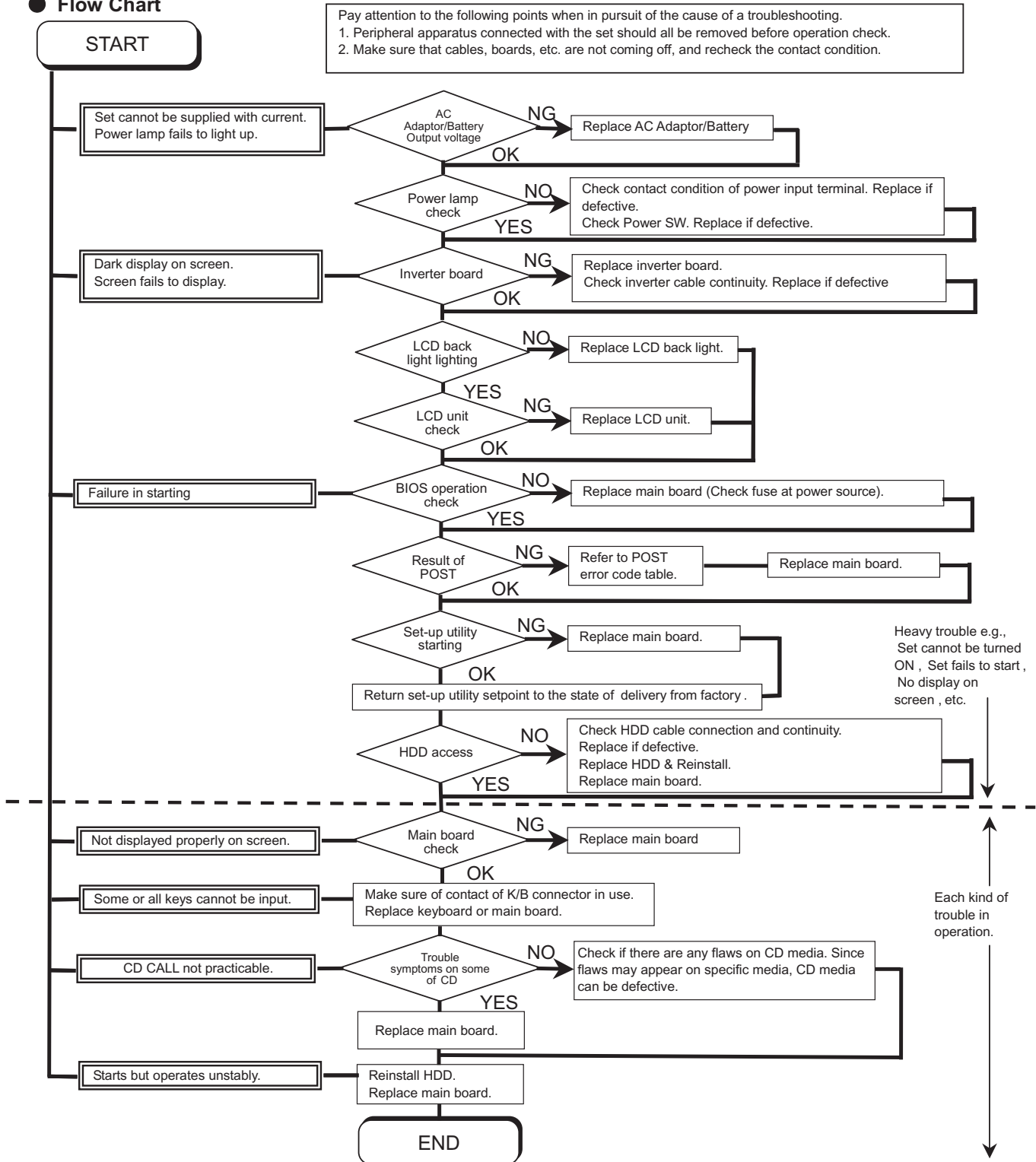

5 Power-On Self Test (Boot Check)

Outline of POST

The set has a boot check function called POST (Power-On Self Test) in it.

The condition of the main body is diagnosed by checking beep sound or error code.

StartTest begins automatically when power switch is set to ON.

Normal finishAfter memory checking, a beep sound is issued once and the set is placed into automatic stop.

Note: If no error occurs, nothing is displayed. (No display of OK, etc.)

Error Diagnosis by Checking Beep Signal Sound

The beep sound is as follows:



(Length of bar shows length of sound.)

■ = long sound (about 0.4 sec.), ■ = short sound (about 0.2 sec.), Length between sounds is about 0.1 sec.

Table of errors classified by beep sounds

Diagnosis	Beep signal sound	Error message
Main board	1(long sound)-2	BIOS ROM error
	1-2-2-3	BIOS ROM error
	1-3-1-1	RAM error
	1-3-1-3	Keyboard controller error
	1-3-4-1	RAM error
	1-3-4-3	RAM error
	1-4-1-1	RAM error
	2-1-2-3	BIOS ROM error
	2-2-3-1	Occurrence of unexpected offering

(Note) A beep sound is also issued in case of other I/O trouble.

6 List of Error Codes <Only when the port replicator is connected>

The following is a list of the messages that BIOS can display. Most of them occur during POST. Some of them display information about a hardware device, e.g., the amount of memory installed. Others may indicate a problem with a device, such as the way it has been configured. Following the list are explanations of the messages and remedies for reported problems. If your system displays one of except the messages marked below with an asterisk (*), write down the message and contact Panasonic Technical Support. If your system fails after you make changes in the Setup menus, reset the computer, enter Setup and install Setup defaults or correct the error.

0200 Failure Fixed Disk

Fixed disk in not working or not configured properly. Check to see if fixed disk is attached properly. Run Setup. Find out if the fixed-disk type is correctly identified.

0210 Stuck key

Stuck key on keyboard.

0211 Keyboard error

Keyboard not working.

0212 Keyboard Controller Failed

Keyboard controller failed test. May require replacing keyboard controller.

0213 Keyboard locked - Unlock key switch

Unlock the system to proceed.

0230 System RAM Failed at offset : *nnnn*

System RAM failed at offset *nnnn* of in the 64k block at which the error was detected.

0231 Shadow RAM Failed at offset : *nnnn*

Shadow RAM failed at offset *nnnn* of the 64k block at which the error was detected.

0232 Extended RAM Failed at offset : *nnnn*

Extended memory not working or not configured properly at offset *nnnn*.

0250 System battery is dead - Replace and run SETUP

The CMOS clock battery indicator shows the battery is dead. Replace the battery and run Setup to reconfigure the system.

***0251 System CMOS checksum bad - Default configuration used**

System CMOS has been corrupted or modified incorrectly, perhaps by an application program that changes data stored in CMOS. The BIOS installed Default SETUP Values. If you do not want these values, enter Setup and enter your own values. If the error persists, check the system battery or contact Panasonic Technical Support.

0260 System timer error

The timer test failed. Requires repair of system board.

0270 Real time clock error

Real-time clock fails BIOS test. May require board repair.

***0280 Previous boot incomplete - Default configuration used**

Previous POST did not complete successfully. POST loads default values and offers to run Setup. If the failure was caused by incorrect values and they are not corrected, the next boot will likely fail. On systems with control of **wait states**, improper Setup settings can also terminate POST and cause this error on the next boot. Run Setup and verify that the wait-state configuration is correct. This error is cleared the next time the system is booted.

0281 Memory Size found by POST differed from EISA CMOS

Memory size found by POST differed from EISA CMOS.

02D0 System cache error - Cache disabled

Contact Panasonic Technical Support.

02F0: CPU ID:

CPU socket number for Multi-Processor error.

02F4: EISA CMOS not writable

ServerBIOS2 test error: Cannot write to EISA CMOS.

02F5: DMA Test Failed

ServerBIOS2 test error: Cannot write to extended DMA (Direct Memory Access) registers.

02F6: Software NMI Failed

ServerBIOS2 test error: Cannot generate software NMI (Non-Maskable Interrupt).

02F7: Fail - Safe Timer NMI Failed

ServerBIOS2 test error: Fail-Safe Timer takes too long.

device address Conflict

Address conflict for specified *device*.

Allocation Error for: *device*

Run ISA or EISA Configuration Utility to resolve resource conflict for the specified *device*.

Failing Bits : *nnnn*

The hex number *nnnn* is a map of the bits at the RAM address which failed the memory test. Each 1 (one) in the map indicates a failed bit. See error 230,231 or 232 for offset address of the failure in System, Extended or Shadow memory.

Invalid System Configuration Data

Problem with NVRAM (CMOS) data.

I/O device IRQ conflict

I/O device IRQ conflict error.

Operating System not found

Operating system cannot be located on either drive A: or drive C:. Enter Setup and see if fixed disk and drive A: are properly identified.

Parity Check 1 *nnnn*

Parity error found in the system bus. BIOS attempts to locate the address and display it on the screen. If it cannot locate the address, it displays ????. Parity is a method for checking errors in binary data. A parity error indicates that some data has been corrupted.

Parity Check 2 *nnnn*

Parity error found in the I/O bus. BIOS attempts to locate the address and display it on the screen. If it cannot locate the address, it displays ????.

Press <F1> to resume, <F2> to Setup

Displayed after any recoverable error message. Press <F1> to start the boot process or <F2> to enter a Setup and change the settings. Write down and follow the information shown on the screen.

7 Self Diagnosis Test

As for the self-diagnosis test(PC-Diagnostic utility) to use this model, a standard test and the enhancing test by the module of the main body building in are possible.

Notes To skip BIOS password

Use <Ctrl>+<F10> key to skip BIOS password or authentication of fingerprint.

This key is only for entering DIAG mode. Not available to boot the computer.

If customer set "HDD Lock", the DIAG program cannot perform HDD test.

*This key is for service purpose only. Do not disclose this information to unrelated others.

1. Beginning of self-diagnosis test

1-1. Setting of content of setup

1. The power supply of the computer is turned on.
2. " F2 " is pushed on the screen of "Panasonic" while " press <F2 to enter Setup> " is displayed.
3. The setup utility starts and then takes notes of the content of the BIOS setup of present set.
4. " F9 " is pushed, " Yes" is selected on the screen of " Is the default value loaded? ", and " Enter" is pushed.
5. " F10 " is pushed.
6. " Yes" is selected on the screen of the setup confirmation, and " Enter" is pushed.
7. The computer starts automatically.

Attention

- If the device which can be set is set to "Invalidity" by "Advanced" or "Security" menu, becomes an error by "PC-Diagnostic utility".
(It is judged that the device which can be set to "Invalidity" by "Main" menu such as "Flat pad" is normal if the controller operates normally though sets to "Invalidity" by the setup.)
- In the model with built-in DVD of the USB connection, even if DVD is normal, becomes an error if legacy USB is set to "Invalidity"

1-2. When you execute an automatic test

1. "Ctrl" + "F7" is pushed while the "Panasonic" start screen is displayed after the computer is started.
2. The test of all devices begins automatically by "PC-Diagnostic utility" 's starting.

Attention

- It is a test which the customer who bought PC can execute. (As for HDD, the enhancing test is also possible.)
- A flat pad does not work for a while after starting "PC-Diagnostic utility".
- The movement of a flat pad might become abnormal If after RAM begins from the CPU/System test, a flat pad will be operated in about 30 seconds. In that case, restarts pushing "Alt" + "Ctrl" + "Del" key. Or, please start "PC-Diagnostic utility" again after doing the power supply switch in the slide, and turning off the power supply.

1-3. When you execute the enhancing test

1. Please let me discontinue diagnosing clicking  to end an automatic test.
2. Please click on the character of "D" "PC-Diagnostic utility" on the screen while pushing both of right "Shift" and left "Shift" keys.



3. All devices which can select the enhancing test make the setting of the enhancing test possible.
4. The district device is made "FULL" display (enhancing test).
5. The test begins clicking .

*Please refer to item 4 for the error result of each test and the division of the breakdown part.

2. Operation of PC-Diagnostic Utility

- Only the device which can be inspected on the entire screen is displayed.
- The item does not appear when the device of wireless LAN etc. is not physically connected.
- The movement of the item must use an arrow key or a flat pad.



- As for the device under the diagnosis, blue and yellow are alternately displayed at the left of the icon.
- The diagnosis result of the device greens at the left of the icon when it is normal, and becomes red when abnormal.

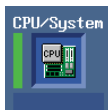

- When the test of all devices ends, the test result is displayed under the right of the screen.



- Please click while diagnosing when being stop on the way by the time the test of all devices ends.
- Please click when you restart "PC-Diagnostic utility".
- *Each device is tested from the beginning, and it is not possible to restart on the way.
- When the test of all devices ends, the test result is displayed under the right of the screen.

2-1. Selection of tested device

- To test only a specific device, "Test" and "Do not test" of each device can be selected.
- The device which can select the enhancing test changes in order of "The standard is tested" and "Do not test" whenever the device icon is clicked.



Start the standard test



Do not test

Please begin testing clicking  if the selection of the tested device ends.

2-2. "PC-Diagnostic utility" End method

When of "Close" on the right of the screen is clicked, the computer reactivates automatically. Or, the power supply switch is done in the slide and the power supply is turned off.

2-3. The content of the setup is returned to the setting of the user

1. Turned on the computer.
2. "F2" is pushed on the screen while "Press<F2>to enter Setup" is displayed of "Panasonic".
3. Push "F10", and on the screen of "Is the change in the setting preserved and do end?"and then "Yes" is selected, and "Enter" is pushed.
4. The computer reactivates automatically.
5. The end option is chosen by the start menu, and the power supply of the computer is turned off.

Standard at test time

All devices other than RAM and HDD ----- about 1 minute
RAM standard test ----- 1 - 2 minutes
HDD standard test ----- 2 - 3 minutes
HDD enhancing test (60GB) ----- about 40 minutes

Ex.The standard when the standard <all device> is tested becomes $1+2+3=6$ minutes.

There is greatly a difference from RAM test when the memory is increased according to the performance of the memory occasionally.

Moreover, when the main body of PC under the test is a high temperature, it occasionally takes time.

There is greatly a difference from HDD according to the performance of the drive occasionally.

3. Test Item and Division of trouble

Test item	Standard	Enhancing	Content of standard test	Content of enhancing test	Place with possibility of breakdown
CPU / SYSTEM	○	—	CPU is shifted to protected mode, and "Violation of the paging", "Operation of the violation of a privileged instruction", and DMA, INT, TIMER, and the RTC operation are confirmed.	—	CPU / Main board
RAM	○	—	All memory space is tested in a special memory access pattern based on "R.S.T . technology".	—	Memory / Mainboard
HDD	○	○	The record area frequently accessed with Microsoft Windows XP to test in about two minutes regardless of points of HDD is emphatically tested.	All record area is tested.	HDD / Mainboard / Cable / Connector
MODEM	○	—	It is confirmed not to find abnormality in the AC97 modem controller.	—	MODEM/ Mainboard
Wireless LAN	○	—	It is confirmed not to find abnormality in the Wireless LAN modem controller.	—	Wireless LAN board / Connector / Mainboard
Sound *5	○	—			
USB	○	○ ^{*1}	It is confirmed not to find abnormality in the USB controller.	It is confirmed not to find abnormality in the wiring between the USB controller and the connector by confirming the connection of the USB equipment connected with the USB connector.	Mainboard / Connector
LAN	○	○ ^{*2}	It is confirmed not to find abnormality in the LAN controller.	It is confirmed not to find abnormality in the wiring between the controller and the connector by connecting to HUB with LAN cable.	Mainboard / Connector
PC Card	○	—	It is confirmed not to find abnormality in the CardBus controller.	—	Mainboard
SD	○	—	It is confirmed not to find abnormality in the SD controller.	—	Mainboard
Keyboard	○	○ ^{*3}	It is confirmed not to find abnormality in keyboard controller's keyboard interface.	The key is actually input, and the operation is displayed on the screen.	Mainboard / Keyboard
Touch Pad	○	○ ^{*4}	Whether keyboard controller's mouse interface operates normally is confirmed.	The operation is actually displayed on the screen by operating the touch pad.	Mainboard / Touch Pad
DVD-ROM	○	○ ^{*6}	The drive is normally reset, and it is accessible is confirmed.	It is confirmed to be able to read media normally.	Mainboard / DVD Drive / DVD Cable / DVD Connector

Test Item	Standard	Enhanced	Content of Standard Test	Content of Extend Test	The place with possibility of breakdown
Touch Screen	○	○	It is confirmed not to find abnormality in the USB connection of Touch Screen. This test cannot find abnormality of Touch Screen.	Perform Touch Screen functionality practically. Operator has to judge PASS/FAIL with test result.	Main board/ Touch Screen
Bluetooth	○		It is confirmed not to find abnormality in the connection of Main board and Bluetooth module.	—	Bluetooth cable
Wireless WAN	○	—	It is confirmed not to find abnormality in the connection of Main board and Wireless WAN module.	—	WWAN cable
Floppy	○	—	It is confirmed not to find abnormality in the legacy FD drive. This test cannot find abnormality of mechanical breakdown. (e.g., Head, Motor)	—	FD Drive/ Main board (Super I/O)/ FDD cable FDD connector
Video	○	—	It is confirmed not to find abnormality in access to VRAM with VESA. The PC which uses main memory as VRAM may fail with main memory failure.	—	Main board (Chipset, Graphic Controller)/ Memory
GPS	○	—	It is confirmed not to find abnormality in the connection of Main board and GPS	—	GPS cable
IEEE1394	○	—	It is confirmed not to find abnormality in the IEEE1394 controller.	—	Main board (IEEE1394 Controller)
Express Card	—	○	—	It is confirmed not to find abnormality in the wiring between Chipset and Express Card.	Main board (Chipset)/ Express Card Connector
Smart Card	○	—	It is confirmed not to find abnormality in the Smart Card controller.	—	Main board (Smart Card Controller)
Serial Port	○	○ *7	It is confirmed not to find abnormality of Super I/O UART function. This test cannot find lack of wiring between Super I/O and Serial Connector.	It is confirmed not to find abnormality in the wiring between Super I/O and Serial Connector. This test cannot find failure of cable characteristic and device problems.	Main board (Super I/O)/ Serial Connector
Parallel Port	○	○ *8	It is confirmed not to find abnormality of Super I/O parallel function. This test cannot find lack of wiring between Super I/O and Parallel Connector.	It is confirmed not to find abnormality in the wiring between Super I/O and Parallel Connector. This test cannot find failure of cable characteristic and device problems.	Main board (Super I/O)/ Parallel Connector

*1 Please connect the USB device with the port (USB connector) which wants to test before the tests.

*2 Please connect LAN port with LAN HUB with LAN cable before the tests.

*3 The operator actually inputs the key, and the operator judges PASS/FAIL of the test.

*4 The operator actually operates the mouse, and the operator judges PASS/FAIL of the test.

*5 It is not abnormal though the sound is emitted from the speaker while testing.

※ When the test result is PASS, trouble is thought by not hearing of the sound under the test from the speaker and the headphone by the wiring of the audio output system.

*6 Please set DVD/CD media in the drive before the tests.

*7 Please set a Special Loop Back Connector Tool at serial connector for Enhanced Test. (This Connector Tool is same as the one used before.)

*8 Please set a Special Loop Back Connector Tool at parallel connector for Enhanced Test. (This Connector Tools is same as the one used before.)

8 Wiring Connection Diagram

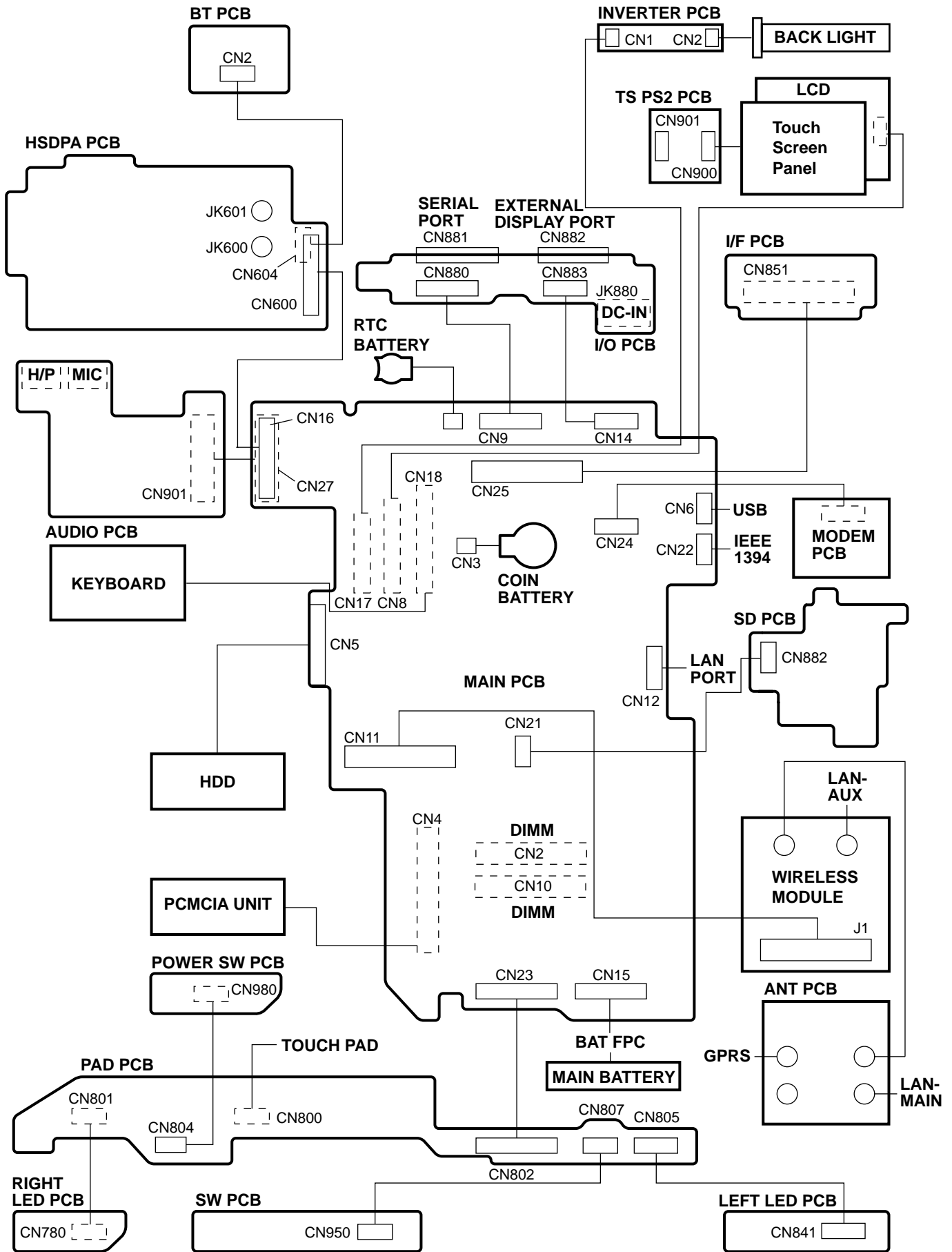

9 Disassembly/Reassembly

Note:

Power off the computer. Do not shut down to the Suspend or hibernation mode.

Do not add peripherals while the computer is in the Suspend or hibernation mode; abnormal operation may result.

9.1. Disassembly Instructions

9.1.1. Preparation

Before disassembling, be sure to make the following preparations.

- Shut down Windows and turn off the power.
- Disconnect the AC adaptor.
- Remove the optional DIMM memory card and PCMCIA card if they are connected.
- Remove other devices if they are connected.

Attention:

- Please execute writing BIOS ID when you exchange the Main Board.
- Parts (Sheet and rubber) etc. related various the Conductive Cloth and Heat Spreader cannot be recycled. Use new parts.

9.1.2. Removing the Battery Pack and HDD Pack

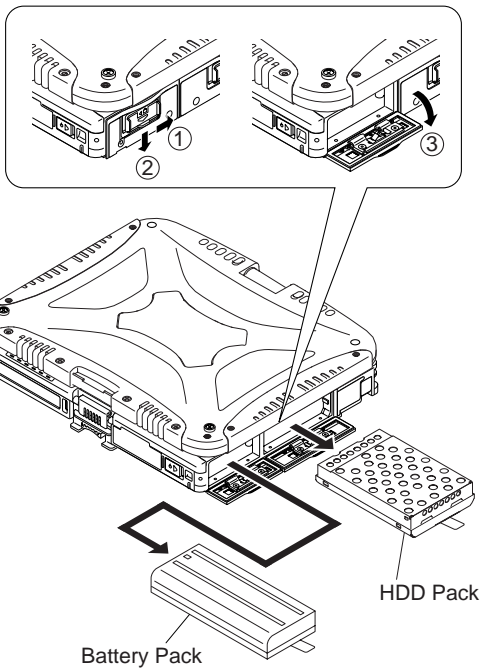

1. Open the Battery Cover.
2. Remove the Battery Pack.
3. Open the HDD Cover.
4. Remove the HDD Pack.

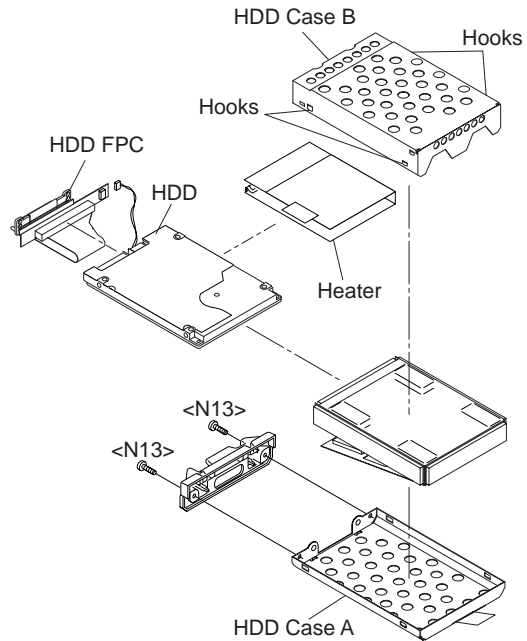

5. Remove the two Screws <N13>.
6. Remove the HDD Case A and the HDD Case B.
7. Remove the HDD

Screws <N13> : DXQT2+D4FNL

9.1.3. Removing the Touch Pad and Keyboard

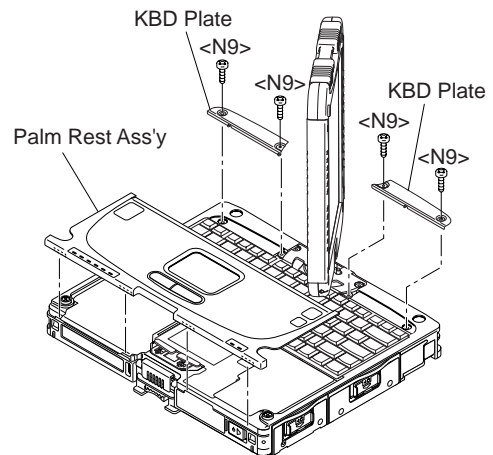

1. Remove the Palm Rest Ass'y.

Note:

The Palm Rest Ass'y is firmly fixed with two-sided tape.

Carefully remove the Palm Top Cover Sheet not to damage it.

2. Remove the 4 Screws <N9>.
3. Remove the KBD Plate.

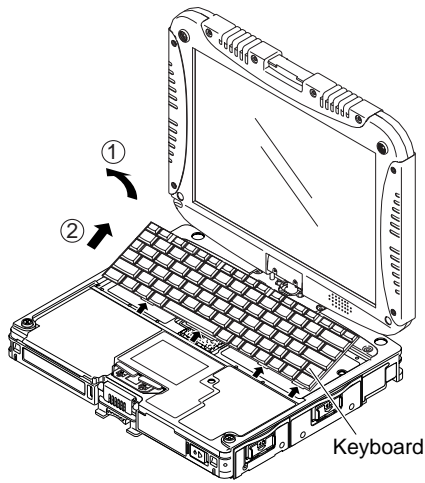

4. Lift the far side of the Keyboard and slide it to backward, and then turn the Keyboard over frontward.

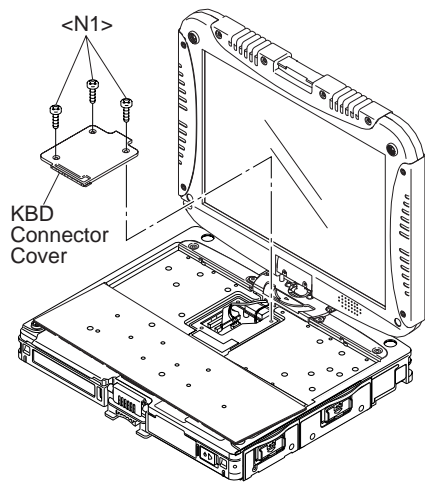

5. Remove the 3 Screws <N1>.
6. Remove the KBD Connector Cover.

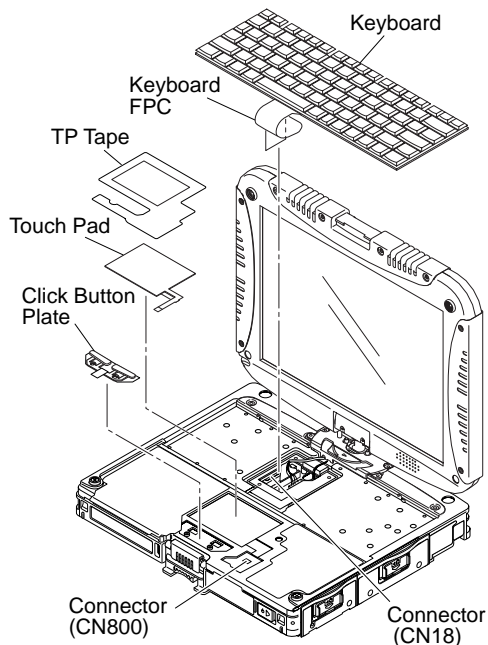

7. Disconnect the Cable from Connector (CN18).
8. Remove the Keyboard.
9. Remove the TP Tape.

10. Disconnect the Cable from Connector (CN800).
11. Remove the Touch Pad and Click Button Plate.

Screws <N1> : DFHE5025XA
Screws <N9> : DRSB2+5FKL

9.1.4. Removing the DIMM Lid Ass'y

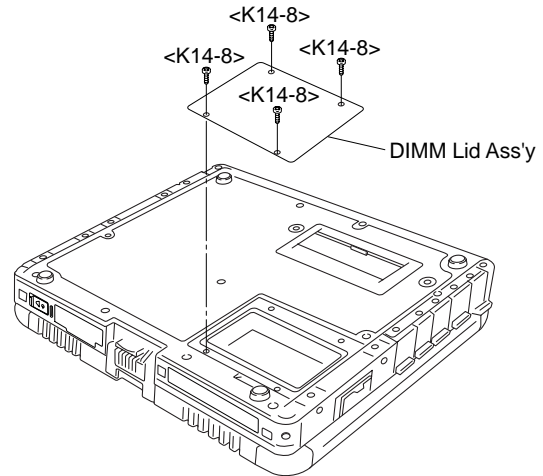

1. Remove the 4 Screws <K14-8>.
2. Remove the DIMM Lid Ass'y.

Screws <K14-8> : DRHM5025YAT

9.1.5. Removing the Rear Cabinet

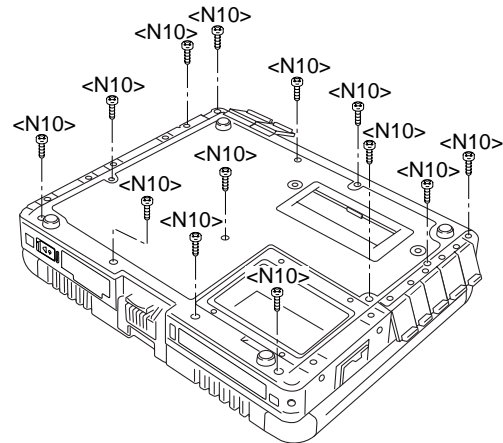

1. Remove the 13 Screws <N10>.
2. Open the LID Rubbers.
3. Remove the Rear Cabinet.

Screws <N10> : DRHM0061ZA

9.1.6. Removing the DU Lid Unit

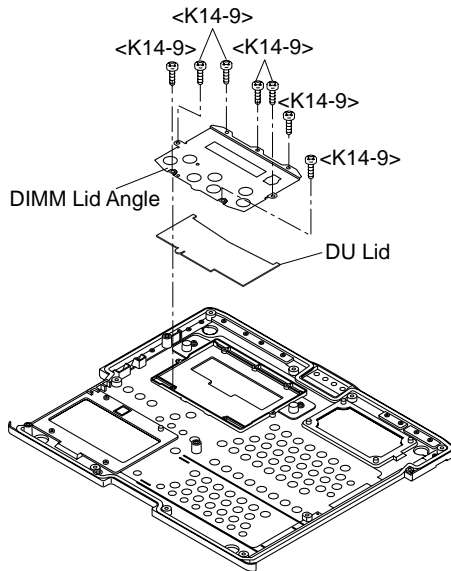

1. Remove the 7 Screws <K14-9>.
2. Remove the DU Lid Angle and DU Lid.

Screws <K14-9> : DXQT2+D25FNL

9.1.7. Removing the HSDPA PCB and Bluetooth PCB

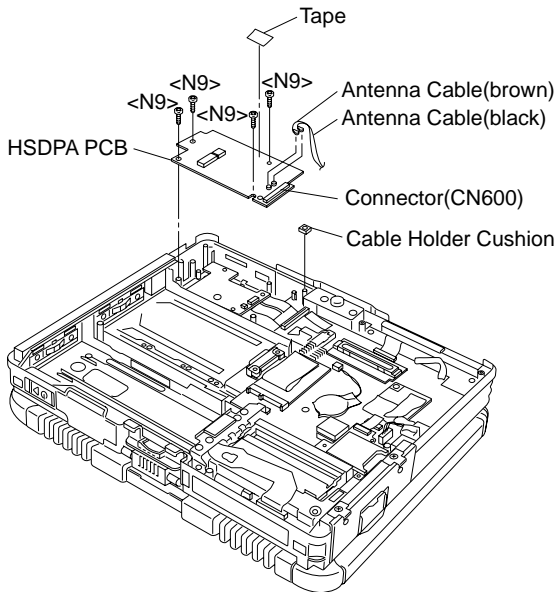

1. Remove the Cable Holder Cushion.
2. Disconnect the 2 Antenna Cables (brown, black).
3. Remove the Tape.
4. Remove the 4 Screws. <N9>
5. Disconnect the Cable from the Connector (CN600).

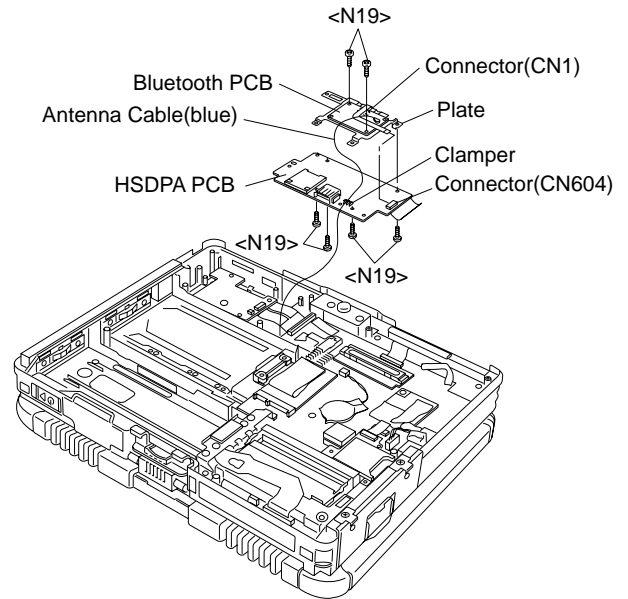

6. Disconnect the Antenna Cable from the Clamper.
7. Disconnect the Antenna Cable.
8. Remove the 4 Screws. <N19>
9. Disconnect the Cable from the Connector (CN604).
10. Remove the 2 Screws. <N19>
11. Disconnect the Cable from the Connector (CN1) and remove the Bluetooth PCB and HSDPA PCB.

Screws <N9> : DRSB2+5FKL

Screws <N19> : XSB2+3FNL

9.1.8. Removing the Audio PCB

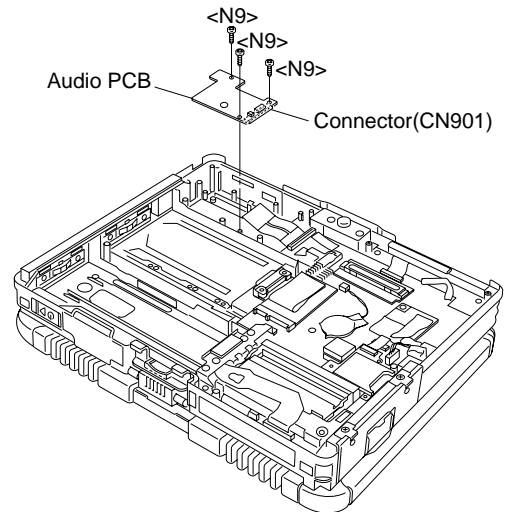

1. Remove the 3 Screws <N9>.
2. Disconnect the Cable from a Connector (CN901).
3. Remove the Audio PCB.

Screws <N9>:DRSB2+5FKL

9.1.9. Removing the Main PCB, Wireless Module, SD PCB, Antenna PCB and Modem PCB

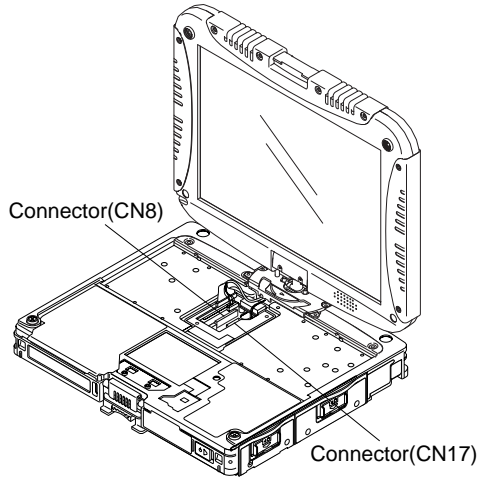

Note:

This procedure is not necessary if the computer is not equipped with Wireless Module or Modem PCB.

1. Disconnect the 2 LCD Cables. (CN8,CN17)

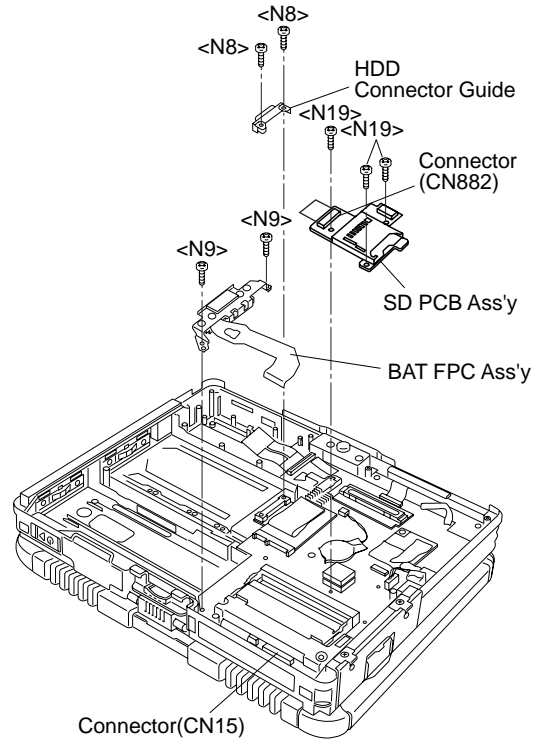

5. Remove the 2 Screws <N8>, and remove the HDD Connector Guide.
6. Remove the 2 Screws. <N9>
7. Disconnect the Cable from the Connector. (CN15)
8. Remove the BAT FPC Ass'y.
9. Remove the 3 Screws. <N19>
10. Disconnect the Cable from the Connector (CN21), and remove the SD PCB Ass'y.

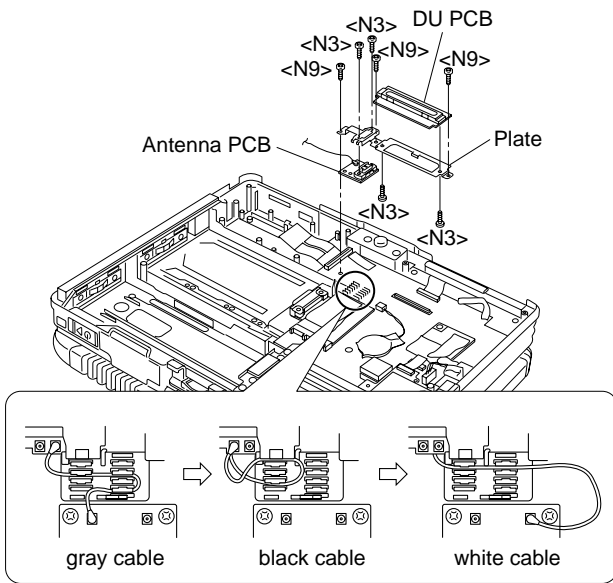

2. Remove the gray, black and white Antenna Cables.
3. Remove the 2 Screws <N3> and the 3 Screws <N9>.
4. Remove the 2 screws <N3>, and remove the DU PCB, Plate and Antenna PCB.

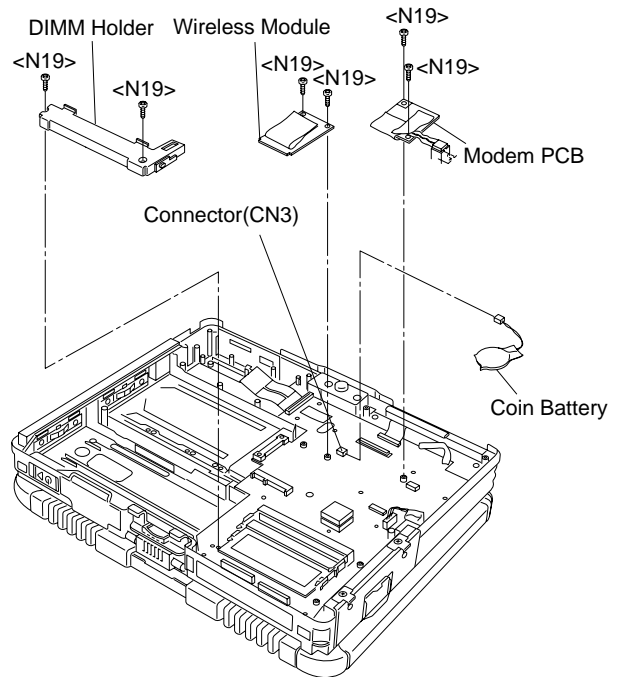

11. Disconnect the Cable from the Connector (CN3), and remove the Coin Battery.
12. Remove the 2 Screws <N19>, and remove the Wireless Module.
13. Remove the 2 Screws <N19>, and remove the Modem PCB.

14. Remove the 2 Screws <N19>, and remove the DIMM Holder.

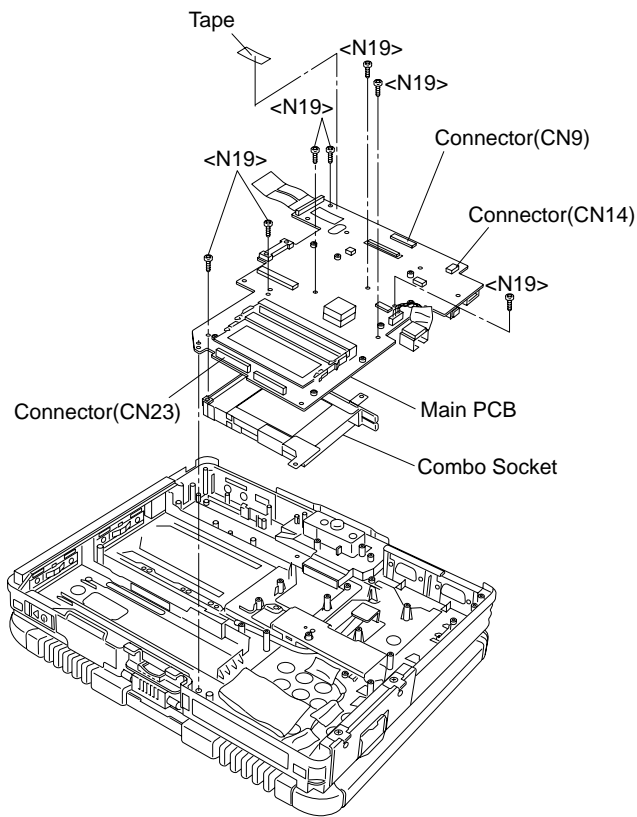

15. Remove the Tape.
16. Disconnect the 3 Cables from the 3 Connectors. (CN9,CN14,CN23)
17. Remove the 7 Screws <N19>, and remove the Main PCB and Combo Socket.

Screws <N3> : DFHE5108ZA
 Screws <N8> : DRSB2+10FKL
 Screws <N9> : DRSB2+5FKL
 Screws <N19> : XSB2+3FNL

9.1.10. Removing the I/O PCB Ass'y

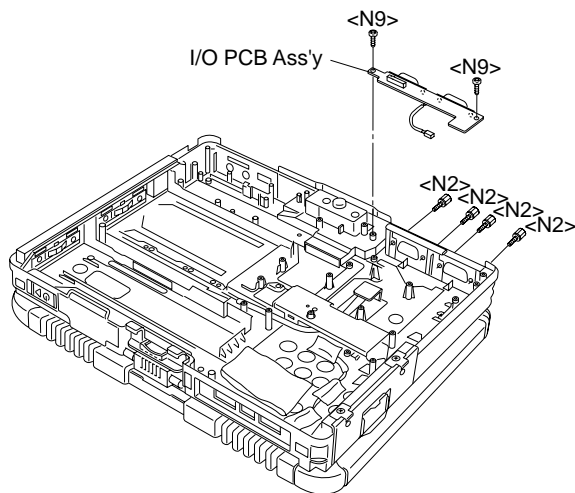

1. Remove the 4 D-SUB Screws <N2>.
2. Remove the 2 Screws <N9>.
3. Remove the I/O PCB Ass'y.

Screws <N2> : DFHE5058ZB
 Screws <N9> : DRSB2+5FKL

9.1.11. Removing the Power SW PCB

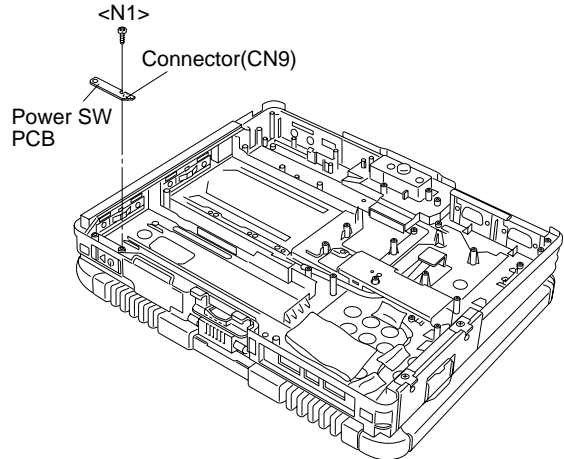

1. Remove the Screw <N1>.
2. Disconnect the Cable from the Connector (CN9).
3. Remove the Power SW PCB.

Screw <N1> : DFHE5025XA

9.1.12. Removing the left LED and right LED PCB

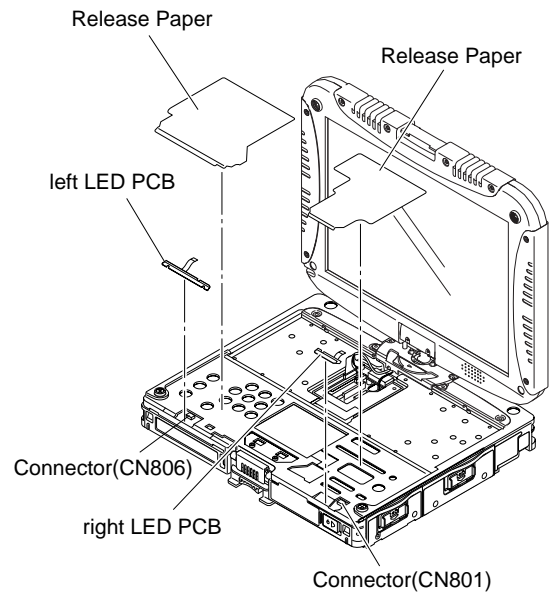

1. Remove the two Release Papers.
2. Disconnect the Cable from the Connector (CN806).
3. Remove the left LED PCB.
4. Disconnect the Cable from the Connector (CN801).
5. Remove the right LED PCB.

9.1.13. Removing Pad PCB and SW PCB

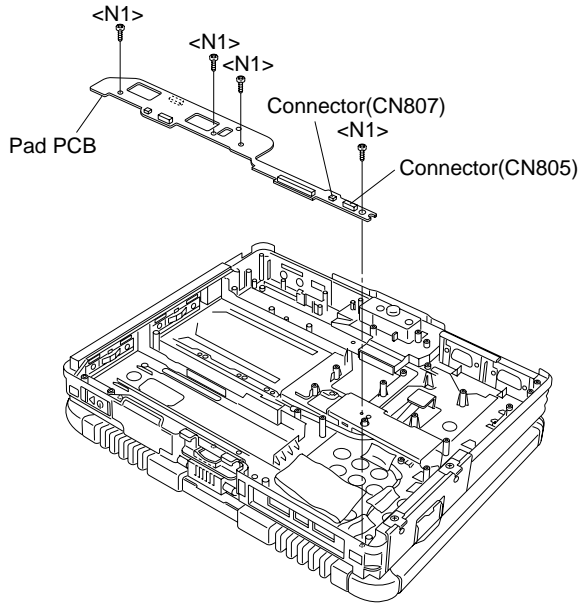

1. Disconnect the 2 Cables from the 2 Connectors (CN805,CN807).
2. Remove the 4 Screws <N1>.
3. Remove the Pad PCB.

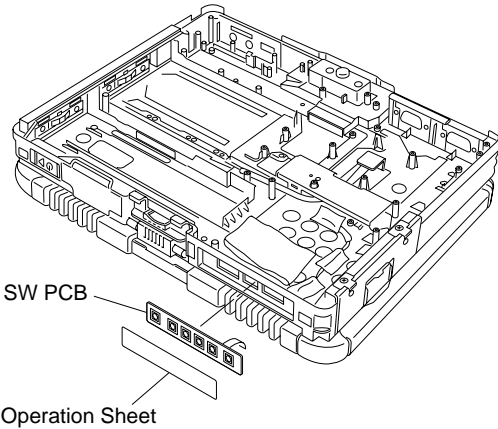

4. Remove the Operation Sheet and the SW PCB.

Screws <N1> : DFHE5025XA

9.1.14. Removing the Display unit

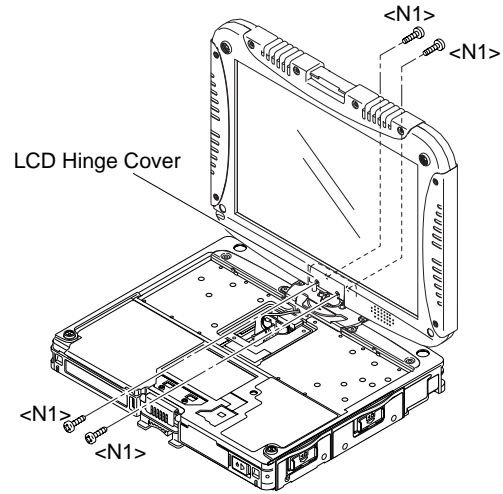

1. Remove the 4 Screws <N1>.
2. Remove the LCD Hinge Cover.

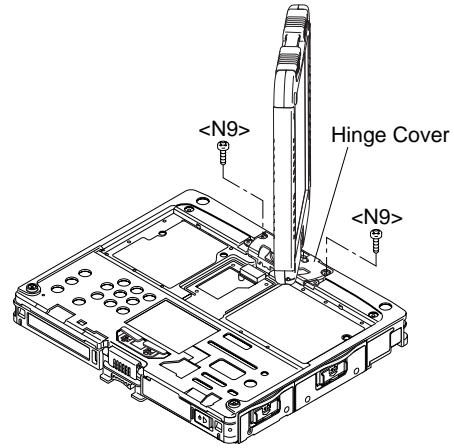

3. Display unit is half-rotated and removes the 2 Screws <N9>.

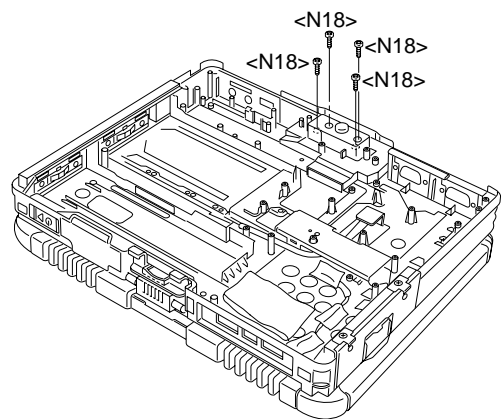

4. Remove the 4 Screws <N18>.
5. Turn the computer over.
6. Remove the Display Unit.

Screws <N1> : DFHE5025XA

Screws <N9> : DRSB2+5FKL

Screws <N18> : DXYN4+J7FNL

9.1.15. Removing the LCD Rear Case

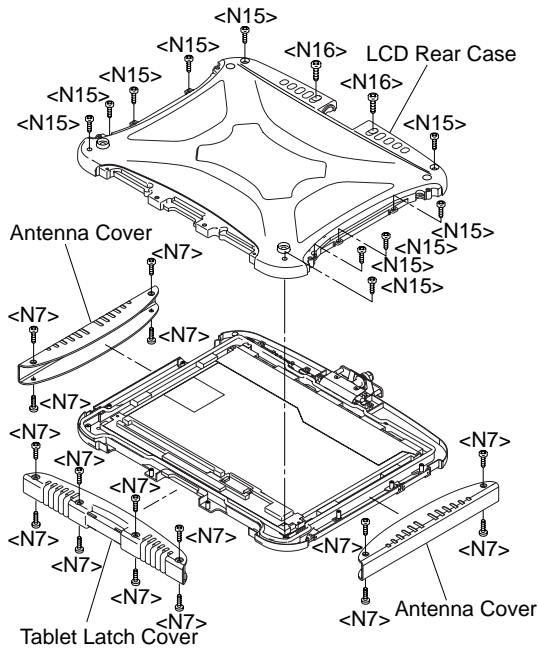

1. Remove the 8 Screws <N7> on the front side of Display unit.
2. Remove the 8 Screws <N7> on the back side of Display unit.
3. Remove 2 Antenna Covers and Tablet Latch Cover.
4. Remove the 10 Screws <N15>.
5. Remove the 2 Screws <N16>.
6. Remove the LCD Rear Case.

Screws <N7> : DRQT26+E5FKL

Screws <N15> : DXYN2+J6FNL

Screws <N16> : DXYN3+J10FNL

9.1.16. Removing the LCD Hinge

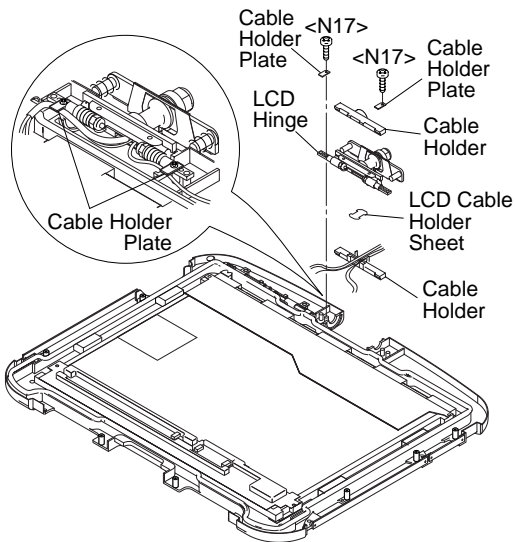

1. Remove the Cable Holder.
2. Remove the 2 Screws <N17>.
3. Remove the Cable Holder Plate and LCD Hinge.

Screws <N17> : DXYN3+J8FNL

9.1.17. Removing Inverter PCB and LCD Unit

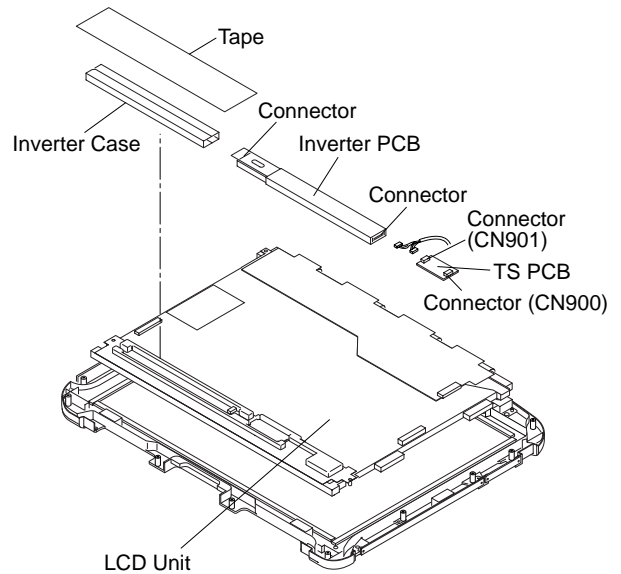

1. Disconnect the 2 Cables from 2 Connectors (CN1,CN2).
2. Remove the Inverter Case and Inverter PCB.
3. Disconnect the 2 Cable from 2 connector (CN900,CN901).
4. Remove the TS PS2 PCB, then remove the LCD unit.

9.1.18. Removing WWAN Main Antenna PCB, LAN-Main BT Antenna PCB, LAN AUX Antenna PCB and WWAN AUX Antenna PCB

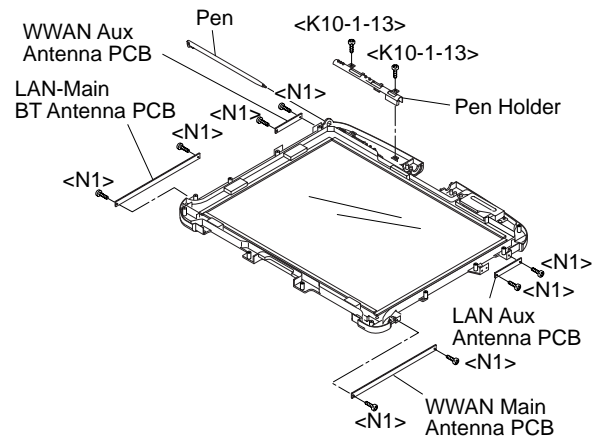

1. Remove the 2 Screws <N1>.
2. Remove the WWAN Main Antenna PCB.
3. Remove the 2 Screws <N1>.
4. Remove the LAN-Main BT Antenna PCB.
5. Remove the 2 Screws <N1>.
6. Remove the LAN AUX Antenna PCB.
7. Remove the 2 Screws <N1>.
8. Remove the WWAN AUX Antenna PCB.
9. Remove the Pen
10. Remove the two Screws <N6>.
11. Remove the Pen Holder.

Screws <N1> : DFHE5025XA

Screws <N6> : DRHM5025YA

9.1.19. Removing the Each Cover

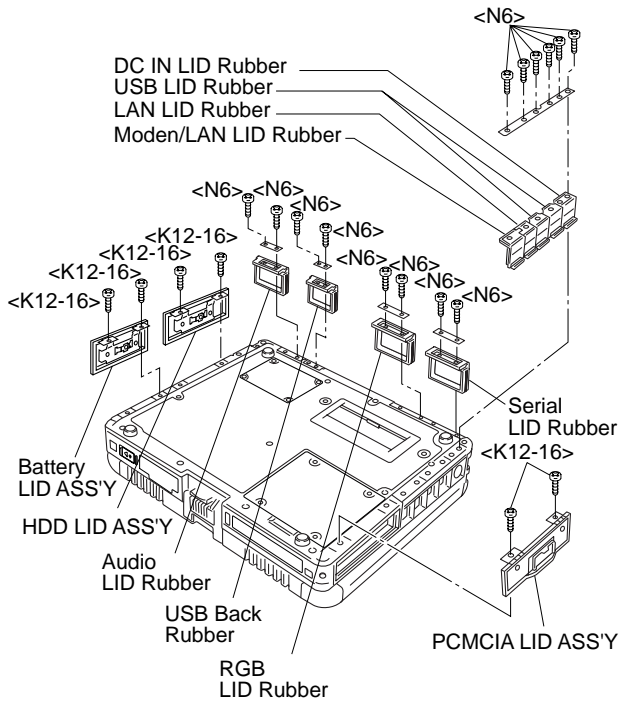

1. Remove the 14 Screws <N6>.
2. Remove the Modem/LAN LID Rubber, LAN LID Rubber, USB LID Rubber, DC IN LID Rubber, Serial LID Rubber, RGB LID Rubber, Audio LID Rubber and USB Back Rubber.
3. Remove the Rear Cabinet.
(Refer to 7.1.5 Removing the Rear Cabinet)
4. Remove the 6 Screws <K12-16>.
5. Remove the Battery LID ASS'Y, HDD LID Ass'y and PCMCIA LID Ass'y.

Screws <K12-16> : DRQT26+D3FKL

Screws <N6> : DRHM5025YA

9.2. Reassembly Instructions

9.2.1. Attention when CF-19 series is repaired

- ▮ Please execute writing BIOS ID when you exchange the Main Board.
- ▮ Parts (Sheet and rubber) etc. related various the Conductive Cloth and Heat Spreader cannot be recycled. Use new parts.

9.2.2. Setting up the Inverter Ass'y and LCD UNIT

1. Set the LCD UNIT to the LCD Front Cabinet/TS Panel.
2. Set the TS PCB on the LCD Back Damper, and connect the 2 Cables to the Connectors (CN900 and CN901).
3. Set the Inverter PCB to the LCD Back Damper, and connect the 2 Cables to the Connectors.

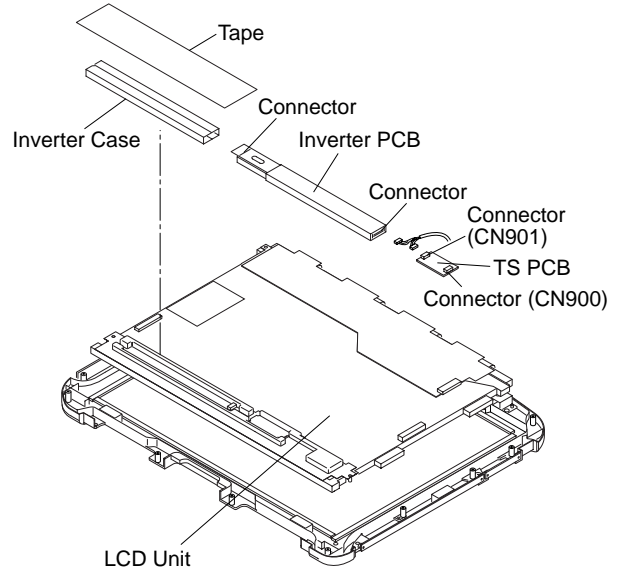

■ Assembly of LCD Back Damper (Applicable Model : Touch Screen Model)

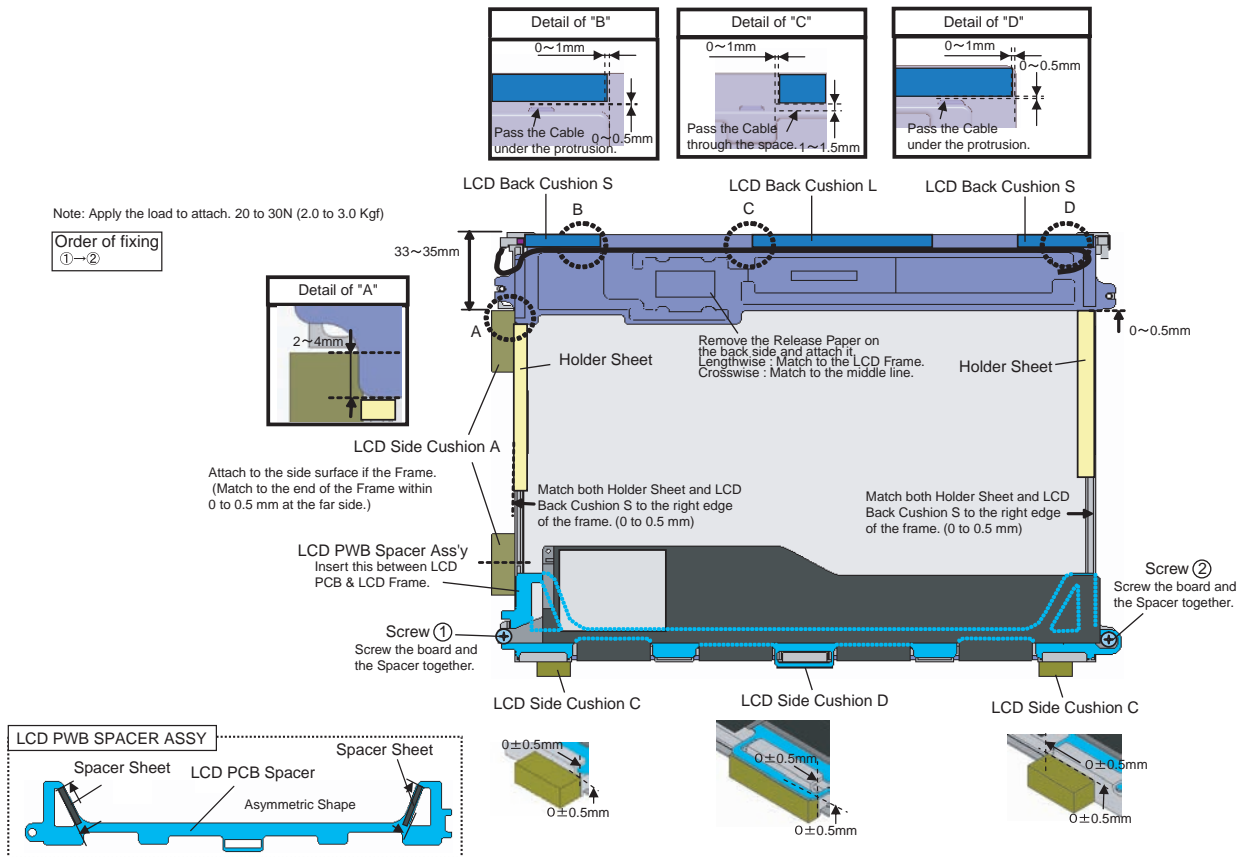

■ Assembly of LCD Back Damper (Application Model : Digitizer Model)

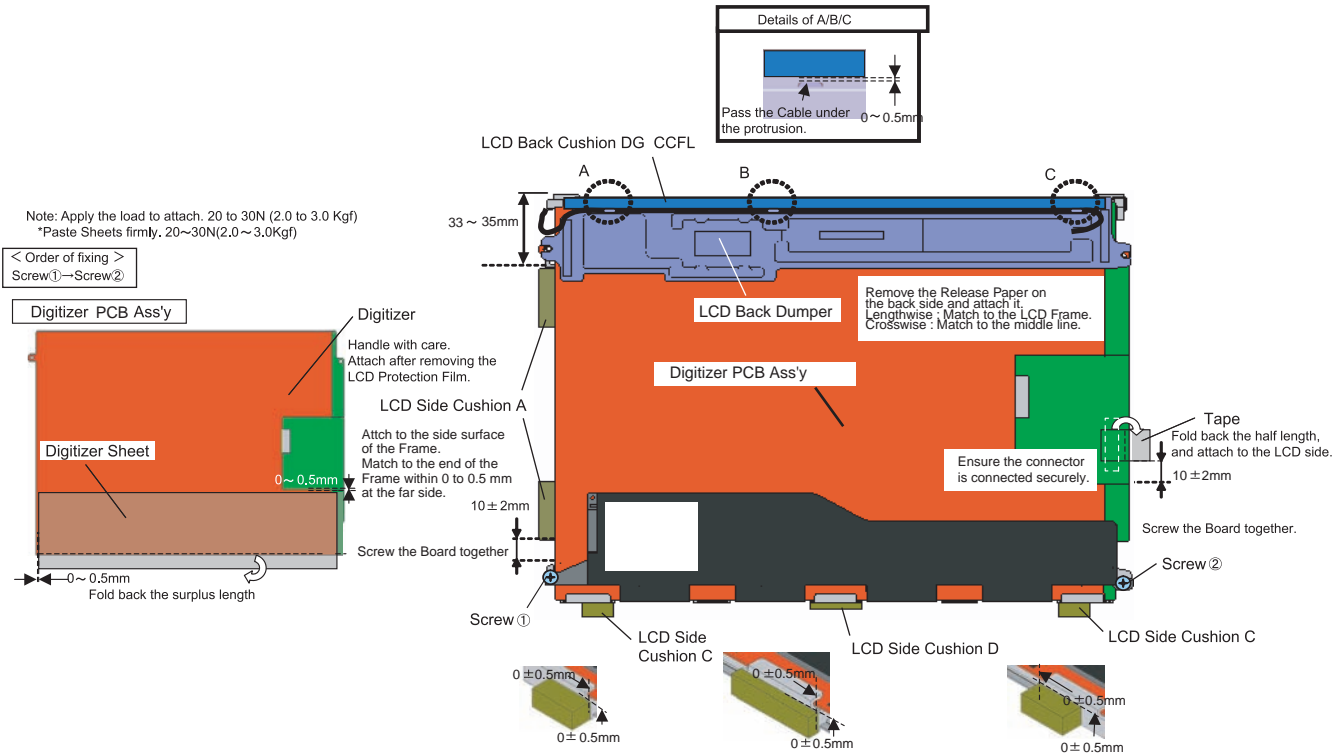

■ Assembly of Inverter PCB

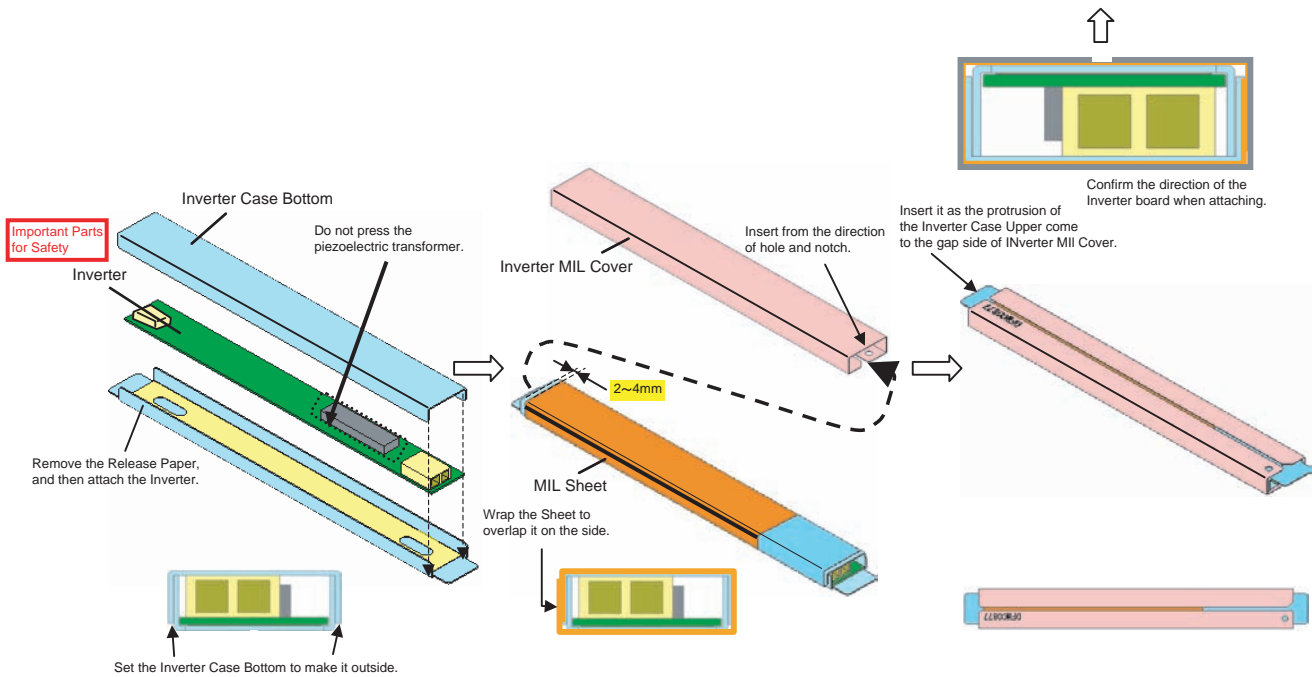

■ Assembly of Inverter PCB (Applicable Model : Touch Screen Model)

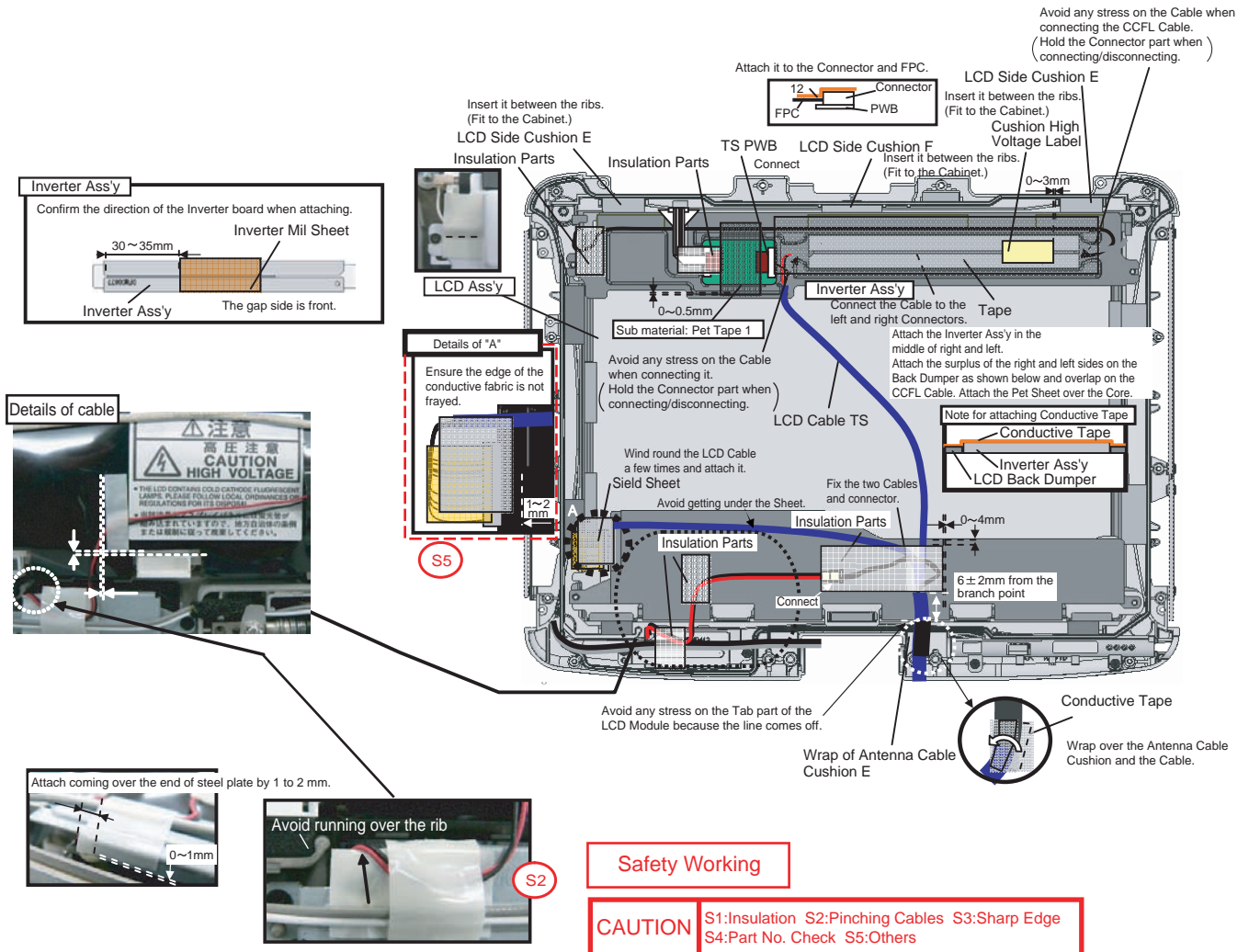

■ Assembly of Inverter PCB (Application Model : Digitizer Model)

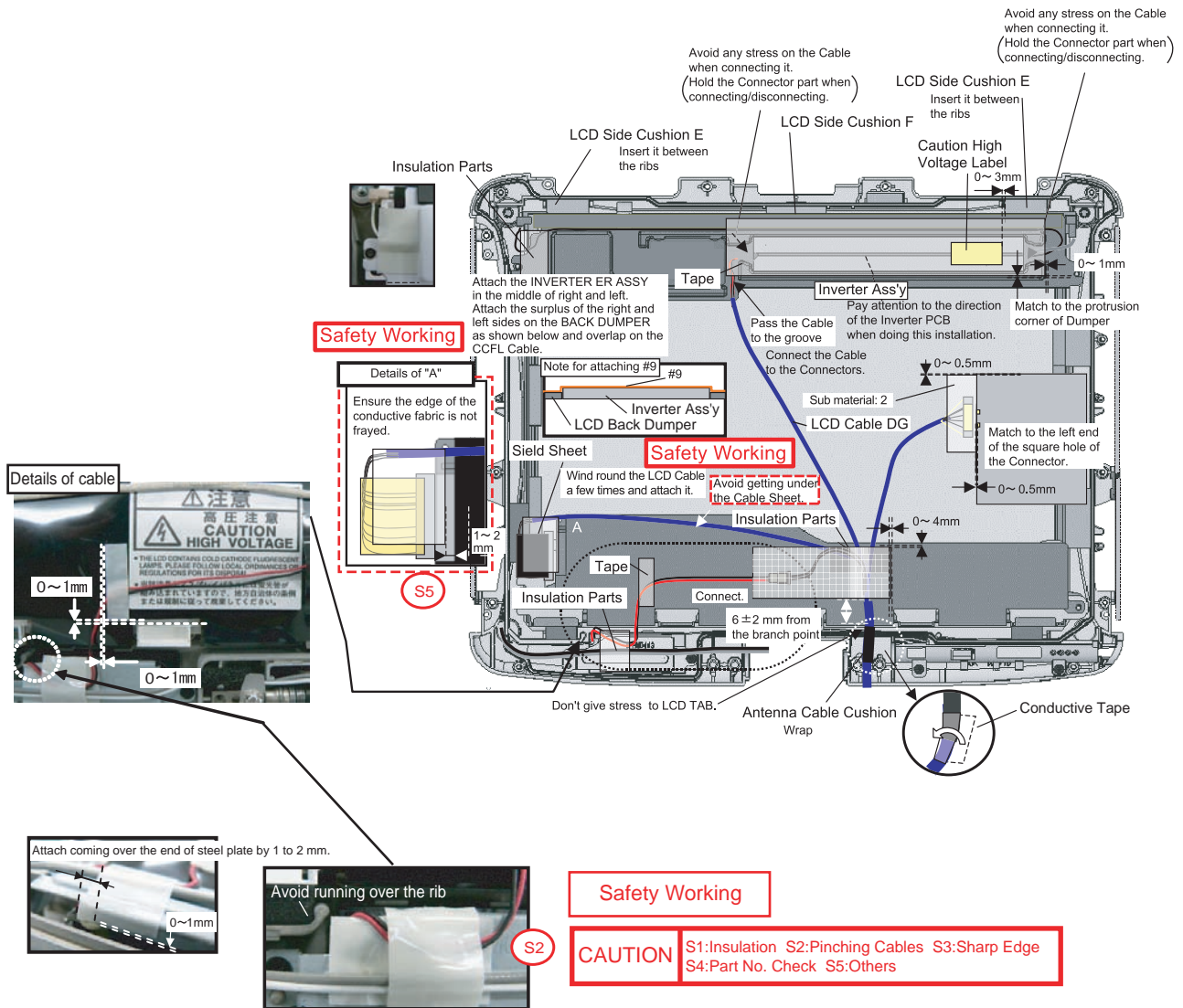

■ Assembly of Touch Screen (Applicable Model : Touch Screen Model)

(Note)
Apply the load 20 to 30N (2.0 to 3.0 Kgf) to the Cushions.

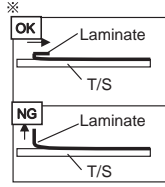

Attach it to the front side.
(Using the jig)
Dimensional tolerance: ± 0.2

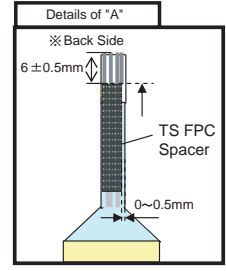
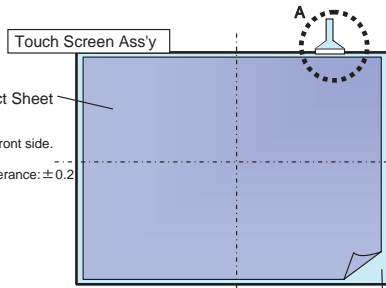

Match to the wall of the Cabinet. 0 to 0.5 mm

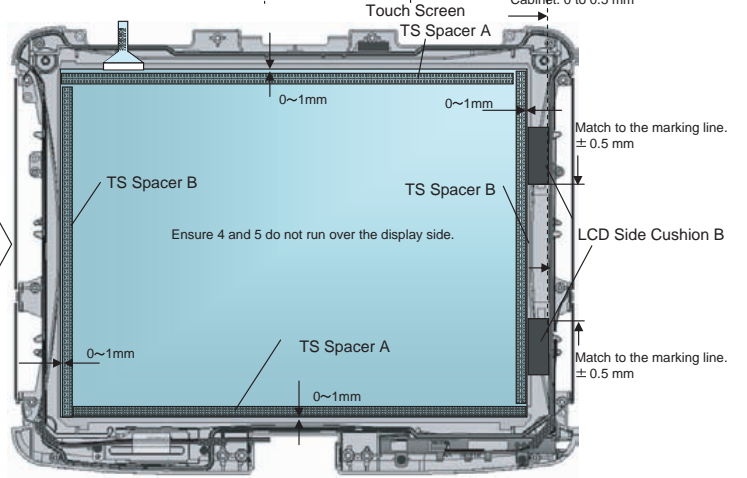
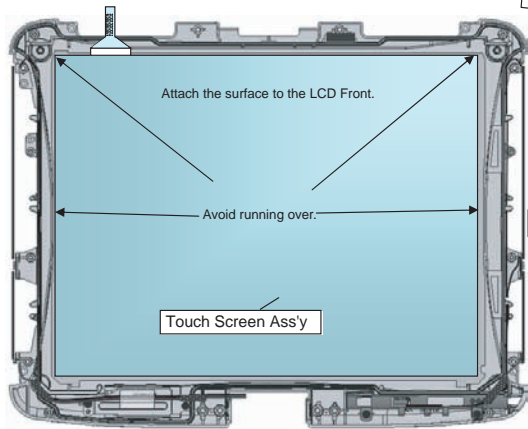

■ Assembly of Glass (Applicable Model : Digitizer Model)

(Note)
Apply the load 20 to 30N (2.0 to 3.0 Kgf) to the Cushions.

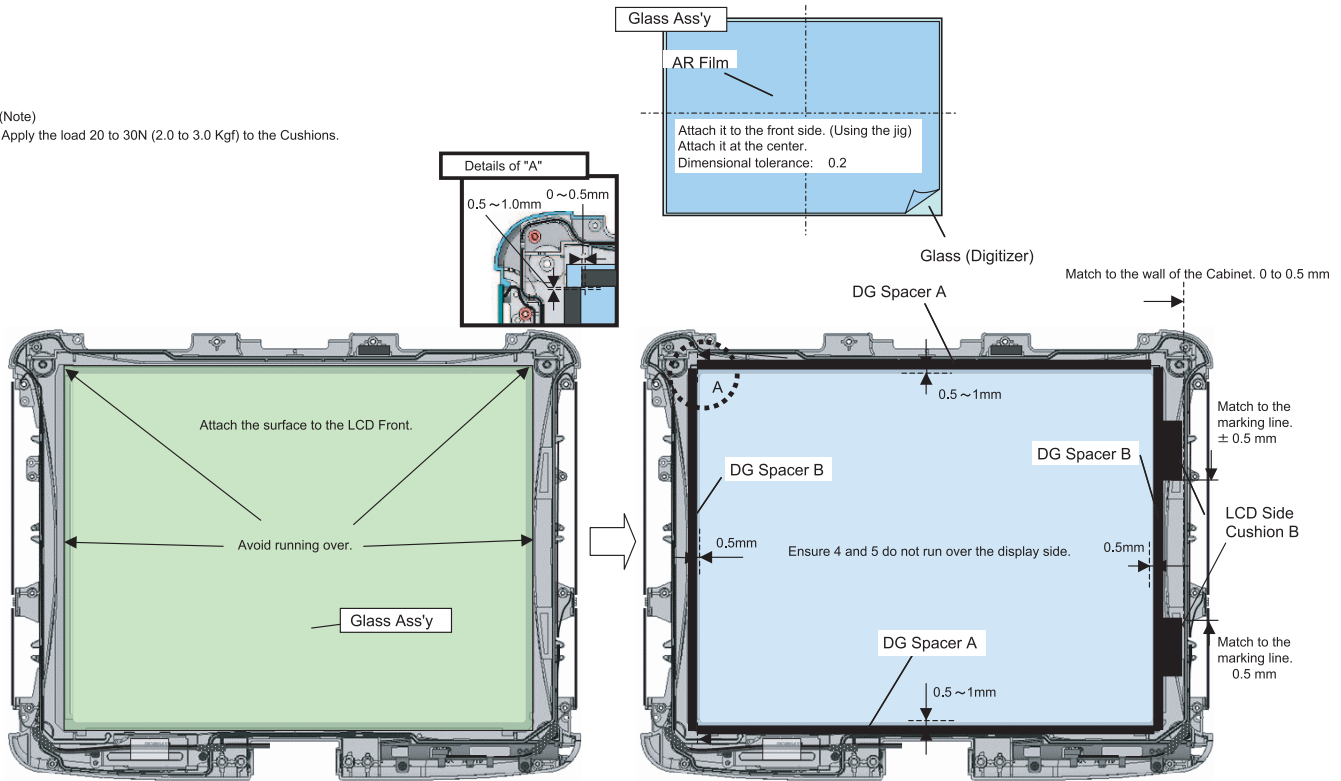

9.2.3. Assembling the WWAN Main Antenna PCB, LAN-Main BT Antenna PCB, LAN AUX Antenna PCB, WWAN AUX Antenna PCB and Pen holder

1. Fix the Pen Holder using the 2 Screws. <K10-1-13>
2. Attach the Pen.
3. Fix the WWAN AUX Antenna PCB using the 2 Screws. <N1>
4. Fix the LAN AUX Antenna PCB using the 2 Screws. <N1>
5. Fix the LAN-Main BT Antenna PCB using the 2 Screws. <N1>
6. Fix the WWAN Main Antenna PCB using the 2 Screws. <N1>

Screws <N1> : DFHE5025XA
Screws <K10-1-13> : DRHM5025YAT

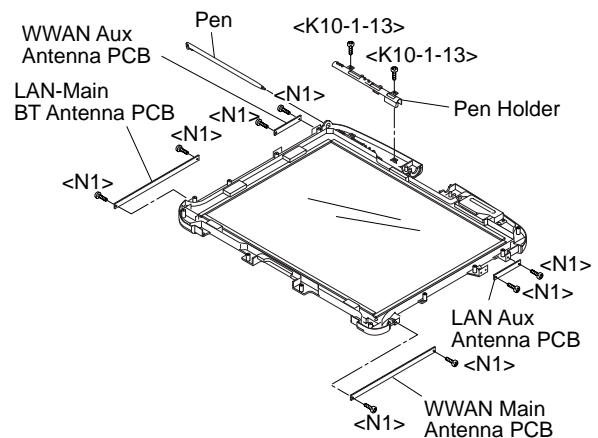

Line Processing of Antenna Cable

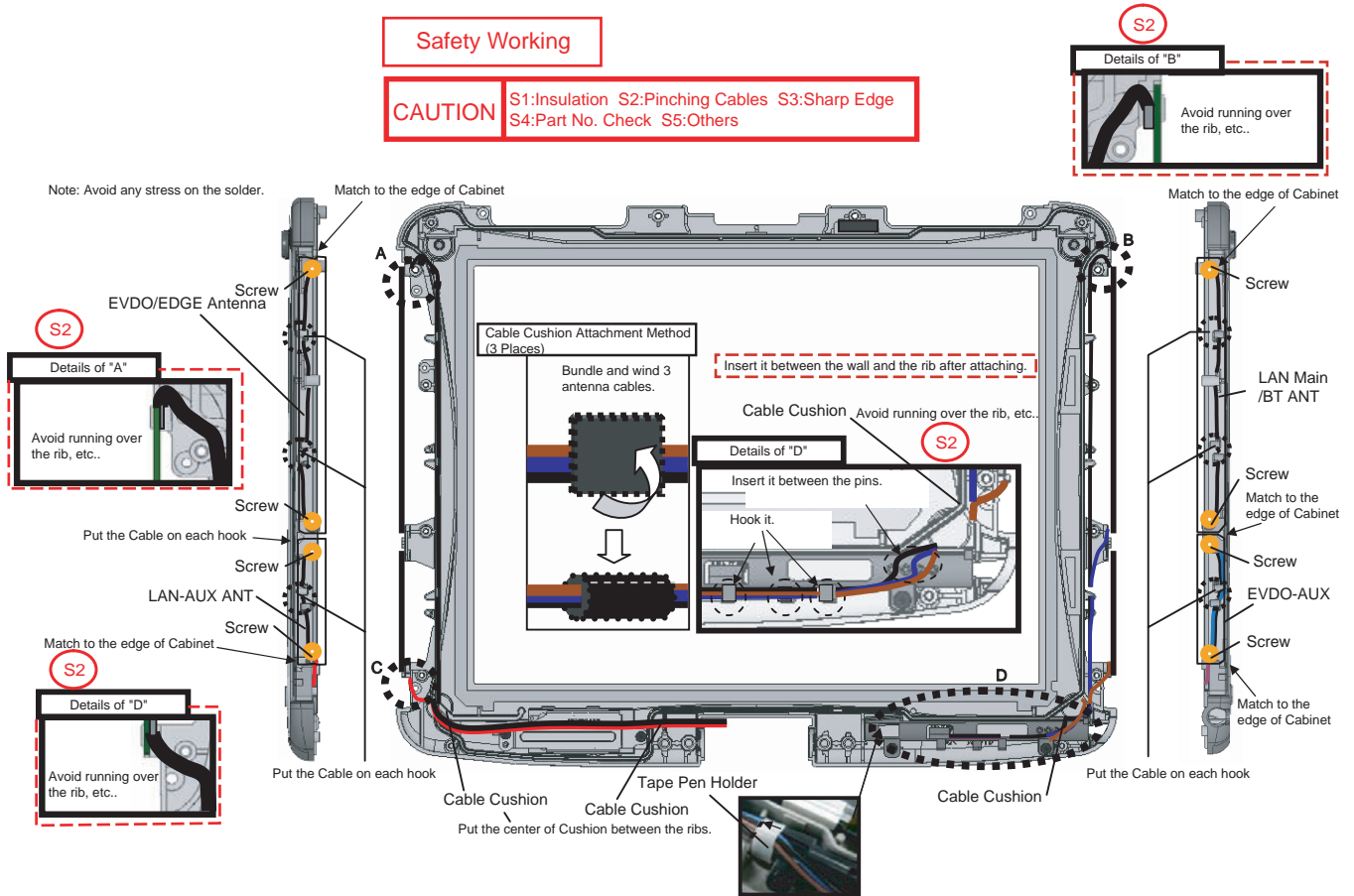

9.2.4. Setting up the LCD Hinge

1. Wind the Cable coming out of the LCD Unit counterclockwise to the LCD Hinge.
2. Set the Lock Plate and the Hinge Top Cover, and rotate the LCD Hinge to turn the Display Unit to front
3. Put the LCD Cable and the Antenna Cable in the Cable Holder.
4. Fit another Cable Holder and clamp the Cable Holders in the LCD Hinge.
5. Fix the LCD Hinge using the 2 Screws <N17> and the 2 Cable Holder Plates.

Screws <N17 > : DXYN3+J8FNL

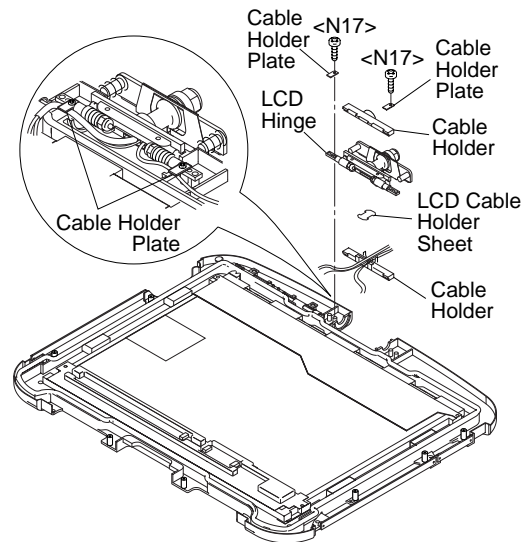

■ Assembly of LCD Hinge

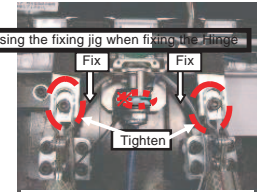
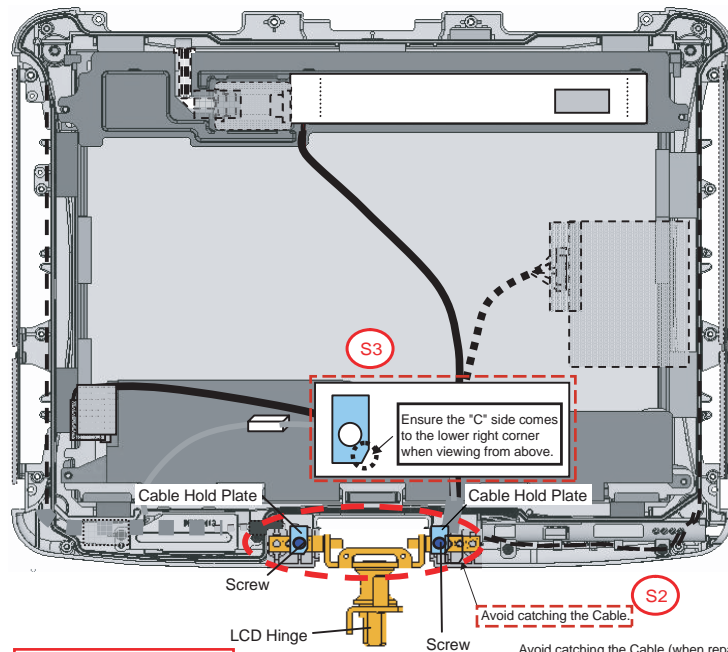
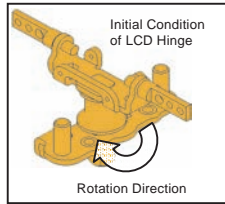

If you arrange the Cable in the ※ area, you do not need to use the fixing jig.

Safety Working

CAUTION S1:Insulation S2:Pinching Cables S3:Sharp Edge
S4:Part No. Check S5:Others

Avoid catching the Cable (when repairing or when not using the jig).
Temporarily fix the both sides ("A") of the Hinge using the Screw, and fix the Cable Hold Plate.
After fixing the Cable Hold Plate, remove the screws from the both sides ("A").

Line Processing of Antenna Cable and LCD Cable

Safety Working

CAUTION S1:Insulation S2:Pinching Cables S3:Sharp Edge
S4:Part No. Check S5:Others

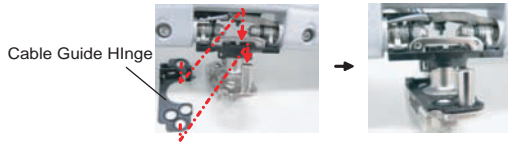
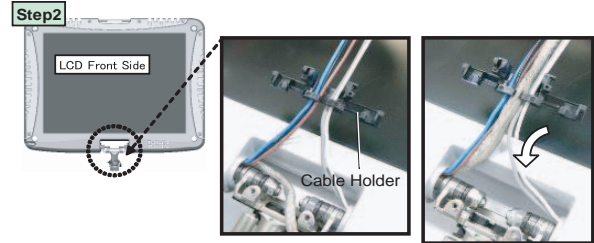
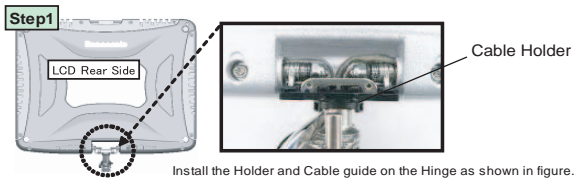

<CAUTION>-Position of the Antenna Cables
•Right side of LCD Cable:White/Gray
•Left side of LCD Cable:Blue/Black/Brown

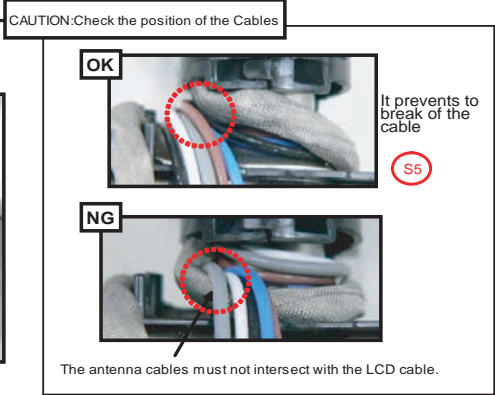
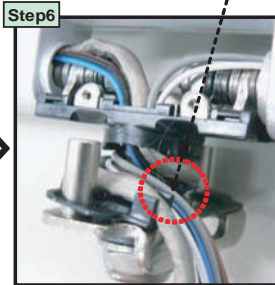
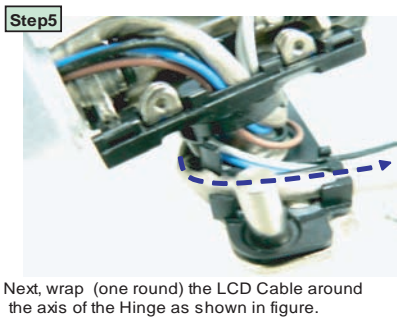
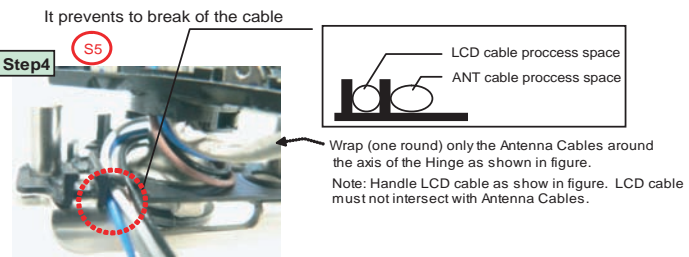
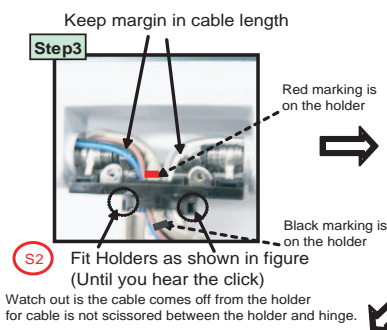

9.2.5. Assembling the Antenna Cover, the Tablet Latch Cover and the LCD Rear Case

1. Fix the LCD Rear Case using the 10 Screws <N15> and the 2 Screws. <N16>
2. Attach the Antenna Covers and the Tablet Latch Cover to the Display Unit.
3. Tighten the 8 Screws <N7> on the back of the Display Unit.
4. Turn the Display Unit over, and tighten the 8 Screws. <N7>

Screws <N7> : DRQT26+E5FKL

Screws <N15> : DXYN2+J6FNL

Screws <N16> : DXYN3+J10FNL

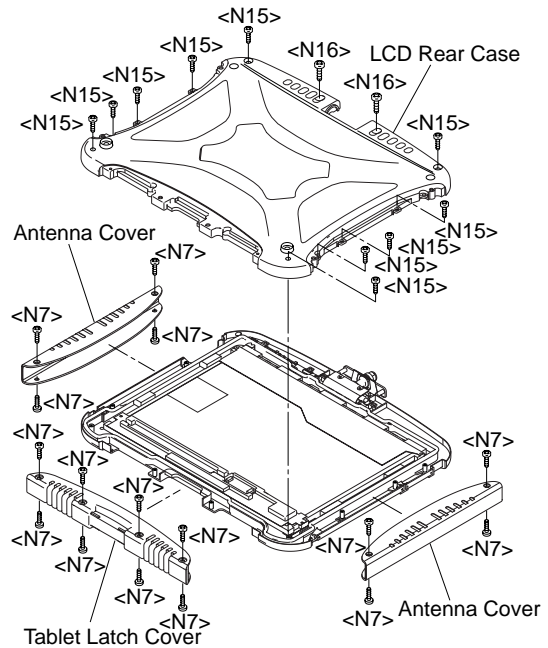

■ Assembly of LCD Front Case

※ Do not use if the protrusion such as painting lump exists around D5.
(Due to affect the Touch Screen operations.)

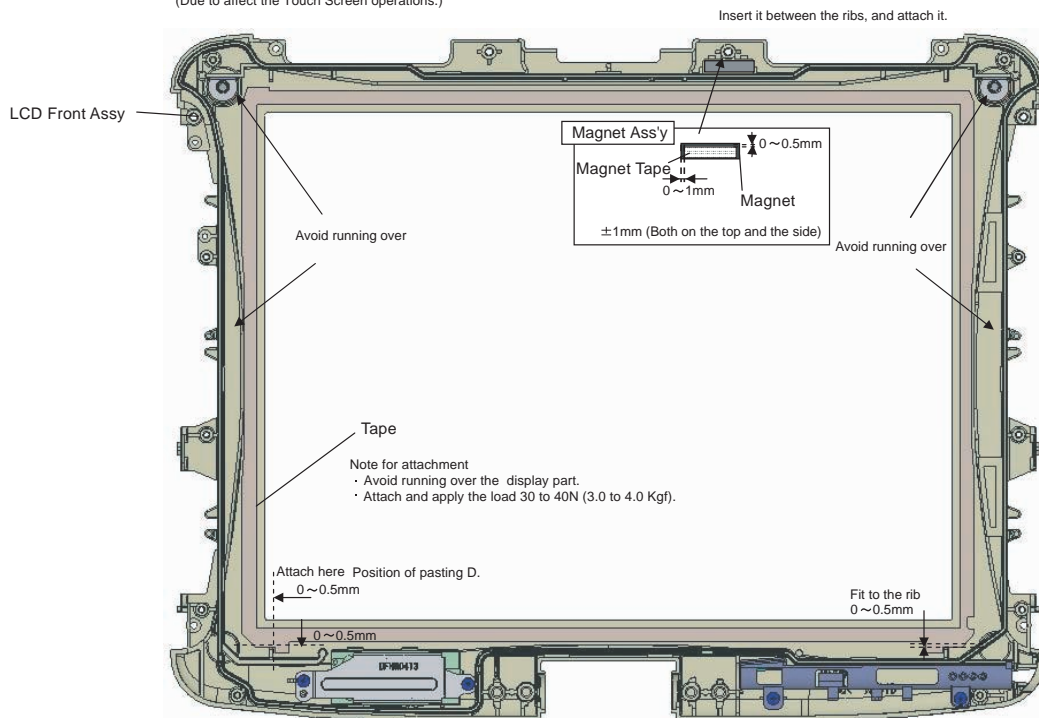

■ Assembly of LCD Rear Case (Applicable Model : Touch Screen Model)

- (Note)
- Arrow without specified measurement: 0 to 0.5 mm
 - Allowable right/left displacement of the Cushion: max. 0.5 mm
 - Attach and apply the load 30 to 40N (3.0 to 4.0 Kgf).

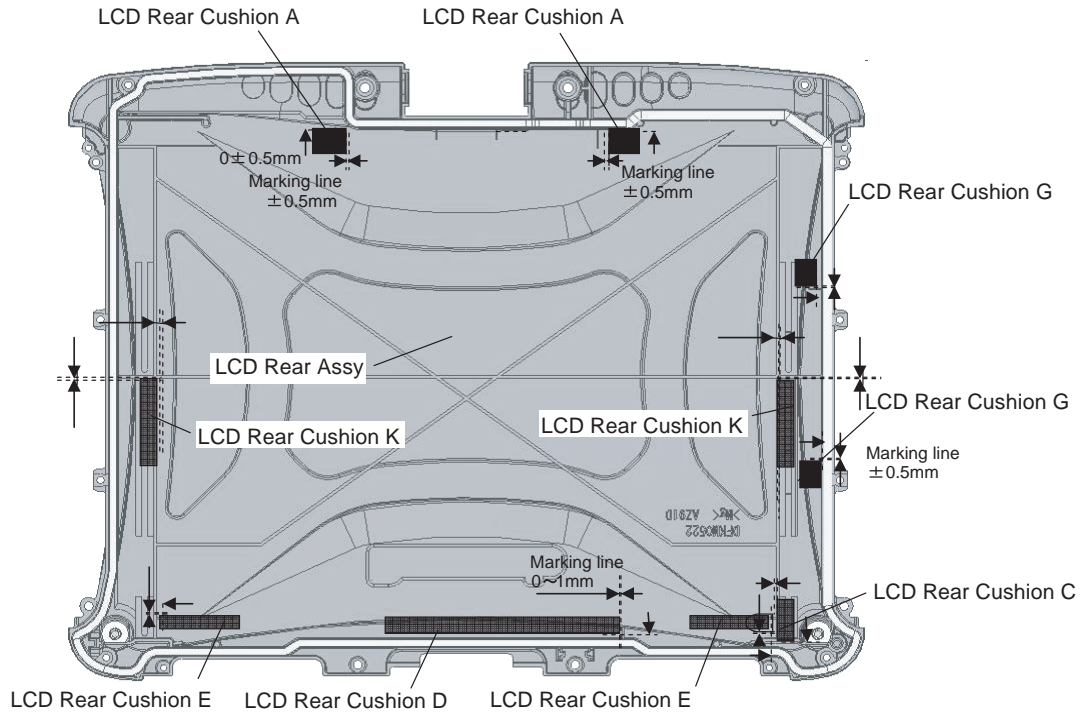

■ Assembly of LCD Rear Case (Applicable Model : Digitizer Model)

- (Note)
- Arrow without specified measurement: 0 to 0.5 mm
 - Allowable right/left displacement of the Cushion: max. 0.5 mm
 - Attach and apply the load 30 to 40N (3.0 to 4.0 Kgf).

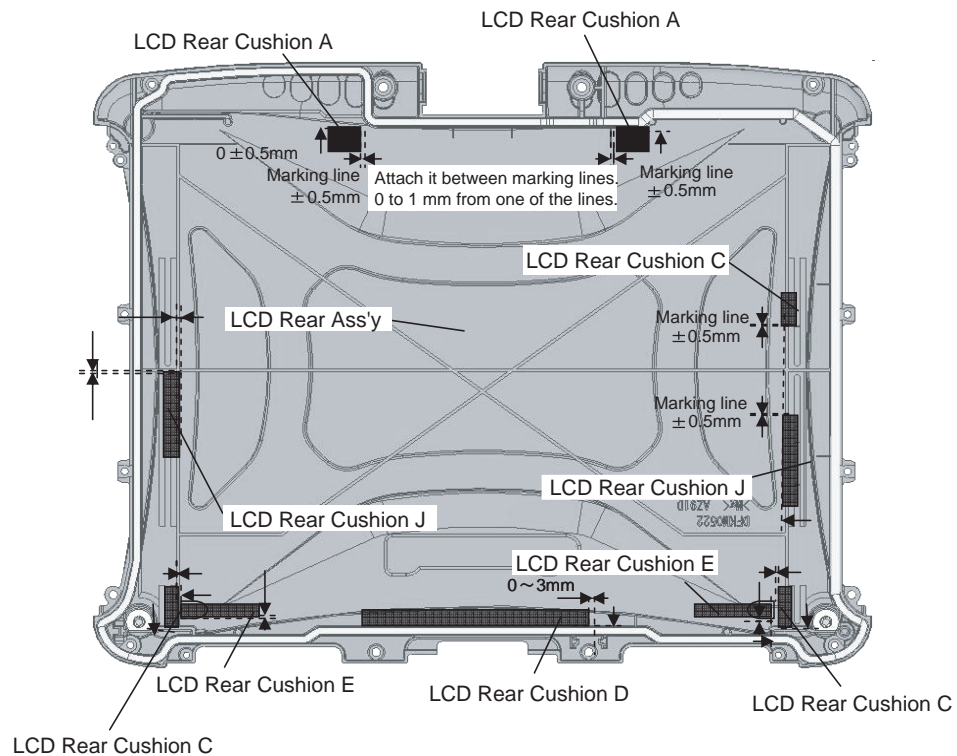

■ Assembly of Tablet Latch Cover and Antenna Cover

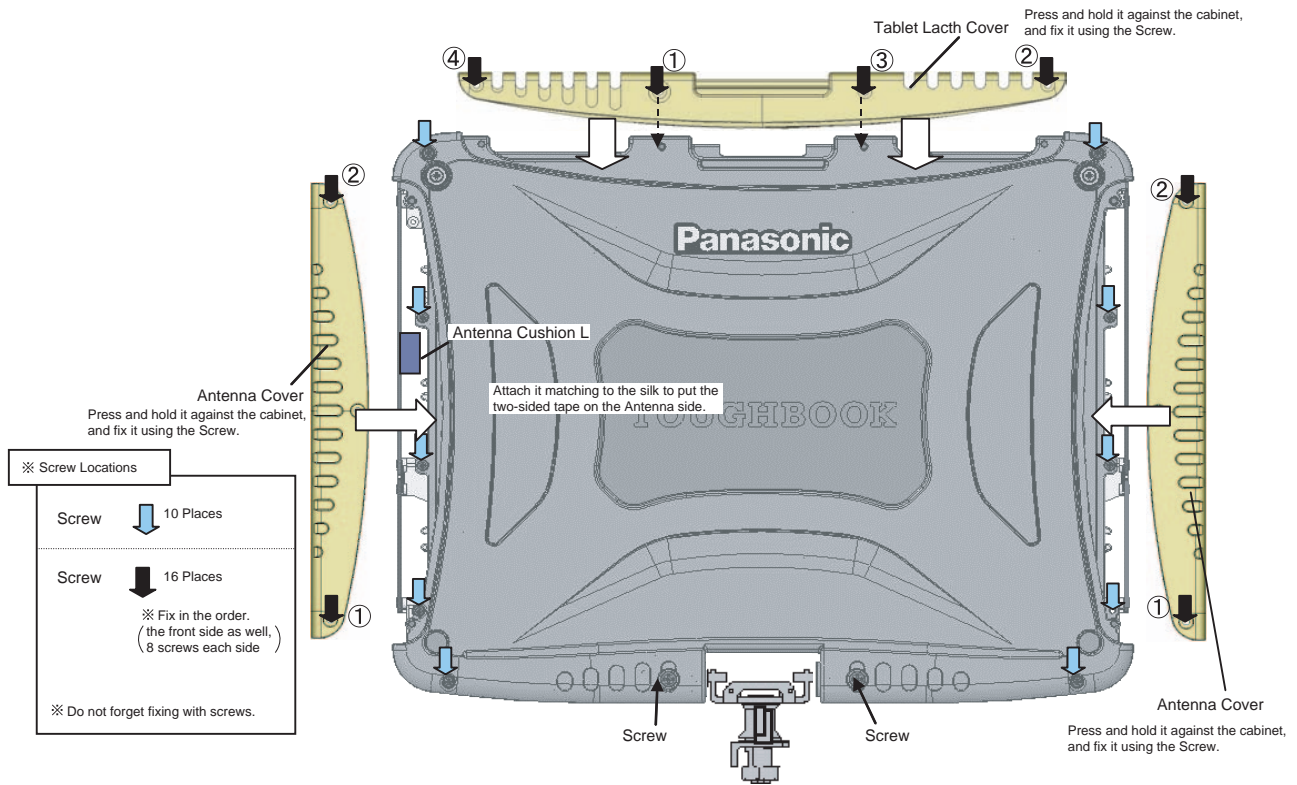

9.2.6. Setting the Display Unit

1. Fix the Display Unit using the 2 Screws <N9>.
2. Close the Display Unit and turn the computer over, then fix the Display Unit using the 4 Screws <N18>.

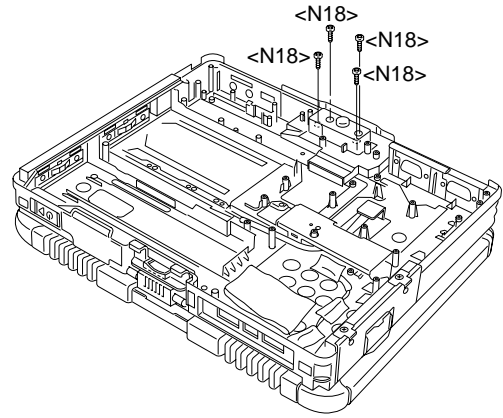

3. Turn the computer over and fix the LCD Hinge Cover using the 2 Screws <N1>.

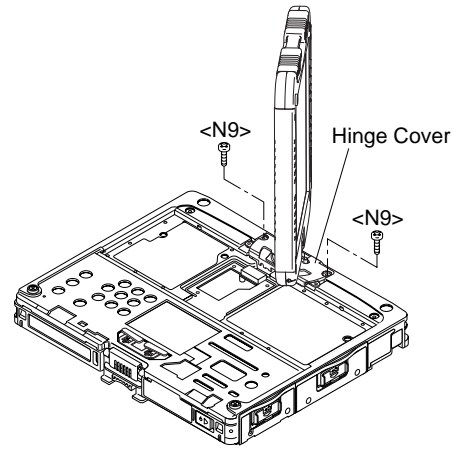

4. Open the Display Unit and fix the LCD Hinge Cover using the 2 Screws <N1>.

Screws <N1> : DFHE5025XA
Screws <N9> : DRSB2+5FKL
Screws <N18> : XYN4+J7FNL

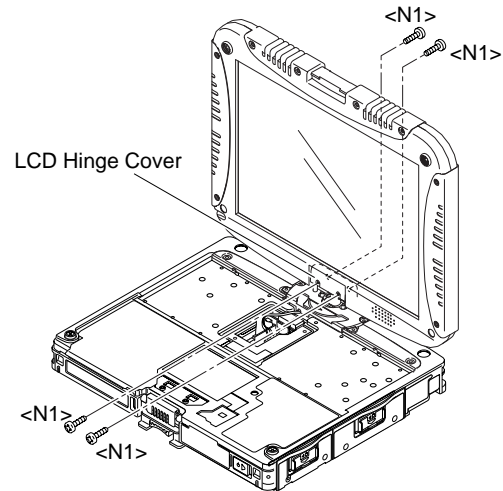

■ Assembly of Display Unit

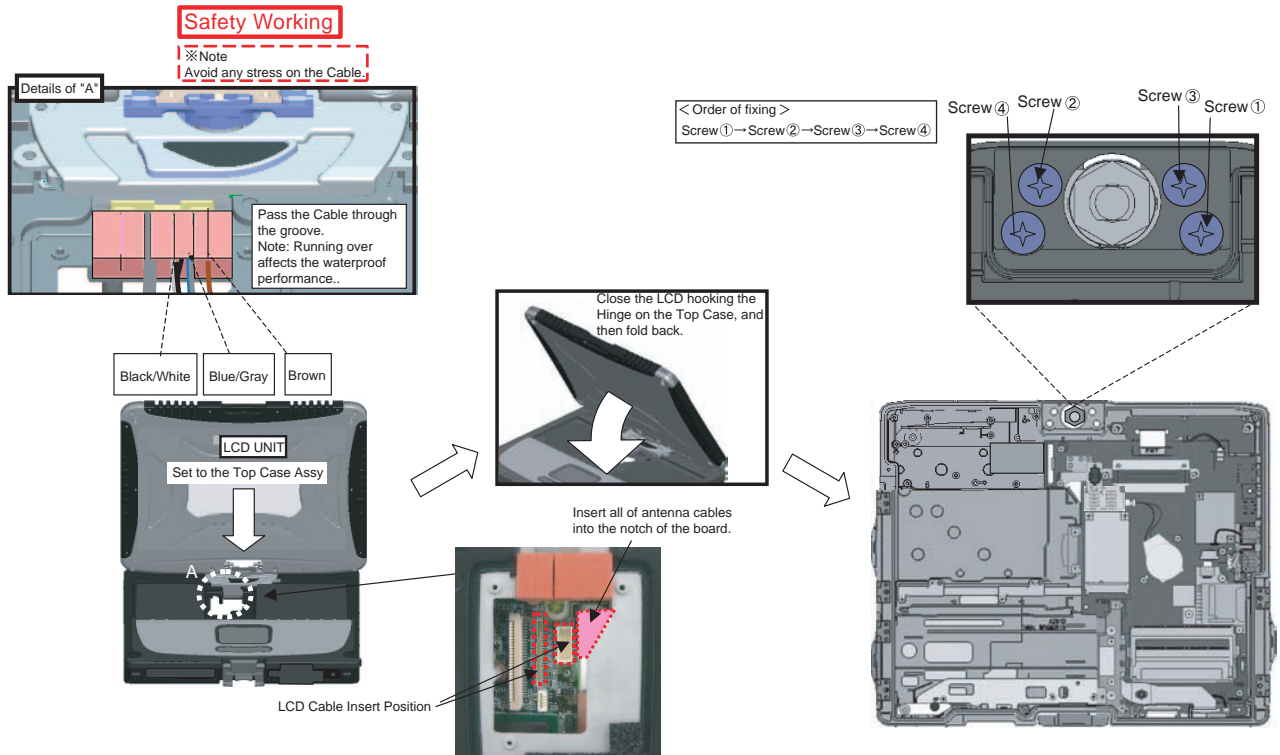

9.2.7. Setting the Pad PCB and SW PCB

1. Attach both the SW PCB and the Operation Sheet to the Cabinet.

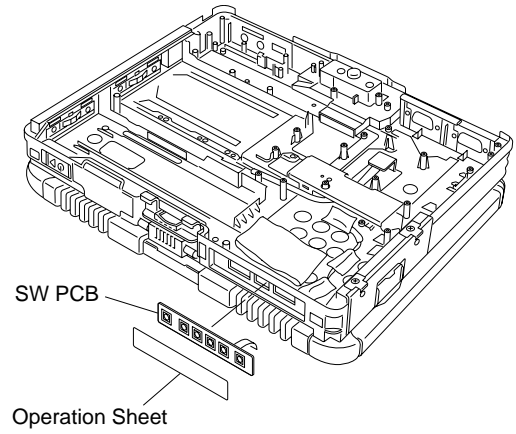

2. Connect the 3 Cables to the 3 Connectors.
(CN800,CN805,CN807)
3. Fix the Pad PCB using the 4 Screws. <N1>

Note:

Tighten the Screws in the numbered order (No1 to No4).

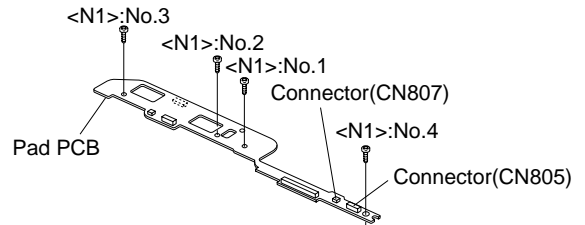

Screws <N1> : DFHE5025XA

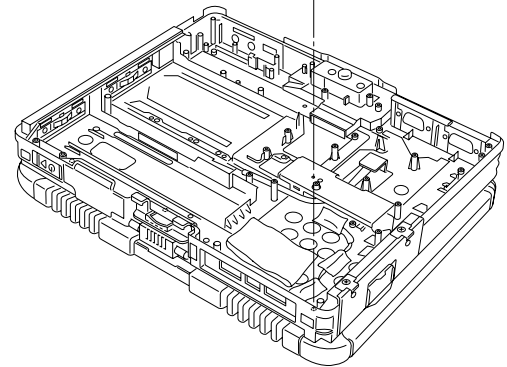

■ Assembly of the Pad PCB and SW PCB

(Note) • Arrow without specified measurement: 0 to 0.5 mm

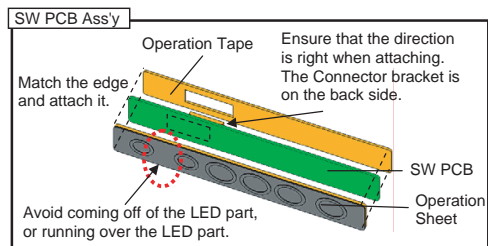
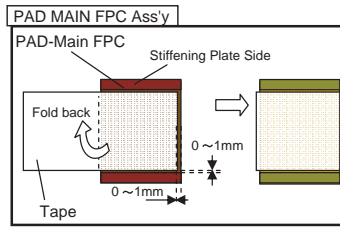
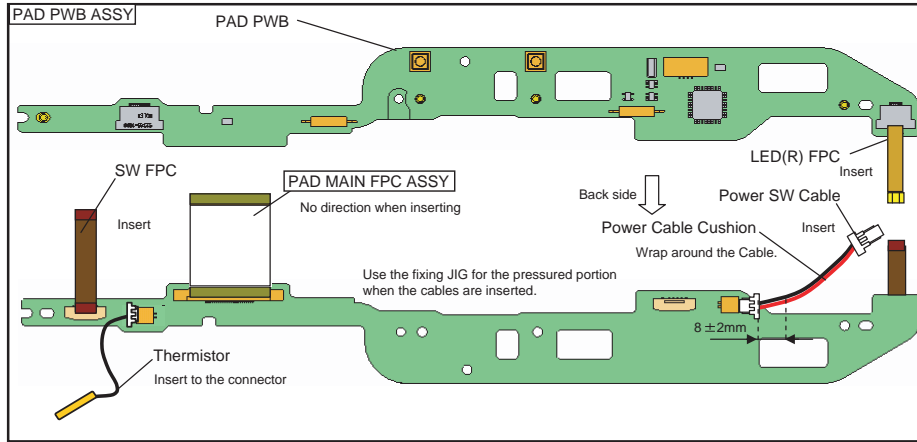

■ Putting of the TP Bottom Tape

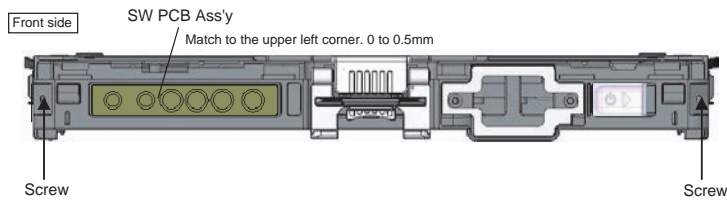

9.2.8. Setting the left LED PCB and right LED PCB

1. Connect the Cable to the Connector. (CN806)
2. Fix the left LED PCB.
3. Connect the Cable to the Connector. (CN801)
4. Fix the right LED PCB.
5. Attach the two Release Papers.
6. Attach the Palm Rest Ass'y.

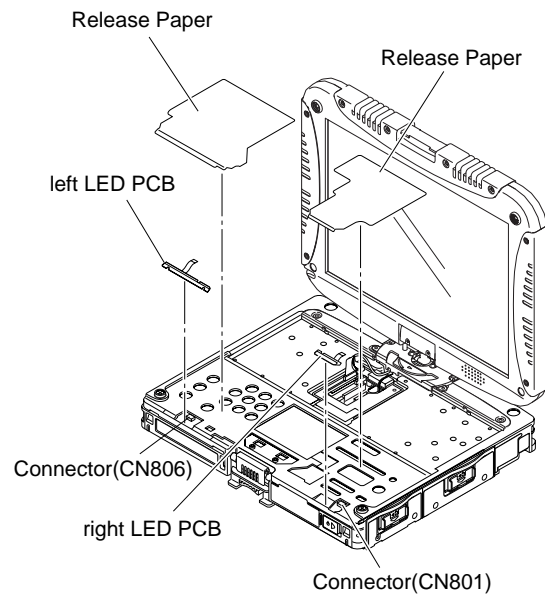

■ Assembly of the left LED PCB and right LED PCB

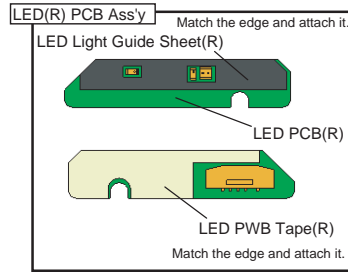
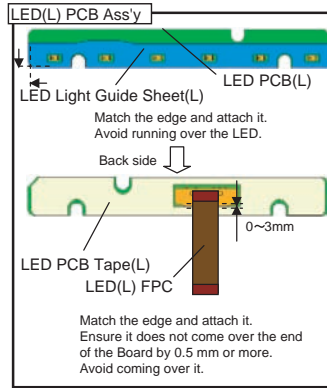

9.2.9. Setting the Power SW PCB

1. Connect the Cable to the Connector. (CN9)
2. Fix the Power SW PCB using the Screw. <N1>

Screws <N1> : DFHE5025XA

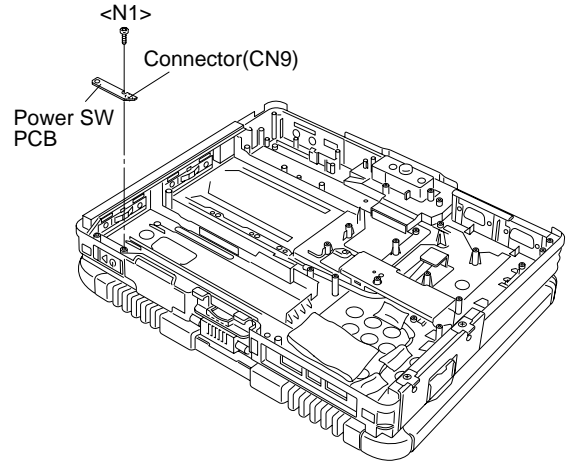

■ Assembly of the Power SW PCB

(Note) Arrow without specified measurement: 0 to 0.5 mm

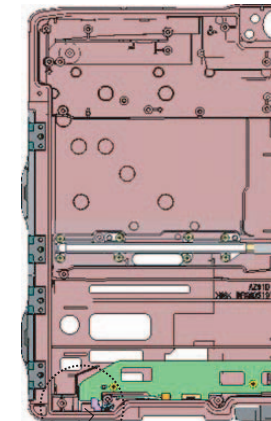
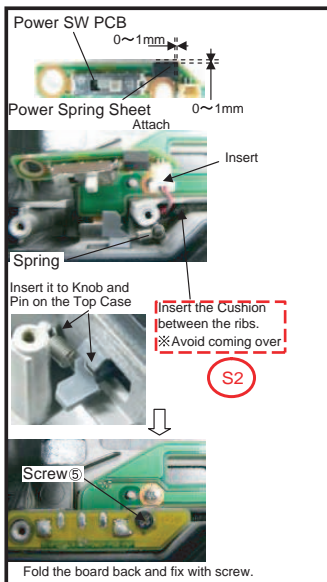

Safety Working

CAUTION

S1:Insulation S2:Pinching Cables S3:Sharp Edge
S4:Part No. Check S5:Others

9.2.10. Setting the I/O PCB Ass'y

1. Fix the I/O PCB using the 2 Screws. <N9>
2. Fix the I/O PCB using the 4 Screws. <N2>

Screws<N2> : DFHE5058ZB

Screws<N9> : DRSB2+5FKL

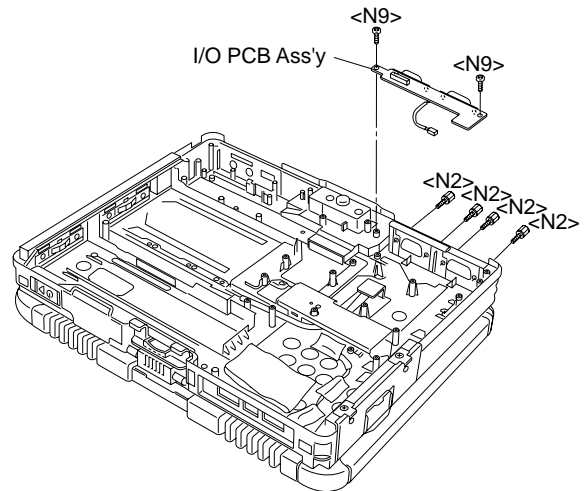

9.2.11. Setting the Main PCB, Wireless Module, SD PCB, DU PCB, Antenna PCB and Modem PCB

1. Fix the Main PCB using the 7 Screws <N19>.
2. Connect the 3 Cables to the 3 Connectors.
(CN9,CN14,CN23)
3. Attach the Tape.

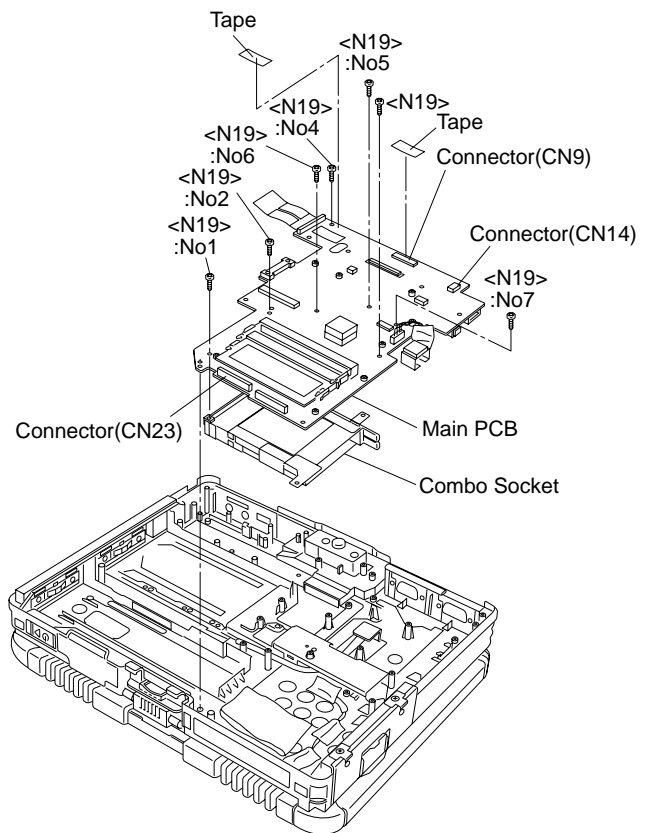

4. Fix the Modem PCB using the 2 Screws <N19>.
5. Fix the Wireless Module using the 2 Screws <N19>.
6. Fix the DIMM Holder using the 2 Screws <N19>.
7. Attach the Cable to the Connector (CN3) and attach the Coin Battery.

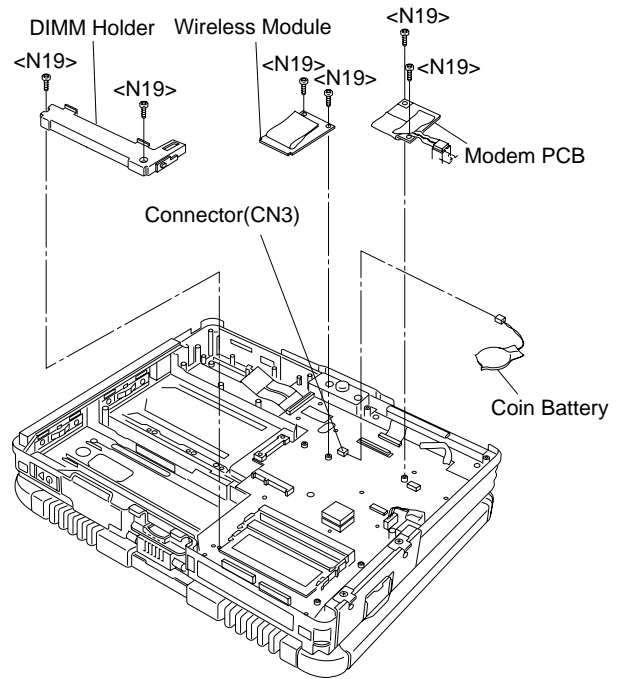

8. Fix the SD PCB Ass'y using the 3 Screws <N19>.
9. Attach the Cable to the Connector (CN21).
10. Hook the Flex Cable on the DIMM Holder, and turn 90 degrees.
11. Fix the BAT FPC Ass'y using the 2 Screws <N9>.
12. Connect the cable to the Connector. (CN15)
13. Fix the HDD Connector Guide using the 2 Screws <N8>.

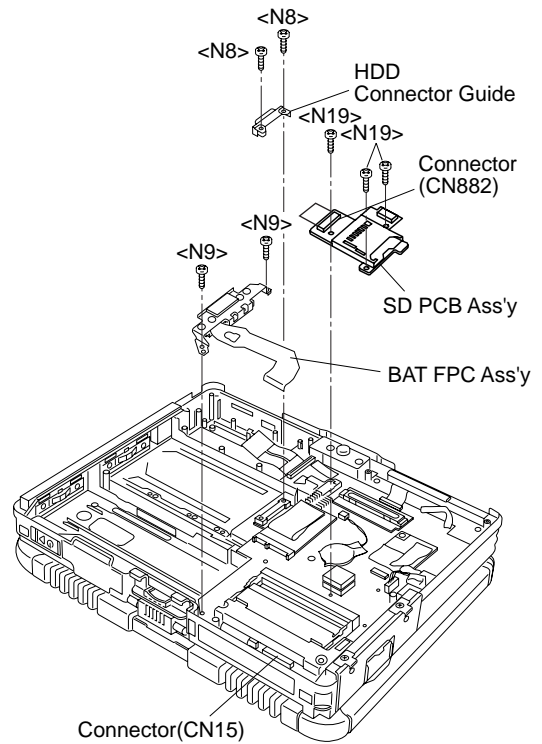

14. Fix the DU PCB and the Plate using the 2 screws <N3>.
15. Fix the DU PCB Ass'y and Antenna PCB using the 3 screws <N9> and the 2 screws <N3> .
16. Connect the white, black and gray Cables.

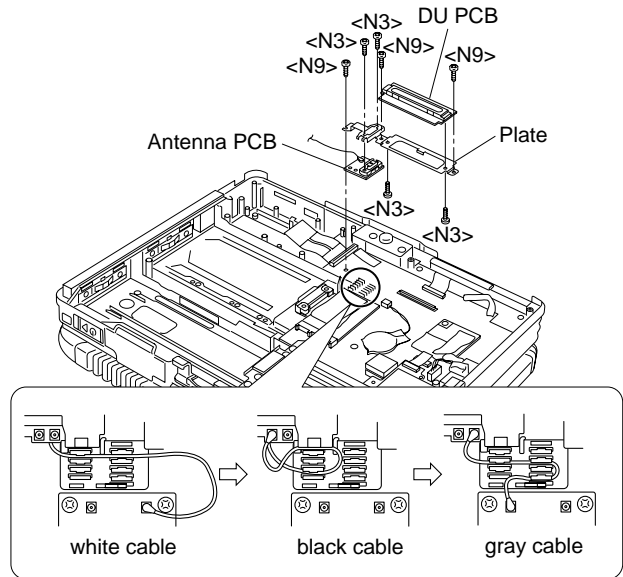

17. Turn the computer over, open the Display Unit, and then connect the 2 LCD Cables. (CN8,CN17)

Note:
Tighten the Screws in the numbered order (No1 to No7).

- Screws <N3> : DFHE5108ZA
- Screws <N8> : DRSB2+10FKL
- Screws <N9> : DRSB2+5FKL
- Screws <N19> : XSB2+3FNL

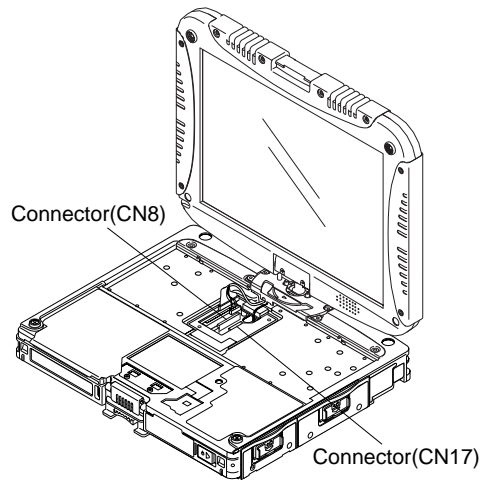

Assembly of Main PCB

Process in the order of 1→2→3→4.

①

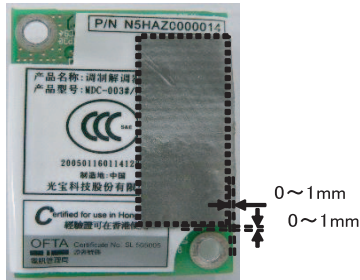

②

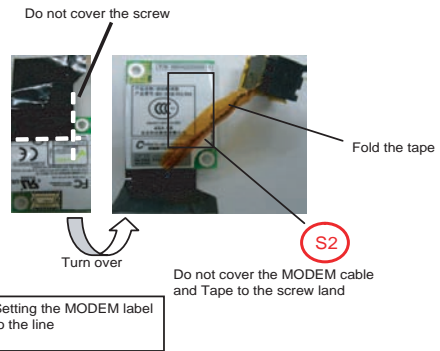

③

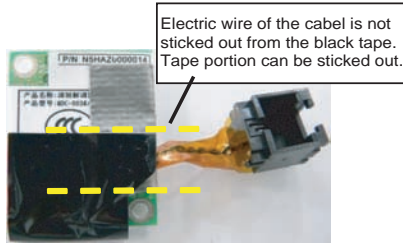

④

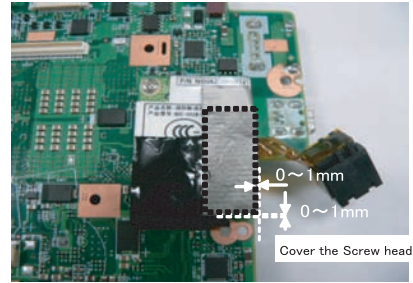

Safety Working

CAUTION S1:Insulation S2:Pinching Cables S3:Sharp Edge
S4:Part No. Check S5:Others

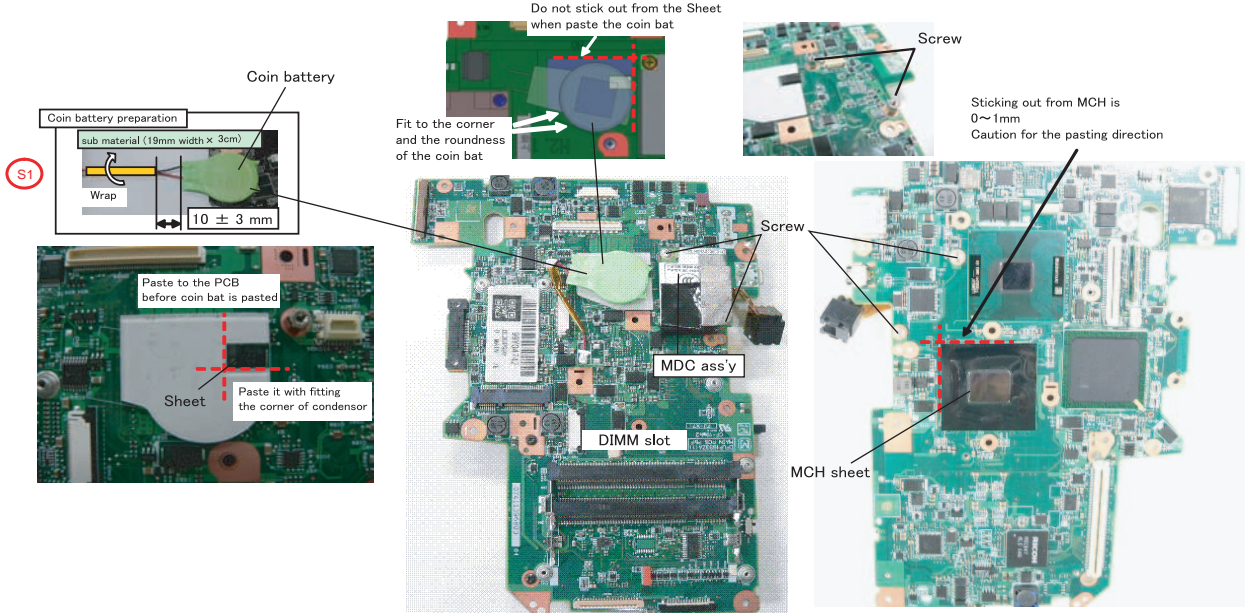



Attach the DIMM after the sheet is pasted

Do not cover the land of the chip parts

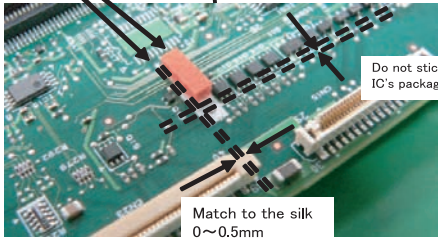

Do not stick off from the next IC's package to the edge of PCB

Match to the silk 0~0.5mm

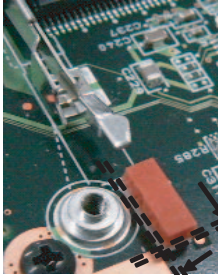

Match to the silk 0~0.5mm

Match to the silk 0~0.5mm

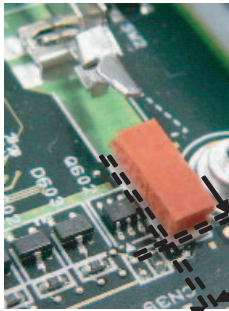

■ Assembly of Main Unit

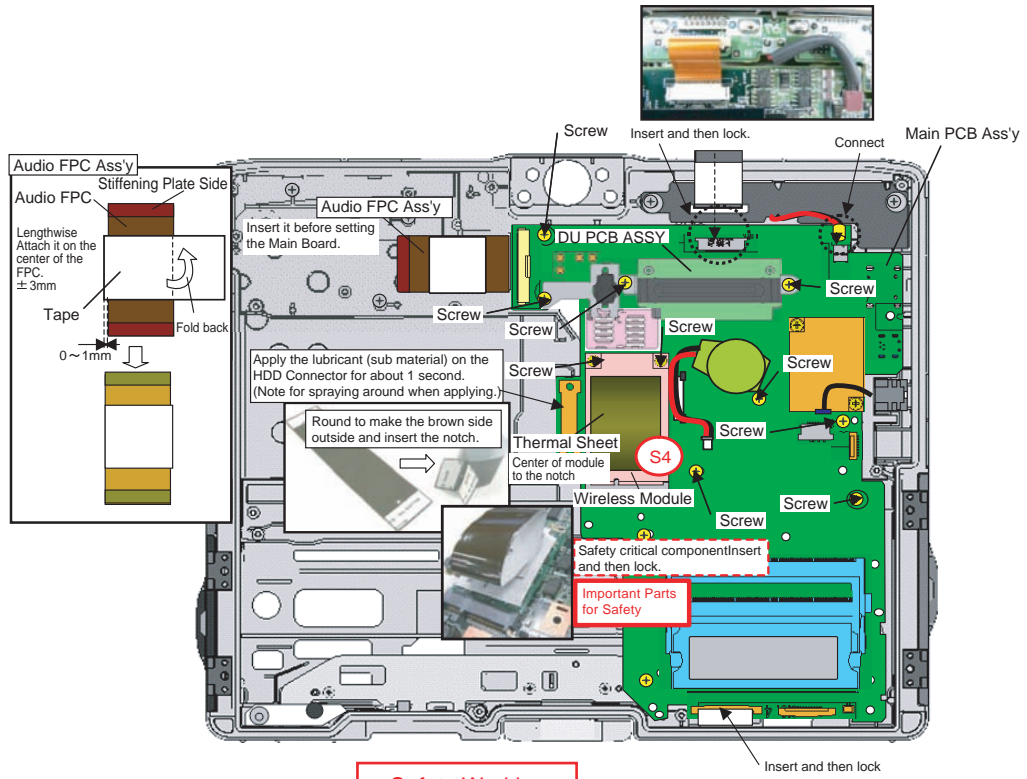

Safety Working

CAUTION S1:Insulation S2:Pinching Cables S3:Sharp Edge
S4:Part No. Check S5:Others

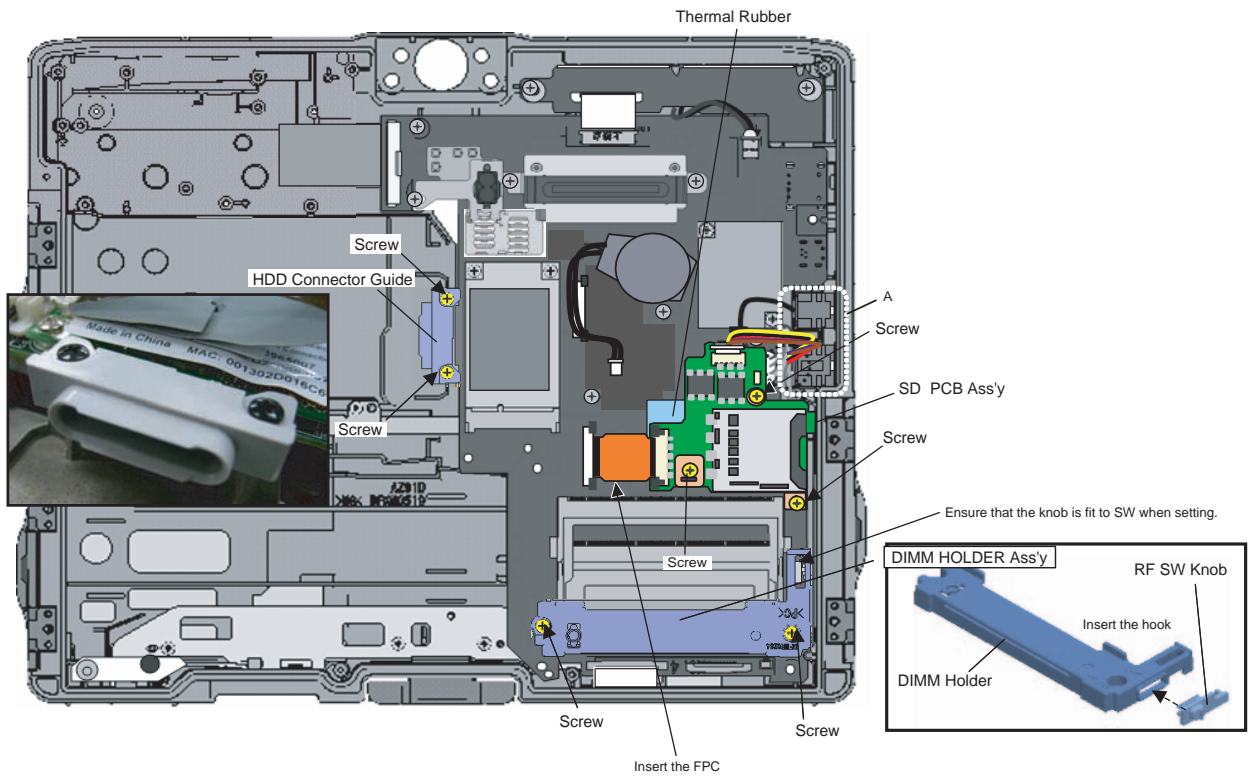

Safety Working

CAUTION S1:Insulation S2:Pinching Cables S3:Sharp Edge
S4:Part No. Check S5:Others

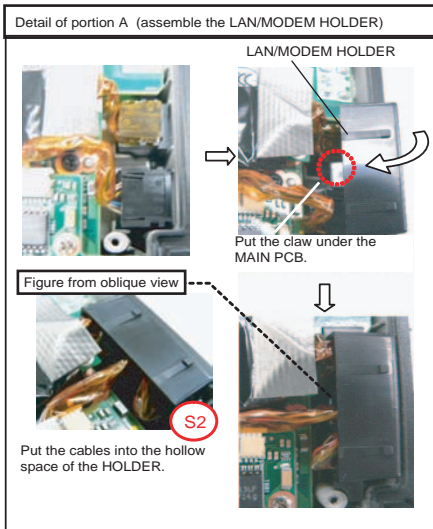

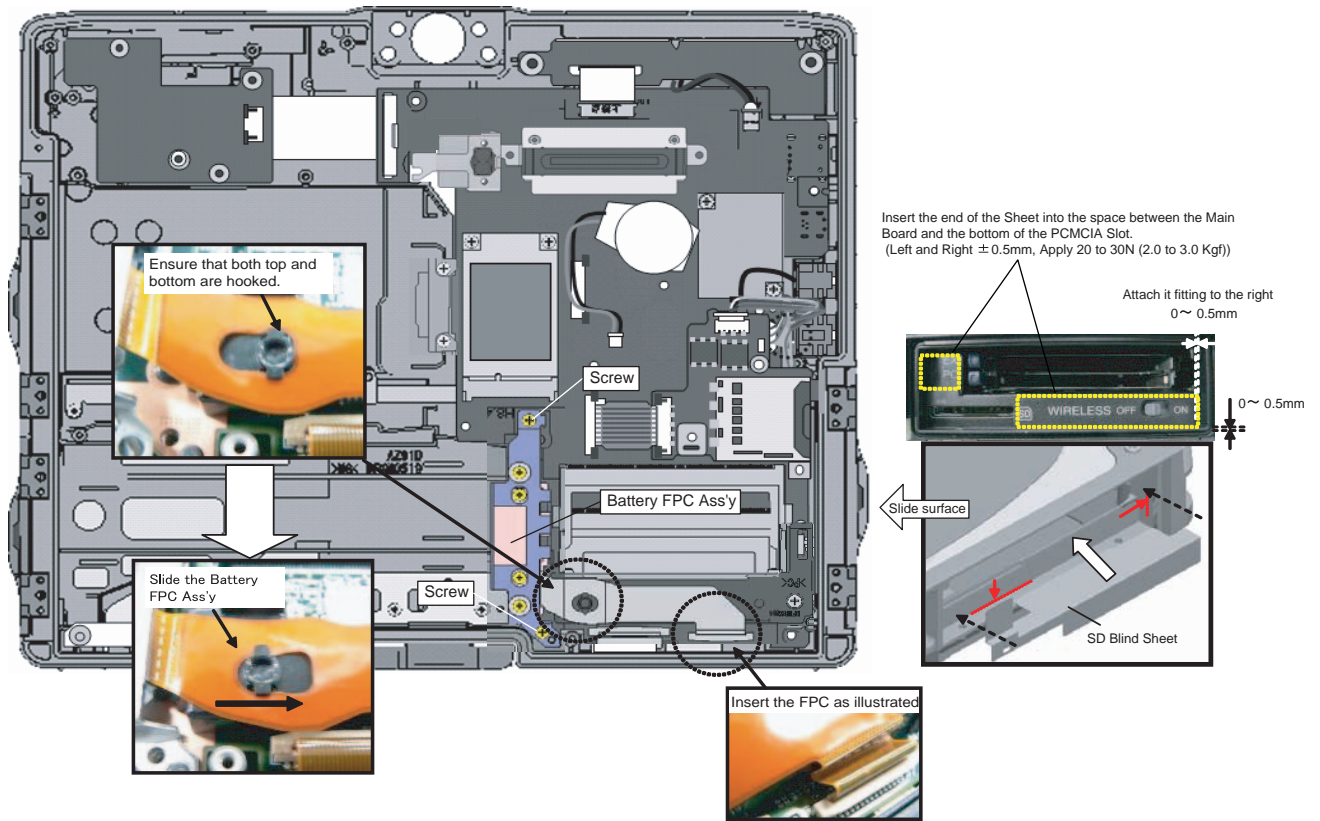

9.2.12. Setting the Audio PCB

1. Connect the Cable to the Connector. (CN901)
2. Fix the Audio PCB using the 3 Screws. <N9>

Note:

Tighten the Screws in the numbered order (No1 to No3).

Screws <N9> : DRSB2+5FKL

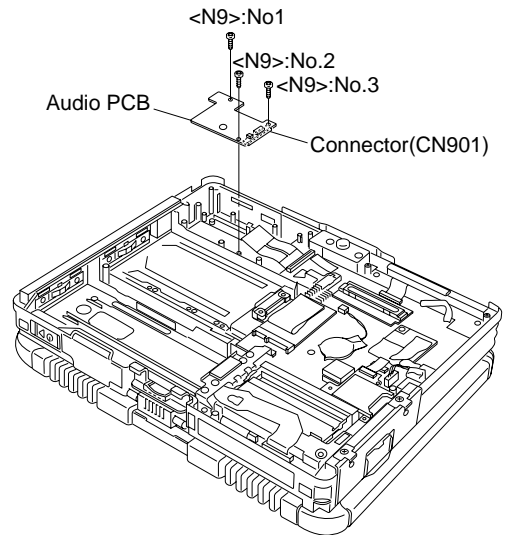

9.2.13. Setting the HSDPA PCB and Bluetooth PCB

1. Fix the Plate and Bluetooth PCB using the 2 Screws <N19>.
2. Connect the Cable to the Connector. (CN1)
3. Connect the Cable to the Connector. (CN604)
4. Fix the Plate and the Board using the 4 Screws <N19>.
5. Attach the blue Antenna Cable to the Clamper.

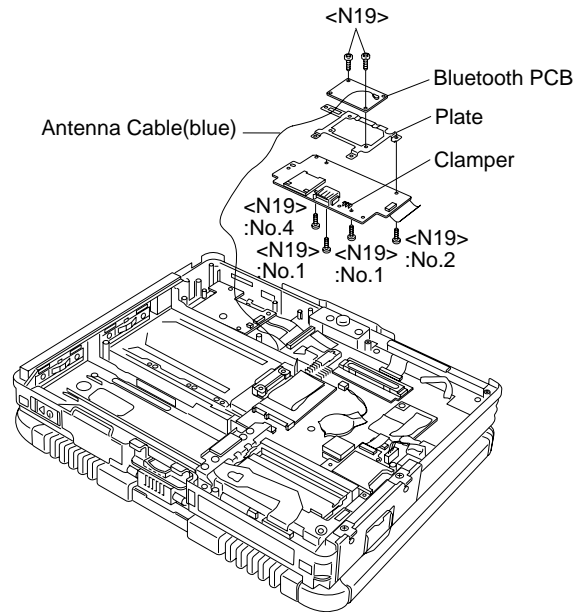

6. Connect the Cable to the Connector. (CN600)
7. Fix the RF PCB Ass'y using the 4 Screws. <N9>
8. Attach the Tape.
9. Attach the brown and black Antenna Cables.
10. Attach the Cable Holder Cushion.

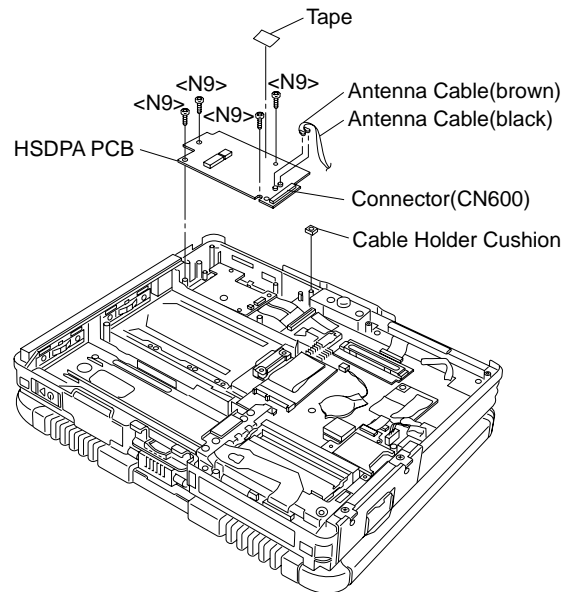

Screws <N9> : DRSB2+5FKL
 Screws <N19> : XSB2+3FNL

Line Processing of Antenna Cable of Main Unit

Cable Process 1/3

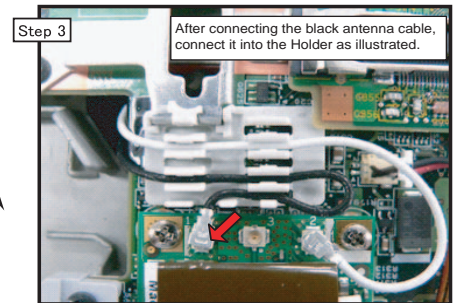
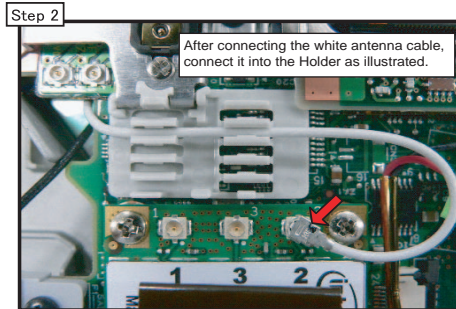
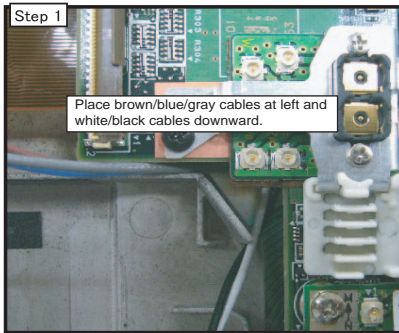
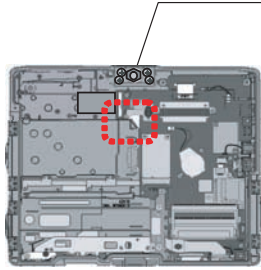

Safety Working

CAUTION

S1:Insulation S2:Pinching Cables S3:Sharp Edge
S4:Part No. Check S5:Others

Cable Process 2/3

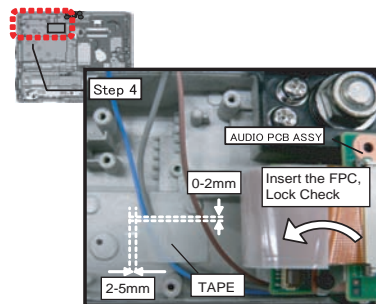

After processing the cables, inserting the FPC and locking, incline the Audio PCB into the arrow direction.

After confirming the cable is not under the AUDIO PCB (processed at the Step 4), tighten the Screws. Because there is a possibility that the cable is scissored between PCB and the both.

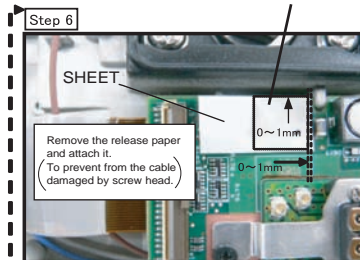
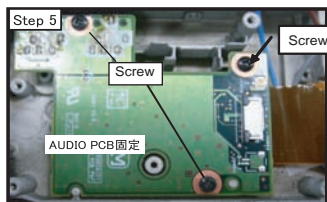

Process the grey cable to the same direction with the brown cable

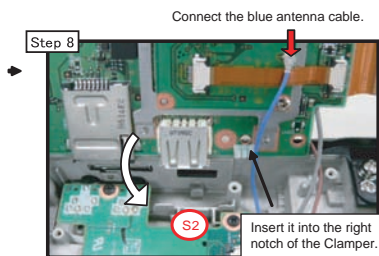
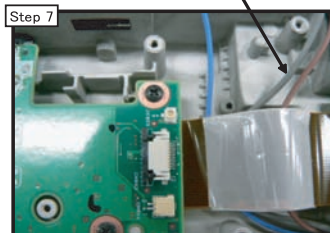

If the fixing is not incorrected, there is possibility that the cable is scissored between the PCB and the both.

Check the blue cable from the hole.



Connect the FPC

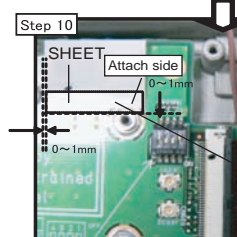

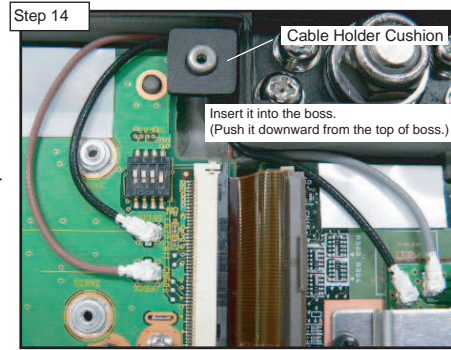
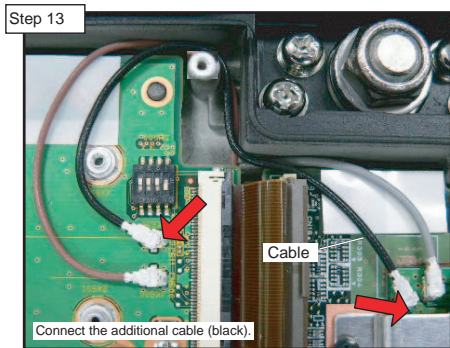
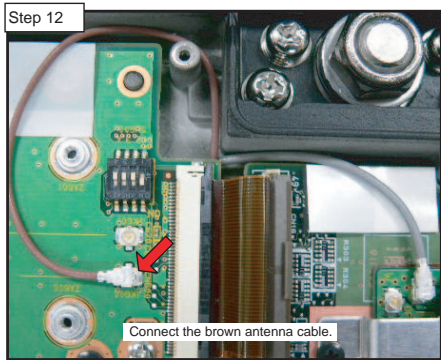

Cable Process 3/3 ①

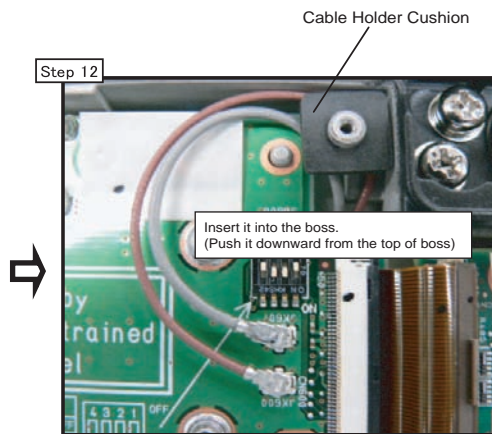
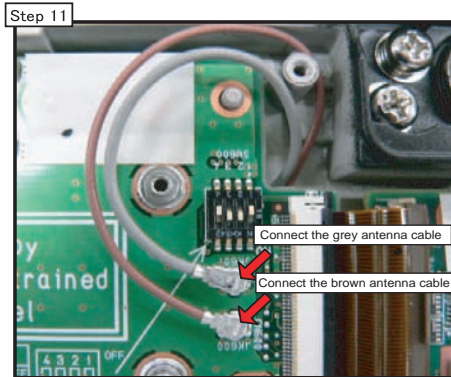

9.2.14. Assembling the DU Lid Unit

1. Fix the DU Lid Angle and the DU Lid using the 7 Screws.
<K14-9>

Screws <K14-9> : DXQT2+D25FNL

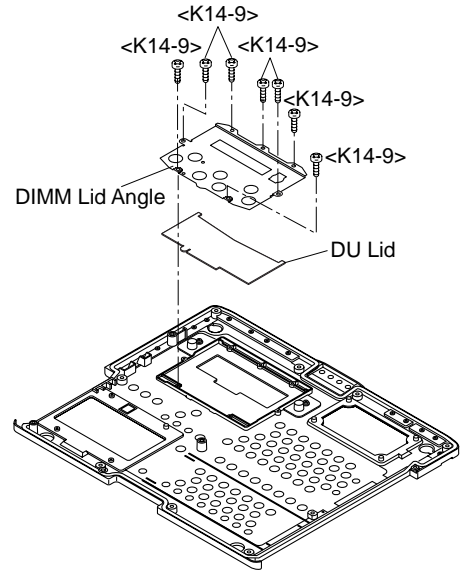

9.2.15. Setting the Rear Cabinet

1. Fix the Rear Cabinet on the Computer using the 13 Screws. <N10>
2. Close the Lid Covers.

Note:

Tighten the Screws in the numbered order (No1 to No13).

Screws <N10> : DRHM0061ZA

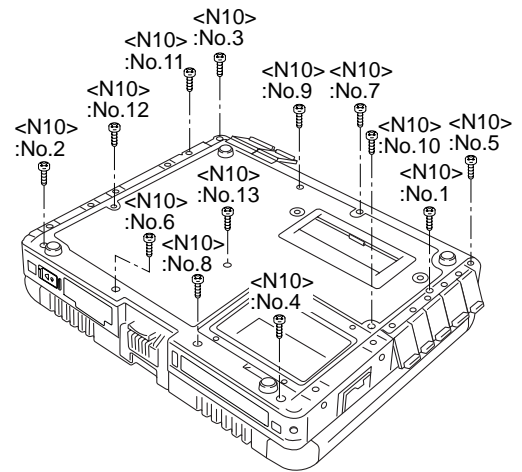

■ Cautions for Setting the Rear Cabinet

(Note) Arrow without specified measurement: 0 to 0.5 mm

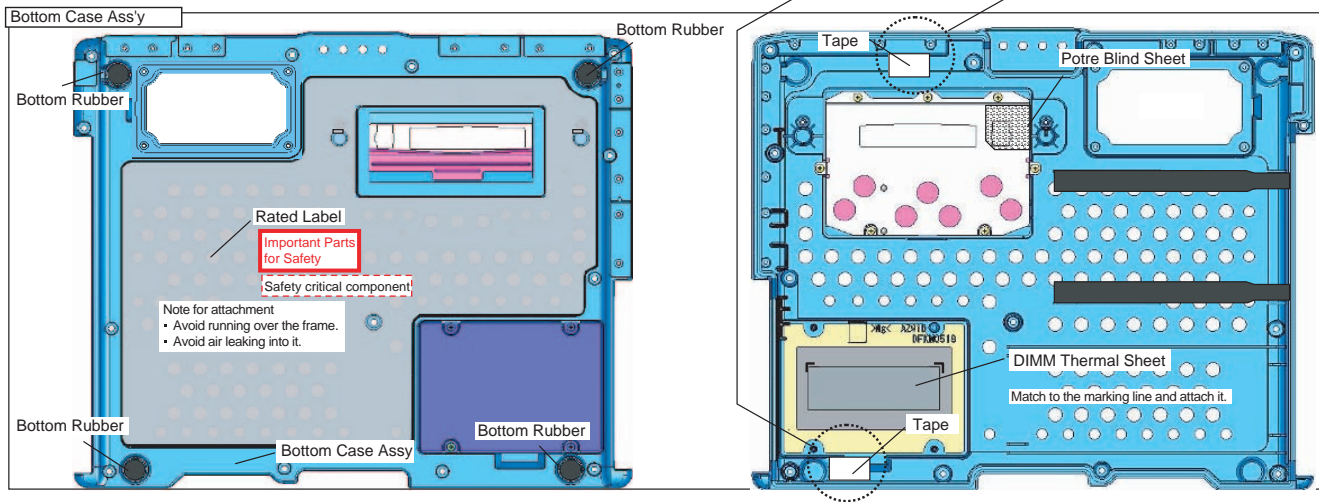

9.2.16. Setting the DIMM Lid Ass'y

1. Fix the DIMM Lid Ass'y using the 4 Screws. <K14-8>

Screws <K14-8> : DRHM5025YAT

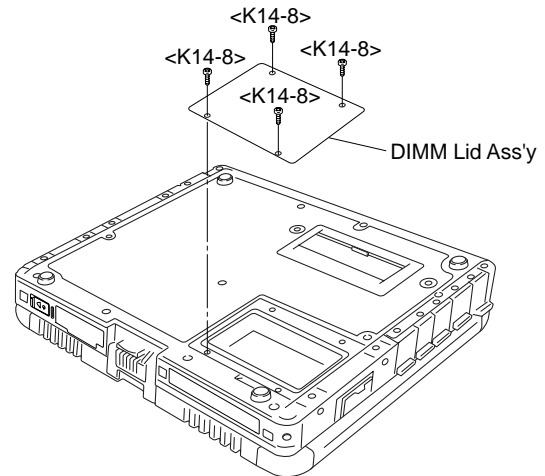

9.2.17. Setting the Touch Pad and Keyboard

1. Connect the Cable to the Connector (CN800), and attach the Touch Pad to the computer.
2. Set the Click Button Plate.
3. Attach the new TP Tape over the Touch Pad.
4. Attach the Palm Rest Ass'y on the computer.

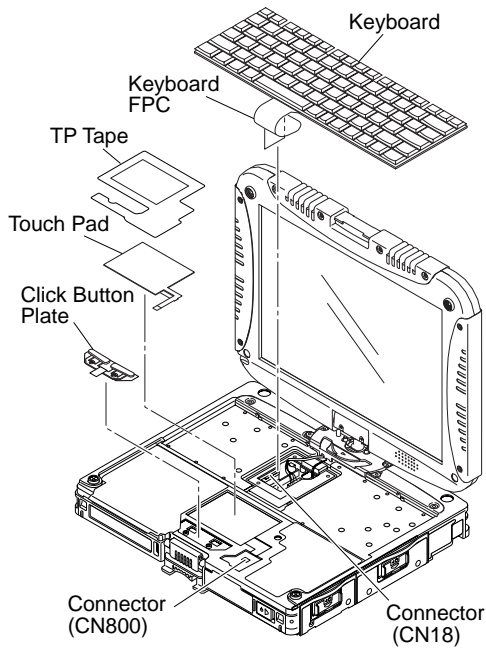

5. Connect the Cable of the Keyboard to the Connector (CN18) on the Main PCB.
6. Fix the KBD Connector Cover using the three Screws. <N1>

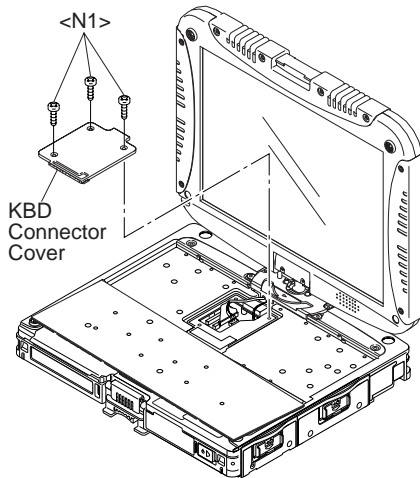

7. Set the Keyboard to the computer.

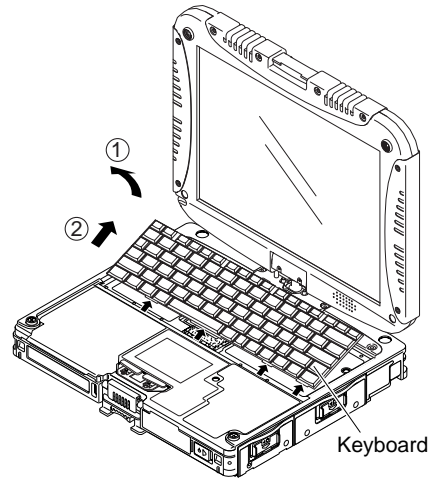

8. Fix the KBD Plate using the four Screws. <N9>

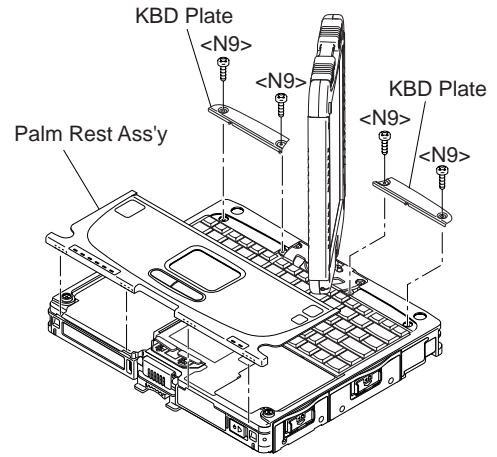

Screws <N1> : DFHE5025XA
Screws <N9> : DRSB2+5FKL

■ Putting of the Sheet

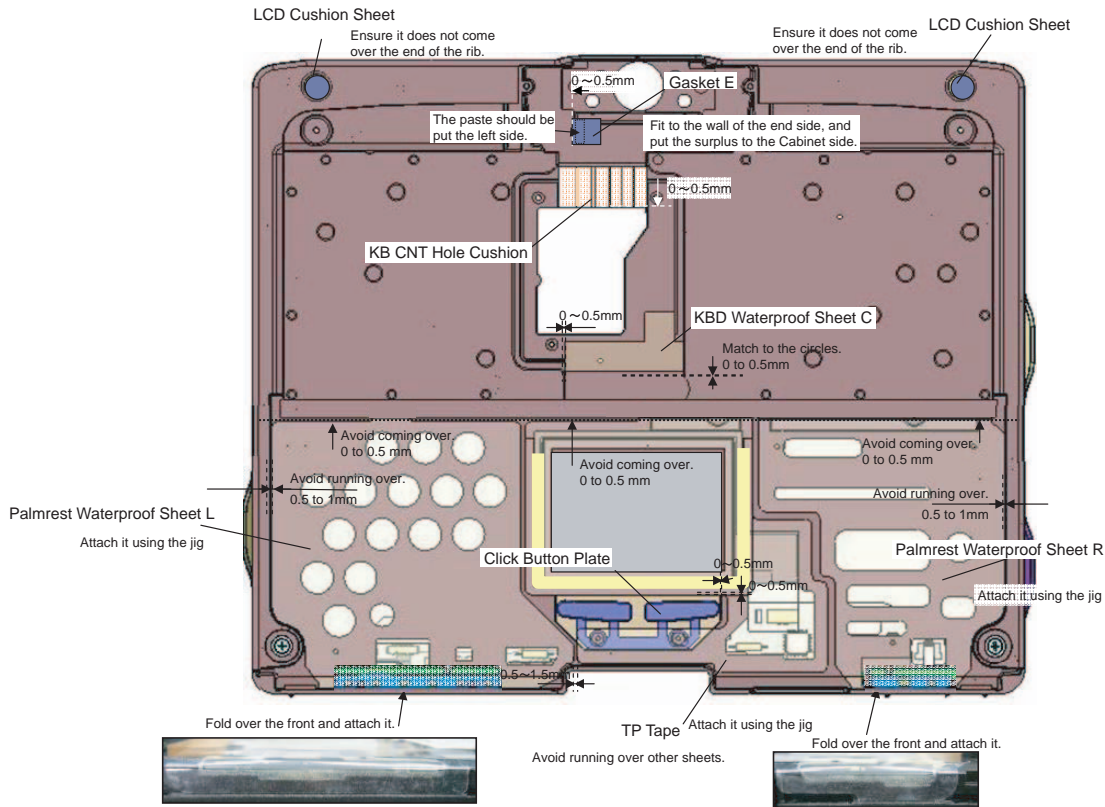

Because the sheets described on this page are waterproof sheets, the whole parts should be put pressure after attaching. (Especially, put pressure around the sheets.)

*Apply the load to attach. 30 to 40N (3.0 to 4.0Kgf)

■ Cautions for Setting the Keyboard

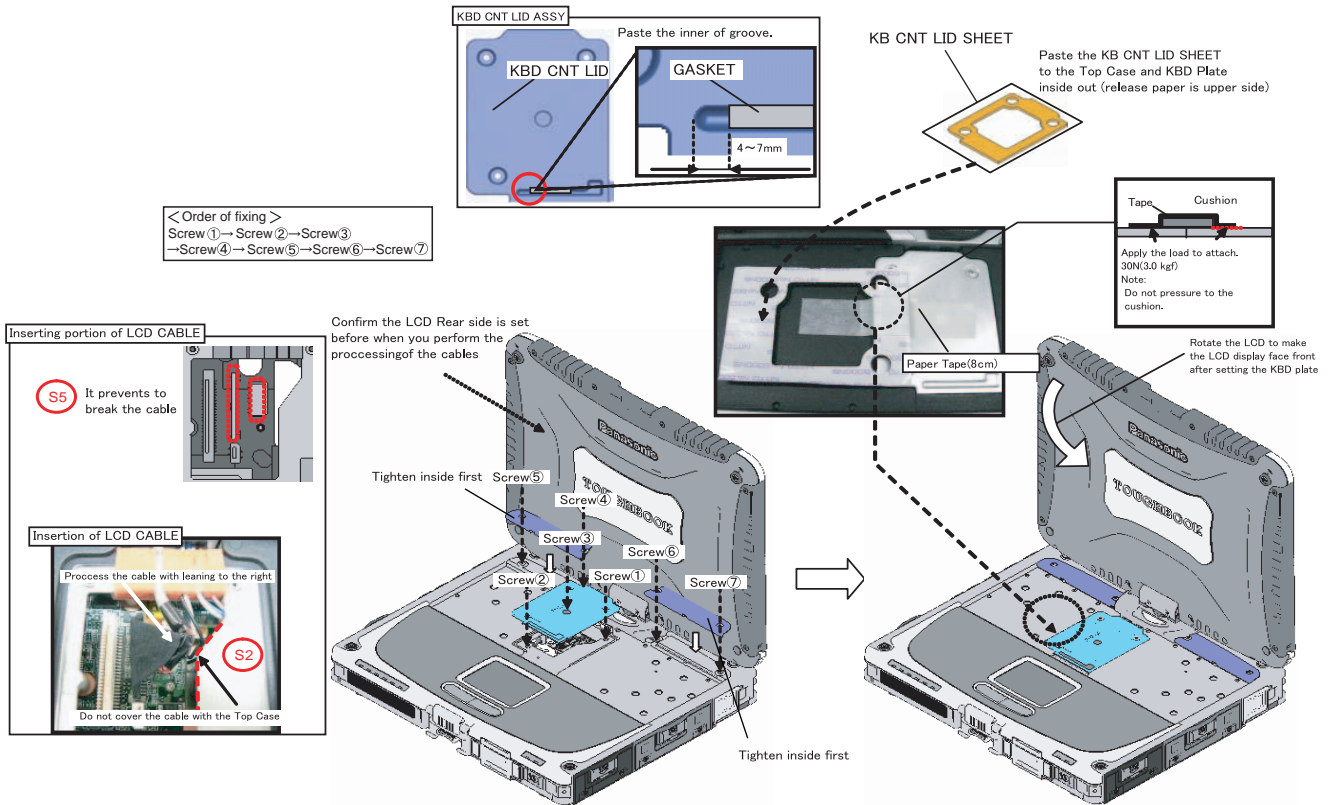

■ Putting of the Palm Rest ASSY

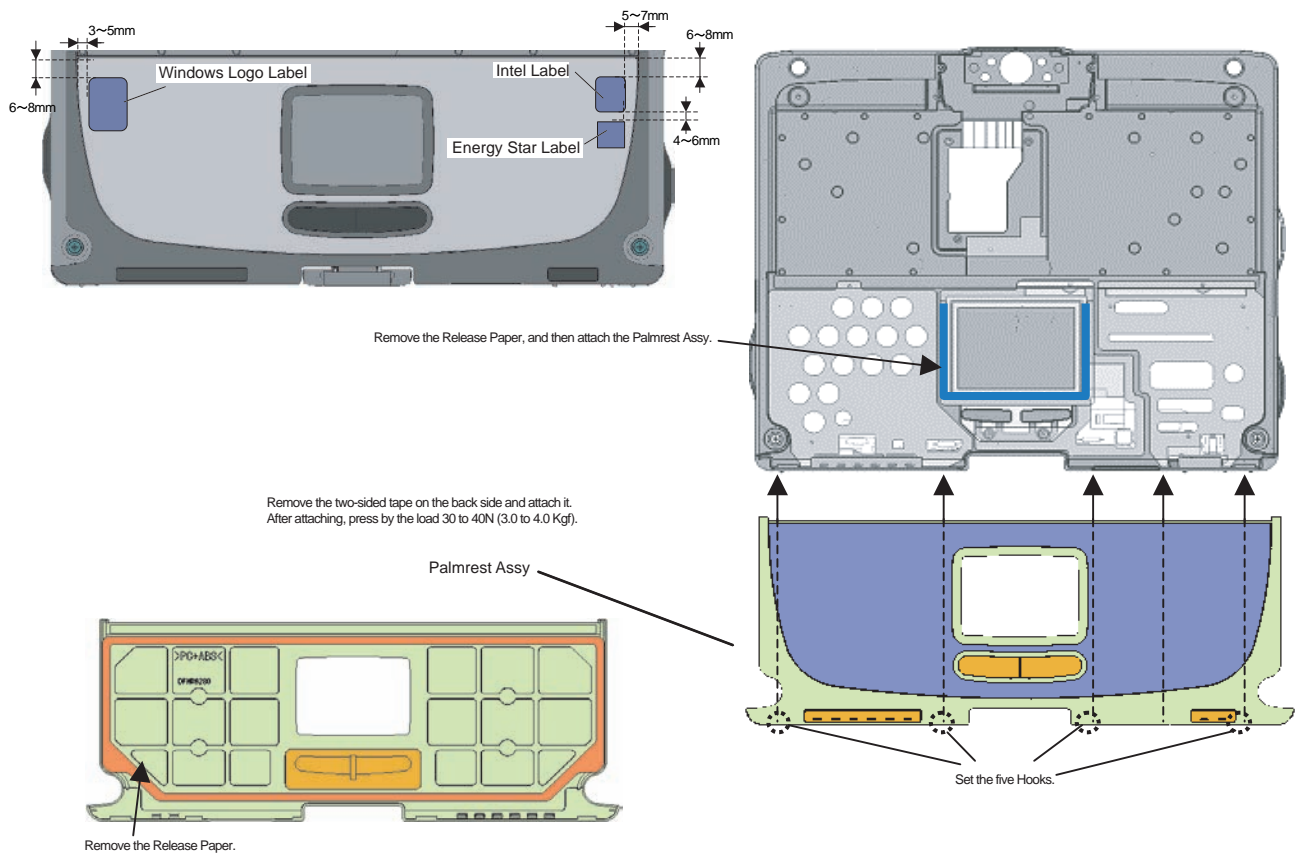

■ Putting of the KBD Tape

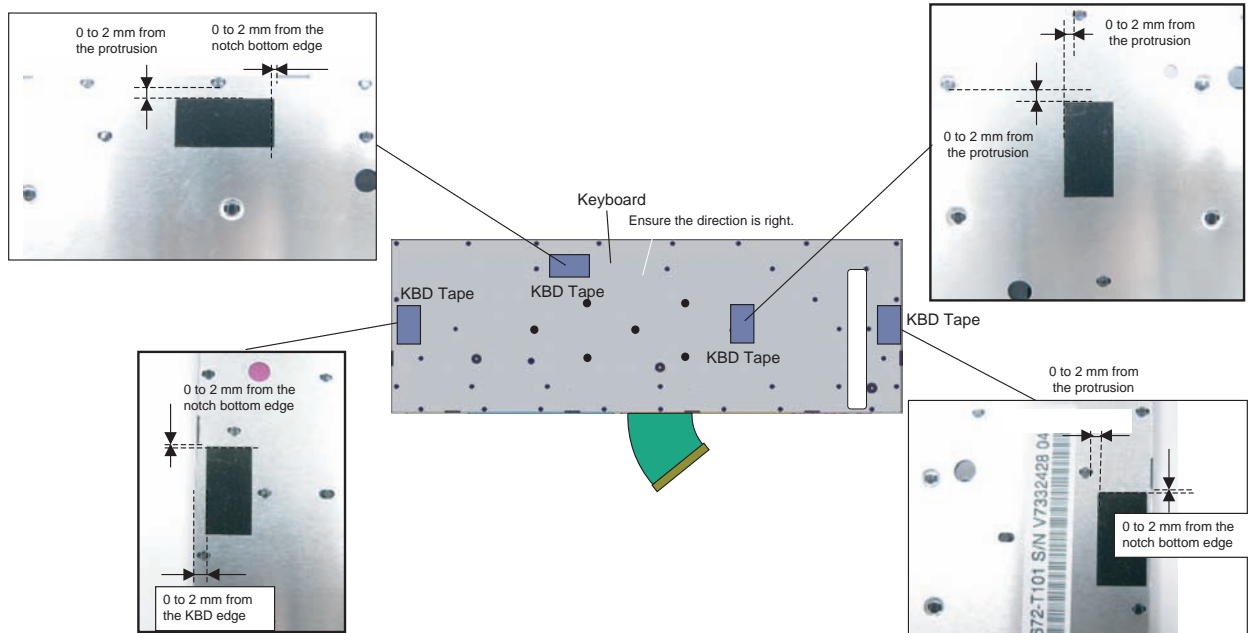

9.2.18. Setting the Battery Pack and the HDD Pack

1. Set the HDD in the HDD Case and fix it using the 2 Screws. <N13>

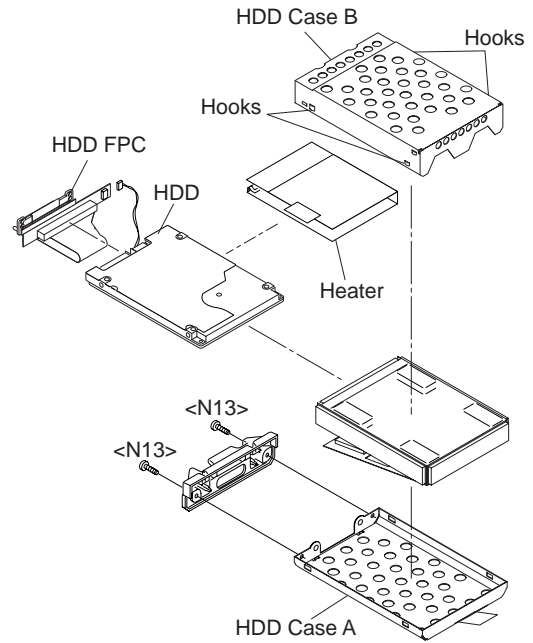

2. Open the HDD Cover and set the HDD Pack.
3. Open the Battery Cover and set the Battery.

Screws <N13> : DXQT2+D4FNL

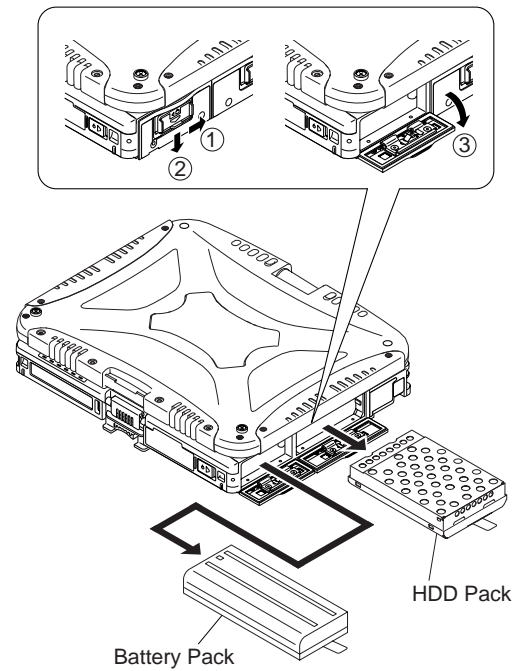

■ Assembly of the HDD ASSY

Safety Working

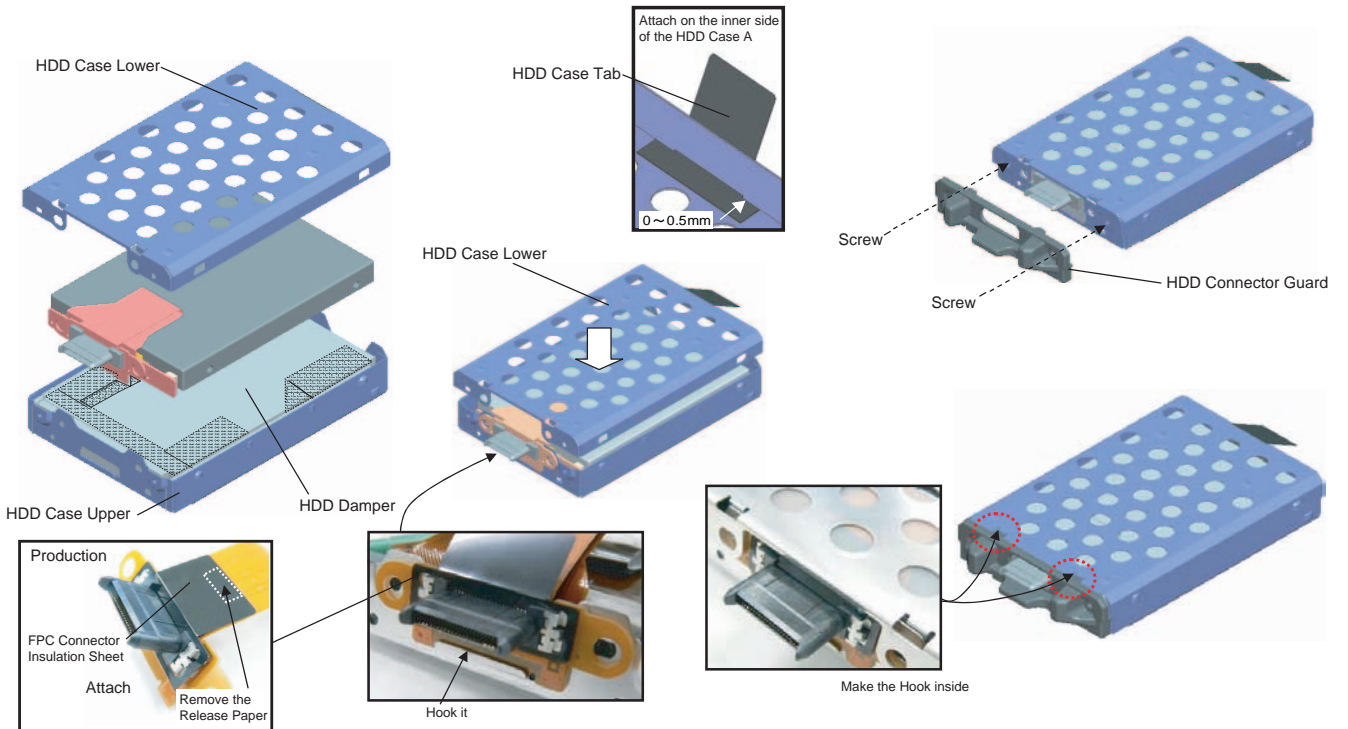
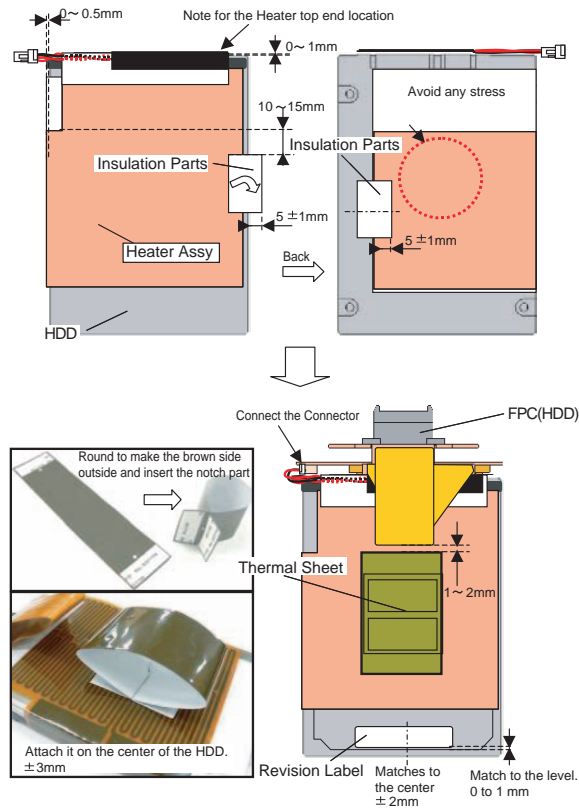
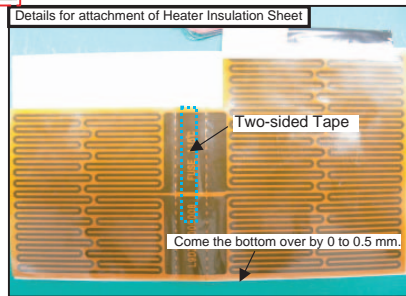
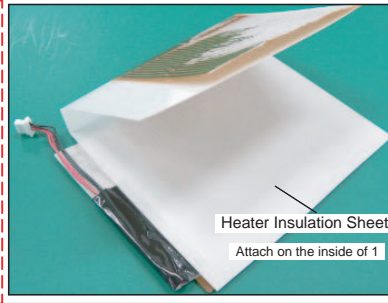
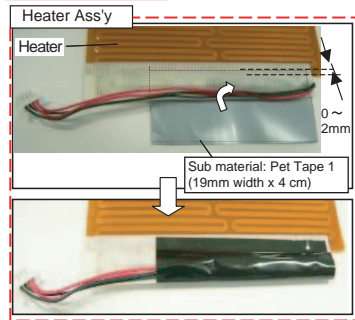

9.2.19. Assembling the Each Cover

1. Fix the Battery LID Ass'y, the HDD LID Ass'y, and the PCMCIA LID Ass'y using the 6 Screws. <K12-16>
2. Set the Rear Cabinet.
3. Fix the Modem/LAN LID Rubber, the LAN LID Rubber, the USB LID Rubber, the DC IN LID Rubber, the Serial LID Rubber, the RGB LID Rubber, the Audio LID Rubber and USB Back Rubber using the 14 Screws. <N6>

Note:

Tighten the Screws in the numbered order (No1 to No14).

Screws <K12-16> : DRQT26+D3FKL

Screw <N6> : DRHM5025YA

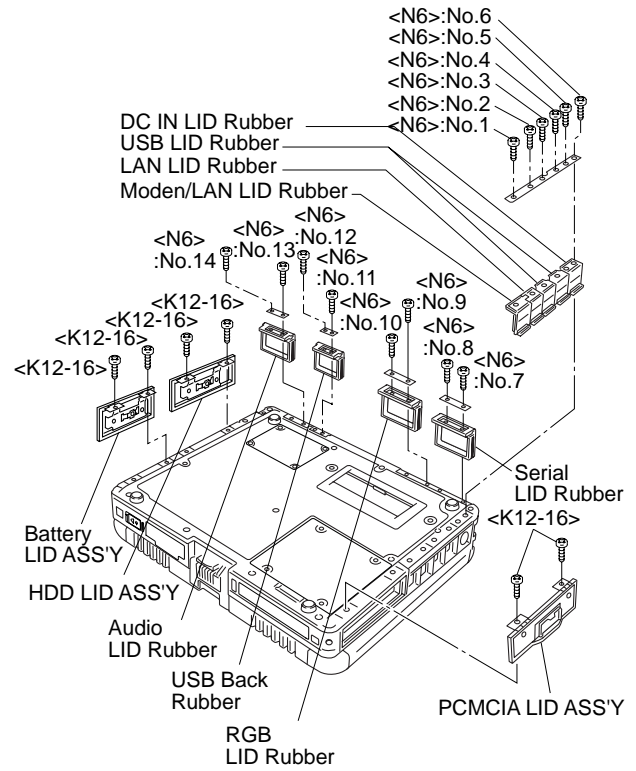

10 Exploded View

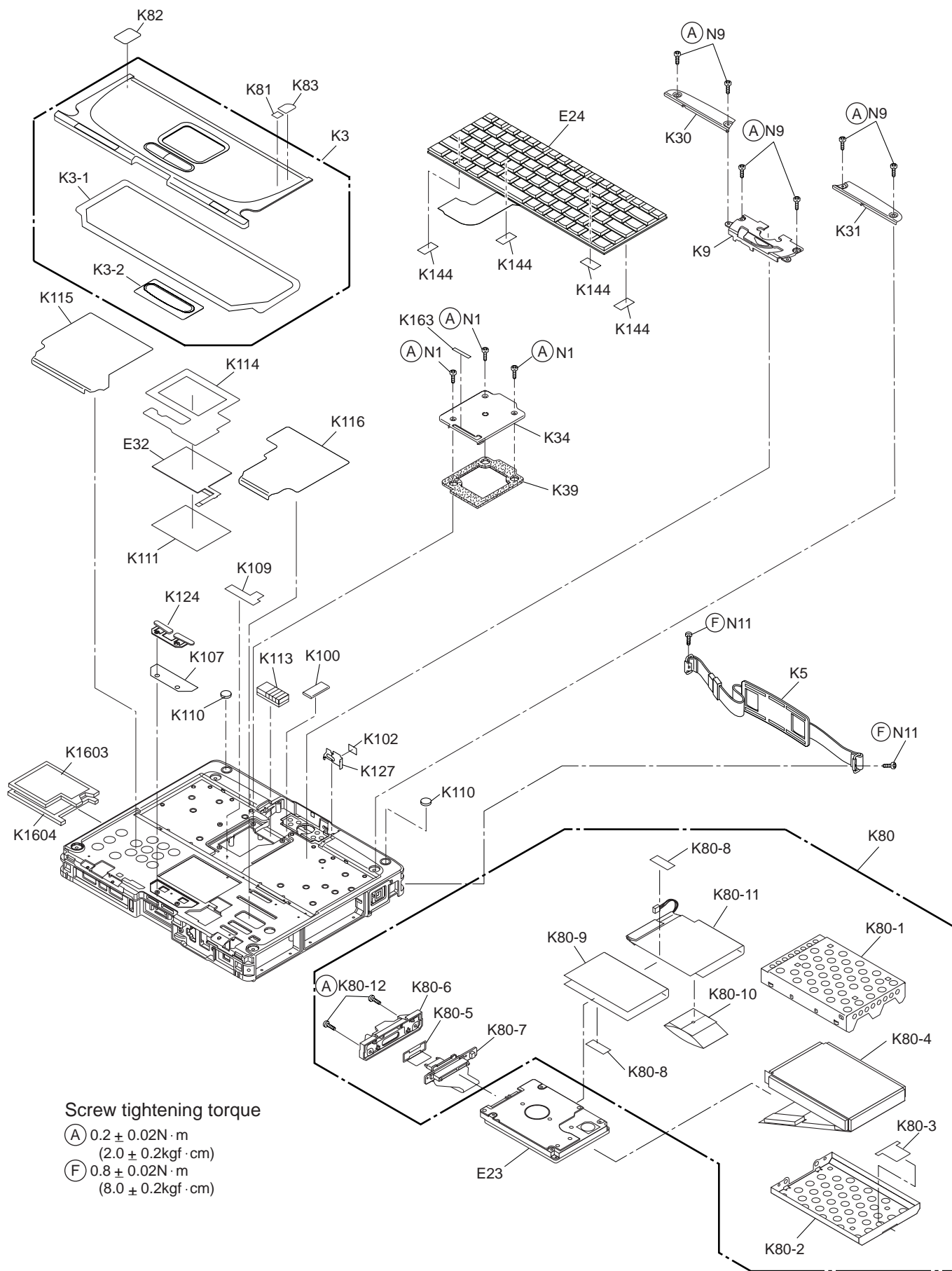

Screw tightening torque

- (A) $0.2 \pm 0.02\text{N} \cdot \text{m}$
($2.0 \pm 0.2\text{kgf} \cdot \text{cm}$)
- (F) $0.8 \pm 0.02\text{N} \cdot \text{m}$
($8.0 \pm 0.2\text{kgf} \cdot \text{cm}$)

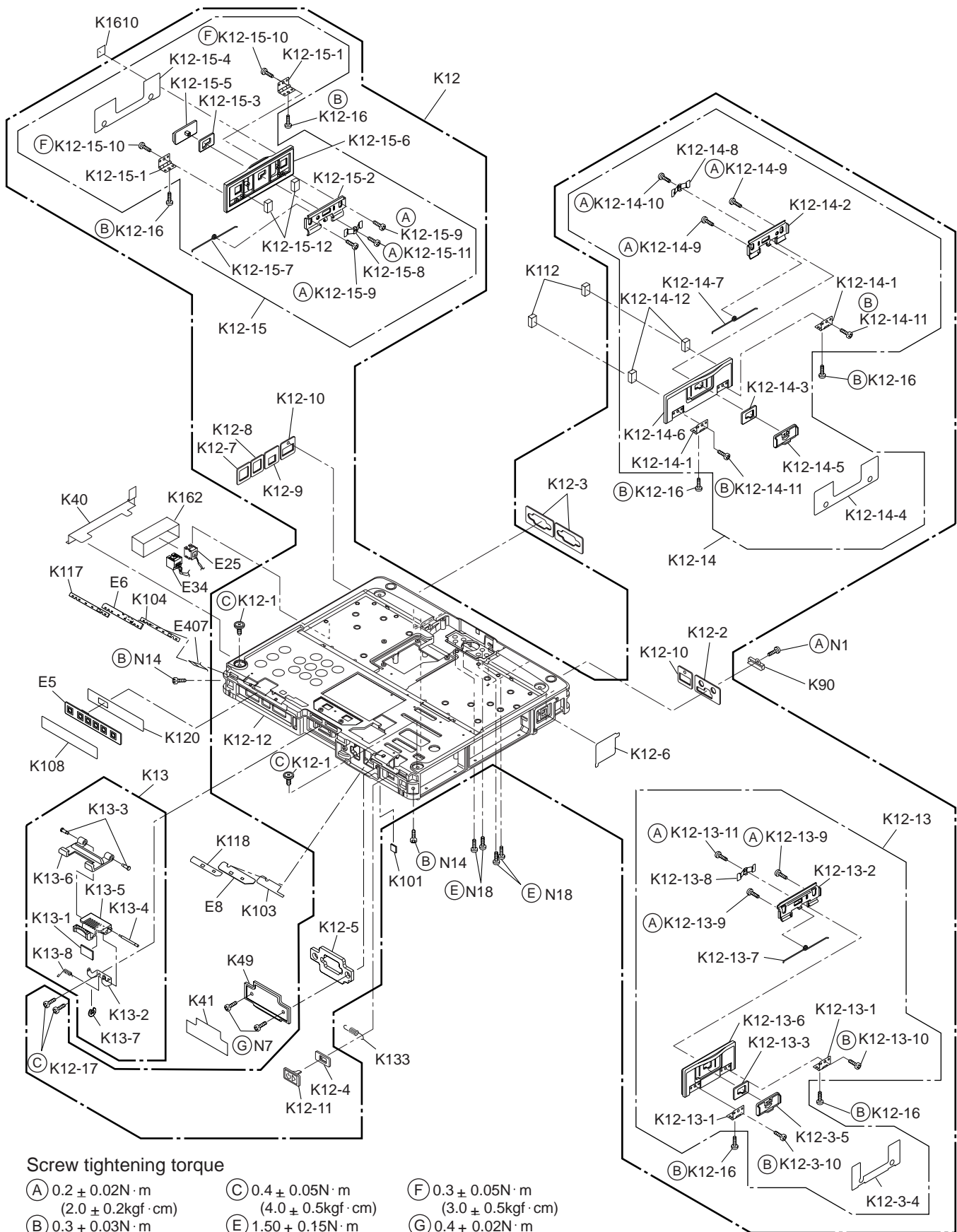

Screw tightening torque

- (A) $0.2 \pm 0.02 \text{ N} \cdot \text{m}$
($2.0 \pm 0.2 \text{ kgf} \cdot \text{cm}$)
- (B) $0.3 \pm 0.03 \text{ N} \cdot \text{m}$
($3.0 \pm 0.3 \text{ kgf} \cdot \text{cm}$)
- (C) $0.4 \pm 0.05 \text{ N} \cdot \text{m}$
($4.0 \pm 0.5 \text{ kgf} \cdot \text{cm}$)
- (E) $1.50 \pm 0.15 \text{ N} \cdot \text{m}$
($15.0 \pm 1.5 \text{ kgf} \cdot \text{cm}$)
- (F) $0.3 \pm 0.05 \text{ N} \cdot \text{m}$
($3.0 \pm 0.5 \text{ kgf} \cdot \text{cm}$)
- (G) $0.4 \pm 0.02 \text{ N} \cdot \text{m}$
($4.0 \pm 0.2 \text{ kgf} \cdot \text{cm}$)

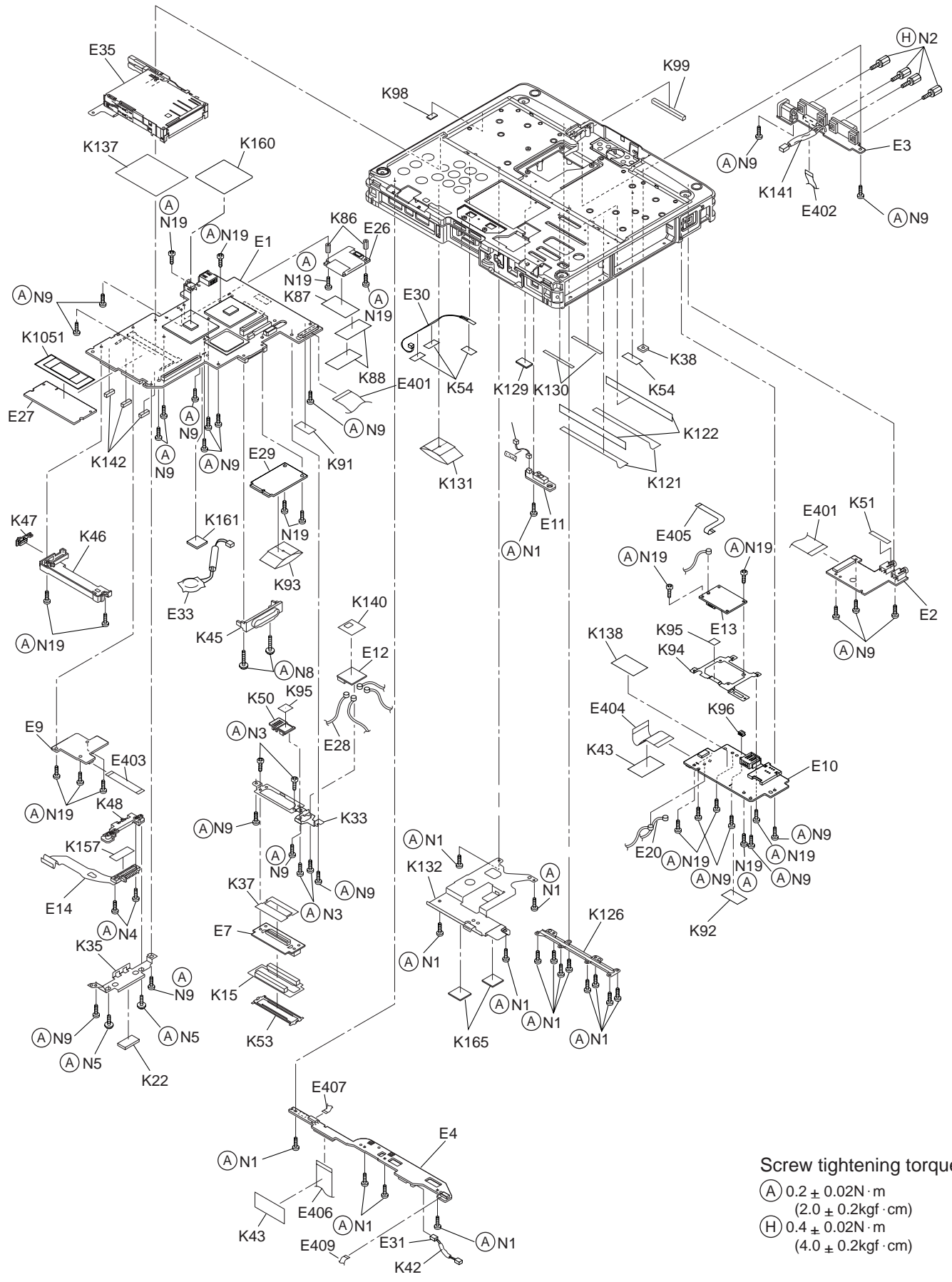

Screw tightening torque

- (A) $0.2 \pm 0.02 \text{ N} \cdot \text{m}$
($2.0 \pm 0.2 \text{ kgf} \cdot \text{cm}$)
- (H) $0.4 \pm 0.02 \text{ N} \cdot \text{m}$
($4.0 \pm 0.2 \text{ kgf} \cdot \text{cm}$)

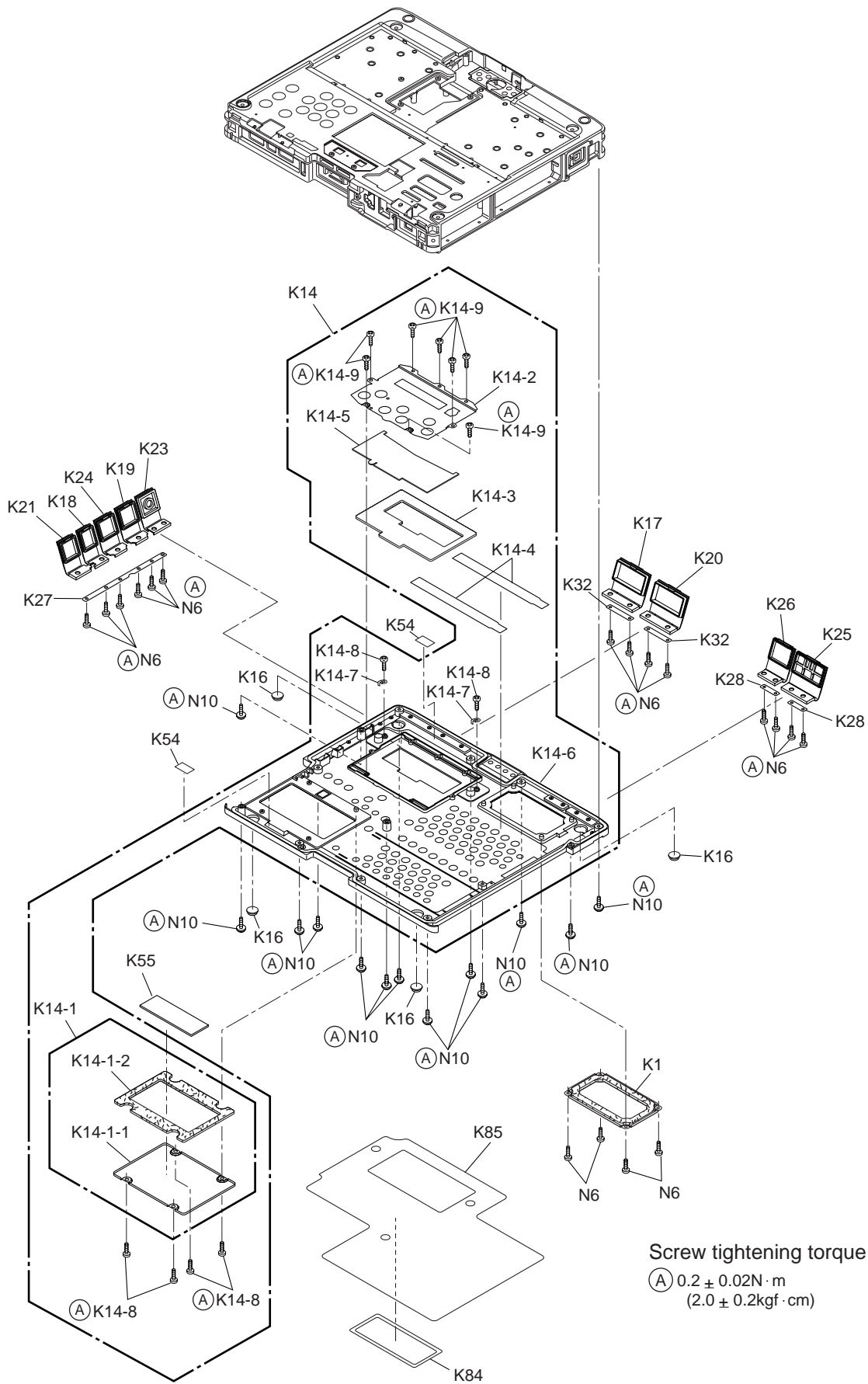

Screw tightening torque
 (A) $0.2 \pm 0.02 \text{ N} \cdot \text{m}$
 ($2.0 \pm 0.2 \text{ kgf} \cdot \text{cm}$)

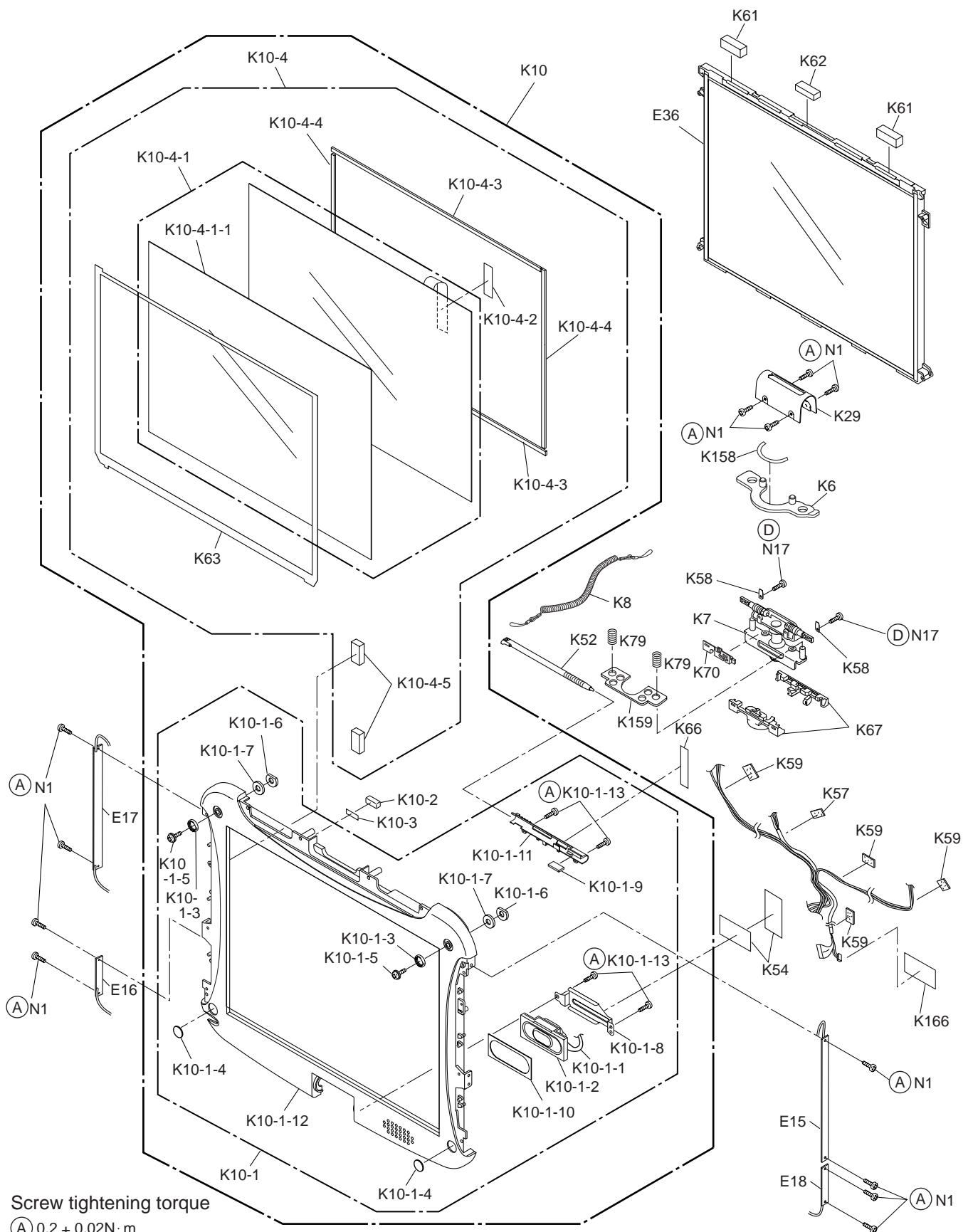

Screw tightening torque

- (A) $0.2 \pm 0.02 \text{ N} \cdot \text{m}$
($2.0 \pm 0.2 \text{ kgf} \cdot \text{cm}$)
- (D) $0.8 \pm 0.08 \text{ N} \cdot \text{m}$
($8.0 \pm 0.8 \text{ kgf} \cdot \text{cm}$)

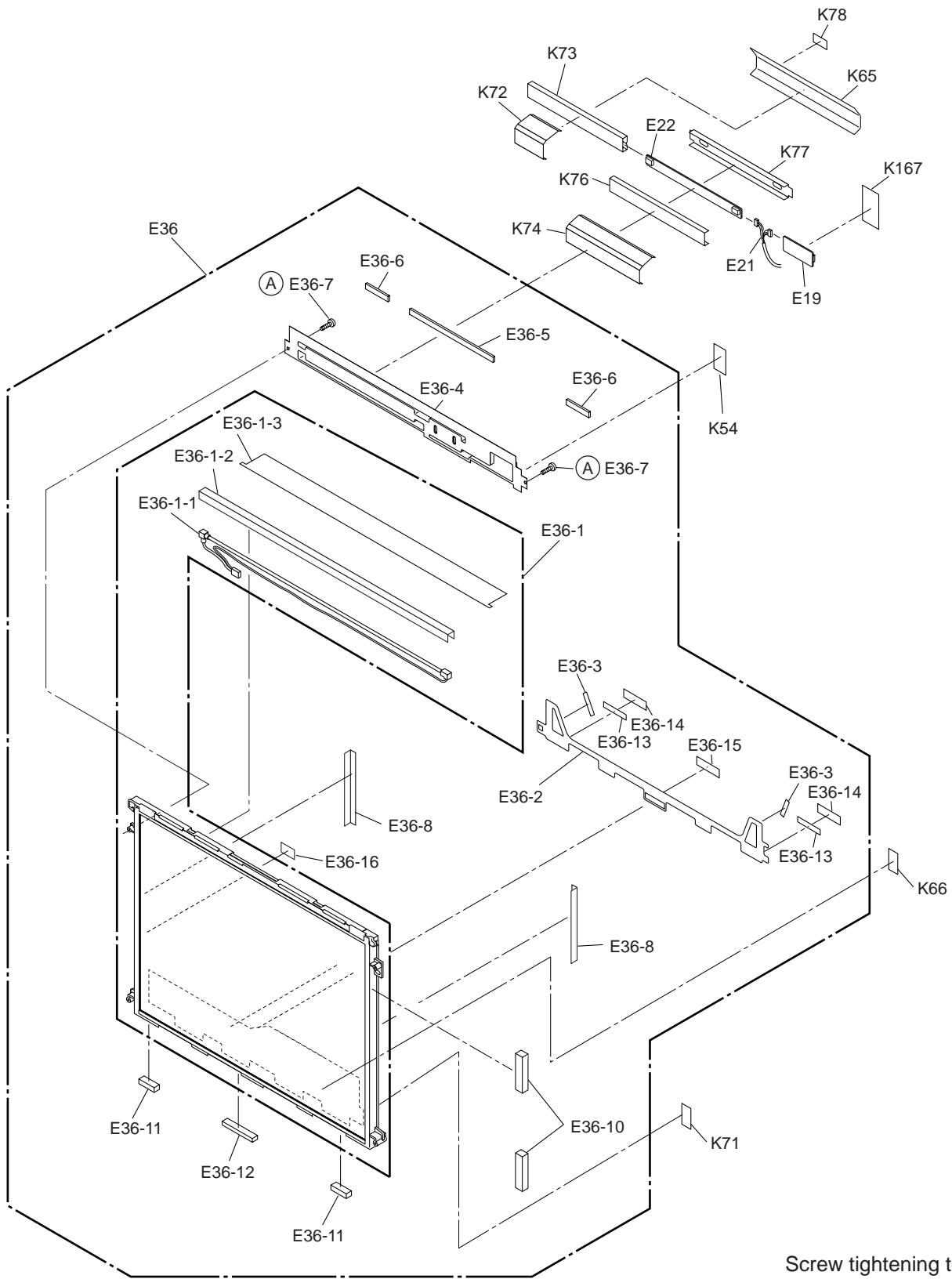

Screw tightening torque

(A) $0.18 \pm 0.02 \text{ N} \cdot \text{m}$
 $(1.8 \pm 0.2 \text{ kgf} \cdot \text{cm})$

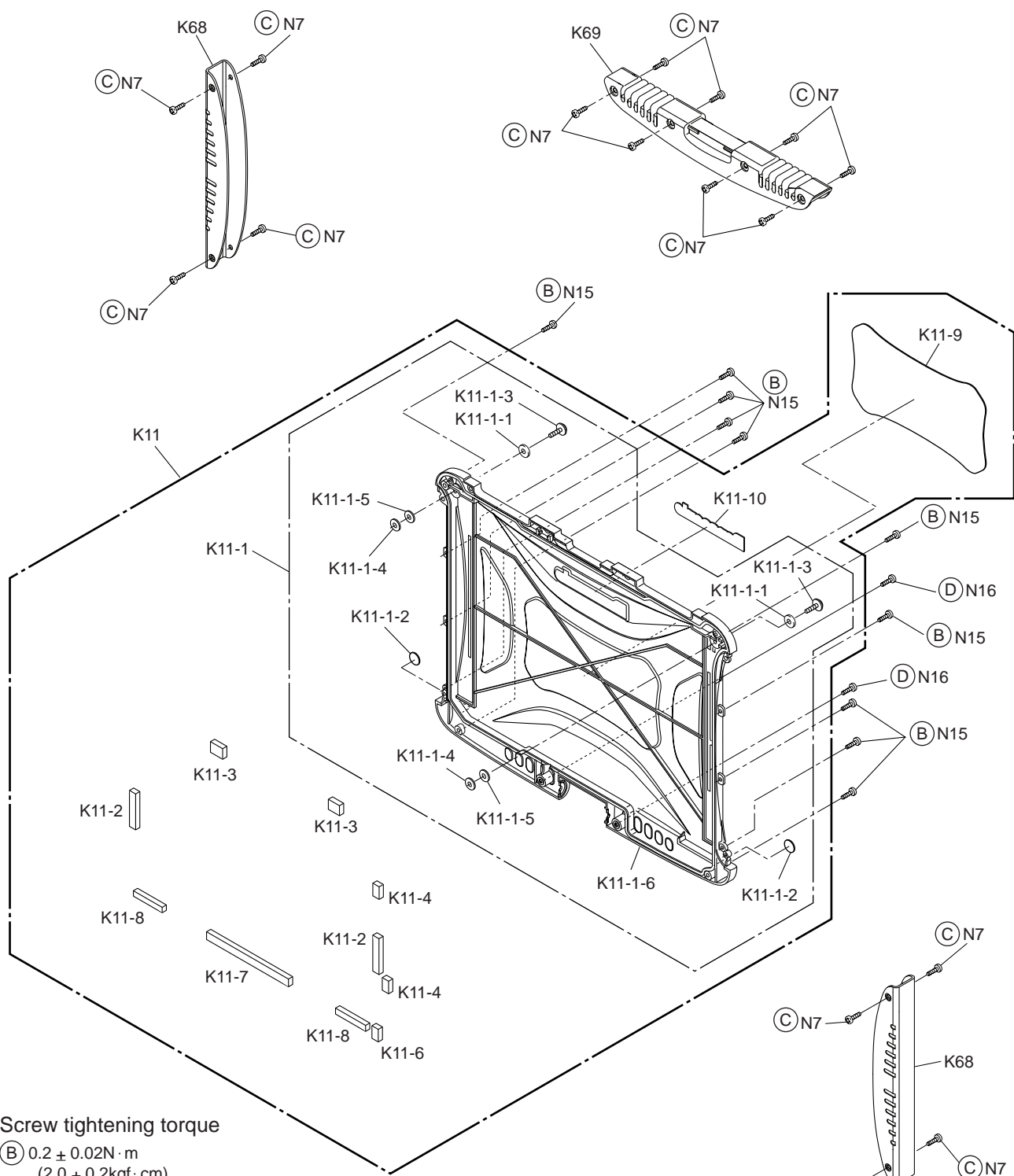

Screw tightening torque

- (B) $0.2 \pm 0.02\text{N} \cdot \text{m}$
($2.0 \pm 0.2\text{kgf} \cdot \text{cm}$)
- (C) $0.3 \pm 0.03\text{N} \cdot \text{m}$
($3.0 \pm 0.3\text{kgf} \cdot \text{cm}$)
- (D) $0.8 \pm 0.08\text{N} \cdot \text{m}$
($8.0 \pm 0.8\text{kgf} \cdot \text{cm}$)



Replacement Parts List

Note : Important Safety Notice

Components identified by  mark have special characteristics important for safety. When replacing any of these components, use only manufacturer's specified parts.

CF-19FHGAXxM

NRP: Non Reusable Parts

REF. NO and OS	PART NO.	DESCRIPTION	Q'TY
Main Block Unit			
E1	DL31U1633AAA	PCB, MAIN	RTL 1
E2	DL32U1633AAA	PCB, AUDIO	RTL 1
E3	DL33U1633AAA	PCB, IO	RTL 1
E4	DL31U1634AAA	PCB, PAD	RTL 1
E5	DL32U1634AAA	PCB, SW	RTL 1
E6	DL33U1634AAA	PCB, LED-LEFT	RTL 1
E7	DL34U1634AAA	PCB, PR	RTL 1
E8	DL36U1634AAA	PCB, LED-RIGHT	RTL 1
E9	DL37U1634AAA	PCB, SD	RTL 1
E10	DL38U1634AAA	PCB, HSDPA	RTL 1
E11	DL39U1634AAA	PCB, POWERSW	RTL 1
E12	DL3UP1552AAA	PCB, EXT ANT UNIT	RTL 1
E13	DL31U1635AAA	PCB, BT	RTL 1
E14	DL3UP1566AAA	BAT FPC UNIT	1
E15	DL3U11553AAA	WWAN MAIN ANT	RTL 1
E16	DL3U21553AAA	WWAN AUX ANT	RTL 1
E17	DL3U31553AAA	LAN-MAIN BT ANT	RTL 1
E18	DL3U41553AAA	LAN AUX ANT	RTL 1
E19	DL3UP1605AAA	CF-19 TS PCB UNIT	RTL 1
E20	DFJS1060ZA	WWAN COAXIAL CABLE	1
E21	DFJS1117ZA	LCD CABLE TS	1
E22	 N0GB1J000019	INVERTER	1
E23	 N3CAYYY00030	HARD DISK	1
E24	N2AZZY000078	KEYBOARD VISTA, U.S.	1
E25	DFJS1120ZA	MODEM CABLE	1
E26	 N5HAZ0000014	MODEM	1
E27	N5ZZ00000128	DDR2-667 200PIN SO-DIMM, 1GB	1
E28	DFJS1059ZA	WLAN COAXIAL CABLE	1
E29	 N5HZC0000031	WIRELESS LAN MODULE	1
E30	D4CZY103A003	THERMISTOR	1
E31	DFJS1043ZA	POWER SW CABLE	1
E32	N2EABEC00006	TOUCHPAD	1
E33	BR-2330A/SF	LITHIUM COIN BATTERY	1
E34	DFJS1119ZA	LAN CABLE	1
E35	K1NB94B00001	EXPRESS PCMCIA COMBO SLOT	1
E36	DFWV08A0108	LCD UNIT ASS'Y	1
E36-1	DL3DW0186AAA	LCD ASS'Y	1
E36-1-1	A2CA00000056	LCD BACKLIGHT, CCFGL	1
E36-1-2	DFHM0290ZA	REFLECTION ANGLE	1
E36-1-3	DFHR3H12YA	LCD REFLECT TAPE	1
E36-2	DFHR3612ZA	LCD PWB SPACER	1
E36-3	DFHR3647YA	SPACER SHEET	2
E36-4	DFHR3D92YA	LCD BACK DAMPER	1
E36-5	DFHR3570YA	LCD BACK CUSHION	1
E36-6	DFHR3571YA	LCD BACK CUSHION S	2
E36-7	DXHM0042ZA	SCREW	2
E36-8	DFHR3648ZA	HOLDER SHEET B	2
E36-10	DFHR3B64ZA	LCD SIDE CUSHION A	2
E36-11	DFHR3506YA	LCD SIDE CUSHION C	2
E36-12	DFHR3507YA	LCD SIDE CUSHION D	1
E36-13	DFHR3G97ZA	LCD BACK SPACER TS	2
E36-14	DFHR3G99ZA	LCD REAR CUSHION F	2
E36-15	DFHR3H84ZA	LCD REAR CUSHION I	1
E36-16	DFMX0383TA	INSULATION PARTS	1
E401	DFUP1587ZA	FPC, AUDIO 40PIN	1
E402	DFUP1588ZA	FPC, IO 24PIN	1

E403	DFUP1644ZA	FPC, SD(19MK2 SD LAN 24PIN)		1
E404	DFUP1586ZA	FPC, HSDPA 50PIN		1
E405	DFUP1645ZA	FPC, BT(19MK2 BT FPC 10PIN)		1
E406	DFUP1589ZA	FPC, PAD 40PIN		1
E407	DFUP1591ZA	FPC, LED LEFT 10PIN		2
E409	DFUP1593ZA	FPC, LED RIGHT 6PIN		1
Accessories				
A1	△	NCR-B/603A	LITHIUM ION BATTERY PACK	1
A2	△	CF-AA1633AM1	AC ADAPTOR	1
A3	△	K2CG3DR00003	AC CORD	1
A4 (A)	△	DFQW5088ZA	OPERATING INSTRUCTIONS(CF-19MK2)	1
A4 (J)	△	DFQW5097ZA	MANUAL(CF-19MK2 VISTA)	1
A5		DFJS954ZA	MODEM CABLE	1
A6		DFHS9017ZA	TOUCHPANEL CLOTH	1
A7 (A)		DFQM8379MA	RECOVERY DVD, VISTA	1
A8		DFQC9006ZB-0	SHOULDER BELT ASS'Y	1
Packing Material				
P1		DFPE0733YA	HOLDER	1
P2		DFPE0859YA	HOLDER	1
P3		DFPK1210WA	PACKING CASE	1
P4		DFPK1216YA	ACCESSORY BOX	1
Mechanical Parts				
K1		DFHM9017ZA-0	EZC LID ASS'Y	1
K3		DFHR9125ZD-0	PALM REST ASS'Y	1
K3-1		DFHR3578ZA	PARMREST TAPE OUTSIDE	NRP
K3-2		DFHR3580YA	PARMREST TAPE RUBBER	NRP
K5		DFQC9009ZC-0	STRAP BG ASS'Y	1
K6	△	DFKE9059YA	LOCK PLATE ASS'Y	1
K7		DFBH3029UA	HINGE	1
K8		DFME0148YA	PEN TETHER	1
K9	△	DFKE9086ZA-0	HINGE TOP COVER ASM	1
K10	△	DFWV80A0401	LCD FRONT CABINET/TS PANEL ASS'Y	1
K10-1	△	DFKF9033VB-1	LCD FRONT CASE ASS'Y TS	1
K10-1-1		DFJS1064ZA	SPEAKER CABLE	1
K10-1-2		L0AA04C00012	SPEAKER	1
K10-1-3		DFHG1634YA-0	LCD CABINET CUSHION A	NRP
K10-1-4		DFHG1635ZA-0	LCD CABINET CUSHION B	NRP
K10-1-5		DFHM0319YA	LCD ELEPASS	2
K10-1-6		DFHM0321ZA	D WASHER	2
K10-1-7		DFHM0322ZA	SPRING WASHER	2
K10-1-8		DFHM0413ZA	SPEAKER PLATE	1
K10-1-9		DFHR3469ZA	PEN FRICTION SHEET	NRP
K10-1-10		DFHR3H08ZA	SPEAKER WP SHEET	NRP
K10-1-11		DFHR6282ZB	PEN HOLDER	1
K10-1-12	△	DFKM0521VA-1	FRONT CASE TS BLACK	1
K10-1-13		DRHM5025YAT	SCREW	4
K10-2		DFHE0805ZA	MAGNET	1
K10-3		DFHP7149ZA	MAGNET TAPE	NRP
K10-4		DFWV84A0308	TOUCH SCREEN PANEL KIT	1
K10-4-1		DL3DV0186AAA	TS PANEL ASS'Y	1
K10-4-1-1		DFHR9071ZA	PROTECTIVE FILM	1
K10-4-2		DFHR3630ZA	TS FPC SPACER	NRP
K10-4-3		DFHR3476ZA	TS SPACER A	NRP
K10-4-4		DFHR3477ZA	TS SPACER B	NRP
K10-4-5		DFHR3464WA	LCD SIDE CUSHION B TS	NRP
K11		DFWV80C0532	LCD REAR CABINET ASS'Y	1
K11-1	△	DFKM9039YA-0	REAR CASE ASS'Y	1
K11-1-1		DFHG1634YA-0	LCD CABINET CUSHION A	NRP
K11-1-2		DFHG1635ZA-0	LCD CABINET CUSHION B	NRP
K11-1-3		DFHM0319YA	LCD ELEPASS	2
K11-1-4		DFHM0321ZA	D WASHER	2
K11-1-5		DFHM0322ZA	SPRING WASHER	2
K11-1-6	△	DFKM0522YA-0	REAR CASE	1
K11-2		DFHR3J19ZA	LCD REAR CUSHION J	NRP
K11-3		DFHR3460YA	LCD REAR CUSHION A	NRP
K11-4		DFHR3567YA	LCD REAR CUSHION G	NRP

K11-6		DFHR3563YA	LCD REAR CUSHION C	NRP	1
K11-7		DFHR3564YA	LCD REAR CUSHION D	NRP	1
K11-8		DFHR3565YA	LCD REAR CUSHION E	NRP	2
K11-9		DFGB0165YA-0	TOUGHBOOK BADGE NEW	NRP	1
K11-10		DFGB0131YA-0	PANASONIC BADGE		1
K12	⚠	DFKM9040WA-0	TOP CASE ASS'Y		1
K12-1		DFHM0320YA	TOP ELEPASS		2
K12-2		DFHR3434ZA	AUDIO WATERPROOF SHEET	NRP	1
K12-3		DFHR3440ZA	DSUB WATERPROOF SHEET	NRP	2
K12-4		DFHR3470YA	PSW WATERPROOF SHEET	NRP	1
K12-5		DFHR3D86ZA	FS CASE WP SHEET	NRP	1
K12-6		DFHR3D94YA	GPS HOLE SHEET A	NRP	1
K12-7		DFHR3E15ZA	LAN WP SHEET	NRP	1
K12-8		DFHR3E16ZA	MODEM WP SHEET	NRP	1
K12-9		DFHR3F00ZA	1394 WP SHEET	NRP	1
K12-10		DFHR3F01ZA	USB BACK WP SHEET	NRP	2
K12-11		DFHR6276ZA-0	POWER SW KNOB		1
K12-12	⚠	DFKM0519WA-0	TOP CASE		1
K12-13	⚠	DFKE9089YA-0	BAT LID ASS'Y		1
K12-13-1		DFBH3030ZA	LID HINGE		2
K12-13-2		DFHM0315YC	LATCH PLATE BATTERY		1
K12-13-3		DFHR3466YA	LID KNOB SHEET	NRP	1
K12-13-4		DFHR3509YA	BAT COVER SHEET	NRP	1
K12-13-5	⚠	DFKE0889ZA-0	LID KNOB		1
K12-13-6	⚠	DFKE0891ZA-0	BAT LID		1
K12-13-7		DFUN0068XA	LID KNOB SPRING		1
K12-13-8		DFUS0323ZA	LID KNOB SPRING PLATE		1
K12-13-9		DRHM0109ZAT	SCREW		2
K12-13-10		DRQT26+D3KLT	SCREW		2
K12-13-11		DXQT2+F3FNLT	SCREW		1
K12-14	⚠	DFKE9090XA-0	HDD LID ASS'Y		1
K12-14-1		DFBH3030ZA	LID HINGE		2
K12-14-2		DFHM0285XC	LID LATCH PLATE		1
K12-14-3		DFHR3466YA	LID KNOB SHEET	NRP	1
K12-14-4		DFHR3508YA-0	HDD COVER SHEET	NRP	1
K12-14-5	⚠	DFKE0889ZA-0	LID KNOB		1
K12-14-6	⚠	DFKE0890ZA-0	HDD LID		1
K12-14-7		DFUN0068XA	LID KNOB SPRING		1
K12-14-8		DFUS0323ZA	LID KNOB SPRING PLATE		1
K12-14-9		DRHM0109ZAT	SCREW		2
K12-14-10		DRQT26+D3KLT	SCREW		2
K12-14-11		DRHM5025YAT	SCREW		1
K12-14-12		DFHR6218YA	SPACER		2
K12-15	⚠	DFKE9091YA-0	PCMCIA LID ASS'Y		1
K12-15-1		DFBH3030ZA	LID HINGE		2
K12-15-2		DFHM0285XC	LID LATCH PLATE		1
K12-15-3		DFHR3466YA	LID KNOB SHEET	NRP	1
K12-15-4		DFHR3588RA-0	PCMCIA LID SHEET	NRP	1
K12-15-5	⚠	DFKE0889ZA-0	LID KNOB		1
K12-15-6	⚠	DFKE0890ZA-0	HDD LID		1
K12-15-7		DFUN0068XA	LID KNOB SPRING		1
K12-15-8		DFUS0323ZA	LID KNOB SPRING PLATE		1
K12-15-9		DRHM0109ZAT	SCREW		2
K12-15-10		DRHM5025YAT	SCREW		1
K12-15-11		DRQT26+D3KLT	SCREW		2
K12-15-12		DFHR6218YA	SPACER		2
K12-16		DRQT26+D3KLT	SCREW		6
K12-17		DXQT3+F4FNLT	SCREW		2
K13	⚠	DFKE9092YA-0	TABLET LATCH ASS'Y		1
K13-1		DFHG1669ZA	TABLET LATCH SHEET	NRP	1
K13-2		DFHM0291ZA	TABLET LATCH PLATE		1
K13-3		DFHM0294WA	TABLET LATCH PIN		2
K13-4		DFHM0295ZA	TABLET LATCH SHAFT		1
K13-5	⚠	DFKE0892ZA-0	TABLET LATCH KNOB		1
K13-6	⚠	DFKE0893YA-0	TABLET LATCH LEVER		1
K13-7		DFNW1604ZA	CUT WASHER		1

K13-8		DFUN0069XA	LATCH KNOB SPRING		1
K14	△	DFKM9041XA-0	BOTTOM CASE ASS'Y		1
K14-1		DFHM9016ZA-0	DIMM LID ASS'Y		1
K14-1-1		DFHM0401ZA-0	DIMM LID		1
K14-1-2		DFHR3E14ZA	DIMM LID WP SHEET	NRP	1
K14-2		DFHM0410YA	DU LID ANGLE		1
K14-3		DFHR3441ZA	DU LID WATERPROOF SHEET	NRP	1
K14-4		DFHR3F64ZA	HDD BOTTOM SHEET		2
K14-5		DFHR6283ZB-0	DU LID		1
K14-6	△	DFKM0518XA-0	BOTTOM CASE		1
K14-7		DFUS0316ZA	PLATE SPRING GUIDE PIN		2
K14-8		DRHM5025YAT	SCREW		6
K14-9		DXQT2+D25FNL	SCREW		7
K15		DFHE1019YA	DU CON SPONGE		1
K16		DFHG1209ZA	RUBBER HOOT		4
K17		DFHG1996ZA-0	SERIAL LID RUBBER		1
K18		DFHG1638ZB-0	MODEM LID RUBBER		1
K19		DFHG1998ZA-0	USB LID RUBBER		1
K20		DFHG1997ZA-0	RGB LID RUBBER		1
K21		DFHG1660ZB-0	LAN LID RUBBER		1
K22		DFHG1790ZA	BAT CUSHION		1
K23		DFHG1902ZA-0	DC-IN LID RUBBER		1
K24		DFHG1903ZB-0	1394 LID RUBBER		1
K25		DFHG1906ZA-0	AUDIO LID RUBBER		1
K26		DFHG1907YB-0	USB LID RUBBER 2		1
K27		DFHM0286YB	LID RUBBER PLATE A		1
K28		DFHM0288ZB	LID RUBBER PLATE C		2
K29		DFHM0296XA-0	LCD HINGE COVER(SILVER)		1
K30		DFHM0302XA-1	KEYBOARD PLATE(L)		1
K31		DFHM0303XA-0	KEYBOARD PLATE(R)		1
K32		DFHM0311ZB	LID RUBBER PLATE B		2
K33		DFHM0403XA	DU CNT ANGLE		1
K34		DFHM0406ZA	KBD CNT LID		1
K35		DFHM0407ZA	BAT CON ANGLE		1
K37		DFHR3487YA	PORTRE SHEET	NRP	1
K38		DFHR3636ZA	CABLE HOLD SHEET	NRP	1
K39		DFHR3D91ZA	KB CNT LID WP SHEET	NRP	1
K40		DFHR3E03ZA	SD BLIND SHEET	NRP	1
K41		DFHR3E53ZA	FS SCREW SHEET	NRP	1
K42		DFHR3F62ZA	POWER SWITCH CABLE SHEET	NRP	1
K43		DFHR3G19ZA	INSULATION SHEET	NRP	2
K45		DFHR6246ZA	HDD GUIDE		1
K46		DFHR6284ZA	DIMM HOLDER		1
K47		DFHR6286ZA-0	RF SW KNOB		1
K48		DFHR6289YA	BAT CON HOLDER		1
K49		DFHR6290ZA-0	FS DUMMY CASE		1
K50		DFHR6312ZA	ANT CABLE HOLDER		1
K51		DFHR7946ZA	MP GUIDE SHEET	NRP	1
K52		DFHR9081ZA	PEN		1
K53		DFMC0870YA	DU SPRING		1
K54		DFMX0383TA	INSULATION PARTS		9
K55		DFMY0419ZA	DIMM THERMAL RUBBER		1
K57		DFHE0915ZA	EMI SHEET 10X20	NRP	1
K58		DFHM0325ZA	CABLE HOLD PLATE		2
K59		DFHR3432ZA	ANT CABLE CUSHION	NRP	4
K61		DFHR3573YA	LCD SIDE CUSHION E	NRP	2
K62		DFHR3574YA	LCD SIDE CUSHION F	NRP	1
K63		DFHR3638XA	DG TAPE		1
K65		DFHR3G16ZA	INSULATION SHEET 30X140	NRP	1
K66		DFHR3G42ZA	TAPE PEN HOLDER		2
K67		DFHR6277ZA-0	CABLE HOLDER		2
K68		DFHR6320ZA-0	ANT COVER		2
K69		DFHR6279YA-0	TABLET LATCH COVER		1
K70		DFHR6298ZA	HINGE CABLE HOLDER		1
K71		DFMC0685ZA	LCD CONDUCTIVE TAPE	NRP	1
K72		DFMC0816ZA	INV MIL SHEET		1

K73	DFMC0877YA	INVERTER CASE		1
K74	DFMC0878ZA	INVERTER SHIELD SHEET	NRP	1
K76	DFMX1267ZA	INVERTER CASE(BASE)		1
K77	DFMX1268ZA	INVERTER CASE(LOWER)		1
K78	DFQT6077YA	CAUTION LABEL		1
K79	DFUQ0100ZA	LOCK SPRING		2
K80	DFWV99A0124	HDD MOUNTING KIT		1
K80-1	DFHM0404ZB	HDD CASE UPPER		1
K80-2	DFHM0416YA	HDD CASE LOWER		1
K80-3	DFHR3589ZA	HDD CASE TAB		1
K80-4	DFHR3H58ZA	HDD DAMPER		1
K80-5	DFHR3F54ZA	HDD CON SHEET		1
K80-6	DFHR6297ZA	HDD CONNECTOR GUARD		1
K80-7	DL3UP1564CAA	HDD FPC UNIT		1
K80-8	DFMX0383TA	INSULATION PARTS	NRP	2
K80-9	DFMX1265ZA	INSULATION SHEET(HDD HEATER)	NRP	1
K80-10	DFMY3208ZA	WLAN SHEET	NRP	1
K80-11	⚠ L9DZYY000008	HEATER(HDD)		1
K80-12	DXQT2+D4FNL	SCREW		2
K81	DFQT0045ZA	ENERGY STAR LABEL		1
K82	DFQT9A29ZA	WINDOWS VISTA		1
K83	DFQT9981ZA	CENTRINO DUO LABEL		1
K84	DFQT0055YA	COA SERIAL LAMINATE	NRP	1
K85	⚠ DFGT1094YA	RATED LABEL		1
K86	DFHD04H004YB	HEXAGON SPACER H=4.2MM		2
K87	DFHR3F85ZA	MODEM CABLE SHEET	NRP	1
K88	DFMC0881ZA	BUSTERAID MODEM	NRP	2
K90	DFHM0309YA-1	SIM LOCK PLATE		1
K91	DFHR3G18ZA	BIS HEAD SHEET	NRP	1
K92	DFHR3G24ZA	BIS HEAD SHEET 2	NRP	1
K93	DFMY3224ZA	WLAN SHEET	NRP	1
K94	DFHM0412ZA	RF-BT PLATE		1
K95	DFHR3154ZA	LCD CABLE TAPE	NRP	1
K96	DFHR5484ZA	CLAMP		1
K98	DFHE0326XA	GASKET-65TSV10-4-15		1
K99	DFHE0811YA	GASKET-65TSV4-3-50		1
K100	DFHE1031ZA	GASKET-65TSV13-1.5-20		1
K101	DFHG1962ZA	POWER SPRING SHEET	NRP	1
K102	DFHP7200ZA	AHDESIVE TAPE	NRP	1
K103	DFHP7256ZB	RF LED PWB TAPE	NRP	1
K104	DFHP7257ZB	LED PWB TAPE	NRP	1
K107	DFHR3438ZA	CLICK BUTTON SHEET	NRP	1
K108	DFHR3483SA	OPERATION SHEET		1
K109	DFHR3J80ZA	KB WP SHEET	NRP	1
K110	DFHR3642YA	LCD CUSHION SHEET	NRP	2
K111	DFHR3643ZA	TP BOTTOM TAPE	NRP	1
K112	DFHR3655YA	HDD CASE SPACER		2
K113	DFHR3D90ZA	KB CNT HOLE CUSHION	NRP	1
K114	DFHR3D93ZB	TP WP SHEET	NRP	1
K115	DFHR3D97ZA	LED PWB TAPE	NRP	1
K116	DFHR3E02ZA	PALM REST WP SHEET R	NRP	1
K117	DFHR3E19ZA	LED SYAKOU SHEET	NRP	1
K118	DFHR3E34ZA	RF SYAKOU SHEET	NRP	1
K120	DFHR3F55ZA	OPERATION TAPE	NRP	1
K121	DFHR3F65ZA	PC SHEET	NRP	2
K122	DFHR3F66ZB	PET SHEET	NRP	2
K124	DFHR6044XA	CLICK BUTTON PLATE		1
K126	DFMD2182ZA	PLATE HEAT PIPE		1
K127	DFMD3125ZA	BACK PLATE KENSINGTON 2		1
K129	DFMY0278YA	THERMAL SHEET	NRP	1
K130	DFMY0473ZA	CPU HEAT PIPU RUBBER	NRP	2
K131	DFMY3208ZA	WLAN SHEET	NRP	1
K132	DFMY5039ZA	HEAT PIPE UNIT		1
K133	DFUQ0111ZA	POWER SW SPRING		1
K137	DFMY3234ZA	THERMAL DIFFUSION SHEET	NRP	1
K140	DFHR3488ZA	ANTENNA SHEET	NRP	1

K141	DFHG429YA	IO DC TUBE		1
K142	DFHR3G38ZA	DIMM CUSHION		3
K144	DFHP7270ZA	ADHESIVE TAPE	NRP	4
K157	DFMX1339ZA	BAT INSULATION SHEET	NRP	1
K158	DFHR3J82ZA	LCD CABLE PROTECTOR		1
K159	DFHR6352ZA	CABLE GUIDE HINGE		1
K160	DFHR3F89ZA	MCH SHEET	NRP	1
K161	DFHR3H64ZA	COIN BAT SHEET	NRP	1
K162	DFHR6353ZA	LAN CONN HOLDER		1
K163	DFMC0901ZA	GASKET-65TSV13-1(T9)-1.9		1
K164	DFMY0472ZA	THERMAL RUBBER CPU		1
K165	DFMY0475ZA	ICH RUBBER		2
K166	DFHR3650ZA	WATERPROOF SHEET	NRP	1
K167	DFHR3H95ZA	LCD TS PWB SHEET	NRP	1
K1051	DFMY3264YA	DIMM THERMAL SHEET	NRP	1
K1603	DFHR6339ZA-0	DUMMY EXPRESS CARD		1
K1604	DFHR6340ZA-0	DUMMY PC CARD		1
K1610	DFHR3J11ZA	PCMCIA DUMMY CARD CUSHION		1
N1	DFHE5025XA	SCREW		33
N2	DFHE5058ZB	SCREW		4
N3	DFHE5108ZA	SCREW		4
N4	DRHM0112ZA	SCREW		2
N5	DRHM0115ZA	SCREW		2
N6	DRHM5025YA	SCREW		18
N7	DRQT26+E5FKL	SCREW		18
N8	DRSB2+10FKL	SCREW		2
N9	DRSB2+5FKL	SCREW		27
N10	DRHM0061ZA	SCREW		13
N11	DRYN3+J6FKL	SCREW		2
N14	DRQT3+E4FKL	SCREW		2
N15	DXYN2+J6FNL	SCREW		10
N16	DXYN3+J10FNL	SCREW		2
N17	DXYN3+J8FNL	SCREW		2
N18	DXYN4+J8FNL	SCREW		4
N19	XSB2+3FNL	SCREW		17

Replacement Parts List

Note: Important Safety Notice

Components identified by  mark have special characteristics important for safety.

When replacing any of these components use only manufacturer's specified parts.

CF-19FHGAXxM

REF. NO and AREA	PART NO.	DESCRIPTION	Q'TY
MAIN PCB			
C 1, 135, 136, 137, 197, 198, 268, 279, 281, 328, 376	F1J0J4750019	CAPACITOR, 6.3V, 4.7μF	11
C 2, 3, 4, 5, 6, 9, 50, 51, 55, 56, 57, 61, 62, 63, 64, 65, 66, 67, 68, 69, 70, 71, 72, 73, 74, 75, 76, 77, 152, 153, 154, 155, 159, 161, 163, 165, 168, 169, 170, 171, 174, 176, 178, 180, 185, 187, 190, 205, 206, 230, 231, 232, 233, 234, 235, 237, 238, 239, 240, 241, 242, 243, 244, 245, 246, 272, 282, 283, 289, 290, 300, 301, 302, 309, 313, 314, 316, 317, 318, 320, 323, 327, 334, 346, 351, 356, 375, 393, 394, 396, 397, 398, 399, 400, 401, 403, 404, 405, 406, 407, 408, 409, 410, 411, 412, 413, 415, 416, 417, 418, 419, 420, 421, 424, 428, 429, 432, 439, 450, 451, 453, 454, 459, 460, 461, 462, 463, 470, 471, 472, 488, 490, 500, 501, 502, 503, 507, 508, 510, 512, 513, 514, 516, 520, 521, 522, 523, 524, 601, 607, 642, 646, 656, 698	F1G1C104A042	CAPACITOR, 16V, 0.1μF	154
C 10, 11, 12, 13, 14, 15, 16, 17, 18, 19, 20, 21, 22, 23, 24, 25, 26, 27, 28, 29, 30, 31, 32, 33, 34, 35, 36, 37, 38, 39, 40, 41, 45, 84, 85, 86, 87, 88, 89, 90, 91, 92, 93, 94, 95, 96, 158, 160, 162, 164, 173, 175, 177, 179, 186, 189, 249, 250, 251, 252, 253, 254, 288, 319, 344, 345, 347, 370, 371, 372, 378, 379, 380, 381, 437, 473, 511, 515, 723, 742, 743	F1J0J106A016	CAPACITOR, 6.3V, 10μF	81
C 42, 78, 79, 80, 81, 83, 247, 248	EEFCX0D221R	CAPACITOR, 2V, 220μF	8
C 46, 306, 307, 325, 422, 431, 433, 489, 491, 492, 616, 628, 631, 635, 653, 655, 657, 669, 686, 688, 693, 706, 713, 754, 755, 756, 757, 758	F1G1H102A496	CAPACITOR, 50V, 1000pF	28
C 58, 59, 138, 139, 140, 141, 142, 143, 144, 145, 150, 157, 166, 181, 199, 200, 201, 202, 203, 204, 269, 270, 271, 388, 509	F1H0J1050022	CAPACITOR, 6.3V, 1μF	25

C 97, 255, 256, 315, 321, 336, 337, 340, 341, 342, 343, 386, 387, 389, 390, 525, 603, 726, 740, 751, 768	F1H1A1050015	CAPACITOR, 10V, 1µF	21
C 98, 99, 100, 101, 102, 103, 104	F1G0J474A001	CAPACITOR, 6.3V, 0.47µF	7
C 105, 106, 107, 108, 109, 110, 111, 112, 258	F1J0J226A051	CAPACITOR, 6.3V, 22µF	9
C 113, 114, 115, 191, 192, 193, 194, 259, 260, 261, 262, 263, 276, 277, 278, 293, 303, 304, 305, 308, 312, 326, 332, 350, 373, 374, 438, 485, 600, 615, 626, 636, 640, 720	F1G1E103A062	CAPACITOR, 25V, 0.01µF	34
C 116, 117, 118, 119, 120, 121, 122, 123	F1G0J224A001	CAPACITOR, 6.3V, 0.22µF	8
C 124	F1G1H330A542	CAPACITOR, 50V, 33pF	1
C 126, 127, 128, 129, 130, 131, 132, 133, 236, 265, 266, 267	F1G0J105A001	CAPACITOR, 6.3V, 1µF	12
C 195, 196	F1G1H150A542	CAPACITOR, 50V, 15pF	2
C 211, 222, 223, 224, 225, 226, 227, 228, 383, 384, 385, 425, 426, 427	F1G1A104A014	CAPACITOR, 10V, 0.1µF	14
C 257, 264	F1G1H3R0A543	CAPACITOR, 50V, 3pF	2
C 273	EEFCX0J121R	CAPACITOR	1
C 329, 330	F1G1H120A542	CAPACITOR, 50V, 12pF	2
C 331, 671	F1J1E334A081	CAPACITOR, 25V, 0.33µF	2
C 333	F1G1H271A495	CAPACITOR, 50V, 270pF	1
C 348, 349, 630, 651, 684, 695, 703, 709	F1G1H221A495	CAPACITOR, 50V, 220pF	8
C 382, 643, 644, 645	F1G1C473A004	CAPACITOR, 16V, 0.047µF	4
C 391, 392	F1G1H4R0A543	CAPACITOR, 50V, 4pF	2
C 423	F1G1E472A062	CAPACITOR, 25V, 4700pF	1
C 435, 606, 627, 634, 658, 685, 692, 702, 705, 725, 765, 767, 769, 770	F1H1H104A748	CAPACITOR, 50V, 0.1µF	14
C 455, 456, 457, 458, 604	F1J1E105A009	CAPACITOR, 25V, 1µF	5
C 484, 487	F1G1A683A014	CAPACITOR, 10V, 0.068µF	2
C 506, 624, 650, 687, 715, 749	F1G1H1010005	CAPACITOR, 50V, 100pF	6
C 609, 610, 611, 612, 613, 614	F1H1H103A748	CAPACITOR, 50V, 0.01µF	6
C 620, 621	EEFCX0J101R	CAPACITOR, 6.3V, 100µF	2
C 623, 638, 662, 663, 674, 696, 701, 716, 746, 772, 773, 775, 776, 777, 778, 779, 782, 783, 784, 785	F1K1E1060001	CAPACITOR, 25V, 10µF	20
C 625, 682, 712, 759	F1H1C224A074	CAPACITOR, 16V, 0.22µF	4
C 629, 632, 637, 690, 710	F1G1H220A542	CAPACITOR, 50V, 22pF	5
C 633, 654, 660, 691, 711	F1J0J475A009	CAPACITOR, 6.3V, 4.7µF	5
C 639	EEFCX0G151R	CAPACITOR, 2V, 150µF	1
C 647	EEFCD0J470ER	CAPACITOR, 6.3V, 47µF	1
C 652, 760	F1G1H561A496	CAPACITOR, 50V, 560pF	2
C 659	F1H1H222A748	CAPACITOR, 50V, 2200pF	1
C 661, 744	F1G1H470A542	CAPACITOR, 50V, 47pF	2
C 664, 665, 672, 747	EEFSX0D471XE	SPCAP	4
C 668, 761	F1G1H151A495	CAPACITOR, 50V, 150pF	2
C 670, 745	F1G1H331A496	CAPACITOR, 50V, 330pF	2
C 673, 752	F1H1H1830001	CAPACITOR, 50V, 0.018µF	2
C 680, 697, 700, 724	EEFCD0D101ER	CAPACITOR, 2V, 100µF	4
C 683, 714	F1G1H472A496	CAPACITOR, 50V, 4700pF	2
C 689, 708	F1G1H471A496	CAPACITOR, 50V, 470pF	2
C 694, 704	F1G1H182A496	CAPACITOR, 50V, 1800pF	2
C 707	F1G1H100A544	CAPACITOR, 50V, 10pF	1
C 717	EEFSX0D331ER	CAPACITOR, 2V, 330µF	1
C 753	F1G1H222A496	CAPACITOR, 50V, 2200pF	1

C 766		F1G1H152A496	CAPACITOR, 50V, 1500pF	1
CF 1, 2, 3		D4CC1103A038	THERMISTOR	3
CN 2		K1MYL0B00003	CONNECTOR	1
CN 4		K1NAF0D00003	CONNECTOR	1
CN 5		K1KY42B00001	CONNECTOR	1
CN 6		K1FY104BA024	CONNECTOR, USB	1
CN 8		K1KA20AA0261	CONNECTOR	1
CN 9, 21, 42		K1MY24BA0310	CONNECTOR	3
CN 10		K1MYL0B00004	CONNECTOR	1
CN 11		K1MY52BA0190	CONNECTOR	1
CN 14		K1KA02B00292	CONNECTOR	1
CN 15		K1MY30AA0158	FPC CONNECTOR	1
CN 16		K1MN50AA0018	CONNECTOR	1
CN 17		K1KA20A00310	CONNECTOR	1
CN 18		K1MN26AA0074	CONNECTOR	1
CN 20		K1MY04AA0041	CONNECTOR	1
CN 22		K2HZ104B0014	CONNECTOR	1
CN 23		K1MY40A00001	CONNECTOR	1
CN 24		K1KY12A00005	CONNECTOR	1
CN 25		K1KYA0A00019	CONNECTOR	1
CN 27		K1MN40B00048	CONNECTOR	1
CN 33		K1KA02BA0014	CONNECTOR	1
D 2, 3, 8		MA2J72900L	DIODE	3
D 4		BOJDBE000002	DIODE	1
D 5, 600		BOJCPD000023	DIODE	2
D 6		BOKB00000044	DIODE	1
D 9, 10, 11		MA3J14700L	DIODE	3
D 601, 602, 603		BOADDH000004	DIODE	3
D 604		MAZ81200ML	DIODE	1
D 605		MAZ81800ML	DIODE	1
D 606, 622		MA3S132E0L	DIODE	2
D 608		BOJCQD000001	DIODE	1
D 609, 626, 631		BOJCMD000010	DIODE	3
D 610, 627, 630		BOJDAE000004	DIODE	3
D 612, 613, 614, 615, 617, 618, 623		MAZ80510ML	DIODE	7
D 616		MAZ80620ML	DIODE	1
D 619, 621		MA2S11100L	DIODE	2
D 620		B2ABAM000002	DIODE	1
D 624		BOJCRC000002	DIODE	1
D 632, 635		BOJCMD000014	DIODE	2
F 1	⚠	K5H502Z00003	FUSE, 5A, 32V	1
F 2, 3, 4, 5, 8	⚠	K5H202Z00005	FUSE, 2A, 32V	5
F 10	⚠	K5H802300002	FUSE, 8A, 72V	1
F 600	⚠	K5H103300003	FUSE, 10A, 72V	1
IC 1		C2GBD0000037	CPU	1
IC 2		C1CB00002802	CHIPSET	1
IC 3		COJBBZ000319	PLL	1
IC 4		C1CB00002741	CHIPSET ICH8M	1
IC 5		C1CB00002585	IC	1
IC 6		C1CB00002732	LAN CONTROLLER	1
IC 7		C3EBFY000002	SERIAL EEPROM	1
IC 8		C1DB00001159	IC, PERIPHERAL LSI	1
IC 9		COCBCBC00137	IC, REGULATOR	1
IC 10		C1CB00002540	IC, TEMPERATURE SENSOR IC	1
IC 11		CODBZYY00017	IC	1
IC 12, 19		CODBZYY00026	IC, USB POWER SW	2
IC 14		CODBZYY00265	POWER MANAGEMENT SWITCH	1
IC 15		C3EBDY000005	IC, EEPROM	1
IC 16		CODBZYY00016	IC	1
IC 18, 32, 34, 35		COJBAZ002422	IC, FET SWITCH	4
IC 20		COZBZ0000978	IC	1
IC 21, 22		COJBAS000218	IC, LOGIC	2

IC 23, 24, 25, 71		C0EBE0000460	IC	4
IC 26		C0EBH0000457	IC	1
IC 27		C2CBJA000003	IC, MICON	1
IC 30		C3FBLY000048	FLASH MEMORY	1
IC 31		C1CB00002790	IC, SECURITY CHIP	1
IC 33, 51, 52		C0JBAA000345	IC, LOGIC	3
IC 41		C0JBAA000380	IC	1
IC 42		C1CB00002723	CARDBUS CONTOLLER	1
IC 46, 55, 56, 57, 59, 67,		C0JBAA000362	IC, LOGIC	7
IC 50		C0JBAZ002192	IC	1
IC 53		C0JBAC000363	GATE LOGIC	1
IC 54		C0JBAC000367	IC, LOGIC	1
IC 58		C0JBAE000321	IC, LOGIC	1
IC 60		C0DBAYY00282	DC/DC CONTROLLER FOR GMCH	1
IC 65		C0DBGYY00422	LINEAR REGULATOR	1
IC 66		C0DBGYY00423	LINEAR REGULATOR	1
IC 68		C0JBAR000500	IC, SWITCH	1
IC 70		C0DBEFE00003	IC	1
IC 600		C0ABZA000047	IC, AMP	1
IC 601		C0ABBA000093	IC, OP AMP	1
IC 602		C0DBAYY00194	IC, DC/DC	1
IC 603		C0JBAD000236	IC, LOGIC	1
IC 604		C0JBAB000621	IC, LOGIC	1
IC 605		C0DBEFH00002	IC, REGULATOR	1
IC 607		C0EBE0000333	IC	1
IC 608		C0DBDJH00009	IC, LINER	1
IC 610, 611, 612		C0DBALH00003	IC	3
L 4, 5, 6, 9, 10, 11, 12, 13, 29, 53		J0JJC0000021	INDUCTOR	10
L 7, 17, 40, 41, 47, 48, 51, 52, 60, 61		J0MAB0000200	INDUCTOR	10
L 14		G1C91NM00001	INDUCTOR	1
L 15, 16		G1C1R0Z00002	INDUCTOR	2
L 20, 21, 22, 23, 24, 25		J0JDC0000044	CHIP BEADS	6
L 28		G1C100K00011	INDUCTOR	1
L 30, 31		G1C1R0MA0076	INDUCTOR	2
L 35, 36, 49		J0JHC0000074	INDUCTOR	3
L 42, 43, 44		J0JDC0000045	INDUCTOR	3
L 50		J0JDC0000105	CHIP BEADS	1
L 600		G1C4R7MA0240	CHOK COIL	1
L 601, 604		G1C100Z00023	COIL	2
L 602		G1CR60MA0299	COIL	1
L 603		G1C2R7Z00003	COIL	1
L 605, 606		G1C4R7Z00013	INDUCTOR	2
L 609		G1CR82M00006	COIL	1
L 610		G1A160HA0032	COIL	1
PA 2	⚠	D4FB1R100015	PROTECTOR 1.1A	1
Q 1, 2, 646, 657, 659, 661		B1CFGD000023	TRANSISTOR	6
Q 3, 6, 13, 20, 29, 40, 608, 619, 641, 643, 649, 655, 656		B1GBCFJN0037	TRANSISTOR	13
Q 4, 39, 620		B1GDCFNN0031	TRANSISTOR	3
Q 5, 8, 28		B1MBDCA00004	TRANSISTOR	3
Q 9, 10, 11, 21, 26, 31, 33, 630		B1DHDC000028	TRANSISTOR	8
Q 12, 14, 15, 17, 18, 19		B1MBBCA00003	TRANSISTOR	6
Q 22, 24, 36, 37, 610, 621, 631		B1GBCFNN0042	TRANSISTOR	7
Q 25, 32, 623, 624, 625, 626, 628, 629		XP0421300L	TRANSISTOR	8
Q 27		B1GFCFNN0019	TRANSISTOR	1
Q 30, 603, 604, 606, 607		B1CHR0000001	TRANSISTOR	5
Q 34, 35		B1CFFB000001	TRANSISTOR	2
Q 51		2SB0766ARL	TRANSISTOR	1
Q 600, 601, 602		XP0421400L	TRANSISTOR	3

Q 611, 639, 650	B1CFGD000003	TRANSISTOR	3
Q 613, 618, 633, 636, 638, 642, 647, 648, 652, 653, 660	B1CFRD000014	FET	11
Q 614, 640, 645	B1MBEDG00001	FET	3
Q 622, 627	B1CHRC000009	FET	2
Q 634, 635	B1CFRD000025	FET	2
Q 658	B1MBEDA00008	TRANSISTOR	1
R 3, 5, 20, 52, 53, 56, 192, 213, 214, 215, 216, 231, 232, 274, 366, 434, 480, 481	ERJ2GEJ102X	RESISTOR, 1/16W, 1K Ω	18
R 7, 21, 22, 32, 41, 158, 199, 210, 234, 239, 241, 317, 331, 370, 396, 492, 499, 604, 625, 692, 693, 707, 711, 715, 717, 720, 732, 814, 840, 841	ERJ2GE0R00X	RESISTOR, 1/16W, 0 Ω	30
R 8, 33, 73, 74, 75, 695, 703, 797, 798	ERJ2RKF1001X	RESISTOR, 1/16W, 1K Ω	9
R 9, 10, 34, 35	ERJ2RKF54R9X	RESISTOR, 1/16W, 54.9 Ω	4
R 11, 12, 37, 95, 96	ERJ2RKF1000X	RESISTOR, 1/16W, 100 Ω	5
R 13, 39	ERJ2RKF2001X	RESISTOR, 1/16W, 2K Ω	2
R 14	D1H85104A024	RESISTOR ARRAY	1
R 15, 16	ERJ2RKF27R4X	RESISTOR, 1/16W, 27.4 Ω	2
R 24, 609, 612, 613, 824	ERJ2GEJ562X	RESISTOR, 1/16W, 5.6K Ω	5
R 25, 26	ERJ2GEJ560X	RESISTOR, 1/16W, 56 Ω	2
R 27, 157, 324, 638, 639, 651, 652, 734, 735, 745, 746, 762, 763, 774, 775	ERJ2GEJ100X	RESISTOR, 1/16W, 10 Ω	15
R 28	ERJ2RKF56R0X	RESISTOR, 1/16W, 56 Ω	1
R 29	ERJ2RKF68R0X	RESISTOR, 1/16W, 68 Ω	1
R 30	ERJ2GEJ240X	RESISTOR, 1/16W, 24 Ω	1
R 36, 72, 180, 225	ERJ2RKF24R9X	RESISTOR, 1/16W, 24.9 Ω	4
R 38	ERJ2RKF2210X	RESISTOR, 1/16W, 221 Ω	1
R 40, 154, 155, 156, 486, 504, 505	D1H81034A024	RESISTOR ARRAY	7
R 61, 226	ERJ2GEJ203X	RESISTOR, 1/16W, 20K Ω	2
R 65, 66, 450, 451	ERJ2GEJ222X	RESISTOR, 1/16W, 2.2K Ω	4
R 67, 68, 177, 369, 520, 523, 530	ERJ2GEJ330X	RESISTOR, 1/16W, 33 Ω	7
R 69	ERJ2RHD3001X	RESISTOR, 1/16W, 3K Ω	1
R 70, 71	ERJ2RKF20R0X	RESISTOR, 1/16W, 20 Ω	2
R 76, 77, 325, 497	ERJ2RKF1002X	RESISTOR, 1/16W, 10K Ω	4
R 78	ERJ2RKF1301X	RESISTOR, 1/16W, 1.3K Ω	1
R 82	ERJ2RKF2371X	RESISTOR, 1/16W, 2370 Ω	1
R 83	ERJ2RKF3920X	RESISTOR, 1/16W, 392 Ω	1
R 90, 91, 150, 153, 174, 175, 204, 220, 261, 280, 289, 290, 291, 297, 298, 302, 316, 319, 322, 323, 335, 336, 365, 367, 388, 389, 452, 453, 454, 473, 474, 489, 498, 507, 521, 525, 527, 529, 531, 533, 615, 641, 646, 713, 733, 737, 741, 765, 771, 805, 820	ERJ2GEJ103X	RESISTOR, 1/16W, 10K Ω	51
R 92, 93, 94, 337, 721, 722, 789, 791	ERJ3GEY0R00V	RESISTOR, 1/16W, 0 Ω	8
R 97, 98, 99, 247, 248, 249	ERJ2GEJ1R0X	RESISTOR, 1/16W, 1 Ω	6
R 100, 101, 103, 130, 131, 133	D1HA56080001	RESISTOR ARRAY	6
R 102, 132, 333	D1H85604A024	RESISTOR ARRAY	3
R 135	ERJ6GEYJ101V	RESISTOR, 1/10W, 100 Ω	1
R 159, 160, 242, 243	D1H83304A024	RESISTOR ARRAY	4
R 171	ERJ2RKF22R6X	RESISTOR, 1/16W, 22.6 Ω	1
R 172, 173	ERJ2RKF3241X	RESISTOR, 1/16W, 3240 Ω	2

R 178, 286, 704	ERJ2GEJ471X	RESISTOR, 1/16W, 470Ω	3
R 181	D1HA1048A001	RESISTOR ARRAY	1
R 182	D1H81504A024	RESISTOR ARRAY	1
R 205, 206, 211	D1H84724A024	RESISTOR ARRAY	3
R 207	D1H81044A024	RESISTOR, 1/16W, 100KΩ	1
R 208, 209	ERJ2RKF4530X	RESISTOR, 1/16W, 453Ω	2
R 221, 364	ERJ2GEJ334X	RESISTOR, 1/16W, 330KΩ	2
R 227, 311, 391, 392, 423, 470, 472, 493, 494, 495, 602, 603, 668, 669, 670, 673, 674, 675, 676, 683, 694, 802, 803	ERJ2GEJ101X	RESISTOR, 1/16W, 100Ω	23
R 228, 229	ERJ2RKF3323X	RESISTOR, 1/16W, 332KΩ	2
R 230	ERJ2GEJ106X	RESISTOR, 1/16W, 10MΩ	1
R 244, 245, 246, 253, 293, 475, 476, 477, 478, 479, 482, 483, 500, 501, 502, 503	D1HA1038A001	RESISTOR ARRAY	16
R 250, 395, 618, 662, 671	ERJ2GEJ105X	RESISTOR, 1/16W, 1MΩ	5
R 251	ERJ2GEJ121X	RESISTOR, 1/16W, 120Ω	1
R 252, 401, 402, 403, 832	ERJ2GEJ472X	RESISTOR, 1/16W, 4.7KΩ	5
R 263, 265, 266, 267, 268, 269, 272, 273, 300, 301, 304, 305, 314, 320, 329, 363, 393, 394, 430, 431, 432, 433, 617, 619, 620, 621, 661, 665, 667, 672	ERJ2GEJ104X	RESISTOR, 1/16W, 100KΩ	30
R 279, 292	D1H81024A024	RESISTOR ARRAY	2
R 281, 282, 283, 284, 285, 287, 288, 294, 295, 296, 780	ERJ2GEJ221X	RESISTOR, 1/16W, 220Ω	11
R 332	ERJ2GEJ331X	RESISTOR, 1/16W, 330Ω	1
R 334	ERJ2GEJ512X	RESISTOR, 1/16W, 5.1KΩ	1
R 380, 381, 382, 383, 384, 385, 386, 387	ERJ2RKF49R9X	RESISTOR, 1/16W, 49.9Ω	8
R 400	ERJ2RHD303X	RESISTOR, 1/16W, 30KΩ	1
R 404	ERJ2RKF4871X	RESISTOR, 1/16W, 4.87KΩ	1
R 405, 406, 605, 608	ERJ2RHD103X	RESISTOR, 1/16W, 10KΩ	4
R 420, 421, 422, 677, 742, 770, 793, 794, 795, 796	ERJ2GEJ223X	RESISTOR, 1/16W, 22KΩ	10
R 490, 496, 506	ERJ2RKF3901X	RESISTOR, 1/16W, 3.9KΩ	3
R 491	ERJ2RKF5602X	RESISTOR, 1/16W, 56KΩ	1
R 601	D1ZZ00000046	RESISTOR, 1W, 5mΩ	1
R 606, 611, 706	ERJ2RKF1003X	RESISTOR, 1/16W, 100KΩ	3
R 607, 610, 809	ERJ2RKF1503X	RESISTOR, 1/16W, 150KΩ	3
R 614	ERJ3GEYJ3R3V	RESISTOR, 1/16W, 3.3Ω	1
R 616, 636, 681	ERJ2GEJ473X	RESISTOR, 1/16W, 47KΩ	3
R 622, 623	D1BDR1000002	RESISTOR, 1/8W, 0.1Ω	2
R 624	D1BDR068A100	RESISTOR, 0.068Ω	1
R 626	ERJ3GEYJ562V	RESISTOR, 1/16W, 5.6KΩ	1
R 630	ERJ2RKF1102X	RESISTOR, 1/16W, 11KΩ	1
R 631	ERJ2RKF1302X	RESISTOR, 1/16W, 13KΩ	1
R 634, 654, 761, 778	D1BDR022A099	RESISTOR, 1/3W, 0.022Ω	4
R 635, 731, 839	D1BDR018A099	RESISTOR, 1/3W, 0.018Ω	3
R 637, 663, 747, 752, 776, 822	ERJ2GEJ474X	RESISTOR, 1/16W, 470KΩ	6
R 640, 736, 764	ERJ2GEJ153X	RESISTOR, 1/16W, 15KΩ	3
R 642, 738, 766, 799, 800	ERJ3GEYJ100V	RESISTOR, 1/16W, 10Ω	5
R 643	ERA3YEB622V	RESISTOR, 1/16W, 6.2KΩ	1
R 644, 829, 830	ERA3YKB104V	RESISTOR, 1/16W, 100KΩ	3
R 645, 768, 842	ERA3YEB203V	RESISTOR, 1/16W, 20KΩ	3
R 647	ERJ2GEJ333X	RESISTOR, 1/16W, 33KΩ	1
R 648	ERJ3RBD303V	RESISTOR, 1/16W, 30KΩ	1
R 649	ERJ3RBD103V	RESISTOR, 1/16W, 10KΩ	1
R 650	ERJ3RBD132V	RESISTOR, 1/16W, 1.3KΩ	1

R 653, 749, 760, 777, 779, 833	D1BDR033A099	RESISTOR, 1/3W, 0.033Ω	6
R 664	ERJ2GEJ684X	RESISTOR, 1/16W, 680KΩ	1
R 666	ERJ2GEJ225X	RESISTOR, 1/16W, 2.2MΩ	1
R 678, 682	ERJ6GEYJ122V	RESISTOR, 1/10W, 1.2KΩ	2
R 679, 680	ERJ6GEYJ222V	RESISTOR, 1/10W, 2.2KΩ	2
R 690	ERJ2GEJ393X	RESISTOR, 1/16W, 39KΩ	1
R 696	ERJ2RKF1800X	RESISTOR, 1/16W, 180Ω	1
R 699	ERJ2RKF4702X	RESISTOR, 1/16W, 47KΩ	1
R 700, 801	ERJ2RKF6801X	RESISTOR, 1/16W, 6.80KΩ	2
R 701	ERJ2RKF5103X	RESISTOR, 1/16W, 510KΩ	1
R 702, 708, 714	ERJ3GEYJ1R0V	RESISTOR, 1/16W, 1Ω	3
R 709	ERJ2RHD222X	RESISTOR, 1/16W, 2.2KΩ	1
R 710	ERJ2RKF5101X	RESISTOR, 1/16W, 5.1KΩ	1
R 712	ERJ2RKF3601X	RESISTOR, 1/16W, 3.6KΩ	1
R 716, 810	ERJ3GEYJ101V	RESISTOR, 1/16W, 100Ω	2
R 718, 790	ERJ3GEYJ2R2V	RESISTOR, 1/16W, 2.2Ω	2
R 719, 808	D1ZZ00000093	RESISTOR, 1W, 1mΩ	2
R 739	ERJ2RKF4701X	RESISTOR, 1/16W, 4.7KΩ	1
R 740, 744, 772	ERJ2RKF1502X	RESISTOR, 1/16W, 15KΩ	3
R 743	ERJ2RKF7501X	RESISTOR, 1/16W, 7.5KΩ	1
R 748	ERJ2RKF1101X	RESISTOR, 1/16W, 1.1KΩ	1
R 751	D1BDR016A099	RESISTOR, 1/3W, 0.016Ω	1
R 767	ERA3YEB621V	RESISTOR, 1/16W, 620Ω	1
R 769, 835	ERA3YEB243V	RESISTOR, 1/16W, 24KΩ	2
R 773	ERJ2RKF1202X	RESISTOR, 1/16W, 12KΩ	1
R 792, 813	ERJ2RKF6981X	RESISTOR, 1/16W, 6.98KΩ	2
R 806	ERJ2RKF4022X	RESISTOR, 1/16W, 40.2KΩ	1
R 807	D1H8R0040009	JUMPER	1
R 811	ERJ2RKF1691X	RESISTOR, 1/16W, 1.69KΩ	1
R 812	ERJ2GEJ303X	RESISTOR, 1/16W, 30KΩ	1
R 815	ERJ3GEYJ104V	RESISTOR, 1/16W, 100KΩ	1
R 817	ERJ2RKF1433X	RESISTOR, 1/16W, 143KΩ	1
R 821	ERJ2RKD114X	RESISTOR, 1/16W, 110KΩ	1
R 823	ERJ2RHD3652X	RESISTOR, 1/16W, 36.5KΩ	1
R 825	ERJ2GEJ154X	RESISTOR, 1/16W, 150KΩ	1
R 826, 827	ERJ2RHD302X	RESISTOR, 1/16W, 3KΩ	2
R 831, 836, 843	ERA3YEB333V	RESISTOR, 1/16W, 33KΩ	3
SW 2	K0D112B00071	SW	1
X 1	H0J143500058	OSCILLATOR, 14.318MHz	1
X 2	H0J327200115	OSCILLATOR, 32.768KHz	1
X 3	H0J245500083	XTAL	1
X 4	H0J250500076	XTAL	1
X 5	H2D800400015	OSCILLATOR, 8MHz	1
ZA 1, 2, 5, 6, 7, 10, 11	K1YGZZ000060	SPACER	7
AUDIO PCB			
C 900, 906, 916, 917, 934, 935	F1G1A104A014	CAPACITOR, 10V, 0.1μF	6
C 901, 903, 943, 948	F1H1A225A039	CAPACITOR, 10V, 2.2μF	4
C 902, 907, 908, 912, 915, 918, 919, 932, 944	F1G0J224A001	CAPACITOR, 6.3V, 0.22μF	9
C 909	F1G1E103A062	CAPACITOR, 25V, 0.01μF	1
C 910, 928, 929, 930, 931	F1H1A1050015	CAPACITOR, 10V, 1μF	5
C 911, 922, 937, 938, 951	F1J0J106A016	CAPACITOR, 6.3V, 10μF	5
C 913	F1G1H221A495	CAPACITOR, 50V, 220pF	1
C 914, 920, 921, 952	F1G1C104A042	CAPACITOR, 16V, 0.1μF	4
C 923, 924	F1H0J1050022	CAPACITOR, 6.3V, 1μF	2
C 925, 939, 940	F1G1H102A496	CAPACITOR, 50V, 1000pF	3
C 926, 927	F1H1A474A028	CAPACITOR, 10V, 0.47μF	2
C 933, 941, 946	F1G1H1010005	CAPACITOR, 50V, 100pF	3
C 936	F1G0J105A001	CAPACITOR, 6.3V, 1μF	1
C 942, 945	F1G1H471A496	CAPACITOR, 50V, 470pF	2
C 949, 950, 953, 954	F1L0J107A016	CAPACITOR, 6.3V, 100μF	4
CN 901	K1MN40B00048	CONNECTOR	1

CN 902		K1MY12BA0309	CONNECTOR	1
CN 904		K1KA02BA0014	CONNECTOR	1
D 902		BOJDBE000002	DIODE	1
F 902	△	K5H202Z00005	FUSE, 2A, 32V	1
IC 900		C1CB00002733	AUDIO CODEC	1
IC 901		COCBBCBC00130	IC, REGULATORY	1
IC 902		COJBAE000306	IC,	1
IC 903		COJBAS000251	IC	1
IC 904		COABBA000093	IC, OP AMP	1
IC 905		AN12945A-VB	IC, AUDIO AMP	1
JK 901, 902		K2HC103B0197	JACK	2
JK 903		K1QZA1AE0001	CONNECTOR	1
L 900, 901, 904, 905, 907		J0JCC0000286	INDUCTOR	5
L 902, 903		J0MAB0000174	INDUCTOR	2
L 906		J0JJC0000015	INDUCTOR	1
Q 900, 905, 908		B1GBCFNN0042	TRANSISTOR	3
Q 902		XP0421300L	TRANSISTOR	1
Q 903, 904		B1CFGD000023	TRANSISTOR	2
Q 907		B1GDGFNN0031	TRANSISTOR	1
R 900, 904, 907, 909, 913, 920, 921, 928, 932, 940, 942, 947, 951		ERJ2GEJ103X	RESISTOR, 1/16W, 10KΩ	13
R 901, 922		ERJ2RKF2671X	RESISTOR, 1/16W, 2.67KΩ	2
R 902		ERJ2GEJ330X	RESISTOR, 1/16W, 33Ω	1
R 905, 910, 936		ERJ2GEJ472X	RESISTOR, 1/16W, 4.7KΩ	3
R 906, 911		ERJ2GEJ390X	RESISTOR, 1/16W, 39Ω	2
R 912		ERJ2GEJ473X	RESISTOR, 1/16W, 47KΩ	1
R 915, 916		ERJ2RKF1003X	RESISTOR, 1/16W, 100KΩ	2
R 917		ERJ2GE0R00X	RESISTOR, 1/16W, 0Ω	1
R 918, 919, 930, 937, 939, 943, 944		ERJ2GEJ104X	RESISTOR, 1/16W, 100KΩ	7
R 923		ERJ2GEJ100X	RESISTOR, 1/16W, 10Ω	1
R 926		ERJ2RHD3922X	RESISTOR, 1/16W, 39.2KΩ	1
R 927		ERJ2RHD203X	RESISTOR, 1/16W, 20KΩ	1
R 929		ERJ2RKF1602X	RESISTOR, 1/16W, 16KΩ	1
R 931, 933		ERJ2RKF1002X	RESISTOR, 1/16W, 10KΩ	2
R 934, 938, 946, 948		ERJ2GEJ102X	RESISTOR, 1/16W, 1KΩ	4
R 935		ERJ2GEJ471X	RESISTOR, 1/16W, 470Ω	1
R 941, 945		ERJ2GEJ222X	RESISTOR, 1/16W, 2.2KΩ	2
R 950		ERJ3GEY0R00V	RESISTOR, 1/16W, 0Ω	1
IO PCB				
C 880		F1H1H104A748	CAPACITOR, 50V, 0.1μF	1
C 883		F1L1E106A017	CAPACITOR, 25V, 10μF	1
C 884, 885, 886, 887, 888, 889, 890		F1G1H330A542	CAPACITOR, 50V, 33pF	7
C 891		F1G1C104A042	CAPACITOR, 16V, 0.1μF	1
C 892, 893		EZASCE101M	CAPACITOR ARRAY	2
CN 880		K1MY24AA0158	CONNECTOR	1
CN 881		K1FA209BA004	CONNECTOR	1
CN 882		K1FB115BA014	CONNECTOR	1
CN 883	△	DFJS1063ZA	I/O DC CABLE	1
D 880		BOJCPD000023	DIODE	1
D 881		MA2J72900L	DIODE	1
F 800	△	K5H802300002	FUSE, 8A, 72V	1
JK 880	△	K2EYB000001	JACK	1
L 880		J0JKC0000007	INDUCTOR	1
L 881, 882, 883, 884, 885, 886, 887		J0JDC0000038	CHIP BEADS	7
PA 880	△	D4FB1R100015	PROTECTOR 1.1A	1
R 881		D1BDR4700001	RESISTOR, 1/8W, 0.47Ω	1
R 882, 883, 884		ERJ2RKF75R0X	RESISTOR, 1/16W, 75Ω	3
R 885, 886		ERJ2GEJ222X	RESISTOR, 1/16W, 2.2KΩ	2
PAD PCB				
C 800, 801		F1G1H681A496	CAPACITOR, 50V, 680pF	2

C 802		F1G1E103A062	CAPACITOR, 25V, 0.01µF	1
C 803, 804, 806		F1G1C104A042	CAPACITOR, 16V, 0.1µF	3
C 805		F1J0J106A016	CAPACITOR, 6.3V, 10µF	1
CN 800		K1MY04BA0104	CONNECTOR	1
CN 801		K1MY06BA0309	CONNECTOR	1
CN 802		K1MY40A00001	CONNECTOR	1
CN 803		K1MY08AA0158	CONNECTOR	1
CN 804, 807		K1KA02BA0014	CONNECTOR	2
CN 805		K1MY10AA0158	CONNECTOR	1
CN 806		K1MY10BA0309	CONNECTOR	1
F 800	△	K5H202Z00005	FUSE, 2A, 32V	1
IC 800		C0EBE0000460	IC	1
IC 801		C1DB00001417	IC, FLAT PAD CONTROLLER	1
Q 800, 801		B1GKCFJN0004	TRANSISTOR	2
R 800		ERJ2GEJ273X	RESISTOR, 1/16W, 27KΩ	1
R 801, 802		ERJ2GEJ822X	RESISTOR, 1/16W, 8.2KΩ	2
R 803		ERJ2GEJ105X	RESISTOR, 1/16W, 1MΩ	1
R 804, 805		ERJ2GEJ222X	RESISTOR, 1/16W, 2.2KΩ	2
RA 800		D1H81034A024	RESISTOR ARRAY	1
SW 800, 801		K0ZZ00000618	SW	2
SW 802, 803		EVQPLDA15	SWITCH	2
X 800		H2D400400012	OSCILLATOR, 4MHz	1
SW PCB				
CN 950		K1MY10AA0158	CONNECTOR	1
LD 951		B3ABB0000210	DIODE	1
SW 950, 951, 952, 953, 954, 955		EVQPLDA15	SWITCH	6
LED-LEFT PCB				
CN 841		K1MY10AA0158	CONNECTOR	1
LD 841, 842, 843, 844, 845, 846		B3ABB0000210	DIODE	6
PR PCB				
C 851, 852, 854		F1J1A1050021	CAPACITOR, 10V, 1µF	3
C 855, 856, 857		J0MAB0000146	INDUCTOR	3
CA 851, 852, 854, 857, 858, 859		J0HABC000004	CAPACITOR ARRAY	6
CN 850		K1KYA0A00018	CONNECTOR	1
CN 851		K1KAA0AA0244	CONNECTOR	1
L 850		J0MAB0000200	INDUCTOR	1
L 852, 853		J0JJC0000015	INDUCTOR	2
LED-RIGHT PCB				
LD 781		B3AGB0000040	DIODE	1
LD 782		B3ADB0000065	DIODE	1
LD 783		B3ABB0000210	DIODE	1
CN 780		K1MY06AA0158	CONNECTOR	1
SD PCB				
LD 880		B3ACB0000020	DIODE	1
C 880		F1G1H330A542	CAPACITOR, 50V, 33pF	1
C 881, 882, 884, 885, 886, 887		F1G1C104A042	CAPACITOR, 16V, 0.1µF	6
C 889, 890, 891, 892		F1H2A103A020	CAPACITOR, 100V, 0.01µF	4
C 893		F1L3D102A003	CAPACITOR, 2000V, 1000pF	1
CN 880		K1MY24BA0310	CONNECTOR	1
CN 881		K1NA09E00076	CONNECTOR	1
CN 882		K1KA08BA0014	CONNECTOR	1
R 880		D1H87504A024	RESISTOR ARRAY	1
R 882		ERJ2GEJ103X	RESISTOR, 1/16W, 10KΩ	1
T 880, 881		G5BYC0000015	TRANCE	2
HSDPA PCB				
C 600, 603		F1G1H1010005	CAPACITOR, 50V, 100pF	2
C 601, 602, 604, 608		F1J0J106A016	CAPACITOR, 6.3V, 10µF	4
C 609, 610		EEFUD0J151ER	CAPACITOR, 6.3V, 150µF	2
C 613, 614, 615, 616		F1G1C104A042	CAPACITOR, 16V, 0.1µF	4
C 611, 612, 617, 620		F1G1C104A042	CAPACITOR, 16V, 0.1µF	4

C 619		EEFCX0J121R	CAPACITOR	1
C 622		F1G1H221A495	CAPACITOR, 50V, 220pF	1
CN 600		K1MN50BA0153	CONNECTOR	1
CN 601		K1MY52BA0190	CONNECTOR	1
CN 602		K1NA08E00013	SIM CONNECTOR	1
CN 604		K1MY10BA0309	CONNECTOR	1
D 600		BOKB00000044	DIODE	1
D 603		BOJCRC000002	DIODE	1
IC 600		C0JBAZ002422	IC, FET SWITCH	1
IC 601		C0JBAC000382	IC, LOGIC	1
IC 602		C0DBAYY00204	IC, DC/DC CONVERTER	1
IC 603		C0DBZGD00016	IC	1
IC 604		C0DBZYY00026	IC, USB POWER SW	1
IC 605		C0EBE0000460	IC	1
JK 600, 601		K1QZA1AE0001	CONNECTOR	2
L 600		J0JJC0000015	INDUCTOR	1
L 601		J0JJC0000015	INDUCTOR	1
L 602		J0MAB0000200	INDUCTOR	1
L 603		G1C2R7MA0273	INDUCTOR, COIL	1
Q 600		B1DHFD000015	TRANSISTOR	1
Q 602, 604		B1GBCFNN0042	TRANSISTOR	2
Q 603		B1CFGD000023	TRANSISTOR	1
R 600		D1BDR0330001	RESISTOR, 1/8W, 0.033Ω	1
R 601		D1BDR0470002	RESISTOR, 1/8W, 0.047Ω	1
R 602, 606, 609, 615, 616		ERJ2GEJ103X	RESISTOR, 1/16W, 10KΩ	5
R 603, 613		ERJ2GE0R00X	RESISTOR, 1/16W, 0Ω	2
R 604, 611, 612, 619		ERJ2GEJ101X	RESISTOR, 1/16W, 100Ω	4
R 608		ERJ2RKF1001X	RESISTOR, 1/16W, 1KΩ	1
R 610		ERJ6GEY0R00V	RESISTOR, 1/10W, 0Ω	1
R 617		ERJ2RKF1002X	RESISTOR, 1/16W, 10KΩ	1
R 618		ERA3YEB303V	RESISTOR, 1/16W, 30KΩ	1
R 621, 622		ERJ2GEJ104X	RESISTOR, 1/16W, 100KΩ	2
SW 600		K0D444A00041	SWTICH	1
ZA 600, 601		K1YZZ000060	SPACER	2
CN 603		K1FY104BA024	CONNECTOR, USB	1
PPower SWPCB				
CN 980		K1KA02AA0262	CONNECTOR	1
SW 980		K0D112A00096	SW	1
BT PCB				
C 1		F1J0J106A016	CAPACITOR, 6.3V, 10μF	1
C 2, 4, 7, 11		F1G1C104A042	CAPACITOR, 16V, 0.1μF	4
C 3, 5		F1G1H102A496	CAPACITOR, 50V, 1000pF	2
C 6, 9		F1G1E103A062	CAPACITOR, 25V, 0.01μF	2
C 8		F1G1H270A542	CAPACITOR, 50V, 27pF	1
C 10		F1G1HR50A543	CAPACITOR, 50V, 0.5pF	1
CN 2		K1MY10BA0309	CONNECTOR	1
IC 1		C0JBAZ002422	IC, FET SWITCH	1
IC 2		N5HZZ0000056	BLUETOOTH MODULE	1
IC 3		C0EBE0000460	IC	1
IC 5		C0JBAC000382	IC, LOGIC	1
JK 1		K1QZA1AE0001	CONNECTOR	1
L 1, 2		J0JJC0000015	INDUCTOR	2
L 4		G1C5N6ZA0029	INDUCTOR	1
L 5		J0MAB0000200	INDUCTOR	1
Q 1		B1GBCFNN0042	TRANSISTOR	1
Q 2		B1DHDC000028	TRANSISTOR	1
R 1, 2, 3		ERJ2GEJ103X	RESISTOR, 1/16W, 10KΩ	3
TS PCB				
C 900, 901, 902, 903		F1G1E472A062	CAPACITOR, 25V, 4700pF	4
C 904, 905, 906, 907		F1G1H681A496	CAPACITOR, 50V, 680pF	4
C 908, 911, 912		F1G1C104A042	CAPACITOR, 16V, 0.1μF	3
C 909		F1G1E223A062	CAPACITOR, 25V, 0.022μF	1
C 910		F1G1H102A496	CAPACITOR, 50V, 1000pF	1

C 913, 916	F1J0J106A016	CAPACITOR, 6.3V, 10 μ F	2
C 914	F1G0J224A001	CAPACITOR, 6.3V, 0.22 μ F	1
CN 900	K1MN04B00073	CONNECTOR	1
CN 901	K1KA06BA0014	CONNECTOR	1
IC 900	C0EBE0000460	IC	1
IC 902	C1CB00002515	IC, TOUCHPANEL CONTROLLER	1
Q 900, 901	XP0431400L	TRANSISTOR	2
Q 902	B1GDCFNN0031	TRANSISTOR	1
R 900, 903, 905, 909, 911, 912, 917, 918, 922, 923	ERJ2GEJ102X	RESISTOR, 1/16W, 1K Ω	10
R 906, 930	ERJ2GEJ473X	RESISTOR, 1/16W, 47K Ω	2
R 908	ERJ2GEJ273X	RESISTOR, 1/16W, 27K Ω	1
R 913, 914, 915, 916	ERJ2GEJ822X	RESISTOR, 1/16W, 8.2K Ω	4
R 919, 925	ERJ2GE0R00X	RESISTOR, 1/16W, 0 Ω	2
R 926	D1HA47380002	RESISTOR ARRAY	1
R 927, 928	ERJ2GEJ270X	RESISTOR, 1/16W, 27 Ω	2
R 929	ERJ2GEJ152X	RESISTOR, 1/16W, 1.5K Ω	1
X 900	H2D600400005	OSCILLATOR, 6MHz	1