

# 800-900 MHz +30 dBm Power GaAs FET

## Features

- ❑ High Gain
- ❑ +30 dBm Power Output
- ❑ Proprietary Power FET Process
- ❑ >40% Linear Power Added Efficiency
- ❑ Surface Mount SO-8 Power Package

## Applications

- ❑ ISM Band Base Stations and Terminals
- ❑ Cellular Base Stations and Terminals
- ❑ Wireless Local Loop

## Description

The CFK2062-P1 is a high-gain FET intended for driver amplifier applications in high-power systems, and output stage usage in medium power applications at power levels up to +30 dBm. The device is easily matched and provides excellent

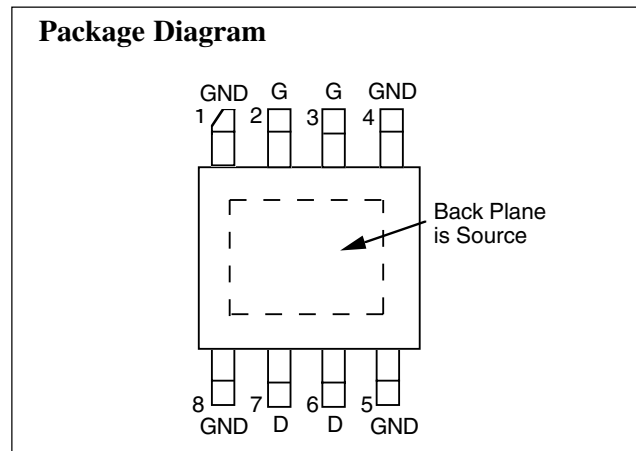

linearity at 1 Watt. Manufactured in Celeritek's proprietary power FET process, this device is assembled in an industry standard surface mount SO-8 power package that is compatible with high volume, automated board assembly techniques.

## Specifications (TA = 25°C) The following specifications are guaranteed at room temperature in Celeritek test fixture at 850 MHz.

Parameters	Conditions	Min	Typ	Max	Units
<b>V<sub>d</sub> = 8V, I<sub>d</sub> = 400 mA (Quiescent)</b>					
P-1 dB		29.0	30.0	—	dBm
SSG		18.0	20.0	—	dB
3rd Order Products (1)		—	30	—	dBc
Efficiency	@ P1dB	—	40	—	%
<b>V<sub>d</sub> = 5V, I<sub>d</sub> = 600 mA (Quiescent)</b>					
P-1 dB		—	29.5	—	dBm
SSG		—	19.0	—	dB

Parameters	Conditions	Min	Typ	Max	Units
g <sub>m</sub>	V <sub>ds</sub> = 2.0V, V <sub>gs</sub> = 0V	—	650	—	mS
I <sub>dss</sub>	V <sub>ds</sub> = 2.0V, V <sub>gs</sub> = 0V	—	1.4	—	A
V <sub>p</sub>	V <sub>ds</sub> = 3.0V, I <sub>ds</sub> = 25 mA	—	-1.8	—	Volts
BV <sub>GD</sub>	I <sub>gd</sub> = 2.5 mA	15	17	—	Volts
θ <sub>JL</sub> (2)	@ 150°C TCH	—	12	—	°C/W

## Absolute Maximum Ratings

Parameter	Symbol	Rating
Drain-Source Voltage	V <sub>DS</sub>	10V (3)
Gate-Source Voltage	V <sub>GS</sub>	-5V
Drain Current	I <sub>DS</sub>	I <sub>dss</sub>
Continuous Dissipation	P <sub>T</sub>	6W
Channel Temperature	T <sub>CH</sub>	175°C
Storage Temperature	T <sub>STG</sub>	-65°C to +175°C

## SO-8 Power Package Physical Dimensions

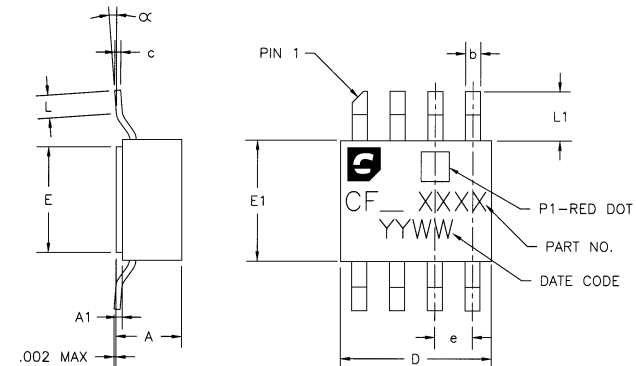

DIMENSION	MINIMUM	NOMINAL	MAXIMUM
A		.086[2.184]	.100[2.540]
A1	.005[.1270]	.008[.2032]	.011[.2794]
b	.017[.4318]	.020[.5080]	.023[.5842]
c	.007[.1778]	.008[.2032]	.009[.2286]
D	.195[4.953]	.200[5.080]	.205[5.207]
E	.135[3.429]	.140[3.556]	.145[3.683]
E1	.155[3.937]	.160[4.064]	.165[4.191]
e		.050[1.270]	
L	.020[.5080]		.040[1.016]
L1	.055[1.397]	.065[1.651]	.075[1.905]
α	0°		8°

DIMENSIONS IN INCHES [MILLIMETERS]

## Notes:

1. Sum to two tones with 1 MHz spacing = 25 dBm.
2. See thermal considerations information on page 4.
3. Maximum potential difference across the device (V<sub>d</sub> + V<sub>g</sub>) cannot exceed 12V.

# 800-900 MHz +30 dBm Power GaAs FET

## Typical Scattering Parameters (TA = 25°C, Vds = 5 V, Ids = 600 mA)

Frequency (GHz)	S <sub>11</sub>		S <sub>21</sub>		S <sub>12</sub>		S <sub>22</sub>	
	Mag	Ang	Mag	Ang	Mag	Ang	Mag	Ang
0.6	0.927	-129.75	8.7	102.7	0.024	21.95	0.576	-178.45
0.7	0.921	-138.64	7.587	97.2	0.025	16.98	0.588	179.24
0.8	0.919	-145.3	6.726	92.32	0.025	12.77	0.597	177.37
0.9	0.919	-150.58	6.02	88.2	0.025	12.07	0.6	176.07
1.0	0.914	-154.69	5.449	84.82	0.025	8.72	0.6	175.04
1.1	0.911	-157.8	5.018	82.03	0.026	7.57	0.597	174.42
1.2	0.91	-160.09	4.678	79.43	0.027	6.24	0.594	173.69
1.3	0.908	-162.37	4.423	76.85	0.027	4.79	0.588	172.66
1.4	0.904	-164.19	4.225	74.15	0.028	2.63	0.578	171.66
1.5	0.9	-166.3	4.066	71.35	0.029	2.62	0.567	170.4
2.0	0.883	177.09	3.605	52.62	0.05	-10.6	0.512	154.61
2.5	0.887	150.54	2.944	28.96	0.035	-30.13	0.539	128.94
3.0	0.917	135.01	2.081	13.19	0.03	-41.27	0.623	118.42
3.5	0.932	137.14	1.635	8.18	0.028	-41.69	0.643	124.18
4.0	0.913	143.42	1.641	3.36	0.032	-41.15	0.557	131.38

## (TA = 25°C, Vds = 8 V, Ids = 400 mA)

0.6	0.91	-131.25	9.129	100.5	0.026	17.07	0.521	-174.04
0.7	0.905	-139.87	7.943	95.18	0.026	13.22	0.534	-176.65
0.8	0.906	-146.47	7.028	90.26	0.026	11.05	0.543	-178.82
0.9	0.906	-151.44	6.281	86.16	0.027	8.59	0.547	179.94
1.0	0.904	-155.33	5.68	82.61	0.027	6.34	0.548	178.8
1.1	0.903	-158.37	5.226	79.83	0.027	3.72	0.547	178.18
1.2	0.903	-160.69	4.866	77.15	0.027	3.34	0.544	177.57
1.3	0.899	-167.2	4.574	74.6	0.028	0.5	0.538	176.86
1.4	0.897	-164.68	4.366	71.76	0.029	1.6	0.53	176.13
1.5	0.892	-166.63	4.203	68.96	0.03	-0.36	0.519	174.97
2.0	0.877	176.74	3.696	50.36	0.035	-13.77	0.463	160.21
2.5	0.882	150.43	3.014	26.66	0.036	-31.65	0.486	133.49
3.0	0.915	135.06	2.136	10.26	0.031	-46.6	0.579	121.99
3.5	0.93	137.37	1.662	4.59	0.027	-43.86	0.611	128.44
4.0	0.912	143.75	1.642	-0.35	0.031	-43.95	0.541	137.64

**RF Match** Data shown in the performance graphs was taken in the test circuit shown at right. Layout is important for proper operation. Phase length of input and output 50Ω line varies as a function of exact desired frequency of operation. Output shunt inductor effects output performance. Celeritek recommends the use of a high impedance printed inductor Lambda/4 in length. Please contact the factory for an evaluation board and/or more detailed application support.

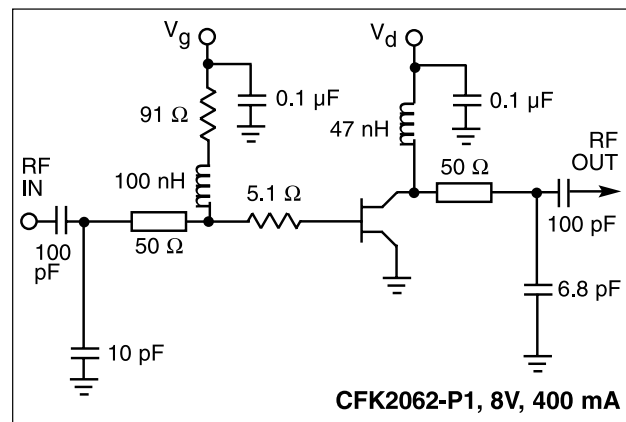

# 800-900 MHz +30 dBm Power GaAs FET



August 2006 - Rev 03-Aug-06

**CFK2062-PI**

## Typical Performance

**Power Output & Power Added Efficiency vs Power Input**  
850 MHz,  $V_{DS} = 8\text{ V}$ ,  $I_{DS} = 400\text{ mA}$

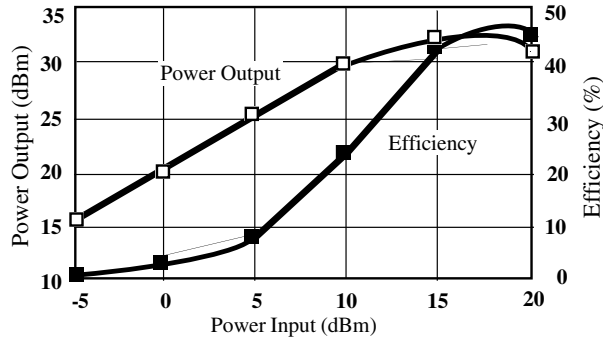

**Power Output & Power Added Efficiency vs Power Input**  
850 MHz,  $V_{DS} = 5\text{ V}$ ,  $I_{DS} = 600\text{ mA}$

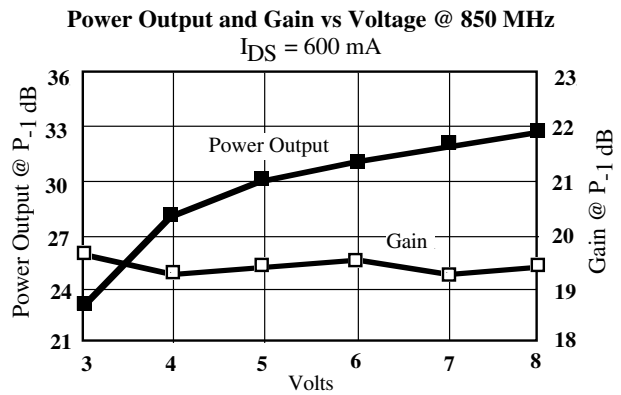
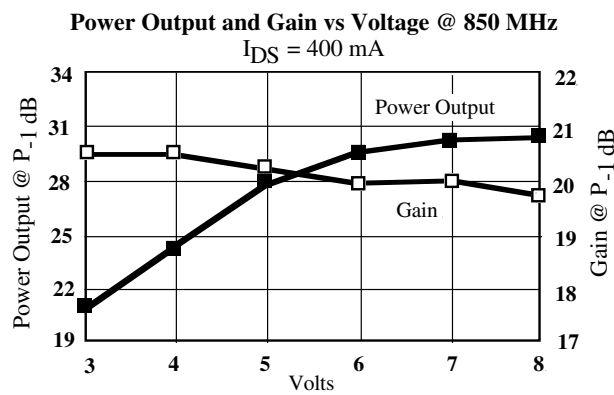
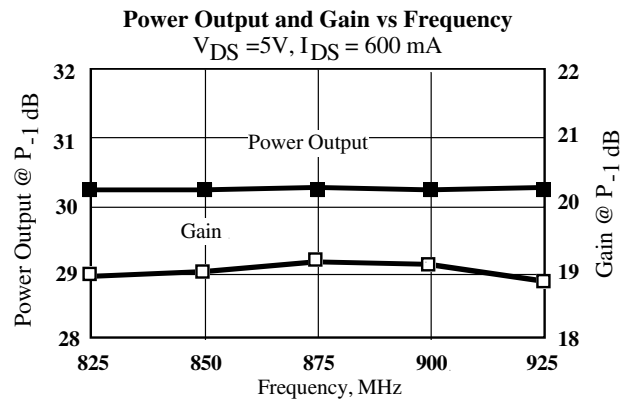
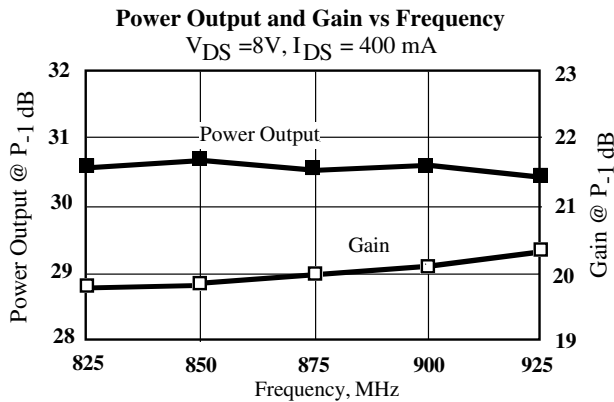
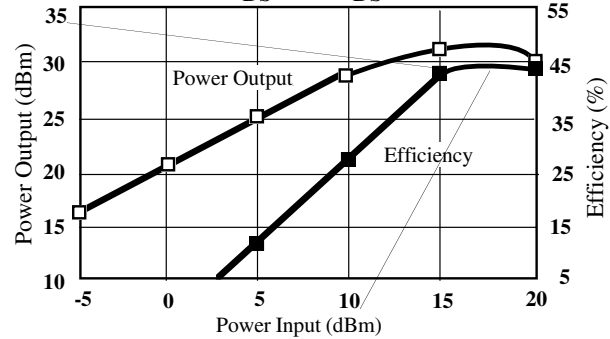

# 800-900 MHz +30 dBm Power GaAs FET

## Thermal Considerations

The data shown was taken on a 31 mil thick FR-4 board with 1 ounce copper on both sides. The board was mounted to a baseplate with 3 screws as shown. The screws bring the top side copper temperature to the same value as the baseplate. The thermal resistance to the indicated reference lead,  $\Theta_{JL}$ , is 12°C/W. The thermal resistance to the reference screw is 14°C/W.

1. Use 1 or 2 ounce copper if possible.
2. Solder all eight leads of the CFK2062-P1 package to the appropriate electrical connection.
3. Solder the copper pad on the backside of the CFK2062-P1 package to the ground plane.
4. Use a large ground pad area with many plated through-holes as shown.
5. If possible, use at least one screw no more than 0.2 inches from the CFK2062-P1 package to provide a low thermal resistance path to the baseplate of the package.

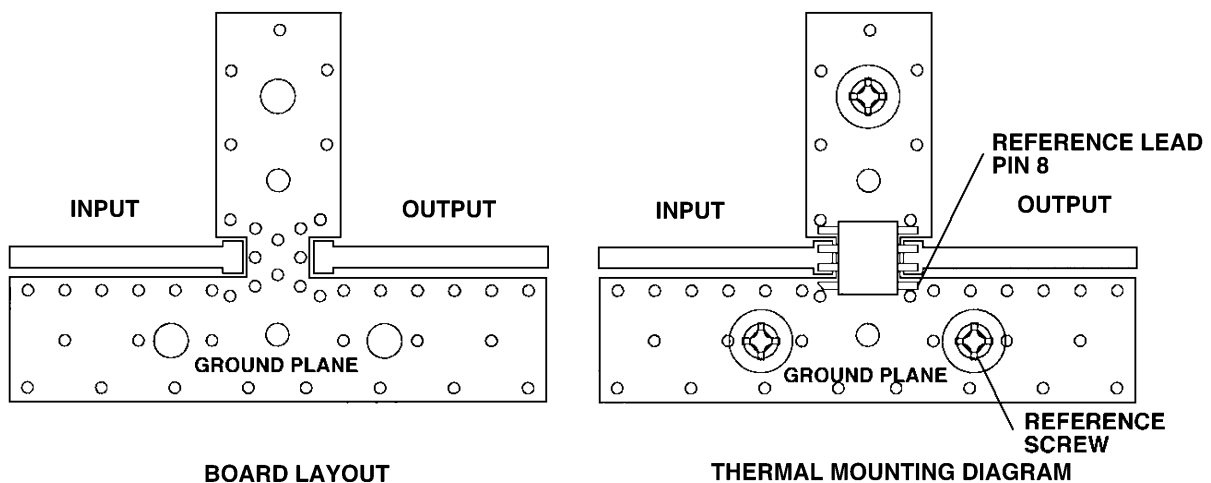

## Ordering Information

The CFK2062-P1 power stage is available in a SO-8 surface mount package. Devices are available in tape and reel. Ordering part numbers are listed.

<u>Part Number for Ordering</u>	<u>Function</u>	<u>Package</u>
CFK2062-P1	800 - 900 MHz Power Stage	SO-8 surface mount power package
CFK2062-P1-000T	800 - 900 MHz Power Stage	SO-8 surface mount power package in tape and reel