



Product Specifications  
July 1997 (1 of 4)

## 2.3 to 2.5 GHz +34 dBm Power GaAs FET

### Features

- ❑ High Gain
- ❑ +34 dBm Power Output
- ❑ Proprietary Power FET Process
- ❑ >45% Linear Power Added Efficiency
- ❑ +29 dBm with 30 dBc Third Order Products
- ❑ Surface Mount SO-8 Power Package

### Applications

- ❑ ISM Band Base Stations and Terminals
- ❑ PCS/PCN Base Stations and Terminals
- ❑ Wireless Local Loop

### Description

The CFK2162-P5 is a high-gain FET intended for driver amplifier applications in high-power systems, and output stage usage in medium power applications at power levels up to +34 dBm. The device is easily matched and provides excellent

### Package Diagram

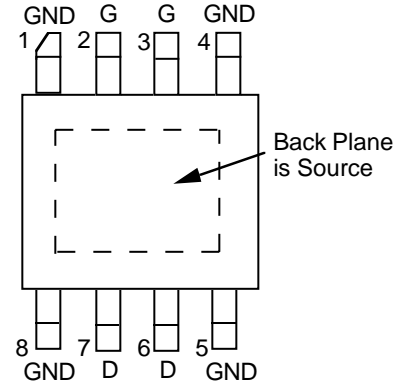

linearity at 2 Watts. Manufactured in Celeritek's proprietary power FET process, this device is assembled in an industry standard surface mount SO-8 power package that is compatible with high volume, automated board assembly techniques.

**Specifications** (TA = 25°C) The following specifications are guaranteed at room temperature in Celeritek test fixture at 2.5 GHz.

Parameters	Conditions	Min	Typ	Max	Units
<b>V<sub>d</sub> = 8V, I<sub>d</sub> = 800 mA (Quiescent)</b>					
P-1dB		33.0	34.0	—	dBm
SSG		11.0	12.0	—	dB
3rd Order Products (1)		26	30	—	dBc
Efficiency	@ P1dB	—	40	—	%
<b>V<sub>d</sub> = 5V, I<sub>d</sub> = 350 mA (Quiescent)</b>					
P-1dB		—	30.0	—	dBm
SSG		—	9.0	—	dB
<b>V<sub>d</sub> = 5V, I<sub>d</sub> = 1200 mA (Quiescent)</b>					
P-1dB		—	32.5	—	dBm
SSG		—	10.0	—	dB

Parameters	Conditions	Min	Typ	Max	Units
g <sub>m</sub>	V <sub>ds</sub> = 2.0V, V <sub>gs</sub> = 0V	—	1700	—	mS
I <sub>dss</sub>	V <sub>ds</sub> = 2.0V, V <sub>gs</sub> = 0V	—	2.8	—	A
V <sub>p</sub>	V <sub>ds</sub> = 3.0V, I <sub>ds</sub> = 65 mA	—	-1.8	—	Volts
BV <sub>GD</sub> (3)	I <sub>gd</sub> = 6.5 mA	18	20	—	Volts
θ <sub>JL</sub> (2)	@ 150°C TCH	—	10	—	°C/W

### Notes:

1. Sum to two tones with 1 MHz spacing = 29 dBm.
2. See thermal considerations information on page 4.
3. Max (+V<sub>d</sub>) and (-V<sub>g</sub>) under linear operation. Max potential difference across the device in RF compression (2V<sub>d</sub> + |-V<sub>g</sub>|) not to exceed the minimum breakdown voltage (V<sub>br</sub>) of +18V.

### Absolute Maximum Ratings

Parameter	Symbol	Rating
Drain-Source Voltage	V <sub>DS</sub>	12V (3)
Gate-Source Voltage	V <sub>GS</sub>	-5V
Drain Current	I <sub>DS</sub>	I <sub>dss</sub>
Continuous Dissipation	P <sub>T</sub>	10W
Channel Temperature	T <sub>CH</sub>	175°C
Storage Temperature	T <sub>STG</sub>	-65°C to +175°C

### SO-8 Power Package Physical Dimensions

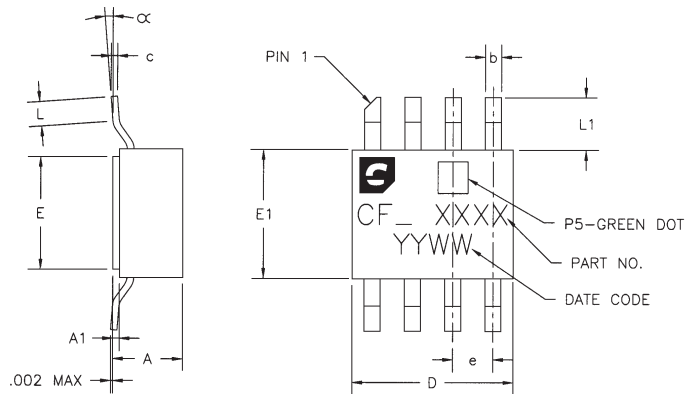

DIMENSION	MINIMUM	NOMINAL	MAXIMUM
A		.086[2.184]	.100[2.540]
A1	.005[.1270]	.008[.2032]	.011[.2794]
b	.017[.4318]	.020[.5080]	.023[.5842]
c	.007[.1778]	.008[.2032]	.009[.2286]
D	.195[4.953]	.200[5.080]	.205[5.207]
E	.135[3.429]	.140[3.556]	.145[3.683]
E1	.155[3.937]	.160[4.064]	.165[4.191]
e		.050[1.270]	
L	.020[.5080]		.040[1.016]
L1	.055[1.397]	.065[1.651]	.075[1.905]
α	0°		8°

DIMENSIONS IN INCHES [MILLIMETERS]

## Typical Scattering Parameters (TA = 25°C, Vds = 5 V, Ids = 350 mA)

Frequency (GHz)	S <sub>11</sub>		S <sub>21</sub>		S <sub>12</sub>		S <sub>22</sub>	
	Mag	Ang	Mag	Ang	Mag	Ang	Mag	Ang
0.6	0.946	-162.45	4.973	86.73	0.017	11.14	0.739	172.95
1.0	0.946	-176.06	2.885	73.75	0.018	9.37	0.748	169.73
1.8	0.927	172.61	1.873	54.47	0.023	1.6	0.707	161.84
1.9	0.922	169.71	1.828	50.82	0.023	-0.79	0.70	158.98
1.5	0.938	178.31	2.055	63.25	0.02	4.93	0.73	167.15
2.0	0.918	166.09	1.777	46.63	0.025	-1.23	0.694	155.54
2.1	0.914	161.9	1.722	42.23	0.024	-4.64	0.69	151.93
2.2	0.912	157.79	1.664	37.59	0.026	-9.26	0.689	148.15
2.3	0.914	153.46	1.578	34.07	0.023	-17.03	0.703	143.83
2.4	0.914	148.95	1.503	29.83	0.023	-21.0	0.707	139.91
2.5	0.918	145.37	1.431	26.13	0.023	-22.87	0.714	137.02
2.6	0.921	141.59	1.344	22.16	0.022	-28.45	0.722	134.0
2.7	0.923	138.23	1.254	18.61	0.022	-28.3	0.735	131.62
3.0	0.941	132.34	1.033	10.11	0.022	-27.73	0.76	128.69
3.5	0.957	134.66	0.803	6.12	0.02	-21.78	0.787	132.92
4.0	0.94	138.76	0.803	1.66	0.023	-20.57	0.74	136.51

## (TA = 25°C, Vds = 5 V, Ids = 1200 mA)

0.6	0.95	-165	5.311	84.94	0.014	13.61	0.747	17.19
1.0	0.951	-177.94	3.044	72.23	0.014	14.39	0.749	168.92
1.8	0.935	171.39	1.98	53.44	0.018	10.27	0.703	161.07
1.9	0.931	168.6	1.93	49.72	0.019	5.75	0.696	158.27
2.0	0.929	165.15	1.88	45.76	0.02	7.43	0.69	154.9
2.1	0.925	161.29	1.822	41.44	0.02	4.37	0.686	151.32
2.2	0.924	157.02	1.757	36.86	0.021	2.36	0.687	147.44
2.3	0.92	152.84	1.765	32.59	0.02	-5.07	0.679	144.99
2.4	0.923	148.35	1.673	28.03	0.021	-71.14	0.684	141.21
2.5	0.923	144.9	1.603	24.44	0.021	-9.31	0.692	138.25
2.6	0.927	141.0	1.503	20.51	0.02	-11.55	0.702	135.31
2.7	0.93	137.72	1.406	16.94	0.02	-14.27	0.711	132.91
3.0	0.947	131.72	1.09	9.25	0.018	-17.77	0.757	127.79
3.5	0.961	133.41	0.853	4.59	0.017	-13.03	0.779	131.26
4.0	0.945	137.83	0.85	0.36	0.021	-8.72	0.73	134.73

## (TA = 25°C, Vds = 8 V, Ids = 800 mA)

0.6	0.941	-164.65	5.654	83.55	0.015	10.74	0.676	174.61
1.0	0.947	-177.32	3.25	70.11	0.015	8.2	0.688	171.96
1.8	0.93	171.59	2.058	49.6	0.018	6.89	0.652	165.68
1.9	0.927	168.63	2.006	45.54	0.019	3.81	0.644	163.07
2.0	0.923	165.04	1.99	41.52	0.019	-1.07	0.639	159.85
2.1	0.919	160.94	1.885	36.76	0.02	-1.68	0.635	156.23
2.2	0.917	156.65	1.714	32.35	0.02	-2.32	0.636	152.38
2.3	0.921	153.49	1.779	29.48	0.018	-14.97	0.642	148.42
2.4	0.921	149.12	1.688	24.79	0.018	-16.28	0.648	144.43
2.5	0.925	145.41	1.616	21.01	0.017	-20.8	0.656	141.59
2.6	0.927	141.65	1.518	16.92	0.017	-23.5	0.667	138.37
2.7	0.933	138.32	1.417	13.24	0.017	-25.79	0.681	136.05
3.0	0.944	131.73	1.116	3.58	0.018	-21.43	0.722	132.33
3.5	0.96	134.09	0.857	-1.39	0.016	-16.54	0.762	136.36
4.0	0.942	137.96	0.841	-6.32	0.02	-10.57	0.723	140.71

**RF Match** Data shown in the performance graphs was taken in the test circuits shown at right and on page 3. Layout is important for proper operation. Phase length of input and output 50Ω line varies as a function of exact desired frequency of operation. Output shunt inductor effects output performance. Celeritek recommends the use of a high impedance printed inductor Lambda/4 in length. Please contact the factory for an evaluation board and/or more detailed application support.

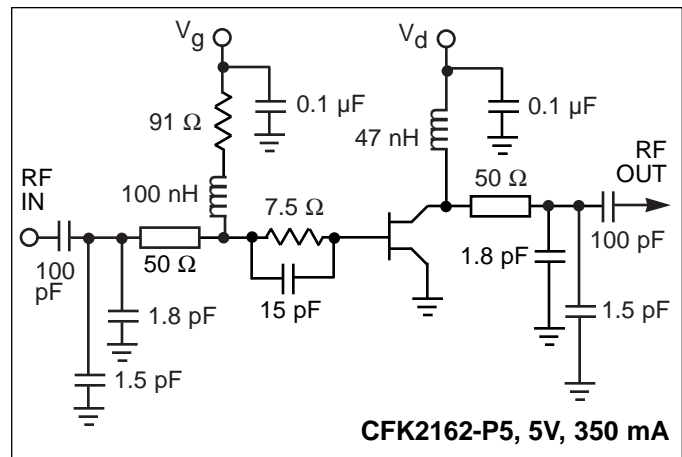



## Typical Performance

**Power Output & Power Added Efficiency vs Power Input**  
2.45 GHz,  $V_{DS} = 8\text{ V}$ ,  $I_{DS} = 800\text{ mA}$

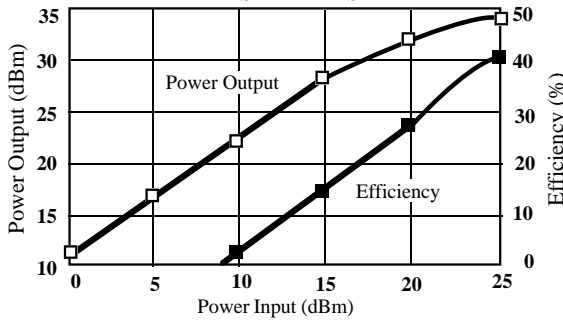

**Power Output & Power Added Efficiency vs Power Input**  
2.45 GHz,  $V_{DS} = 5\text{ V}$ ,  $I_{DS} = 1.2\text{ A}$

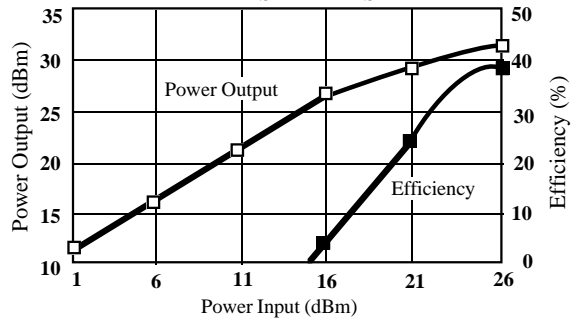

**Power Output and Gain vs Frequency**  
 $V_{DS} = 8\text{ V}$ ,  $I_{DS} = 800\text{ mA}$

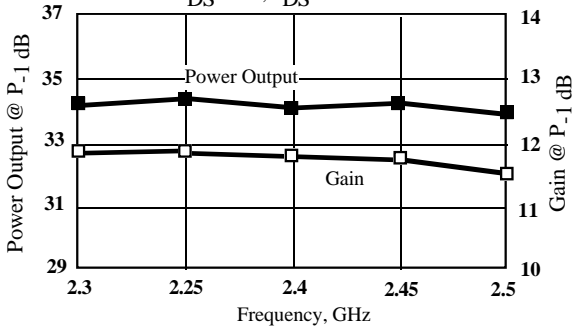

**Power Output and Gain vs Frequency**  
 $V_{DS} = 5\text{ V}$ ,  $I_{DS} = 1200\text{ mA}$

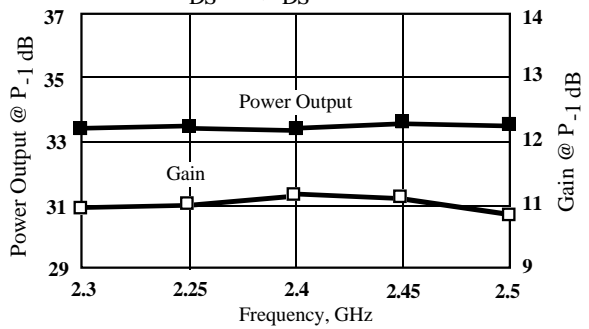

**Power Output & 3rd Order Products vs Power Input**  
2.45 GHz,  $V_{DS} = 8\text{ V}$ ,  $I_{DS} = 800\text{ mA}$

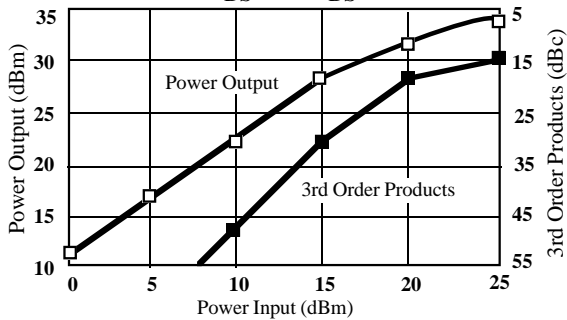

**Power Output & 3rd Order Products vs Power Input**  
2.45 GHz,  $V_{DS} = 5\text{ V}$ ,  $I_{DS} = 1.2\text{ A}$

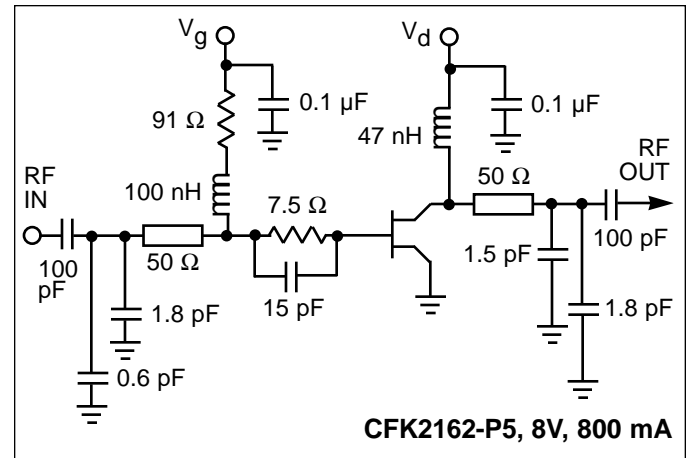
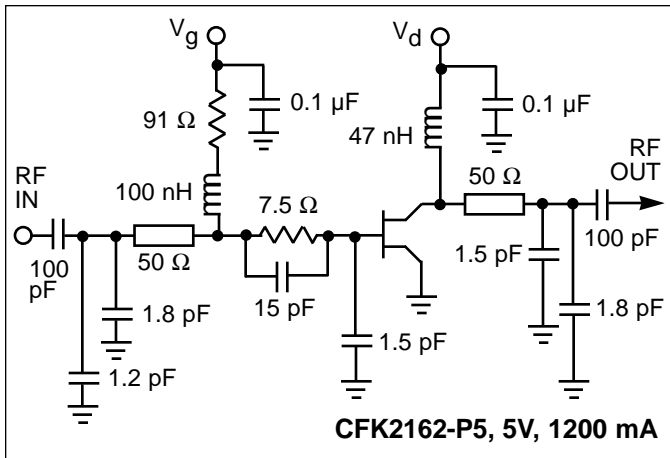
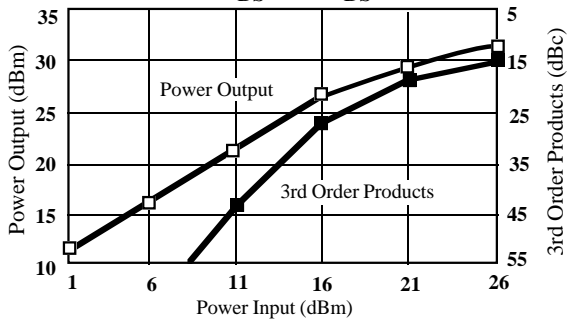

## Thermal Considerations

The data shown was taken on a 31 mil thick FR-4 board with 1 ounce copper on both sides. The board was mounted to a baseplate with 3 screws as shown. The screws bring the top side copper temperature to the same value as the baseplate. The thermal resistance to the indicated reference lead,  $\Theta_{JL}$ , is 10°C/W. The thermal resistance to the reference screw is 12°C/W.

1. Use 1 or 2 ounce copper if possible.
2. Solder all eight leads of the CFK2162-P5 package to the appropriate electrical connection.
3. Solder the copper pad on the backside of the CFK2162-P5 package to the ground plane.
4. Use a large ground pad area with many plated through-holes as shown.
5. If possible, use at least one screw no more than 0.2 inches from the CFK2162-P5 package to provide a low thermal resistance path to the baseplate of the package.

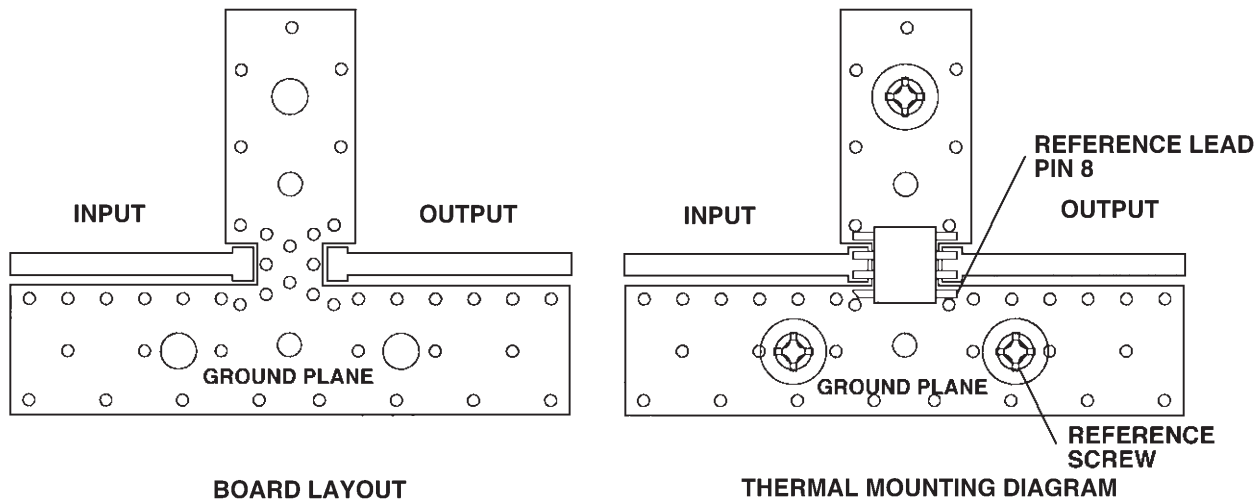

## Ordering Information

The CFK2162-P5 power stage is available in a SO-8 surface mount package. Devices are available in tape and reel. Ordering part numbers are listed.

<u>Part Number for Ordering</u>	<u>Function</u>	<u>Package</u>
<b>CFK2162-P5</b>	<b>2.3 - 2.5 GHz Power Stage</b>	<b>SO-8 surface mount power package</b>
<b>CFK2162-P5-000T</b>	<b>2.3 - 2.5 GHz Power Stage</b>	<b>SO-8 surface mount power package in tape and reel</b>

Celeritek reserves the right to make changes without further notice to any products herein. Celeritek makes no warranty, representation or guarantee regarding the suitability of its products for any particular purpose, nor does Celeritek assume any liability arising out of the application or use of any product or circuit, and specifically disclaims any and all liability, including without limitation consequential or incidental damages. "Typical" parameters can and do vary in different applications. All operating parameters, including "Typicals" must be validated for each customer application by customer's technical experts. Celeritek does not convey any license under its patent rights nor the rights of others. Celeritek products are not designed, intended, or authorized for use as components in systems intended for surgical implant into the body, or other applications intended to support or sustain life, or for any other application in which the failure of the Celeritek product could create a situation where personal injury or death may occur. Should Buyer purchase or use Celeritek products for any such unintended or unauthorized application, Buyer shall indemnify and hold Celeritek and its officers, employees, subsidiaries, affiliates, and distributors harmless against all claims, costs, damages, and expenses, and reasonable attorney fees arising out of, directly or indirectly, any claim of personal injury or death associated with such unintended or unauthorized use, even if such claim alleges that Celeritek was negligent regarding the design or manufacture of the part. Celeritek is a registered trademark of Celeritek, Inc. Celeritek, Inc. is an Equal Opportunity/Affirmative Action Employer.