

ISSUE 13; April 2016

**Description**

- Sub 1ppm performance TCXO, a single chip oscillator and analogue compensation circuit operating over an extended temperature range. Its ability to function down to a supply voltage of 2.4V and low power consumption make it particularly suitable for mobile applications.
- 1A No ref voltage, ageing adj option
- 1B No ref voltage, no freq adj option
- 2A Ref voltage = 2.2V, ageing adj option
- 3A Ref voltage = 2.7V, ageing adj option



**Frequency Parameters**

- Frequency: 10.0MHz to 40.0MHz
- Frequency Stability:  $\pm 0.30\text{ppm}$  to  $\pm 2.50\text{ppm}$
- Ageing:  $\pm 2\text{ppm}$  max in 1st year

**Electrical Parameters**

- Supply Voltage: 3.3V  $\pm 10\%$
- Supply Current: 1+Frequency(MHz) \* 1.2\*(Load(pF)+30)\*10-3mA
- Supply voltages in the range 2.4V to 6.0V available to order, please contact our sales offices
- Optional reference voltage output on pad 1, suitable for potentiometer supply or DAC reference:
  - No output (standard option)
  - 2.2V, for Min. VS>2.4V
  - 2.7V, for Min. VS>3.0V
 Maximum load current (mA) = Vref/10
- For manual frequency adjustment connect an external 50k $\Omega$  potentiometer between pad 1 (Reference Voltage) and pad 4 (GND) with wiper connected to pad 10 (Voltage Control). Please specify reference voltage as part of the ordering code.

**Frequency Adjustment**

- Three options with external Voltage Control applied to pad 10:
  - Ageing Adjustment:
    - > $\pm 5\text{ppm}$ , frequency <20MHz
    - > $\pm 7\text{ppm}$ , frequency >20MHz
  - No frequency adjustment initial calibration @ 25°C <  $\pm 1.0\text{ppm}$
  - High Pulling  $\pm 10\text{ppm}$  to  $\pm 50\text{ppm}$  can be available depending on frequency and stability options (please contact our sales offices)
- Linearity: <1%
- Slope: Positive
- Input Resistance: >100k $\Omega$
- Modulation Bandwidth: >2kHz
- Voltage Control Range:
  - Without reference voltage: 1.65V $\pm 1\text{V}$
  - With reference voltage: Vc = 0V to Vref
- Ageing:
  - $\pm 1\text{ppm}$  maximum in 1st year, frequency <20MHz
  - $\pm 3\text{ppm}$  maximum for 10 years (including the 1st year), frequency <20MHz
  - $\pm 2\text{ppm}$  maximum in 1st year, frequency  $\geq 20\text{MHz}$
  - $\pm 5\text{ppm}$  maximum for 10 years (including the 1st year), frequency  $\geq 20\text{MHz}$
- After Reflow:  $\pm 1\text{ppm}$  max

**Outline (mm) -1A = No ref voltage, ageing adj option**

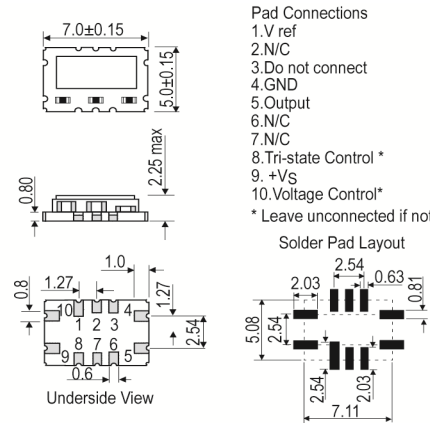

- Pad Connections
- 1.V ref
  - 2.N/C
  - 3.Do not connect
  - 4.GND
  - 5.Output
  - 6.N/C
  - 7.N/C
  - 8.Tri-state Control \*
  - 9.+Vs
  - 10.Voltage Control\*
- \* Leave unconnected if not required

**Solder Pad Layout**

**Test Circuit**

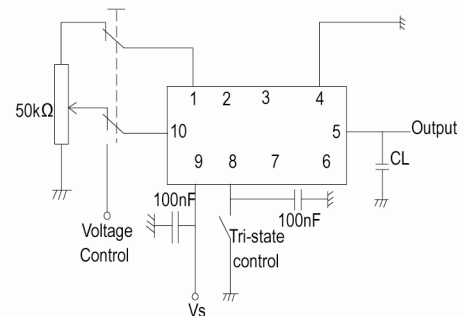

**Sales Office Contact Details:**

UK: +44 (0)1460 270200  
Germany: 0800 1808 443

France: 0800 901 383  
USA: +1.760.318.2824

Email: [info@iqdfrequencyproducts.com](mailto:info@iqdfrequencyproducts.com)  
Web: [www.iqdfrequencyproducts.com](http://www.iqdfrequencyproducts.com)

#### Operating Temperature Ranges

- 0 to 50°C
- -20 to 70°C
- 0 to 70°C
- -30 to 75°C
- -40 to 85°C

#### Output Details

- Output Compatibility                      Clipped Sine
- Load: 10kΩ // 10pF, AC-coupled

#### Output Control

- Tri-state Operation:  
Logic '1' (>60% Vs) to pad 8 enables output  
Logic '0' (<20% Vs) to pad 8 disables output  
When at logic '0' the output stage is disabled for all output options, but the oscillator and compensation circuit are still active (current consumption <1mA)

#### Output Levels

- Vpk-pk > 0.8V

#### Noise Parameters

- Phase Noise Typical (@ 13.0MHz):  
Offset    dBc/Hz  
10Hz    -95  
100Hz   -120  
1kHz    -135  
10kHz   -140  
100kHz  -145

#### Environmental Parameters

- Storage Temperature Range: -55 to 125°C
- Shock: IEC 60068-2-27, Test Ea: 1500G acceleration for 6ms, 3 shocks in each of 3 mutually perpendicular planes
- Vibration: IEC 60068-2-6, Test Fc, Procedure B4: 10Hz-60Hz, 1.5mm displacement, 60-2000Hz at 98.1m/s<sup>2</sup>, 30mins in 3 mutually perpendicular planes at 1 oct/min
- Solderability: MIL-STD-202, Method 208, Category 3

#### Ordering Information

- Frequency\*  
Model\*  
Reference Voltage + Frequency Adjustment Options\*  
Output  
Frequency Stability (over operating temperature range)\*  
Operating Temperature Range\*  
Supply Voltage  
(\*minimum required)
- Example  
10.0MHz CFPT-9008-1A  
Clipped Sine ±1.0ppm -20 to 70C 3.3V
- Note: Certain frequency stability / temperature range combinations may not be available for all frequencies.

#### Compliance

- RoHS Status (2011/65/EU)              Compliant
- REACh Status                                Compliant
- MSL Rating (JDEC-STD-033):            1

#### Sales Office Contact Details:

UK: +44 (0)1460 270200  
Germany: 0800 1808 443

France: 0800 901 383  
USA: +1.760.318.2824

Email: [info@iqdfrequencyproducts.com](mailto:info@iqdfrequencyproducts.com)  
Web: [www.iqdfrequencyproducts.com](http://www.iqdfrequencyproducts.com)

**Packaging Details**

- Pack Style: Reel      Tape & reel in accordance with EIA-481-D  
Pack Size: 1,000
- Pack Style: Bulk      Loose in bulk pack  
Pack Size: 10

**Electrical Specification - maximum limiting values 3.3V ±10%**

Frequency Min	Frequency Max	Temperature Range	Stability (Min)	Current Draw	Rise and Fall Time	Duty Cycle
		°C	ppm	mA	ns	%
10.0MHz	40.0MHz	0 to 70	±0.3	-	-	-
		-20 to 70	±0.5	-	-	-
		-30 to 75	±1.0	-	-	-
		-40 to 85	±1.0	-	-	-

*This document was correct at the time of printing; please contact your local sales office for the latest version.*  
[Click to view latest version on our website.](#)

**Sales Office Contact Details:**

UK: +44 (0)1460 270200  
Germany: 0800 1808 443

France: 0800 901 383  
USA: +1.760.318.2824

Email: [info@iqdfrequencyproducts.com](mailto:info@iqdfrequencyproducts.com)  
Web: [www.iqdfrequencyproducts.com](http://www.iqdfrequencyproducts.com)