

CGH35060F1/P1

60 W, 3.3-3.6 GHz, 28V, GaN HEMT for WiMAX,
Broadband Wireless Access

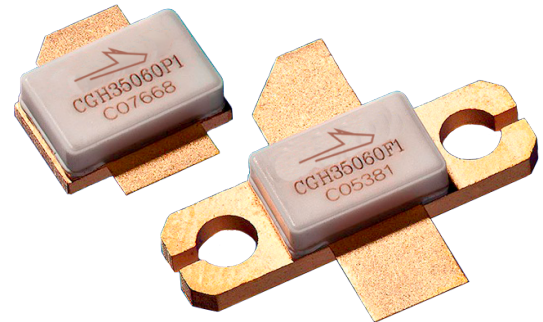

Package Types: 440193 and 440196
PNs: CGH35060F1 and CGH35060P1

Description

WolfSpeed's CGH35060F F1/P1 is a gallium nitride (GaN) high electron mobility transistor (HEMT) designed specifically for high efficiency, high gain and wide bandwidth capabilities, which makes the CGH35060F ideal for 3.3-3.6 GHz WiMAX and BWA linear amplifier applications. The transistor is supplied in a ceramic/metal flange and pill package. WolfSpeed GaN-on-Silicon Carbide instead HEMTs are highly correctable, enabling even greater efficiency when used with digital pre-distortion (DPD).

Typical Performance Over 3.3-3.6 GHz ($T_c = 25^\circ\text{C}$) of Demonstration Amplifier

Parameter	3.3 GHz	3.4 GHz	3.5 GHz	3.6 GHz	Units
Small Signal Gain	11.7	12.2	12.6	12.8	dB
EVM @ 26 dBm	2.05	1.82	1.56	1.80	%
EVM @ 39 dBm	1.91	1.83	1.98	2.86	%
Drain Efficiency @ 39 dBm	22.0	23.1	24.9	26.7	%
Input Return Loss	8.0	10.3	12.5	13.1	dB

Note:

Measured in the CGH35060F1-AMP amplifier circuit, under 802.16 OFDM, 3.5 MHz Channel BW, 1/4 Cyclic Prefix, 64 QAM Modulated Burst, 5ms Burst, Symbol Length of 59, Coding Type RS-CC, Coding Rate Type 2/3, PAR = 9.8 dB @ 0.01% Probability on CCDF.

Features

- 3.3 - 3.6 GHz Operation
- 60 W Peak Power Capability
- 12 dB Small Signal Gain
- 8.0 W P_{AVE} at < 2.0% EVM
- 25% Drain Efficiency at 8 W P_{AVE}
- WiMAX Fixed Access 802.16-2004 OFDM
- WiMAX Mobile Access 802.16e OFDMA

 Large Signal Models Available for ADS and MWO





Absolute Maximum Ratings (not simultaneous) at 25°C Case Temperature

Parameter	Symbol	Rating	Units	Conditions
Drain-Source Voltage	V_{DS}	120	V	25°C
Gate-to-Source Voltage	V_{GS}	-10, +2		
Power Dissipation	P_{DISS}	28	W	
Storage Temperature	T_{STG}	-65, +150	°C	
Operating Junction Temperature	T_J	225		
Maximum Forward Gate Current	I_{GMAX}	15	mA	25°C
Maximum Drain Current ¹	I_{DMAX}	6	A	
Soldering Temperature ²	T_S	245	°C	
Screw Torque	τ	40	in-oz	
Thermal Resistance, Junction to Case ³	$R_{\theta JC}$	2.8	°C/W	85°C
Case Operating Temperature ³	T_C	-40, +150	°C	

Notes:

¹ Current limit for long term, reliable operation

² Refer to the Application Note on soldering at wolfspeed.com/rf/document-library

³ Measured for the CGH35060F1 at $P_{DISS} = 28$ W.

Electrical Characteristics ($T_c = 25^\circ\text{C}$)

Characteristics	Symbol	Min.	Typ.	Max.	Units	Conditions
DC Characteristics¹						
Gate Threshold Voltage	$V_{GS(th)}$	-3.8	-3.0	-2.3	V_{DC}	$V_{DS} = 10$ V, $I_D = 14.4$ mA
Gate Quiescent Voltage	$V_{GS(Q)}$	–		–		$V_{DS} = 28$ V, $I_D = 250$ mA
Saturated Drain Current	I_{DS}	11.6	14.0	–	A	$V_{DS} = 6$ V, $V_{GS} = 2$ V
Drain-Source Breakdown Voltage	V_{BR}	84	–	–	V_{DC}	$V_{GS} = -8$ V, $I_D = 14.4$ mA
RF Characteristics^{2,3} ($T_c = 25^\circ\text{C}$, $F_0 = 3.5$ GHz unless otherwise noted)						
Small Signal Gain	G_{SS}	10	11.5	–	dB	$V_{DD} = 28$ V, $I_{DQ} = 250$ mA
Drain Efficiency ⁴	η	19	23	–	%	$V_{DD} = 28$ V, $I_{DQ} = 250$ mA, $P_{AVE} = 8$ W
Back-Off Error Vector Magnitude	EVM	–	2.5	–		$V_{DD} = 28$ V, $I_{DQ} = 250$ mA, $P_{AVE} = 24$ dBm
Error Vector Magnitude		–	2.0	2.5		$V_{DD} = 28$ V, $I_{DQ} = 250$ mA, $P_{AVE} = 8$ W
Output Mismatch Stress	VSWR	–	–	10:1	Ψ	No damage at all phase angles, $V_{DD} = 28$ V, $I_{DQ} = 250$ mA
Dynamic Characteristics						
Input Capacitance	C_{GS}	–	19.0	–	pF	$V_{DS} = 28$ V, $V_{GS} = -8$ V, $f = 1$ MHz
Output Capacitance	C_{DS}	–	5.9	–		
Feedback Capacitance	C_{GD}	–	0.8	–		

Notes:

¹ Measured on wafer prior to packaging.

² Measured in the CGH35060F1-AMP test fixture

³ Under 802.16 OFDM, 3.5 MHz Channel BW, 1/4 Cyclic Prefix, 64 QAM Modulated Burst, 5ms Burst, Symbol Length of 59, Coding Type RS-CC, Coding RateType 2/3, PAR = 9.8 dB @ 0.01% Probability on CCDF

⁴ Drain Efficiency = P_{OUT} / P_{DC}



Typical WiMAX Performance

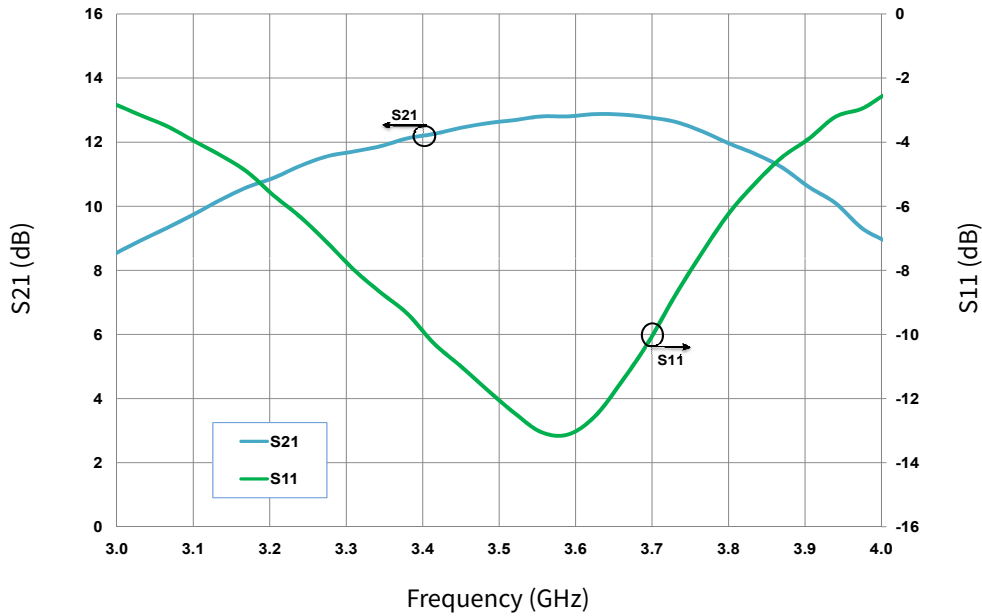

Figure 1. Gain and Return Loss vs Frequency measured in Broadband Amplifier Circuit CGH35060F1-AMP
 $V_{DD} = 28\text{ V}$, $I_{DQ} = 250\text{ mA}$

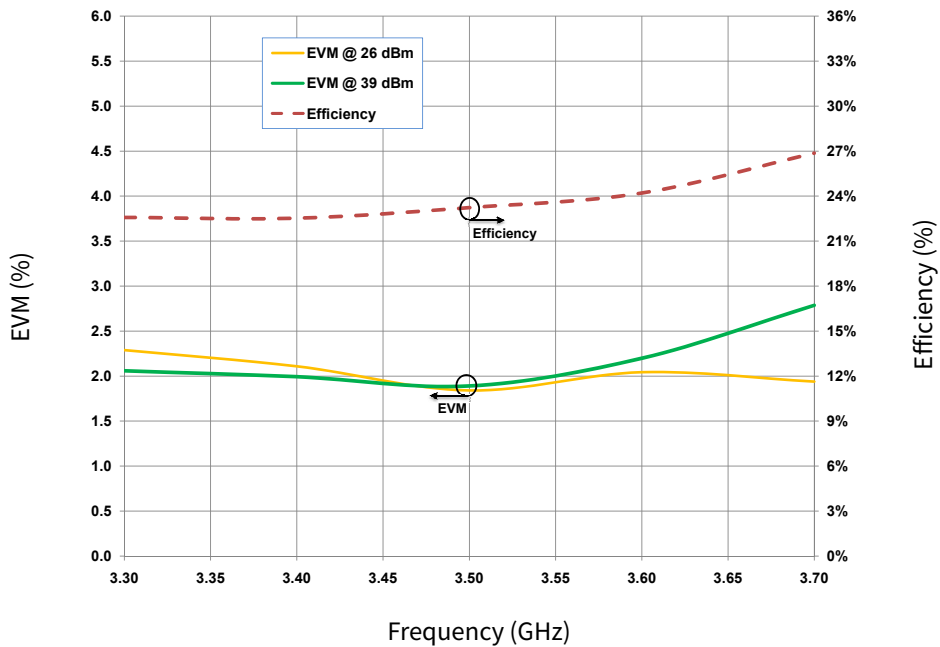

Figure 2. Typical EVM at 26 dBm and 39 dBm, and Efficiency vs Frequency measured in Broadband Amplifier Circuit CGH35060F1-AMP
 $V_{DD} = 28\text{ V}$, $I_{DQ} = 250\text{ mA}$

Note:

¹ 802.16-2004 OFDM, 3.5 MHz Channel BW, 1/4 Cyclic Prefix, 64 QAM Modulated Burst, Symbol Length of 59, Coding Type RS-CC, Coding Rate Type 2/3



Typical WiMAX Performance

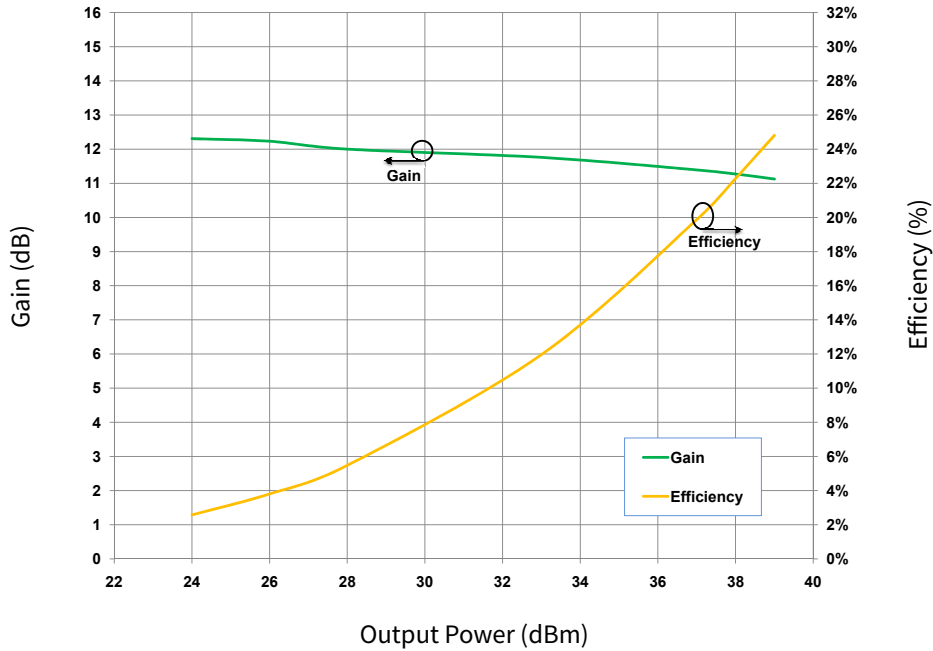

Figure 3. Drain Efficiency and Gain vs Output Power measured in the CGH35060F1-AMP
 $V_{DD} = 28\text{ V}$, $I_{DQ} = 250\text{ mA}$, 802.16-2004 OFDM, PAR = 9.8 dB

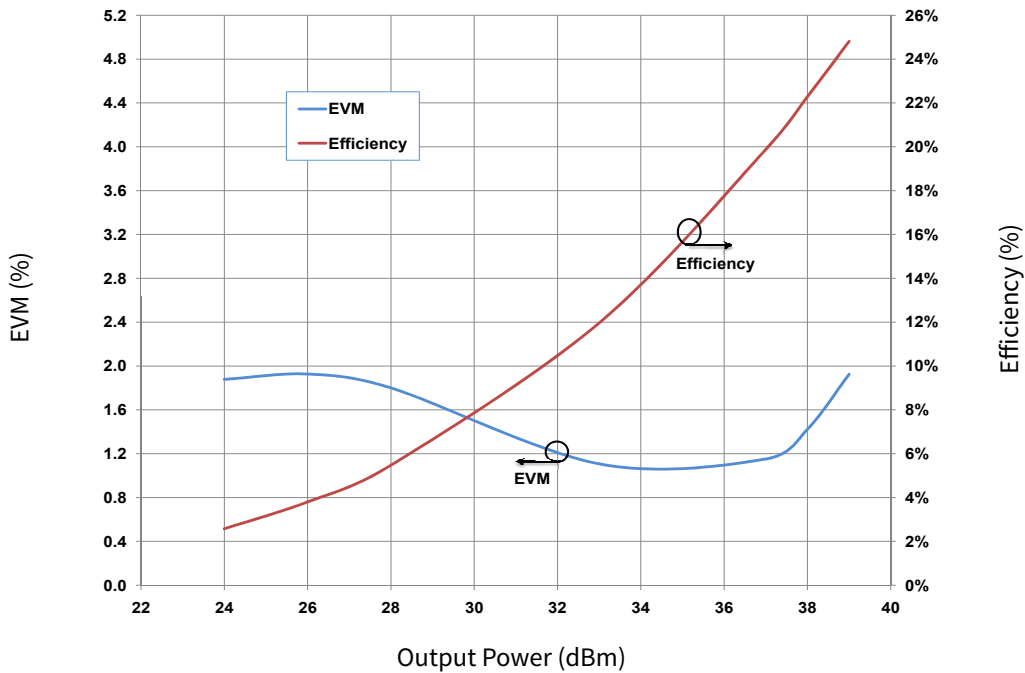

Figure 4. Typical EVM and Efficiency vs Output Power measured in the CGH35060F1-AMP
 $V_{DD} = 28\text{ V}$, $I_{DQ} = 250\text{ mA}$, 802.16-2004 OFDM, PAR=9.8 dB

Note:

¹ Under 802.16-2004 OFDM, 3.5 MHz Channel BW, 1/4 Cyclic Prefix, 64 QAM Modulated Burst, Symbol Length of 59, Coding Type RS-CC, Coding Rate Type 2/3



Typical Performance

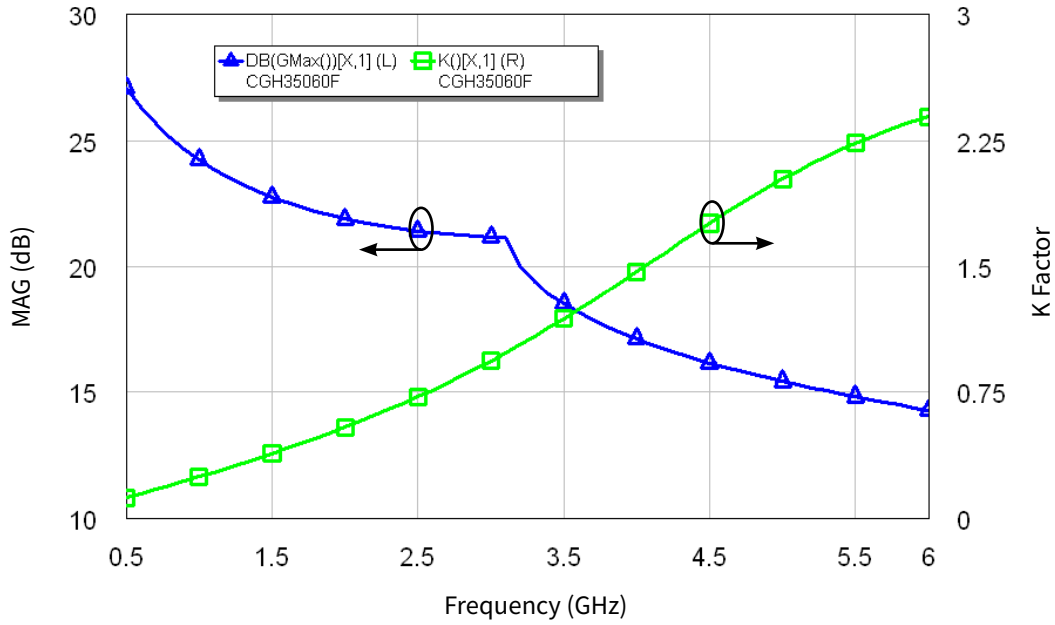

Figure 5. Simulated Maximum Available Gain and K Factor of the CGH35060F1 and CGH35060P1
 $V_{DD} = 28\text{ V}$, $I_{DQ} = 250\text{ mA}$

Typical Noise Performance

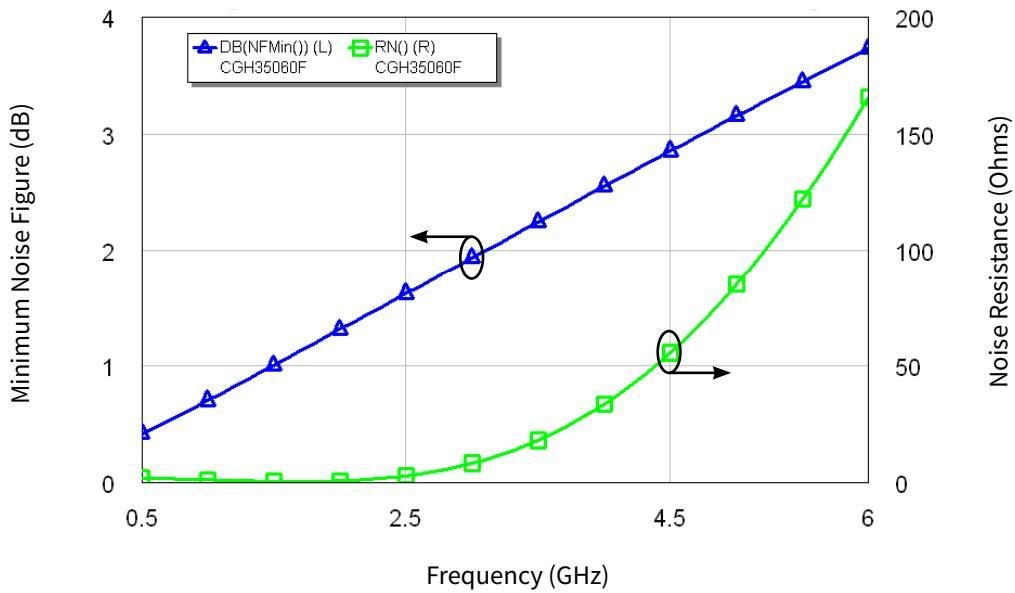
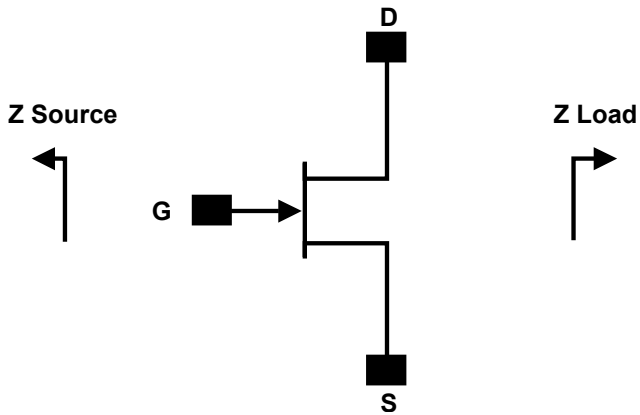

Figure 6. Simulated Minimum Noise Figure and Noise Resistance vs Frequency of the CGH35060
 $V_{DD} = 28\text{ V}$, $I_{DQ} = 250\text{ mA}$



Source and Load Impedances



Frequency (MHz)	Z Source	Z Lead
3300	3.5 - j12.1	6.5 - j6.8
3400	3.5 - j11.4	6.0 - j5.9
3500	3.3 - j10.7	5.6 - j5.1
3600	3.2 - j10.0	5.4 - j4.3

Notes:

¹ $V_{DD} = 28V$, $I_{DQ} = 250mA$ in the 440193 package

² Impedances are extracted from the CGH35060F1-AMP demonstration amplifier and are not source and load pull data derived from the transistor

Electrostatic Discharge (ESD) Classifications

Parameter	Symbol	Class	Classification Level	Test Methodology
Human Body Model	HBM	TBD	ANSI/ESDA/JEDEC JS-001 Table 3	JEDEC JESD22 A114-D
Charge Device Model	CDM	TBD	ANSI/ESDA/JEDEC JS-002 Table 3	JEDEC JESD22 C101-C



CGH35060F1-AMP Demonstration Amplifier Circuit Bill of Materials

Designator	Description	Qty
R1	RES, 1/16W, 0603, 1%, 5.1 OHMS	1
R2	RES, 1/16W, 0603, 1%, 100 OHMS	1
C6,C13,C19	CAP, 470pF, 5%,100V, 0603	3
C16,C22	CAP, 33μF, 20%, G CASE	2
C15,C21	CAP, 1.0μF, 100V, 10%, X7R, 1210	2
C8	CAP 10μF 16V TANTALUM	1
C4,C11,C17	CAP, 7.5pF, +/-0.1pF, 0603, ATC	3
C1	CAP, 0.6pF, +/-0.05pF, 0603, ATC	2
C2	CAP, 1.2pF, +/-0.1pF, 0603, ATC	1
C10	CAP, 4.7pF, +/-0.25pF, 100B, ATC	3
C5,C12,C18,C30,C31	CAP, 47pF, +/-5%, 0603, ATC	5
C7,C14.C20	CAP, 33000pF, 0805, 100V, X7R	2
J2,J3	CONN, SMA, PANEL MOUNT JACK, FLANGE	2
J1	HEADER RT>PLZ .1CEN LK 5POS	1
Q1	CGH35060F1	1

CGH35060F1-AMP Demonstration Amplifier Circuit Schematic

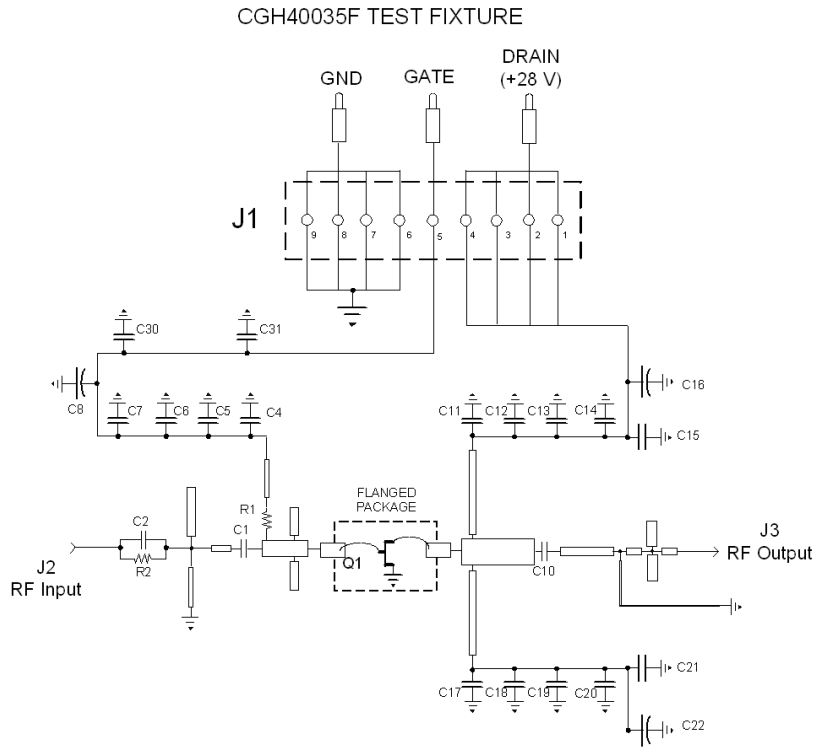

CGH35060F1-AMP Demonstration Amplifier Circuit Outline

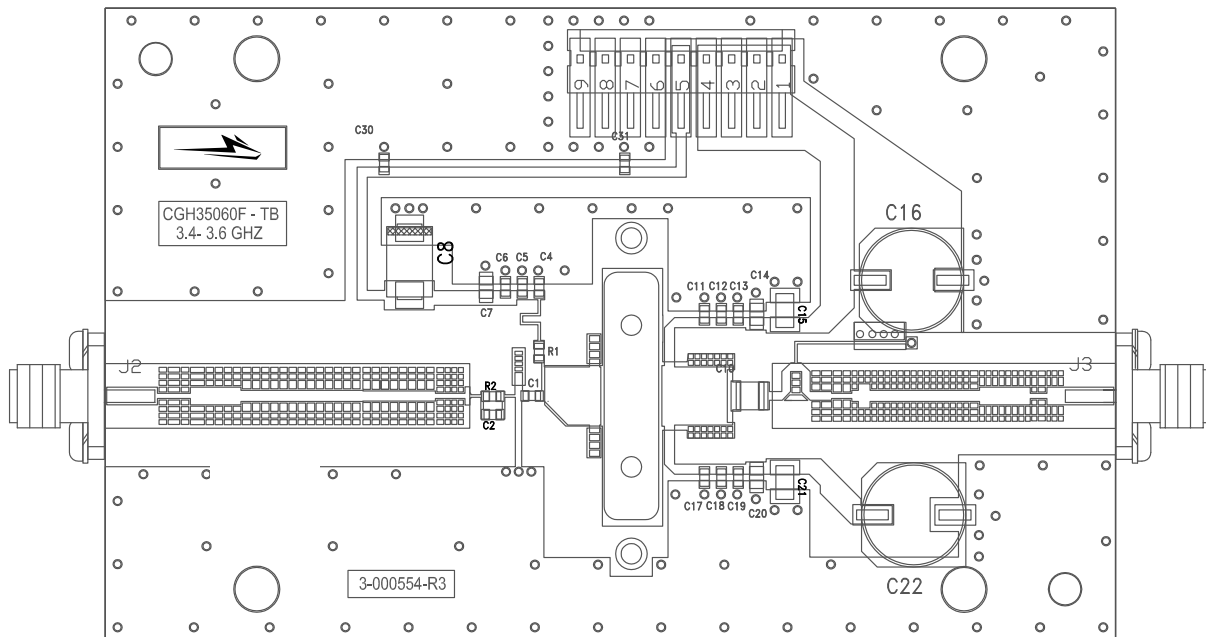



Typical Package S-Parameters for CGH35060F1/P1
(Small Signal, $V_{DS} = 28$ V, $I_{DQ} = 250$ mA, angle in degrees)

Frequency	Mag S11	Ang S11	Mag S21	Ang S21	Mag S12	Ang S12	Mag S22	Ang S22
500 MHz	0.932	-170.73	7.26	79.93	0.014	-5.48	0.616	-170.30
600 MHz	0.933	-173.14	6.04	75.95	0.014	-8.53	0.624	-170.60
700 MHz	0.933	-175.02	5.17	72.27	0.014	-11.26	0.632	-170.73
800 MHz	0.934	-176.56	4.51	68.80	0.014	-13.77	0.640	-170.79
900 MHz	0.935	-177.90	3.99	65.50	0.014	-16.12	0.648	-170.84
1.0 GHz	0.936	-179.09	3.58	62.32	0.014	-18.33	0.657	-170.91
1.1 GHz	0.937	179.82	3.24	59.24	0.013	-20.41	0.666	-171.02
1.2 GHz	0.937	178.80	2.96	56.27	0.013	-22.38	0.675	-171.18
1.3 GHz	0.938	177.82	2.73	53.38	0.013	-24.25	0.684	-171.38
1.4 GHz	0.939	176.88	2.53	50.57	0.013	-26.02	0.693	-171.64
1.5 GHz	0.940	175.95	2.35	47.83	0.012	-27.69	0.702	-171.94
1.6 GHz	0.941	175.04	2.20	45.17	0.012	-29.28	0.710	-172.30
1.7 GHz	0.942	174.13	2.07	42.56	0.012	-30.78	0.718	-172.69
1.8 GHz	0.942	173.22	1.96	40.01	0.012	-32.20	0.726	-173.13
1.9 GHz	0.943	172.30	1.86	37.51	0.012	-33.53	0.733	-173.60
2.0 GHz	0.943	171.37	1.77	35.06	0.011	-34.79	0.740	-174.11
2.1 GHz	0.944	170.42	1.69	32.65	0.011	-35.98	0.746	-174.64
2.2 GHz	0.944	169.44	1.62	30.28	0.011	-37.09	0.752	-175.21
2.3 GHz	0.944	168.44	1.56	27.94	0.011	-38.14	0.757	-175.80
2.4 GHz	0.944	167.42	1.51	25.63	0.011	-39.12	0.762	-176.41
2.5 GHz	0.944	166.35	1.47	23.33	0.011	-40.03	0.767	-177.05
2.6 GHz	0.944	165.25	1.43	21.06	0.010	-40.89	0.771	-177.70
2.7 GHz	0.944	164.10	1.39	18.79	0.010	-41.69	0.775	-178.38
2.8 GHz	0.943	162.90	1.36	16.52	0.010	-42.44	0.778	-179.08
2.9 GHz	0.943	161.64	1.34	14.25	0.010	-43.15	0.780	-179.81
3.0 GHz	0.942	160.32	1.32	11.97	0.010	-43.81	0.783	179.45
3.2 GHz	0.939	157.45	1.29	7.34	0.010	-45.03	0.786	177.90
3.4 GHz	0.936	154.21	1.29	2.56	0.010	-46.16	0.787	176.26
3.6 GHz	0.932	150.50	1.30	-2.45	0.010	-47.28	0.786	174.50
3.8 GHz	0.926	146.18	1.32	-7.79	0.010	-48.49	0.783	172.62
4.0 GHz	0.918	141.08	1.37	-13.59	0.011	-49.93	0.778	170.58
4.2 GHz	0.907	134.91	1.45	-20.01	0.011	-51.79	0.770	168.35
4.4 GHz	0.893	127.31	1.55	-27.29	0.012	-54.34	0.759	165.88
4.6 GHz	0.875	117.74	1.68	-35.72	0.013	-57.92	0.745	163.12
4.8 GHz	0.851	105.40	1.85	-45.68	0.014	-62.99	0.726	159.95
5.0 GHz	0.821	89.23	2.06	-57.67	0.016	-70.09	0.701	156.25
5.2 GHz	0.788	67.93	2.29	-72.20	0.018	-79.82	0.668	151.81
5.4 GHz	0.763	40.72	2.50	-89.57	0.019	-92.51	0.624	146.32
5.6 GHz	0.760	8.85	2.62	-109.47	0.021	-107.92	0.563	139.43
5.8 GHz	0.789	-23.42	2.60	-130.80	0.021	-124.97	0.479	130.69
6.0 GHz	0.837	-51.66	2.44	-152.19	0.020	-142.29	0.367	119.31

To download the s-parameters in s2p format, go to the [CGH35060F1/P1 Product Page](#) and click on the documentation tab.



Product Dimensions CGH35060F1 (Package Type — 440193)

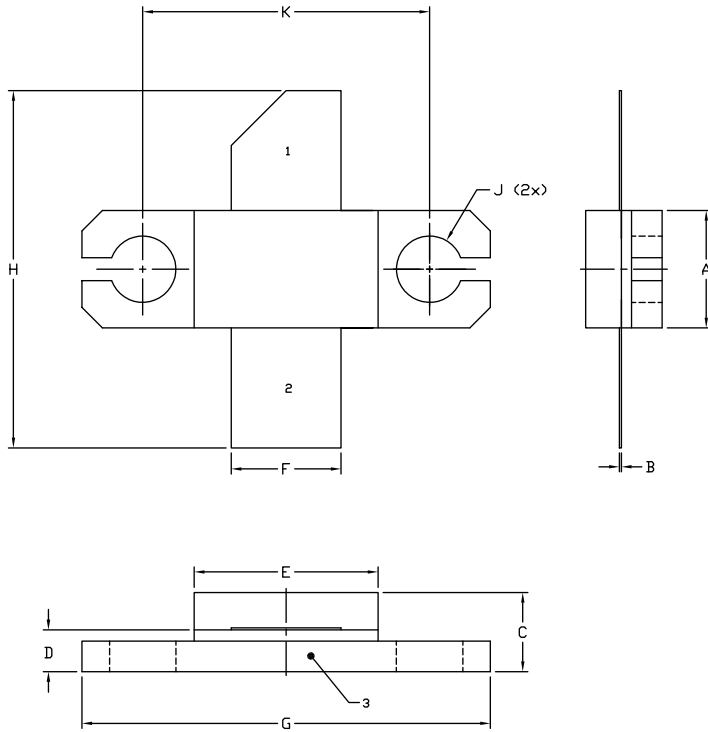

- NOTES:
1. DIMENSIONING AND TOLERANCING PER ANSI Y14.5M, 1982.
 2. CONTROLLING DIMENSION: INCH.
 3. ADHESIVE FROM LID MAY EXTEND A MAXIMUM OF 0.020" BEYOND EDGE OF LID.
 4. LID MAY BE MISALIGNED TO THE BODY OF THE PACKAGE BY A MAXIMUM OF 0.008" IN ANY DIRECTION.
 5. ALL PLATED SURFACES ARE Ni/AU

DIM	INCHES		MILLIMETERS	
	MIN	MAX	MIN	MAX
A	0.225	0.235	5.72	5.97
B	0.004	0.006	0.10	0.15
C	0.145	0.165	3.68	4.19
D	0.077	0.087	1.96	2.21
E	0.355	0.365	9.02	9.27
F	0.210	0.220	5.33	5.59
G	0.795	0.805	20.19	20.45
H	0.670	0.730	17.02	18.54
J	Ø .130		3.30	
k	0.562		14.28	

- PIN 1. GATE
 PIN 2. DRAIN
 PIN 3. SOURCE

Product Dimensions CGH35060P1 (Package Type — 440206)

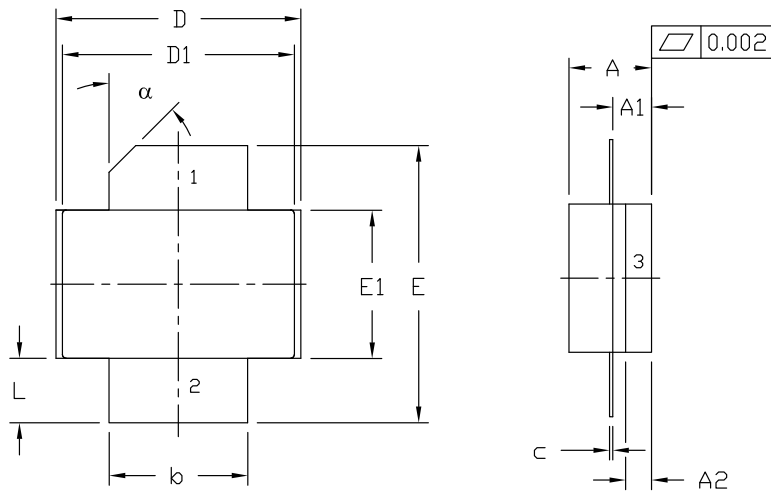

- NOTES:
1. DIMENSIONING AND TOLERANCING PER ANSI Y14.5M - 1994.
 2. CONTROLLING DIMENSION: INCH.
 3. ADHESIVE FROM LID MAY EXTEND A MAXIMUM OF 0.020" BEYOND EDGE OF LID.
 4. LID MAY BE MISALIGNED TO THE BODY OF PACKAGE BY A MAXIMUM OF 0.008" IN ANY DIRECTION.

DIM	INCHES		MILLIMETERS		NOTES
	MIN	MAX	MIN	MAX	
A	0.125	0.145	3.18	3.68	
A1	0.057	0.067	1.45	1.70	
A2	0.035	0.045	0.89	1.14	
b	0.210	0.220	5.33	5.59	2x
c	0.004	0.006	0.10	0.15	2x
D	0.375	0.385	9.53	9.78	
D1	0.355	0.365	9.02	9.27	
E	0.400	0.460	10.16	11.68	
E1	0.225	0.235	5.72	5.97	
L	0.085	0.115	2.16	2.92	2x
α	45° REF		45° REF		

- PIN 1. GATE
 PIN 2. DRAIN
 PIN 3. SOURCE

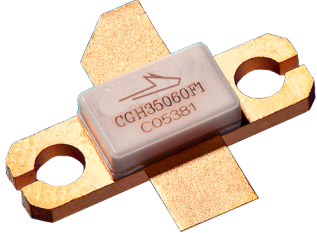
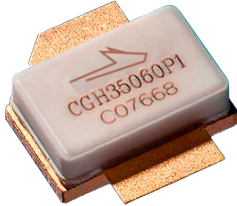

Product Ordering Information

Order Number	Description	Unit of Measure	Image
CGH35060F1	GaN HEMT	Each	 A photograph of a GaN HEMT device. It is a small, rectangular, light-colored component mounted on a gold-colored carrier with two circular holes. The device is marked with a stylized arrow logo and the text "CGH35060F1" and "C05381".
CGH35060P1	GaN HEMT	Each	 A photograph of a GaN HEMT device. It is a small, rectangular, light-colored component mounted on a gold-colored carrier. The device is marked with a stylized arrow logo and the text "CGH35060P1" and "C07668".
CGH35060F1-AMP	Test board with GaN HEMT installed	Each	

**For more information, please contact:**

4600 Silicon Drive
Durham, NC 27703 USA
Tel: +1.919.313.5300
www.wolfspeed.com/RF

Sales Contact
RFSales@wolfspeed.com

RF Product Marketing Contact
RFMarketing@wolfspeed.com

Notes & Disclaimer

Specifications are subject to change without notice. “Typical” parameters are the average values expected by Wolfspeed in large quantities and are provided for information purposes only. Wolfspeed products are not warranted or authorized for use as critical components in medical, life-saving, or life-sustaining applications, or other applications where a failure would reasonably be expected to cause severe personal injury or death. No responsibility is assumed by Wolfspeed for any infringement of patents or other rights of third parties which may result from use of the information contained herein. No license is granted by implication or otherwise under any patent or patent rights of Wolfspeed.

©2008-2022 Wolfspeed, Inc. All rights reserved. Wolfspeed® and the Wolfstreak logo are registered trademarks and the Wolfspeed logo is a trademark of Wolfspeed, Inc.
PATENT: <https://www.wolfspeed.com/legal/patents>

The information in this document is subject to change without notice.