



*Specification*

*For*

*LCD Module*

*CGM12864CSLK*

**Prepared:** \_\_\_\_\_

**Checked:** \_\_\_\_\_

**Approved:** \_\_\_\_\_



## CGM12864CSLK LCD MODULE

### 1. FEATURES

- 1.1 Display Type: STN
- 1.2 Display Mode: Green-yellow
- 1.3 Polarizer Mode: Transflective
- 1.4 Viewing Director: 6 O'clock
- 1.5 Driving Method: 1/64Duty, 1/9Bias
- 1.6 Backlight: LED (Yellow-Green)
- 1.7 Controller & Driver: PT6607-H&PT6608-H
- 1.8 Data Transfer: 8 Bit Parallel
- 1.9 Dot Matrix: 128X64Dots
- 1.10 Dot Size: 0.39X0.39(mm)
- 1.11 Dot Pitch: 0.43X0.43(mm)
- 1.12 Operating Temperature: 0°C~+50°C  
Storage Temperature: -20°C~+60°C

### 2. MECHANICAL PARAMETERS

Item	Description	Unit
LCM Outline Dimension	75.0X52.7X8.4	mm
Effective Viewing Area	60.2X32.8	mm
Weight	About 35	g

### 3. ELECTRICAL CHARACTERISTICS

Vdd=5V ± 5%, Vss=0, Ta=25

Item	Symbol	Test Condition	Min.	Typ.	Max.	Unit
Operating Voltage	Vdd	--	4.75	5	5.25	V
Operating Voltage for LCD	VLCD	--	--	7.3	--	V
Input Signal Voltage	Vih	--	0.7Vdd	--	Vdd	V
	Vil	--	Vss	--	0.3Vdd	V
Operating Current for LCM	Idd	Vdd=5.0V	--	1.0	--	mA



## 4. DC CHARACTERISTICS

V<sub>DD</sub>=5V ± 5%, V<sub>SS</sub>=0, T<sub>a</sub>=25

Characteristic	Symbol	Condition	Min	Typ	Max	Unit	Note
Input high voltage	V <sub>IH1</sub>	-	0.7V <sub>DD</sub>	-	V <sub>DD</sub>	V	(1)
	V <sub>IH2</sub>	-	2.0	-	V <sub>DD</sub>	V	(2)
Input low voltage	V <sub>IL1</sub>	-	0	-	0.3V <sub>DD</sub>	V	(1)
	V <sub>IL2</sub>	-	0	-	0.8	V	(2)
Output high voltage	V <sub>OH</sub>	I <sub>OH</sub> = -200μA	2.4	-	-	V	(3)
Output low voltage	V <sub>OL</sub>	I <sub>OL</sub> = 1.6mA	-	-	0.4	V	(3)
Input leakage current	I <sub>LKG</sub>	V <sub>IN</sub> = V <sub>SS</sub> - V <sub>DD</sub>	-1.0	-	1.0	μA	(4)
Three-state(off) input current	I <sub>TSL</sub>	V <sub>IN</sub> = V <sub>SS</sub> - V <sub>DD</sub>	-5.0	-	5.0	μA	(5)
Driver input leakage current	I <sub>DIL</sub>	V <sub>IN</sub> = V <sub>EE</sub> - V <sub>DD</sub>	-2.0	-	2.0	μA	(6)
Operating current	I <sub>DD1</sub>	During display	-	-	100	μA	(7)
	I <sub>DD2</sub>	During access Access cycle = 1MHz	-	-	500	μA	(7)
On resistance	R <sub>ON</sub>	V <sub>DD</sub> -V <sub>EE</sub> = 15V I <sub>LOAD</sub> = ± 0.1mA	-	-	7.5	KΩ	(8)

## 5. READ/WRITE CHARACTERISTICS

V<sub>DD</sub>=5V ± 5%, V<sub>SS</sub>=0, T<sub>a</sub>=25

Characteristic	Symbol	Min	Typ	Max	Unit
E cycle	t <sub>C</sub>	1000	-	-	ns
E high level width	t <sub>WH</sub>	450	-	-	ns
E low level width	t <sub>WL</sub>	450	-	-	ns
E rise time	t <sub>R</sub>	-	-	25	ns
E fall time	t <sub>F</sub>	-	-	25	ns
Address set-up time	t <sub>ASU</sub>	140	-	-	ns
Address hold time	t <sub>AH</sub>	10	-	-	ns
Data set-up time	t <sub>DSU</sub>	200	-	-	ns
Data delay time	t <sub>D</sub>	-	-	320	ns
Data hold time (write)	t <sub>DHW</sub>	10	-	-	ns
Data hold time (read)	t <sub>DHR</sub>	20	-	-	ns

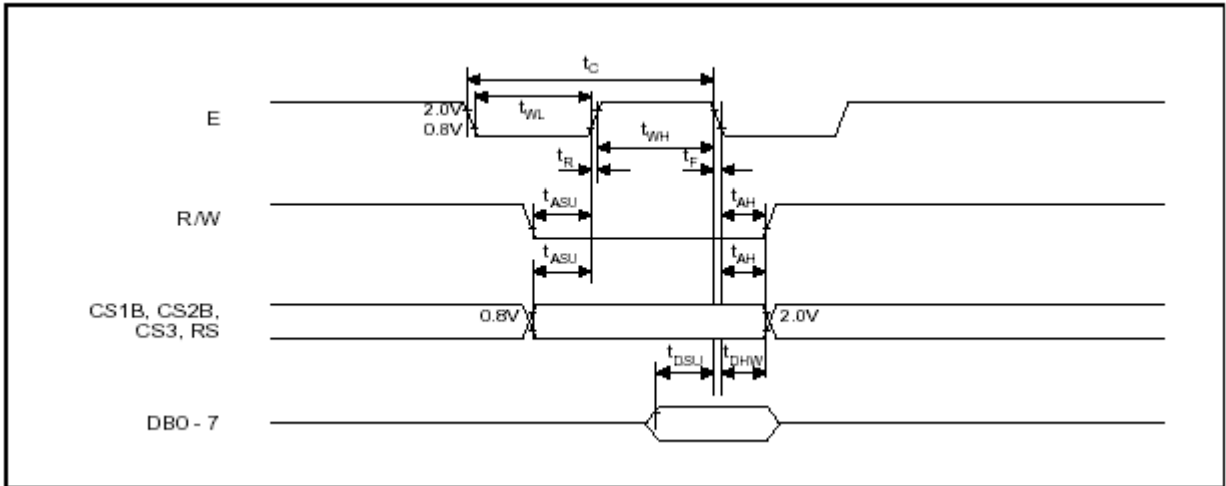

MPU Write Timing

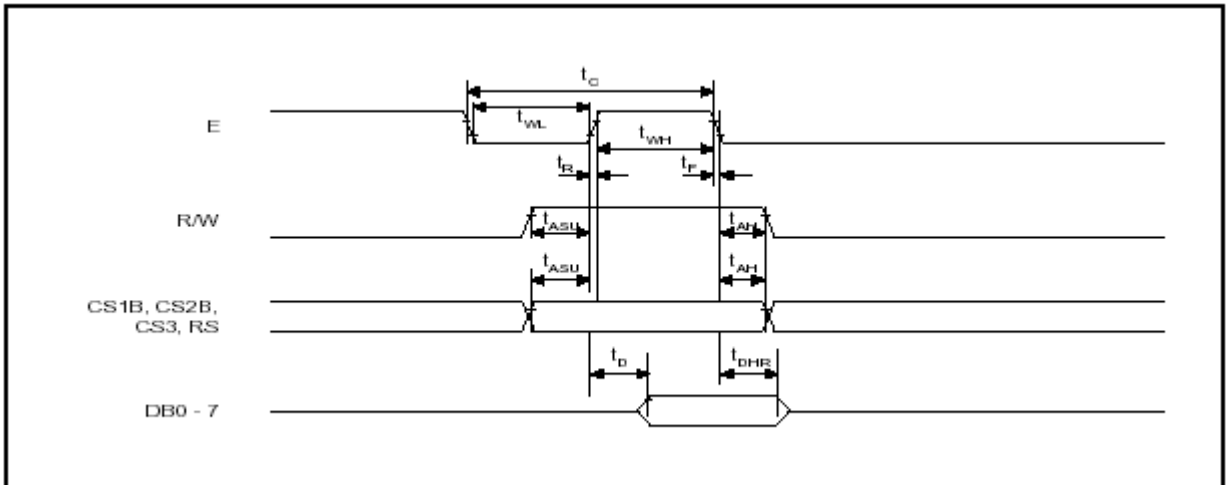

MPU Read Timing

## 6. DISPLAY CONTROL TIMING

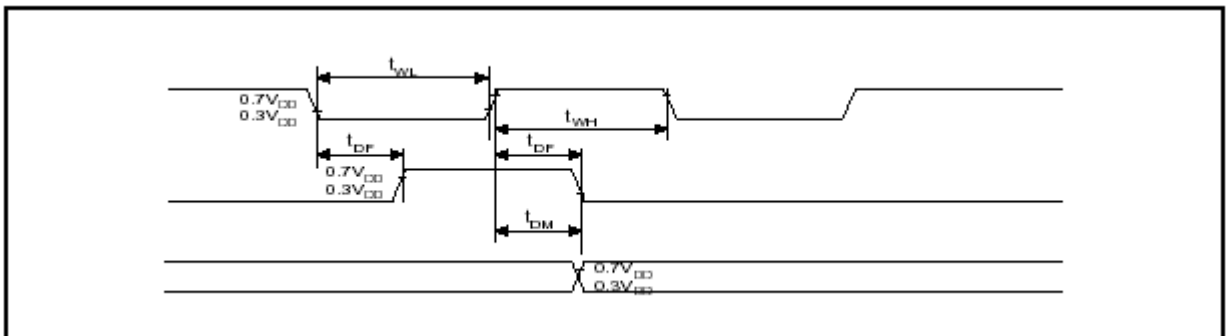



Vdd=5V ± 5%, Vss=0, Ta=25

Characteristic	Symbol	Min	Typ	Max	Unit
FRM delay time	$t_{DF}$	-2	-	+2	us
M delay time	$t_{DM}$	-2	-	+2	us
CL "low" level width	$t_{WL}$	35	-	-	us
CL "high" level width	$t_{WH}$	35	-	-	us

## 7.RESET TIMING

### RESET

The system can be initialized by setting RSTB terminal at low level when turning power on, receiving instruction from MPU.

When RSTB becomes low, following procedure is occurred.

- Display off
- Display start line register become set by 0. (Z-address 0)

While RSTB is low, No instruction except status read can be accepted. Therefore, execute other instructions after making sure that DB4 = 0 (clear RSTB) and DB7 = 0 (ready) by status read instruction. The Conditions of power supply at initial power up are shown in table 1.

Power Supply Initial Conditions

Item	Symbol	Min	Typ	Max	Unit
Reset time	$t_{RS}$	1.0	-	-	us
Rise time	$t_R$	-	-	200	ns

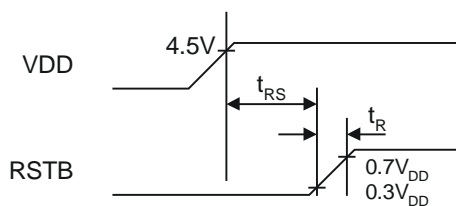



## 8. CONTROLS AND DISPLAY COMMAND

The display control instructions control the internal state of the S6B0108. Instruction is received from MPU to S6B0108 for the display control. The following table shows various instructions.

Instruction	RS	R/W	DB7	DB6	DB5	DB4	DB3	DB2	DB1	DB0	Function
Display on/off	L	L	L	L	H	H	H	H	H	L/H	Controls the display on or off. Internal status and display RAM data is not affected. L: OFF, H: ON
Set address (Y address)	L	L	L	H	Y address (0 - 63)					Sets the Y address in the Y address counter.	
Set page (X address)	L	L	H	L	H	H	H	Page (0 - 7)			Sets the X address at the X address register.
Display start line (Z address)	L	L	H	H	Display start line (0 - 63)					Indicates the display data RAM displayed at the top of the screen.	
Status read	L	H	Busy	L	On / Off	Reset	L	L	L	L	Read status. BUSY L: Ready H: In operation ON/OFF L: Display ON H: Display OFF RESET L: Normal H: Reset
Write display data	H	L	Write data								Writes data (DB0:7) into display data RAM. After writing instruction, Y address is increased by 1 automatically.
Read display data	H	H	Read data								Reads data (DB0: 7) from display data RAM to the data bus.

## 9. Power Supply

It is recommended to apply a potentiometer for the contrast adjust due to the tolerance of the driving voltage and its temperature dependence.

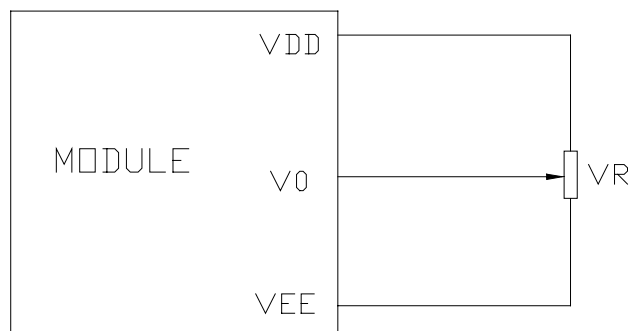



## 10. SYSTEM BLOCK DIAGRAM

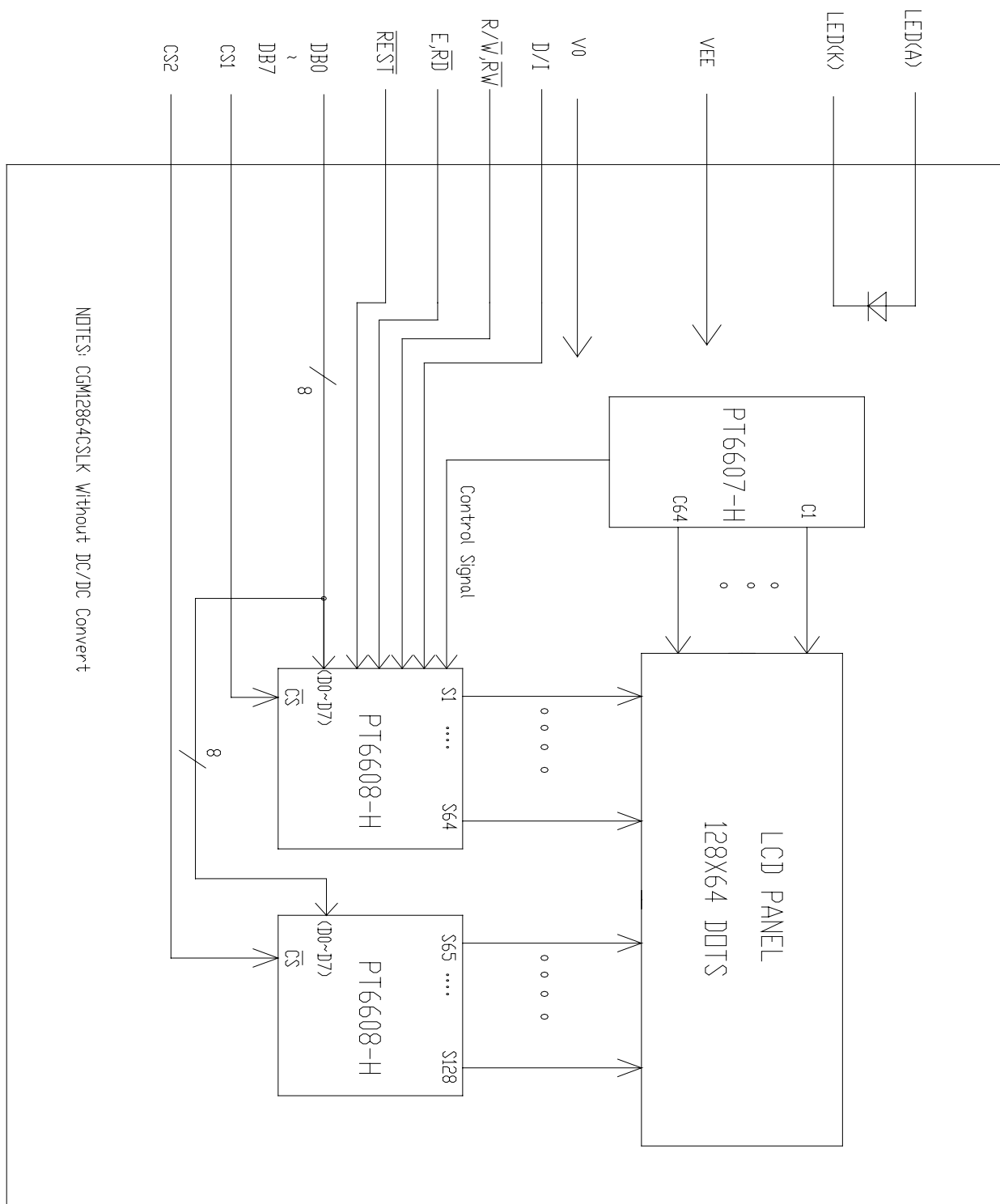



## 11. PIN ASSIGNMENT

Pin No.	Symbol	Level	Description
1	VDD	+5V	Power supply for logic and LCD (+)
2	VSS	0V	Ground
3	V0	--	Power supply voltage for LCD driving
4	DB0	H/L	Data bit0
5	DB1	H/L	Data bit1
6	DB2	H/L	Data bit2
7	DB3	H/L	Data bit3
8	DB4	H/L	Data bit4
9	DB5	H/L	Data bit5
10	DB6	H/L	Data bit6
11	DB7	H/L	Data bit7
12	CS1	L	Chip select for left panel
13	CS2	L	Chip select for right panel
14	RES	L	Reset signal
15	R/W	H/L	68 series R/W signal
16	D/I	H/L	Data type selection
17	E	H/L	68 series E clock
18	VSS	0V	Ground
19	LED (A)	--	LED +
20	LED (K)	--	LED -





## 12. ASSEMBLY DIAGRAM

PIN NO.	SIGNAL
1	Vdd
2	Vss
3	V0
4	DB0
5	DB1
6	DB2
7	DB3
8	DB4
9	DB5
10	DB6
11	DB7
12	CS1
13	CS2
14	RST
15	R/W
16	D/I
17	E
18	Vss
19	A
20	K

REMARK:

- 1.DISPLAY TYPE: STN
- 2.DISPLAY MODE: Green-Yellow
- 3.OPERATING TEMP: 0°C~50°C
- 4.STORAGE TEMP: -20°C~60°C

SCALE:15/1

<b>CASIL</b> CONHUI SEMICONDUCTOR CO.,LTD. TITLE LCM		DUTY CYCLE 1/64	PRODUCT NO. CGMI2864CSLK	REV. A SHEET OF 1/1
CHARACTERISTICS ELECTRICAL		1/9 BIASING	DWG GCMW 08.6.4	CHKD APPD
OPERATING VOLTAGE 5.0	TOLERANCE UNLESS SPECIFIED ±0.1	PROJECTION 3RD UNIT MM SCALE 1/1		
VIEWING DIRECTION	STATUS	APPD/DATE	DRWN/CHKD/APPD	FROM MODIFICATION TO
REV.	DATE			