

CGS701V Commercial/CGS701TV Industrial Low Skew PLL 1 to 8 CMOS Clock Driver

General Description

CGS701 is an off the shelf clock driver specifically designed for today's high speed designs. It provides low skew outputs which are produced at different frequencies from three fixed input references. The XTALIN input pin is designed to be driven from a 15 MHz–50 MHz crystal oscillator.

The PLL, using a charge pump and an internal loop filter, multiplies this input frequency to create a maximum output frequency of four times the input.

The device includes a TRI-STATE® control pin to disable the outputs. This feature allows for low frequency functional testing and debugging.

Also included, is an EXTSEL pin to allow testing the chip via an external source. The EXTSEL pin, once set to high, causes the External-Clock__MUX to change its input from the output of the VCO and Counter to the external clock signal provided via SKWTST input pin. (continued)

Features

- Guaranteed and tested:
 - 500 ps pin-to-pin skew (t_{OSHL} and t_{OSLH}) on 1X outputs. ± 500 ps propagation delay
- Output buffer of eight drivers for large fanout
- 25 MHz–160 MHz output frequency range
- Outputs operating at 4X, 2X, 1X of the reference frequency for multifrequency bus applications
- Selectable output frequency
- Internal loop filter to reduce noise and jitter
- Separate analog and digital V_{CC} and ground pins
- Low frequency test mode by disabling the PLL
- Implemented on National's Core CMOS process
- Symmetric output current drive: $+30/-30$ mA I_{OL}/I_{OH}
- Industrial temperature of -40°C to $+85^{\circ}\text{C}$
- 28-pin PCC for optimum skew performance
- Guaranteed 2 kV ESD protection

Connection Diagram

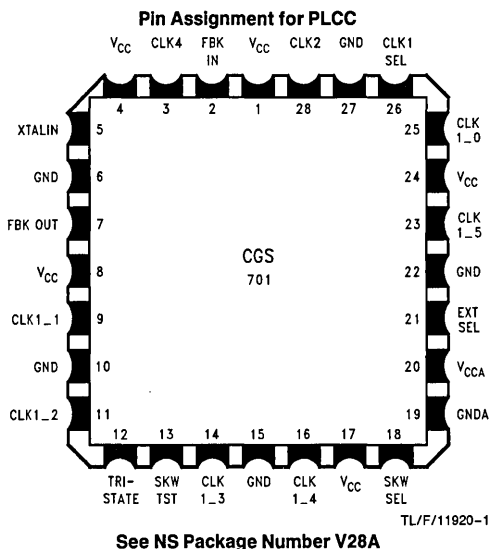

Pin Description

PLCC Package

Pin	Name	Description
1	V _{CC}	Digital V _{CC}
2	FBK IN	Feedback Input Pin
3	CLK4	4X Clock Output
4	V _{CC}	Digital V _{CC}
5	XTALIN	Crystal Oscillator Input
6	GND	Digital Ground
7	FBK OUT	Feedback Output Pin
8	V _{CC}	Digital V _{CC}
9	CLK1_1	1X Clock Output
10	GND	Digital Ground
11	CLK1_2	1X Clock Output
12	TRI-STATE	Output TRI-STATE Control
13	SKWTST	Skew Testing Pin
14	CLK1_3	1X Clock Output
15	GND	Digital Ground
16	CLK1_4	1X Clock Output
17	V _{CC}	Digital V _{CC}
18	SKWSEL	Skew Test Selector Pin
19	GND	Analog Ground
20	V _{CCA}	Analog V _{CC}
21	EXTSEL	External Clock MUX Selector
22	GND	Digital Ground
23	CLK1_5	1X Clock Output
24	V _{CC}	Digital V _{CC}
25	CLK1_0	1X Clock Output
26	CLK1SEL	CLK1 Multiplier Selector
27	GND	Digital Ground
28	CLK2	2X Clock Output

General Description (Continued)

CLK1SEL pin changes the output frequency of the CLK1_0 thru CLK1_5 outputs. During normal operation, when CLK1SEL pin is high, these outputs are at the same frequency as the input crystal oscillator, while CLK2 and CLK4 outputs are at twice and four times the input frequency respectively.

Once CLK1SEL pin is set to a low logic level, the CLK1 outputs will be at twice the input frequency, the same as the

CLK2 output, with CLK4 output still being at four times the input frequency.

In addition, another pin is added for increasing the test capability. SKWSEL pin allows testing of the counter's output and skew of the output drivers by bypassing the VCO. In this test mode CLK4 frequency is the same as SKWTST input frequency, while CLK2 is 1/2 and CLK1 frequencies are 1/4 respectively (refer to the Truth Table). In addition CLK1SEL functionality is also true under this test condition.

Block Diagram

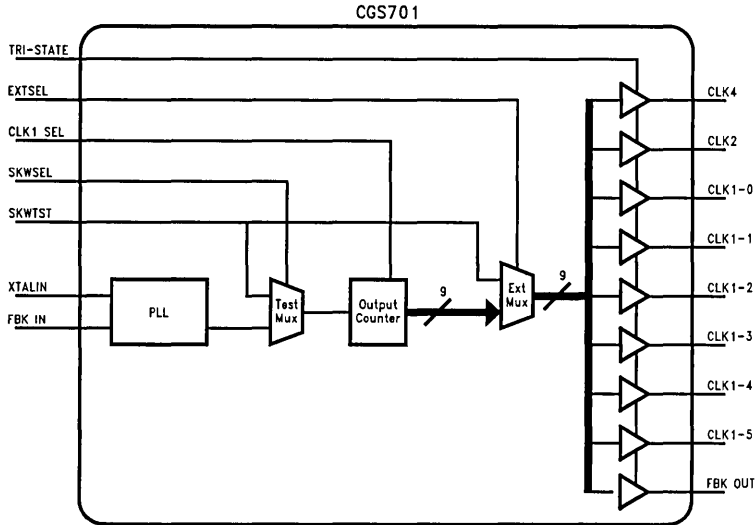

TL/F/11920-2

Truth Table

Input					Output		
CLK1 SEL	EXT SEL	SKW SEL	SKW TST	TRI-STATE	CLK4	CLK2	CLK1
H	L	L	X	H	4 x f in	2 x f in	f in
L	L	L	X	H	4 x f in	2 x f in	2 x f in
X	H	X	⌋	H	⌋	⌋	⌋
H	L	H	⌋	H	1 x f tst	1/2 x f tst	1/4 x f tst
L	L	H	⌋	H	1 x f tst	1/2 x f tst	1/2 x f tst
X	X	X	X	L	Z	Z	Z

Typical Application

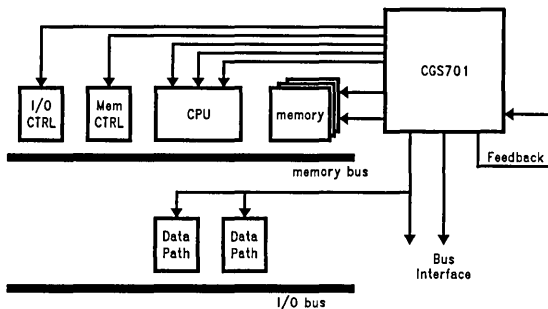

TL/F/11920-3

Absolute Maximum Ratings (Note 1)

If Military/Aerospace specified devices are required, please contact the National Semiconductor Sales Office/Distributors for availability and specifications.

Supply Voltage (V_{CC})	-0.5V to +7.0V
DC Input Voltage Diode Current (I_{IK})	
$V = -0.5V$	-20 mA
$V = V_{CC} + 0.5V$	+20 mA
DC Input Voltage (V_I)	-0.5V to $V_{CC} + 0.5V$
DC Output Diode Current (I_O)	
$V = -0.5V$	-20 mA
$V = V_{CC} + 0.5V$	+20 mA
DC Output Voltage (V_O)	-0.5V to $V_{CC} + 0.5V$
DC Output Source or Sink Current (I_O)	±60 mA
DC V_{CC} or Ground Current per Output Pin (I_{CC} or I_{GND})	±60 mA
Storage Temperature (T_{STG})	-65°C to +150°C
Junction Temperature	150°C
Power Dissipation (Static and Dynamic) (Note 2)	1400 mW

Recommended Operating Conditions

Supply Voltage (V_{CC})	4.5V to 5.5V
Input Voltage (V_I)	0V to V_{CC}
Output Voltage (V_O)	0V to V_{CC}
Input Crystal Frequency	25 MHz–40 MHz
Operating Temperature	
Commercial	0°C to +70°C
Industrial	-40°C to +85°C
External Clock Frequency (EXTCLK Pin)	1 MHz–10 MHz
Minimum Input Edge Rate ($\Delta V/\Delta t$)	
Crystal Input V_{IN} from 0.8V to 2.0V	5 ns
All Other Inputs	50 ns

Note 1: The Absolute Maximum Ratings are those values beyond which the safety of the device cannot be guaranteed. The device should not be operated at these limits. The parametric values defined in the DC and AC Electrical Characteristics tables are not guaranteed at the absolute maximum ratings. The Recommended Operating Conditions will define the conditions for actual device operation.

Note 2: Power dissipation is calculated using 49°C/W as the thermal coefficient for the PCC package at 225 LFM airflow. The input frequency is assumed at 33 MHz with CLK4 at 132 MHz and CLK2 and CLK1 being at 66 MHz. In addition, the ambient temperature is assumed 70°C.

DC Electrical Characteristics

Over recommended operating free air temperature range. All typical values are measured at $V_{CC} = 5V$, $T_A = 25^\circ C$.

Symbol	Parameter	V_{CC}	$V_{CC} = 4.5V-5.5V$ $T = 0^\circ C$ to $70^\circ C$			Units	Conditions
			Min	Typ	Max		
V_{IH}	Minimum Input High Level Voltage	4.5	2.0			V	
		5.5	2.0				
V_{IL}	Maximum Input Low Level Voltage	4.5			0.8	V	
		5.5			0.8		
V_{OH}	Minimum Output High Level Voltage	4.5	4.4	4.4		V	$I_{OUT} = -50 \mu A$ $I_{OH} = -30 mA$
		5.5	5.4	5.4			
		4.5	$V_{CC} - 0.6$				
		5.5	$V_{CC} - 0.6$				
V_{OL}	Maximum Output High Level Voltage	4.5			0.1	V	$I_{OUT} = -50 \mu A$ $I_{OL} = 30 mA$
		5.5			0.1		
		4.5			0.6		
		5.5			0.6		
I_{OH}	High Level Output Current	4.5	50	110	170	mA	$V_{OH} = V_{CC} - 1.0V$
I_{OL}	Low Level Output Current	5.5	50	110	170	mA	$V_{OL} = 1.0V$
I_{IN}	Leakage Current	4.5				μA	$V_{IN} = 0.4V$ or $4.6V$
		5.5	-50		50.0		
C_{IN}	Input Capacitance	4.5				pF	
		5.5			10.0		
I_{CC}	Quiescent Current (No Load)	5.5		0.02	0.2	mA	$V_{IN} = V_{CC}, GND$ $V_{IN} = V_{CC} - 2.1, GND$
I_{CCT}	I_{CC} per TTL Input	5.5			2.5		

AC Electrical Characteristics

Over recommended operating free air temperature range. All typical values are measured at $V_{CC} = 5V$, $T_A = 25^\circ C$.

Symbol	Parameter		Conditions	$V_{CC} = 4.5V-5.5V$ $T = 0^\circ C$ to $+70^\circ C$ $C_L =$ Circuit 1 $R_L =$ Circuit 1			Units	
				Min	Typ	Max		
t_{rise}	Output Rise	CLK4 CLK2 CLK1 All	0.8V to 2.6V 1.0V to $V_{CC} - 1.0V$ 1.0V to $V_{CC} - 1.0V$ 0.8V to 2.0V	(Note 1)			2.0 1.5	ns
t_{fall}	Output Fall	CLK4 CLK2 CLK1 All	2.6V to 0.8V $V_{CC} - 1.0V$ to 1.0V $V_{CC} - 1.0V$ to 1.0V 0.8V to 2.0V	(Note 1)			2.0 1.5	ns
t_{SKEW}	Maximum Edge-to-Edge Output Skew	+ to + Edges + to + Edges + to + Edges	CLK1 Outputs CLK1 and CLK4 CLK2 and CLK4	(Note 2)			500 500 500	ps
t_{LOCK}	Time to Lock the Output to the Synch Input						10.0	ms
t_{CYCLE}	Output Duty Cycle		CLK1 Outputs CLK2 Output CLK4 Output	(Note 3)	40 40 30		60 60 70	%
Jitter	Output Jitter			(Note 4)			0.4	ns
t_{PD}	Propogation Delay from XTALIN to FBKOUT			(Notes 6, 2, 4, 5)	-0.5		+0.5	ns

Note 1: t_{rise} and t_{fall} parameters are measured at the pin of the device.

Note 2: Skew is measured at 50% of V_{CC} .

Note 3: Output duty cycle is measured at $V_{DD}/2$.

Note 4: Jitter parameter is characterized and is guaranteed by design only. It measures the uncertainty of either the positive or the negative edge compared to its previous cycle. It is also measured at output levels of $V_{CC}/2$. Refer to *Figure 2* for further explanation.

Note 5: Measured from the ref. input to any output pin. The length of the feedback and XTALIN traces will impact this delay time.

Note 6: This parameter includes pin-to-pin skew, cycle to cycle jitter, part-to-part variation as well as propagation delay thru the device.

Note 7: The GND pins of the 701 must be as free of noise as possible for minimum jitter. Separate analog ground plane is recommended for the PCB.

Also the V_{CCA} pin requires extra filtering to further reduce noise. Ferrite beads for filtering and bypass capacitors are suggested for the V_{CCA} pin.

Circuit 1. Test Circuit

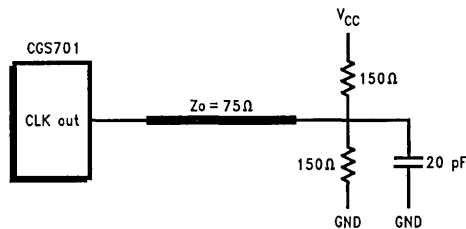

TLF/11920-4

AC Electrical Characteristics (Continued)

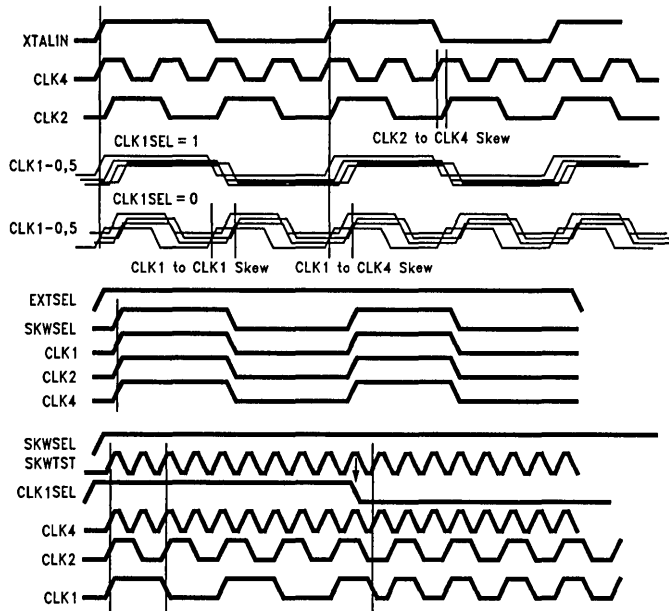
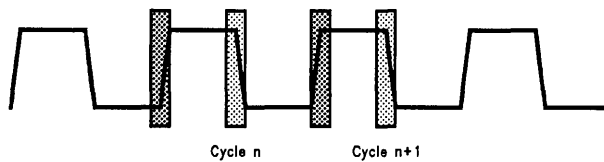

FIGURE 1. Waveforms

TL/F/11920-5



$P(n) - P(n+1) = \pm 250$ ps for either the rising or falling edge.

FIGURE 2. Jitter

TL/F/11920-6