

Universal USB-Interface-Chip CH341A

A solution for your USB project!

USB-RS232-Interface
USB-Printer-Interface
EPP/MEM Read/Write
Digital I/O
I²C-Interface

The CH341 makes it possible to interface different kind of user applications to the PC over USB, without any need of μ C controller programming. The Chip can be used as I²C interface to i²C enabled peripheral IC's. It also offers an 8 bit bi-directional data bus with EPP/MEM protocol, which could be used to interface HD44789 compatible text LCD displays for example. The Chip can also work as USB-RS232 interface, often needed to adapt AVR-applications to USB, where USB powering option is another advantage.

Programming is made easy using an API-DLL, suitable for almost any programming language (Delphi, C, VB ...). RS232 transfers can be made even easier over a virtual (USB-) COM port driver. Last but not least the CH341A is supported by our software ProfiLab Expert 4.0.

For a fast and successful approach we offer the following products around the CH341A:

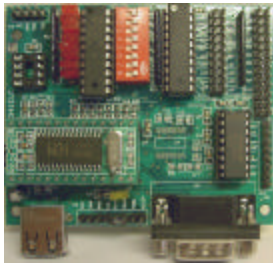

Evaluation-Board,
(DIP28 module included)

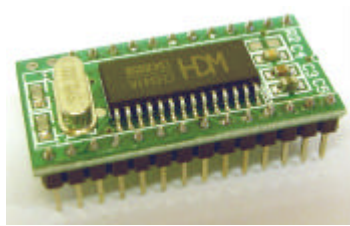

DIP28 module

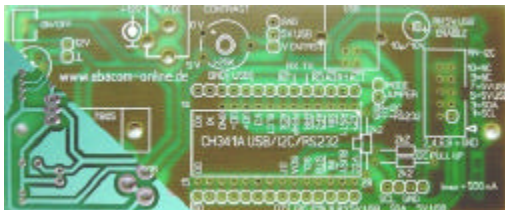

Interface PCB (DIP28-Modul included)

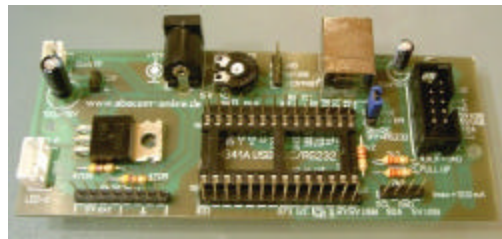

Interface Assembly Kit
(DIP28-Modul, PCB and components included)

Mode configuration

The chip is configurable for three basic modes. Depending on your circuit design the pins overtake different functional behaviour.

- **UART**
- **PRINT**
- **EPP / MEM / I²C / Digital I/O**

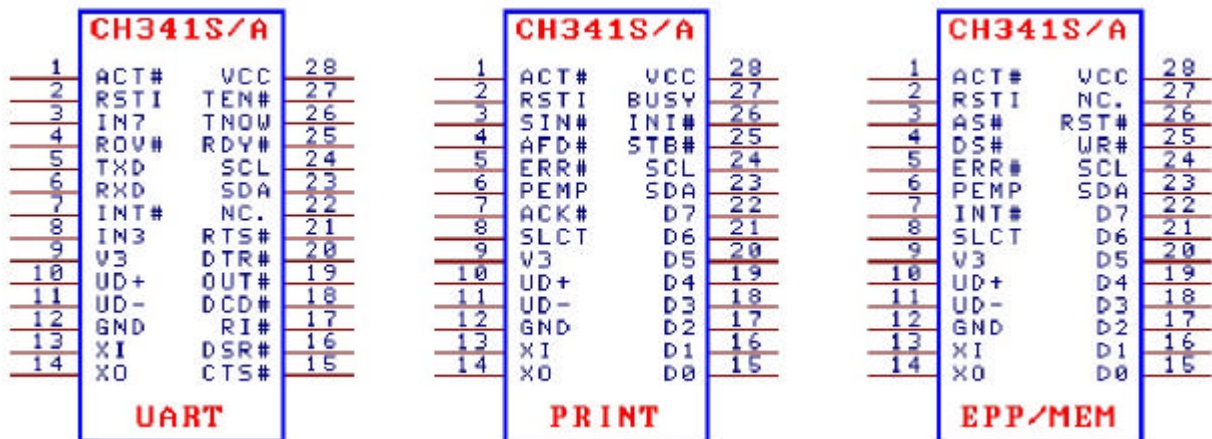

The mode configuration can be made using the pins SDA and SCL, or it can be stored in an optional serial EEPROM. Depending on the mode configuration the chip has a different USB-PID and Windows loads a certain device driver. Using an EEPROM an individual manufacturer ID and product ID can be used.

Suitable EEPROMS are 24C01A, 24C02, 24C04, 24C16, etc. During initialization the chip tries to find an EEPROM configuration first. If no such configuration is found, SDA and SCL lines determine the mode (see table below).

The EPP/MEM mode can be forced pulling the ACT# pin low to ground with a 2K resistor. The advantage is that I²C pins can still be used in that case.

SCL and SDA conditions	Mode	USB-PID
SDA and SCL open	UART; RS232	5523 hex
SDA low, SCL open	EPP/MEM/I ² C	5512 hex
SDA with SCL shortened	USB-Printer	5584 hex

USB, power supply, clock, reset

Pin	Name	Function	Remarks
28	VCC	Supply	0,1 μ F to ground
12	GND	Ground	
9	V3		3,3 V supply: connect to VCC 5 V supply: 0,01 μ F to GND
13	XI	Osc. IN	Osc. 12 MHz
14	XO	Qsc OUT	Osc 12 MHz
10	UD+	USB D+	USB line D+
11	UD-	USB D-	USB line D-
1	ACT#	Output	LOW after USB init
2	RST1	Input	External RESET input
24	SCL	I ² C	SCL bus line
23	SDA	I ² C	SDA bus line

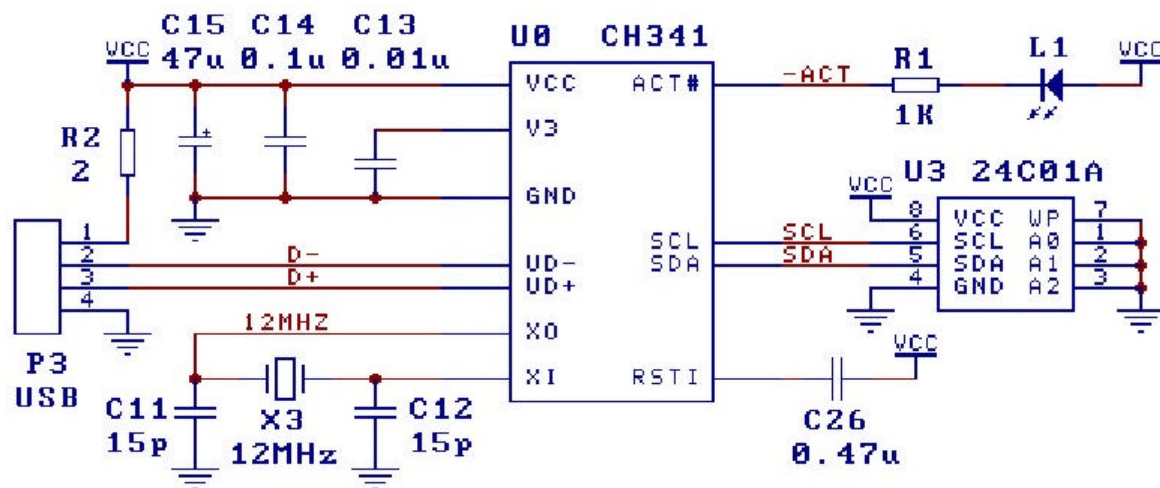

Above circuit shows how to operate the CH341A. USB connection is P3. USB cables usually use the following colour encoding:

VCC	Red
GND	Black
D+	Green
D-	White

The chip is clocked with a 12 MHz crystal. The EEPROM is optional. The circuit is USB powered. L1 indicates "Chip ready". C26 generates a power-on-reset.

UART mode

Pin	Name	Function	Remarks
5	TXD	Output	Transmit data
6	RXD	Input	Receive data
27	TEN#	Input	LOW = transmit enabled
25	RDY#	Output	LOW = ready
26	TNOW	Output	HIGH during transmission
4	ROV#	Output	LOW = Input buffer overflow
15	CTS#	Input	Hardware handshake
16	DSR#	Input	Hardware handshake
17	RI#	Input	Hardware handshake
18	DCD#	Input	Hardware handshake
20	DTR#	Output	Hardware handshake
21	RTS#	Output	Hardware handshake
19	OUT#	Output	Reserved
7	INT#	Input	Interrupt request (rising edge)
8	IN3	Input	Reserved
3	IN7	Input	Reserved
22	NC.	Reserved	Reserved

ACT#, SCL and SDA are left open to configure Chip for UART mode.

Windows installs a COM port for this configuration.

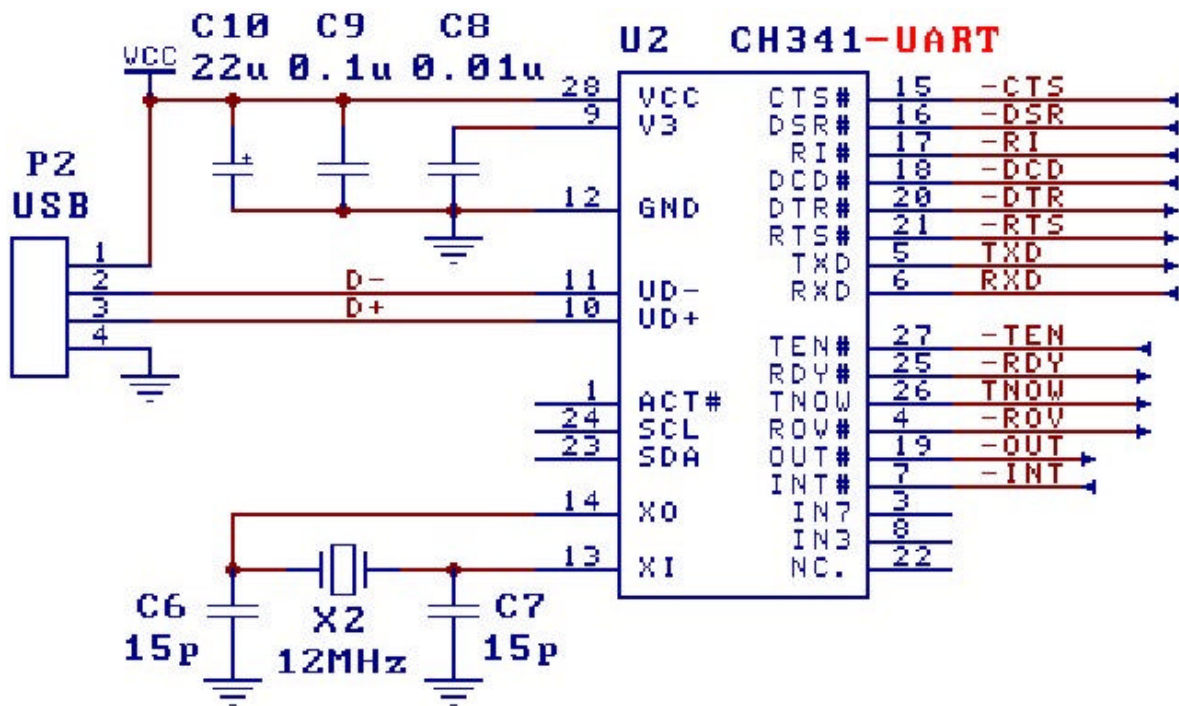

RS232 signals are available with TTL level and can be connected directly to micro-controllers (AVR, PIC,). MAX232 level converters must be used to connect the chip to other RS232 devices.

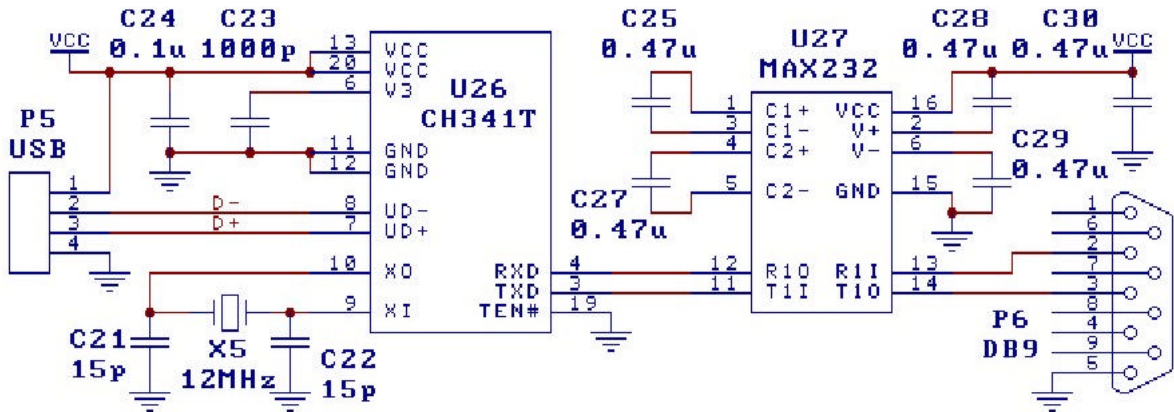

RS485 converters are easy to connect as well.

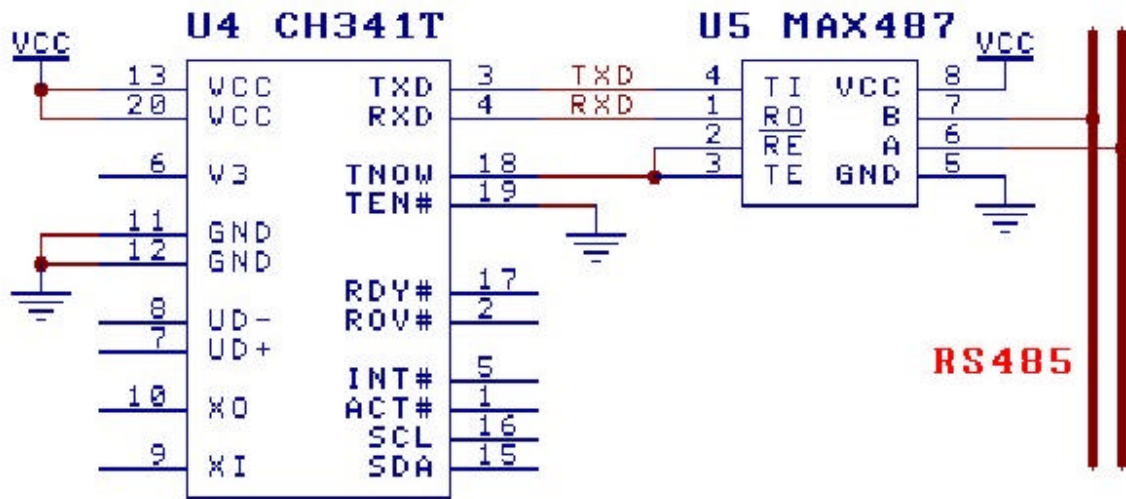

Supported COM parameters:

- Data bits: 5...9
- Stop bits: 1, 2
- Parity: none, even, odd
- Baud rates: 50, 75, 100, 110, 134.5, 150, 300, 600, 900, 1200, 1800, 2400, 3600, 4800, 9600, 14400, 19200, 28800, 33600, 38400, 56000, 57600, 76800, 115200, 128000, 153600, 230400, 460800, 921600, 1500000, 2000000.

PRINT mode

Pin	Name	Function	Remarks
22...15	D7...D0	DATA	Data lines
25	STB#	Output	Strobe
4	AFD#	Output	Auto feed
26	INI#	Output	Init
3	SIN#	Input	Select IN
5	ERR#	Input	Error
8	SLCT	Input	Select
6	PEMP	Input	Paper out
7	ACK#	Input	Acknowledge
27	BSY	Input	Busy

Shortening SCL and SDA configures chip for PRINT mode. The pins overtake functions of a standard Centronics printer port. In this mode Windows installs a "USB printer support" driver. This mode is unlikely to be used for custom applications.

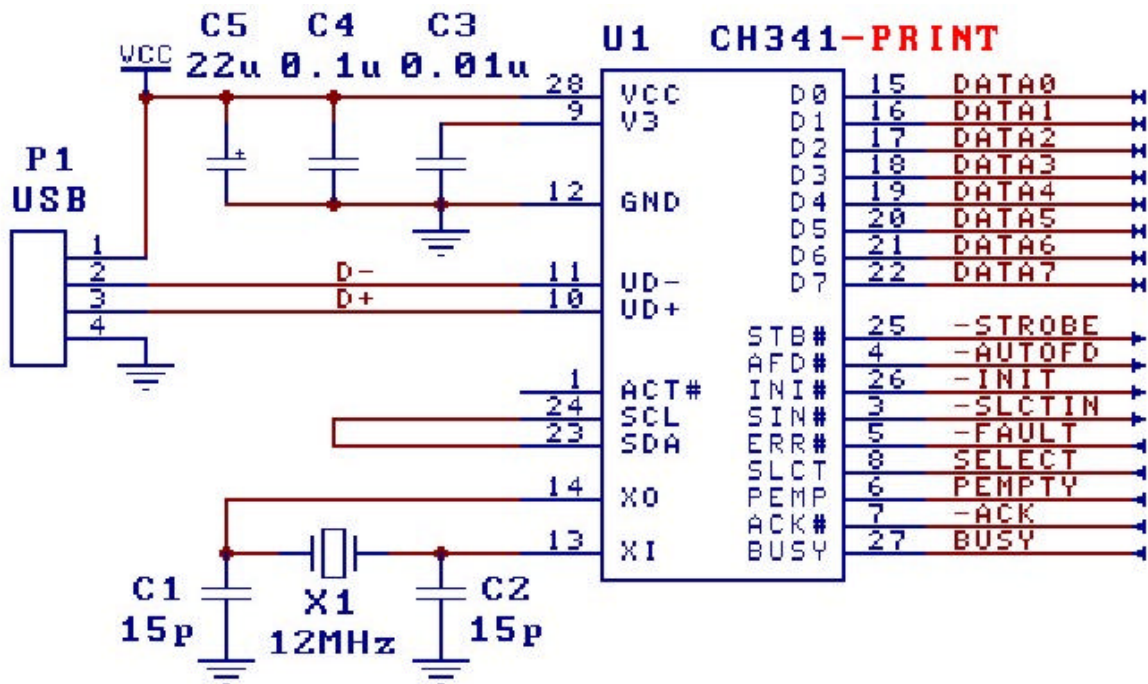

EPP / MEM / I²C / I/O

This mode can be configured in two different ways:

Pin 23 (SDA) connected to ground (=> I²C not possible)

or

Pin 1 (ACT#) connected to Ground over 2K resistor

This mode configuration will load a Windows driver that can be accessed from programming languages using an API-DLL (CH341API.DLL). Examples and include-files are available for Delphi, VB und C.

Calling an API-function the CH341A will do the data exchange with the connected peripherals itself. Depending on the called function and hardware protocol the chip will generate the necessary signal pattern at its pins. SCL (Pin 24) and SDA (Pin 23) are assigned to I²C. Other pins have different functions for EPP/MEM transfers. I/O pins can be programmed individually as well, to realize other hardware protocols by software programming.

EPP

The CH341 reads (\overline{WR} =HIGH) and writes (\overline{WR} =HIGH) from/to an 8 bit data bus. A data register (\overline{DS} =LOW) or address register (\overline{AS} =LOW) can be selected. The diagram below shows the signal pattern:

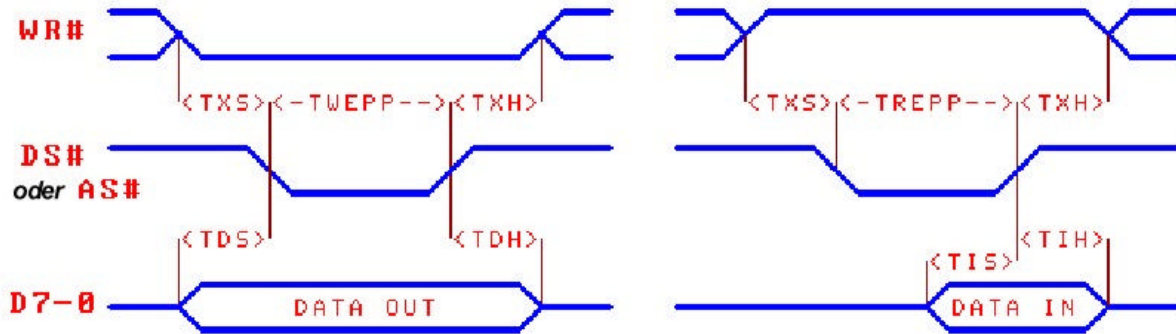

Pin	Name	Function	Remarks
22...15	D7...D0	bi-directional	8 bit data bus
25	WR#	Output	Read /Write
4	DS#	Output	/Data select
26	RST#	Output	/Reset
3	AS#	Output	/Address select
27	WAIT#	Input	/Wait
7	INT#	Input	Interrupt request (rising edge)
5	ERR#	Input	IN0
8	SLCT	Input	IN3
6	PEMP	Input	IN1

API functions:

Function CH341EppReadData(...) Read data register $\overline{WR}=1$; $\overline{DS}=0$;
 Function CH341EppReadAddr(...) Read address register $\overline{WR}=1$; $\overline{AS}=0$;
 Function CH341EppWriteData(...) Write data register $\overline{WR}=0$; $\overline{DS}=0$
 Function CH341EppWriteAddr(...) Write data register $\overline{WR}=0$; $\overline{AS}=0$
 Function CH341EppSetAddr(...) Write address register $\overline{WR}=0$; $\overline{AS}=0$ (1 Byte)

MEM

The CH341 reads (/RD=LOW) and writes (/WR=LOW) from/to an 8-bit data bus. Address line A0 allows selecting between two registers (for example reading DAC A and DAC B of a LTC7528 Dual 8-Bit DA converter or registers of HD44780 compatible LCD displays).

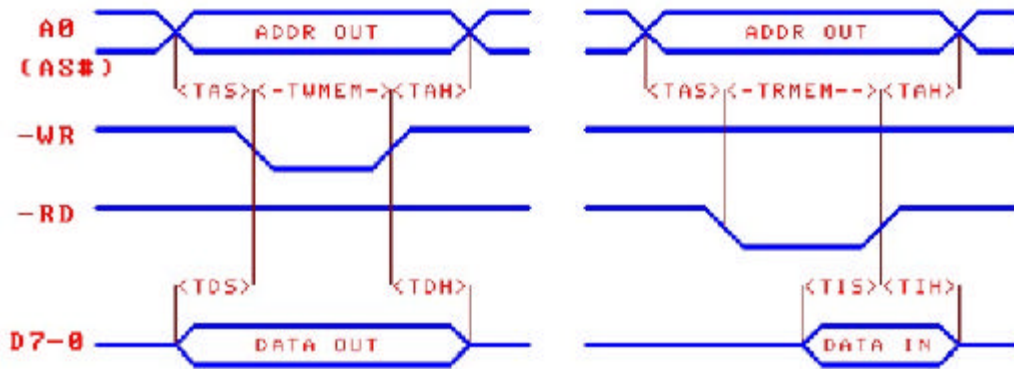

Pin	Name	Function	Remark
22...15	D7...D0	bi-directional	8-bit data bus
25	WR#	Output	/Write
4	RD#	Output	/Read
26	RST#	Output	/Reset
3	A0	Output	Address select
27	WAIT#	Input	/Wait
7	INT#	Input	Interrupt request (rising edge)
5	ERR#	Input	IN0
8	SLCT	Input	IN3
6	PEMP	Input	IN1

API functions:

- Function CH341MemReadAddr0(...) Read; A0=LOW; /RD=0
- Function CH341MemReadAddr1(...) Read; A0=HIGH /RD=0
- Function CH341MemWriteAddr0(...) Write; A0=LOW; /WR=0
- Function CH341MemWriteAddr1(...) Write; A0=HIGH; /WR=0

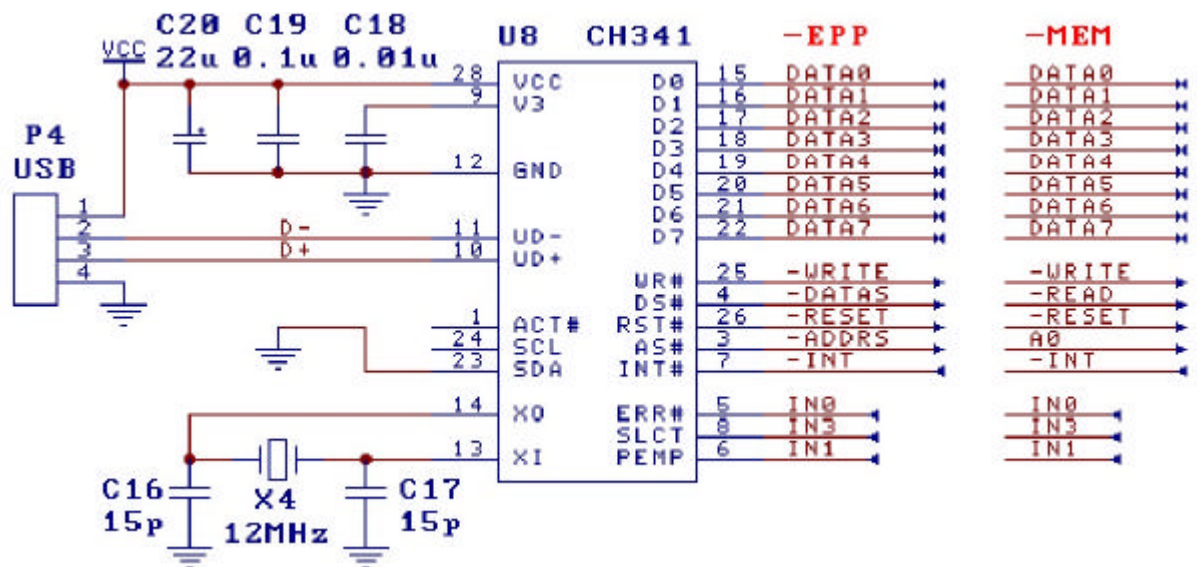

I²C (Master)

The circuit below shows I²C operation using a 24Cxx EEPROM. Additional I²C (TWI) enabled IC's can be connected to the bus lines SCL and SDA. The CH341A generates bus clock rates of 20KHz/100KHz/400KHz/750KHz and operates as bus master in any case. Slave operation is not supported.

As chip mode configuration with SDA to ground would occupy I²C lines, the chip mode must be configured with resistor R4 in this case. Pin RST# pulls down ACT# during reset, which configures chip mode. If LED L2 is not used, ACT# can be pulled low to ground with a 2K resistor as well and R3 can be removed.

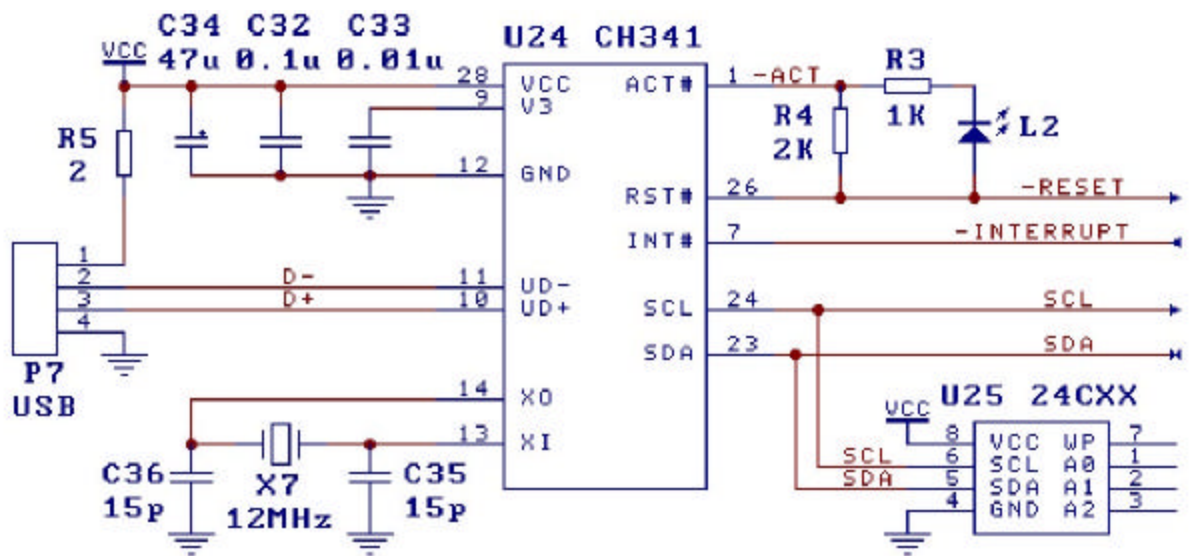

API functions

Function CH341StreamI2C(...) Read/Write I²C

Function CH341ReadI2C(...) reads from chips with internal memory or register address.

Function CH341WriteI2C(...) writes to chips with internal memory or register address.

Function CH341ReadEEPROM(...) reads I²C-EEPROM data

Function CH341WriteEEPROM(...) writes I²C-EEPROM data

SPI-Master

SPI functions are not assured for all chip versions. The description is just made to be complete.

Pin	Name	Function	Remark
22	DIN	Input	Data IN
21	DIN2	Input	Data IN2
20	DOUT	Output	Data OUT
19	DOUT2	Output	Data OUT2
18	DCK	Output	Data Clock
17	CS2	Output	CS2
16	CS1	Output	CS1
15	CS0	Output	CS0
24	SCL	Output	SCL
23	SDA	Output	SDA
26	RST#	Output	Reset
7	INT#	Input	Interrupt request (rising edge)
5,8,6		Input	Reserved

The chip operates as SPI master. Slave operation is not possible. API functions exchange data over a buffer, that needs to be filled with send data before function is called. After API function returns, the buffer contains the bytes read. This means that number of bytes read and bytes written is equal.

Standard-SPI (MODE 0)

API function: CH341StreamSPI4

Standard SPI (Mode 0) with two uni-directional data lines, clock and chip select. (Atmel, etc.)

This is the most commonly used SPI mode. Data is read from input pin 22 (DIN; DATA IN ; MISO) and written to output Pin 20 (DOUT; DATA OUT; MOSI). Pin 18 (DCK; DATA CLOCK; SCKL) offers the clock signal. Outputs CSx (Chip Select; Slave Select) activate the selected chip. Serial transfer of data may start with (MSB or LSB) first.

3-wire SPI

API function: CH341StreamSPI3

Data transfer is done with a single, bi-directional data line. A rising clock edge writes data, a falling clock edge reads data. This kind of protocol can be found at MAXIM chip DS1626 for example.

SPI with dual data lines

API function: CH341StreamSPI5

This function uses two pairs of uni-directional data lines. A data byte is split into upper and lower half. Upper nibble is transferred over DIN/DOUT, while lower nibble is transferred over DIN2/DOUT2. A concrete example for this mode could not be found.

Other serial transfers similar to SPI

API function: CH341BitStreamSPI

This function can generate an individual serial signal pattern. A LTC1257 D/A converter for example uses a 12 bit serial transfer with final LOAD signal. For such cases the function offers 6 serial output channels and 2 serial input channels. These eight channels are assigned to the bits 0..7 of the in coming and out going data bytes. Bit 6 and bit 7 contain read data from data inputs D6 and D7. Output D3 offers the clock signal. Output pattern for D0...D2, D4 and D5 is generated from the bits 0...2, 4 and 5 of the data bytes shipped to the API call. As the function does not set the data direction of the data lines, D0..D5 must be programmed as output before, using the corresponding function CH341SetOutput().

Programming I/O individually

Each I/O pin of the CH341A is assigned to a certain bit in the parameters Enable, SetDirOut and SetDataOut of the API functions listed below.

15 bi-directional pins (with programmable data direction; input or output):

Bit 0-7	D0-D7	pin 15-22
Bit 8	ERR#	pin 5
Bit 9	PEMP	pin 6
Bit 10	ACK	pin 7
Bit 11	SLCT	pin 8
Bit 12	-	-
Bit 13	BUSY/WAIT#	pin 27
Bit 14	AUTOFD#/DATAS#	pin 4
Bit 15	SLCTIN#/ADDRS#	pin 3

One pseudo-bi-directional pin (Combination of input and open-collector-output) :

Bit 23	SDA	pin 23 (functions GetInput/GetStatus)
Bit 16	SDA	pin 23 (function SetOutput)

Three uni-directional pins (output only):

Bit 16	RESET#	pin 26
Bit 17	WRITE#	pin 25
Bit 18	SCL pin	pin 24

API functions

CH341SetOutput

- Sets data direction (input/output) of bi-directional pins,
- Sets output state HIGH/LOW

CH341Set_D5_D0

- Sets data direction of pins D0...D5
- Sets output state of pins D0...D5

CH341GetInput und CH341GetStatus

- Reads input states

Parameter Enable

- Prohibits or allows changes of data direction
- Bit set = changes allowed
- Bit clear = changes are ignored

Parameter SetDirOut:

- Sets data direction: Input/Output
- Bit set = Pin operates as output (Caution!)
- Bit clear = Pin operates as input

Parameter SetDataOut

- Switch outputs
- Bit set = switch output HIGH
- Bit clear = switch output LOW

Example: CH341SetOutput(0, \$FF, \$FF, \$F0) sets data direction of D0...D7 to output. Other lines stay untouched. D0...3 are programmed LOW. D4...D7 are programmed HIGH.

Content of a optional configuration EEPROM

Byte address	Name	Remarks	Value
00 hex	SIG	53H = Signature EEPROM valid	53 hex
01 hex	MODE	23H = RS232 or 12H = EPP/MEM/PRINTER	23 hex or 12 hex
02 hex	CFG	Configuration, see next table	FE hex
03 hex		Reserved	00 hex
05...04 hex	VID	Vendor ID	4348 hex
07...06 hex	PID	Product ID	55xx hex
09...08 hex	RID	Release ID	0100 hex
17...10 hex	SN	Serial Number, eight characters	12345678
7F...20 hex	PIDS	Product name string	00 hex, 00 hex
others			00 hex or FF hex

Bit no.	Name	Remarks	Value
7	PRT	0 = USB PRINTER; otherwise 1	1
6	PWR	Power: 0 = external; 1 = USB	1
5	SN-S	Serial number 0=valid; 1=invalid	1
4	PID-S	Product string 0=valid; 1=invalid	1
3	SPD	Printer data speed 0=high; 1=low	1
2	SUSP	Suspend mode 0=prohibited; 1=permitted	1
1	PROT1		1
0	PROT0		0

API

In CH341A mode **EPP / MEM / I²C / Digital I/O** the chip can be accessed with API function calls. Therefore CH341DLL.DLL needs to be imported. Examples for Delphi, C, Visual Basic and ProfiLab Expert are available.

All API functions need to have the device number (iIndex) as first parameter. The first chip on USB is device number 0 (iIndex=0), the 2nd chip on USB is device 1, and so on.

General functions

Function CH341OpenDevice:

Function connects to CH341A and needs to be called before other calls.

Function CH341CloseDevice:

Function terminates connection with CH341A.

Function CH341ResetDevice:

Function resets chip to power-on-state.

Function CH341SetExclusive:

iExclusive:

0=shared ;

1=exclusive;

For Information on other API functions please refer to the examples

CH341A evaluation board

DIP28 module included

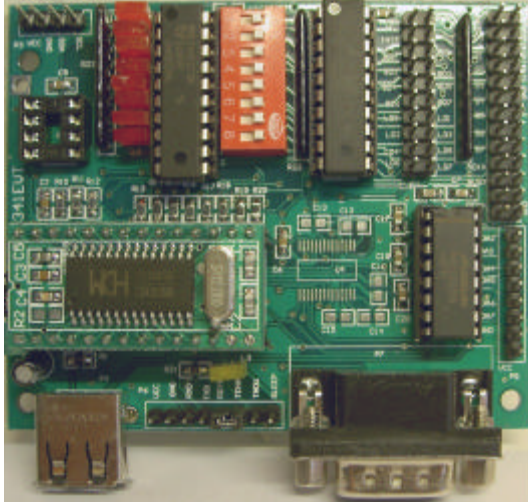

The board demonstrates the various functions of the CH341A and offers comfortable connections.

Board components

DIP28 module (included)

The CH341A chip is mounted on a breakout board with DIP28 layout. It is plugged into the evaluation board. The module is ready made with everything necessary for a basic operation: A 12MHz oscillator and some resistors and capacitors that allow connecting the module directly to the USB lines. The module can be purchased separately as well.

USB connector

The USB connections is made with an A-plug/A-plug USB cable (included).

Serial port

Connector P6 offers serial lines with TTL level. RXD and TXD signals are routed over a level converter (MAX232; U6) to a 9 pole Sub-D connector (P7). For RS232-UART operation pins TEN# and RDY# of connector P6 must be connected with a jumper. For other operation modes this jumper must be removed.

Printer port

P2 offer standard signals of a parallel printer port. The pin out is compatible with a 25 pole Sub-D printer connector. (Cables often to be found in outdated PC equipment)

Digital I/O

P1 is a 2x10 pin connector with eight digital TTL outputs (LD0..LD7) and eight digital TTL inputs (BD0..BD7), as well as GND and VCC (USB supplied voltage; Caution!). The digital inputs and outputs are realized with two TTL latches (74LS274 / 74HC245). Outputs are connected to a row of indicator LED's. Inputs can be shortened to ground by closing the contacts of an octal DIP switch (ON=input LOW). Feeding external signals to the inputs make sure that DIP switch contacts are open (OFF position!)

I²C

P3 is the I²C connector with signals SCL and SDA, as well as GND and VCC (USB supplied voltage. It allows connecting I²C peripheral IC's. U5 is prepared for an I²C EEPROM (24Cxx).

As long as no configuration EEPROM is used, the CH341A operation mode is determined with jumpers:

Jumper SDA<->SCL present between P3 (3) – P3 (4): Operation mode PRINT
Jumper removed P3 open: Operation mode UART
Jumper SDA<->GND present between P3 (3) – P3 (2): Operation mode EPP/MEM/I²C/IO

As I²C becomes occupied by jumper configuration, the operation mode EPP/MEM//I²C/IO can be configured as well connecting contacts 1 und 2 at port J1 with a jumper instead. This will connect pin1 (ACT#) und pin26 (RST#) of the CH341A with a 2K resistor.

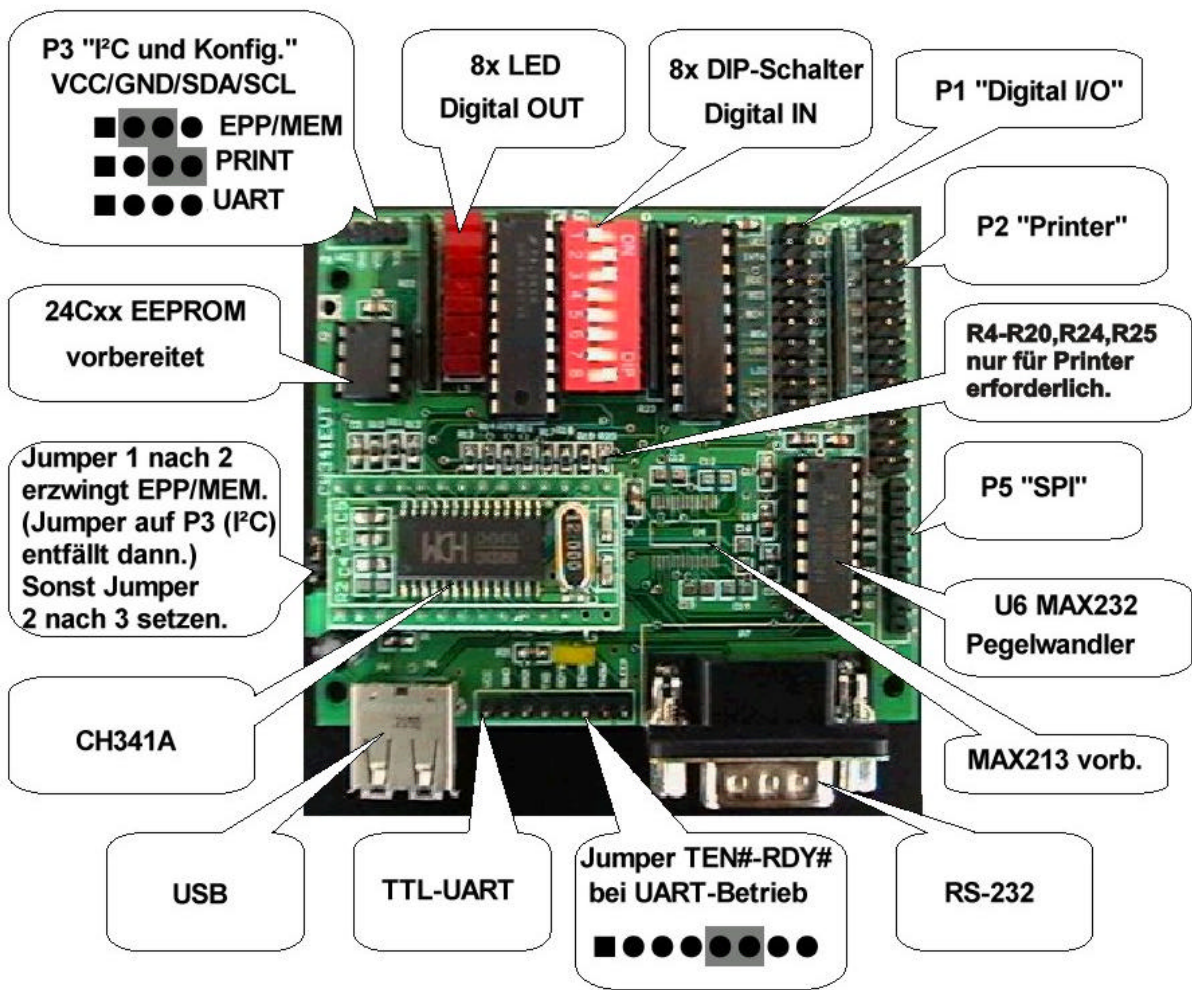

Interface PCB **DIP28 module included**

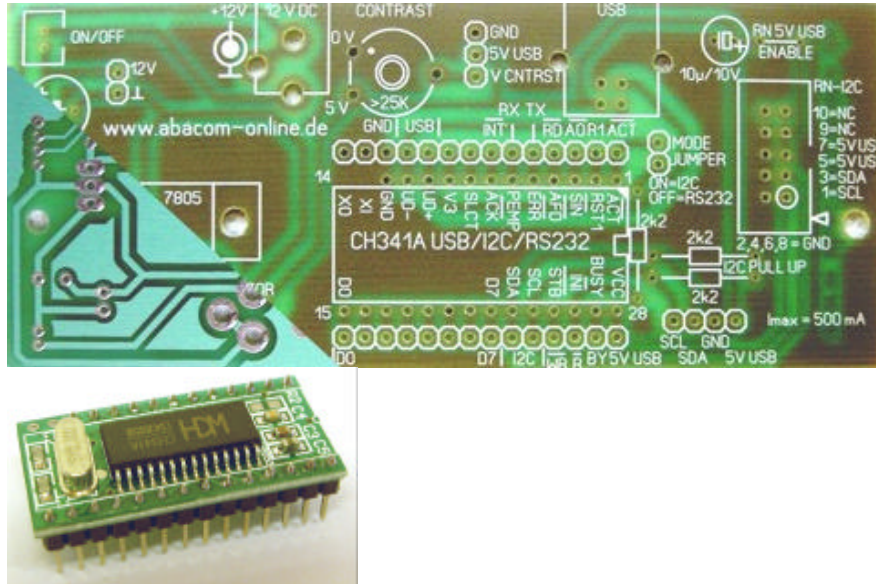

The PCB was designed to simplify your constructions based on the CH341A:

- Easy to assemble PCB
- Industrial manufactured with component print
- No SMD components
- Individual assembly options
- Fits into external 3,5"-HDD enclosure (FANTEC DB-337U2-B)
- Dimensions ca. 110 x 45 mm

Minimum assembly for USB->RS232 (TTL)

All you need to do is to solder in the DIP module, the USB jack and a wire between /WR (Pin 25) and BY (Pin 27). Connect RX and TX (TTL level!) to you application.

Minimum assembly for USB->I2C

A 2K2 resistor and the MODE jumper (or wire) must be added must be added. The connection Pin25 – Pin27 must be removed in this case.

Assembly options

- It is recommended using a low-cost IC socket for the DIP module.
- Pin connector with Jumper for mode selection RS232/I2C
- Pull-up resistors (2x2K2) for I2C bus lines SDA and SCL, if not provided by elsewhere.
- 4 pin I2C connector (5V-USB, USB-Masse, SDA, SCL), if not wired directly.
- 10 pole I2C connector, following rules on http://www.roboternetz.de/wissen/index.php/RN-Definitionen#I2C-Bus_Stecker .
- All CH341A pin routed to pin connectors, if not wired directly.
- Potentiometer (VCONSTRAST = 0...5V USB) useful as LCD contrast voltage, trigger level, etc. Make sure value is 25K minimum!
- Voltage regulator for external power supply (for user circuit). The external supply voltage is separated from the USB ground.
- LED-R / LED-G are provided for two indicator LED's for USB and external voltage. Add 2x 470R resistors for that option.

Interface PCB DIP28 module, PCB and Components included

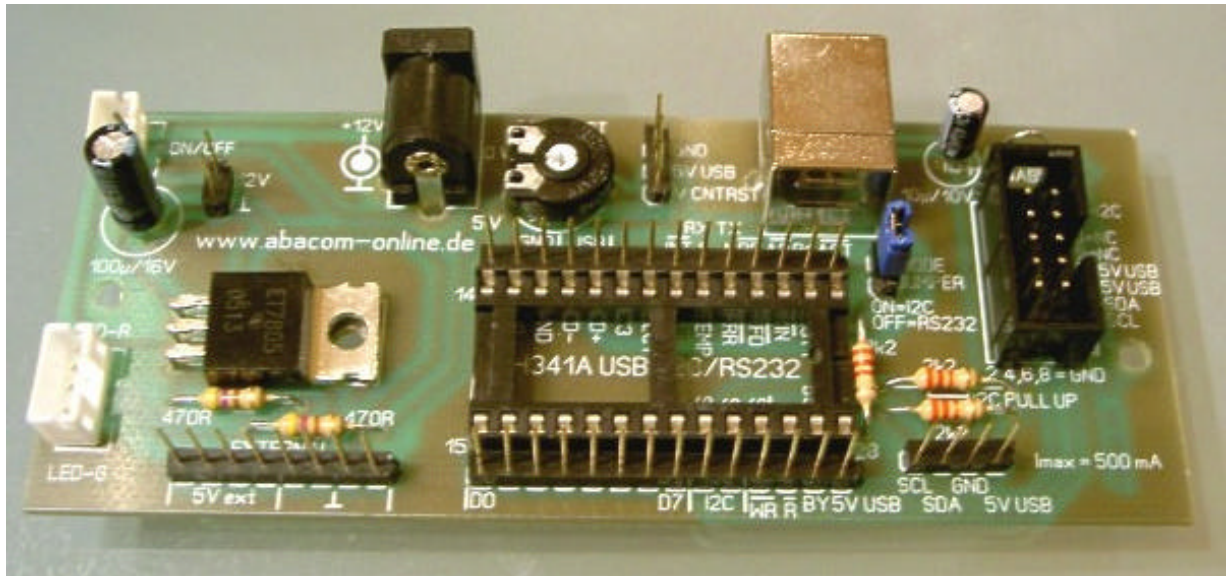

Enclosure (not included)

The PCB fits exactly into an external 3,5" HDD enclosure ([FANTEC DB-337U2-B](#)). The enclosure is available from many PC component distributors for less than 25 Euro. The enclosure is delivered with a powerful external 12V/2A power supply. The enclosure is big enough for a 100x160 cm PCB together with our interface PCB. The two half-shells snap together without screws, allowing wall-mounting as well as desktop applications.



Remove the controller PCB from the enclosure and keep screws for re-use. The enclosure has a built in switch and two indicator LED's. Their connectors fit into our interface board. Mount the interface board. DC jack and USB jack fit as well.

The enclosure has a printed "Mobile Disk" label. You may want to remove this, but be careful. We had best results using a razor blade as spatula to scrape off the paint. Finally polish with a pot sponge. With our sample this worked best and without damage. Chemicals strongly not recommended!

Appendix: API functions (CH341DLL.DLL)

```
// *****
// USB functions
// *****
type    mPCH341_NOTIFY_ROUTINE =ProceDure (iEventStatus:cardinal); stdcall;
const  CH341_DEVICE_ARRIVAL =      3 ;
        CH341_DEVICE_REMOVE_PEND =  1 ;
        CH341_DEVICE_REMOVE      =  0 ;
Function CH341SetDeviceNotify(iIndex:cardinal; iDeviceID: PCHAR;
iNotifyRoutine:mPCH341_NOTIFY_ROUTINE):boolean;Stdcall; external 'CH341DLL.DLL';

// *****
// General routines
// *****

// CH341A is addressed with 'iIndex':
// iIndex=0 => 1st CH341 @ USB
// iIndex=1 => 2nd CH341 @ USB
// iIndex=2 => 3rd ...

// CH341OpenDevice: Connect to CH341A
Function CH341OpenDevice(iIndex: cardinal); Stdcall; external 'CH341DLL.DLL' ;
// CH341CloseDevice: Terminate connection with CH341A
procedure CH341CloseDevice(iIndex: cardinal); Stdcall; external 'CH341DLL.DLL';
// CH341ResetDevice: CH341A reset to power-on defaults
Function CH341ResetDevice(iIndex: cardinal): boolean; Stdcall; external 'CH341DLL.DLL';
// CH341SetExclusive: //Allow/prevent re-open
// iExclusive: 0=shared ;
//              1=exclusive;
Function CH341SetExclusive(iIndex:cardinal; iExclusive:cardinal ):boolean;Stdcall; external
'CH341DLL.DLL';

// *****
// Information requests
// *****
Function CH341GetVersion: cardinal; Stdcall; external 'CH341DLL.DLL';
Function CH341DriverCommand(iIndex: cardinal; ioCommand: mPWIN32_COMMAND):cardinal; Stdcall;
external 'CH341DLL.DLL';
Function CH341GetDrvVersion: cardinal; Stdcall; external 'CH341DLL.DLL';
Function CH341GetDeviceDescr(iIndex: cardinal; oBuffer: PVOID; ioLength: PULONG): boolean;
Stdcall; external 'CH341DLL.DLL';
Function CH341GetConfigDescr(iIndex: cardinal; oBuffer: PVOID; ioLength: PULONG): boolean;
Stdcall; external 'CH341DLL.DLL';
Function CH341GetDeviceName(iIndex:cardinal):PVOID;Stdcall; external 'CH341DLL.DLL';
Function CH341GetVerIC(iIndex:cardinal):cardinal;Stdcall; external 'CH341DLL.DLL';

// *****
// Interrupts
// *****
Function CH341SetIntRoutine(iIndex: cardinal; iIntRoutine: mPCH341_INT_ROUTINE): boolean;Stdcall;
external 'CH341DLL.DLL';
Function CH341ReadInter(iIndex: cardinal; iStatus:PULONG): boolean; Stdcall; external
'CH341DLL.DLL';
Function CH341AbortInter(iIndex: cardinal): boolean; Stdcall; external 'CH341DLL.DLL';

// Buffer (USB?) RS-232?
Function CH341SetBufUpload(iIndex:cardinal; iEnableOrClear:cardinal ):boolean;Stdcall; external
'CH341DLL.DLL';
Function CH341QueryBufUpload(iIndex:cardinal):integer;Stdcall; external 'CH341DLL.DLL';
Function CH341SetBufDownload(iIndex:cardinal; iEnableOrClear:cardinal ):boolean;Stdcall; external
'CH341DLL.DLL';
Function CH341QueryBufDownload(iIndex:cardinal ):integer;Stdcall; external 'CH341DLL.DLL';

// (USB?) RS-232?
Function CH341ResetInter(iIndex:cardinal ):boolean;Stdcall; external 'CH341DLL.DLL';
Function CH341ResetRead(iIndex:cardinal ):boolean;Stdcall; external 'CH341DLL.DLL';
Function CH341ResetWrite(iIndex:cardinal ):boolean;Stdcall; external 'CH341DLL.DLL';

// USB ? RS-232?
//Delay; iDelay: Unit lms
Function CH341SetDelaymS(iIndex:cardinal; iDelay:cardinal ):boolean;Stdcall; external
'CH341DLL.DLL';
//Timeout; iWriteTimeout: Unit lms
```

```

Function CH341SetTimeout(iIndex:cardinal; iWriteTimeout:cardinal; iReadTimeout:cardinal
):boolean;Stdcall; external 'CH341DLL.DLL';
Function CH341ReadData(iIndex:cardinal; oBuffer:PVOID; ioLength:PULONG ):boolean;Stdcall;
external 'CH341DLL.DLL';
Function CH341WriteData(iIndex:cardinal; iBuffer:PVOID; ioLength:PULONG ):boolean;Stdcall;
external 'CH341DLL.DLL';
Function CH341FlushBuffer(iIndex:cardinal):boolean;Stdcall; external 'CH341DLL.DLL';
Function CH341WriteRead(iIndex:cardinal; iWriteLength:cardinal; iWriteBuffer:PVOID;
iReadStep:cardinal; iReadTimes:cardinal; oReadLength:PULONG; oReadBuffer:PVOID
):boolean;Stdcall; external 'CH341DLL.DLL' ;

// *****
// Parallel data transfer (EPP/MEM)
// *****
// iMode: 0 = EPP/EPP V1.7 ; 1 = EPP V1.9, 2 = MEM; 256 = keep current
Function CH341InitParallel(iIndex: cardinal; iMode :cardinal): boolean; Stdcall; external
'CH341DLL.DLL';
// iMode: 0 = EPP/EPP V1.7 ; 1 = EPP V1.9, 2 = MEM
Function CH341SetParaMode(iIndex: cardinal; iMode: cardinal): boolean; Stdcall; external
'CH341DLL.DLL';
// Read & Write (MEM und EPP)
Function CH341ReadData0(iIndex: cardinal; oBuffer: PVOID; ioLength: PULONG ): boolean; Stdcall;
external 'CH341DLL.DLL';
Function CH341ReadData1(iIndex: cardinal; oBuffer: PVOID; ioLength: PULONG ): boolean; Stdcall;
external 'CH341DLL.DLL';
Function CH341AbortRead(iIndex: cardinal): boolean; Stdcall; external 'CH341DLL.DLL';
Function CH341WriteData0(iIndex:cardinal; iBuffer: PVOID; ioLength: PULONG ): boolean; Stdcall;
external 'CH341DLL.DLL';
Function CH341WriteData1(iIndex:cardinal; iBuffer: PVOID; ioLength: PULONG ): boolean; Stdcall;
external 'CH341DLL.DLL';
Function CH341AbortWrite(iIndex:cardinal): boolean; Stdcall; external 'CH341DLL.DLL';

// EPP Read/Write
Function CH341EppReadData(iIndex:cardinal; oBuffer:PVOID; ioLength:PULONG ):boolean; Stdcall;
external 'CH341DLL.DLL';
Function CH341EppReadAddr(iIndex:cardinal; oBuffer:pvoid; ioLength:PULONG ):boolean;Stdcall;
external 'CH341DLL.DLL';
Function CH341EppWriteData(iIndex:cardinal; iBuffer:pvoid; ioLength:PULONG ):boolean;Stdcall;
external 'CH341DLL.DLL';
Function CH341EppWriteAddr(iIndex:cardinal; iBuffer:PVOID; ioLength:PULONG ):boolean;Stdcall;
external 'CH341DLL.DLL';
Function CH341EppSetAddr(iIndex:cardinal; iAddr:byte ):boolean;Stdcall; external 'CH341DLL.DLL';

// MEM Read/Write
Function CH341MemReadAddr0(iIndex:cardinal; oBuffer:pvoid; ioLength:PULONG ):boolean;Stdcall;
external 'CH341DLL.DLL';
Function CH341MemReadAddr1(iIndex:cardinal; oBuffer:pvoid; ioLength:PULONG ):boolean;Stdcall;
external 'CH341DLL.DLL';
Function CH341MemWriteAddr0(iIndex:cardinal; iBuffer:pvoid; ioLength:PULONG ):boolean;Stdcall;
external 'CH341DLL.DLL';
Function CH341MemWriteAddr1(iIndex:cardinal; iBuffer:pvoid; ioLength:PULONG ):boolean;Stdcall;
external 'CH341DLL.DLL';

// *****
// Serial data transfer (I2C, RS232, SPI)
// *****

// CH341SetStream() konfiguriert I2C und SPI
// Bit 1-0: I2C speed 00= low speed /20KHz
//          01= standard /100KHz
//          10= fast /400KHz
//          11= high speed /750KHz

// Bit 2: SPI - Modus
//          0= Standard SPI (D3=clock out, D5=serial out, D7 serial in
//          1= SPI with two data lines (D3=clock out, D5,D4=serialout, D7,D6 serial
in)

// Bit 7: SPI          0= LSB first
//                   1= MSB first

// other bits          0 (reserved)
Function CH341SetStream(iIndex:cardinal; iMode:cardinal):boolean;Stdcall; external
'CH341DLL.DLL';

// *****
// SPI - Serial Peripheral Interface
// *****
//

```



```

// CH341A is MASTER in any case
//
// CH341BitStreamSPI()
// Serial daten transfer with (non-SPI conform) IC's (e.g. LTC1257)
// Simultaneously READ and WRITE through ioBuffer byte array:

// Bit7: D7 <- Input (read data)
// Bit6: D6 <- Input (read data)
// Bit5: D5 -> Output (write data)
// Bit4: D4 -> Output (write data)
// Bit3: D3 -> Output (SCLK; serial clock generated by CH341A);
// Bit2: D2 -> Output (write data)
// Bit1: D1 -> Output (write data)
// Bit0: D0 -> Output (write data)

// Output pattern is defined by bits D0,D1,D2,D4,D5 of bytes in ioBuffer (before function call).
// Bits D6 and D7 of bytes in ioBuffer contain read data (after function call).
// D3 is the auto-generated clock signal. (positive pulse for each byte in ioBuffer)
// Call Set_D5_D0(iIndex, $3F) before to set D0...D5 direction to output!
// iLength is the number of bytes to be transfered through ioBuffer.
Function CH341BitStreamSPI(iIndex:cardinal; iLength:cardinal; ioBuffer:PVOID):boolean;Stdcall;
external 'CH341DLL.DLL';

// CH341StreamSPI4()
// Standard SPI (Mode 0) with two uni-directional data lines, clock and chip select.
//
// D7 <- Input (Read data; MISO)
// D5 -> Output (Write data; MOSI)
// D3 -> Output (SCLK; serial clock generated by CH341A);
// D2 -> Output (Chip Select 2)
// D1 -> Output (Chip Select 1)
// D0 -> Output (Chip Select 0)
Function CH341StreamSPI4(iIndex:cardinal; iChipSelect:cardinal; iLength:cardinal; ioBuffer:PVOID
):boolean;Stdcall; external 'CH341DLL.DLL';

// CH341StreamSPI3()
// SPI with only ONE bi-directional(!) data line, clock and chip select
// e.g. Maxim (DS1626); (Write with rising clock; read with falling clock)
Function CH341StreamSPI3(iIndex:cardinal; iChipSelect:cardinal; iLength:cardinal;
ioBuffer:PVOID):boolean;Stdcall; external 'CH341DLL.DLL';

// CH341StreamSPI5()
// SPI with 4 data lines (2 pairs uni-directional);
Function CH341StreamSPI5(iIndex:cardinal; iChipSelect:cardinal; iLength:cardinal; ioBuffer:PVOID;
ioBuffer2:PVOID ):boolean;Stdcall; external 'CH341DLL.DLL';

// *****
// *** I2C ***
// *****
//
// CH341A is MASTER in any case
//
// CH341StreamI2C(): Universal READ and/or WRITE over I2C
// READ only: iWriteLength = 0;
// WRITE only: iReadLength = 0;
Function CH341StreamI2C(iIndex:cardinal; iWriteLength:cardinal; iWriteBuffer:pvoid;
iReadLength:cardinal; oReadBuffer:pvoid ):boolean;stdcall; external 'CH341DLL.DLL';

// READ and WRITE from/to IC with internal register-/memory address
// iDevice: 0..127 = I2C device address
// iAddr: register address; This is not the I2C device address!
Function CH341ReadI2C(iIndex:cardinal; iDevice: byte; iAddr: byte; oByte: pbyte ):boolean;
Stdcall; external 'CH341DLL.DLL';
Function CH341WriteI2C(iIndex:cardinal; iDevice :byte; iAddr: byte; iByte: byte ):boolean;
Stdcall; external 'CH341DLL.DLL';
// I2C-EEPROM: READ and WRITE
type EEPROM_TYPE
=(ID_24C01, ID_24C02, ID_24C04, ID_24C08, ID_24C16, ID_24C32, ID_24C64, ID_24C128, ID_24C256, ID_24C512, ID
_24C1024, ID_24C2048, ID_24C4096);
Function CH341ReadEEPROM(iIndex:cardinal; iEepromID:EEPROM_TYPE; iAddr:cardinal;
iLength:cardinal; oBuffer:Pbytearray ):boolean;stdcall; external 'CH341DLL.DLL';
Function CH341WriteEEPROM(iIndex:cardinal; iEepromID:EEPROM_TYPE; iAddr:cardinal;
iLength:cardinal; iBuffer:pbytearray ):boolean;stdcall; external 'CH341DLL.DLL';

// *****
// Direct I/O pins programming
// *****

```

```

// iEnable:      Enable data direction changes
//              Bit set = allow changes
//              Bit clear = prevent changes
// iSetDirOut:   Data direction setting: Input or Output
//              Bit set = Pin programmed as output (Caution!)
//              Bit clear = Pin is input
// iSetDataOut:  Output status
//              Bit set = Output HIGH
//              Bit clear = Output LOW

// Pin assignment CH341A:

// Bi-directional pins (input or output):
// Bit 0-7 = D0-D7          pin 15-22
// Bit 8 = ERR#            pin 5
// Bit 9 = PEMP            pin 6
// Bit 10 = ACK            pin 7
// Bit 11 = SLCT           pin 8
// Bit 12 = unused         -
// Bit 13 = BUSY/WAIT#     pin 27
// Bit 14 = AUTOFD#/DATAS# pin 4
// Bit 15 = SLCTIN#/ADDRS# pin 3

// pseudo-bi-directional pins (Combination of input and open-collector output) :
// Bit 23 = SDA            pin 23 (for functions GetInput/GetStatus)
// Bit 16 = SDA            pin 23 (for funktion SetOutput)

// Uni-directional pins (output only):
// Bit 16 = RESET#         pin 26
// Bit 17 = WRITE#         pin 25
// Bit 18 = SCL pin        pin 24

// Note: Other API functions (e.g. RS232, SPI, ... may change pins!
// Connections between two outputs can cause damage to the chip.

// Set outputs
Function CH341SetOutput(iIndex:cardinal; iEnable:cardinal;
iSetDirOut:cardinal;iSetDataOut:cardinal ):boolean;Stdcall; external 'CH341DLL.DLL';
Function CH341Set_D5_D0(iIndex:cardinal; iSetDirOut:cardinal; iSetDataOut:cardinal
):boolean;Stdcall; external 'CH341DLL.DLL';
// read inputs
Function CH341GetInput(iIndex:cardinal; iStatus:PULONG ):boolean;Stdcall; external
'CH341DLL.DLL';
Function CH341GetStatus(iIndex:cardinal; iStatus: PULONG ): boolean; Stdcall; external
'CH341DLL.DLL';

// *****
// RS-232
// *****

// iParityMode:
// 0 = NONE
// 1 = ODD
// 2 = EVEN
// 3 = MARK
// 4 = SPACE
// iBaudRate:
// 50, 75, 100, 110, 134.5, 150, 300, 600, 900, 1200, 1800, 2400, 3600, 4800,
// 9600, 14400, 19200, 28800, 33600, 38400, 56000, 57600, 76800, 115200, 128000,
// 153600, 230400, 460800, 921600, 1500000, 2000000
Function CH341SetupSerial(iIndex:cardinal; iParityMode:cardinal; iBaudRate:cardinal
):boolean;Stdcall; external 'CH341DLL.DLL';

```