CH7105B HDMI to SDTV/VGA Converter

FEATURES

- HDMI Receiver compliant with HDMI 1.4 specifications
- Support multiple output formats:
 - SDTV format (CVBS or S-Video output, NTSC and PAL)
 - Analog RGB output for VGA with Triple 9-bit DAC up to 200MHz pixel rate. Sync signals can be provided in separated or composite manner. Support VESA and CEA timing standards up to UXGA and 1920x1080@60Hz
- On-chip Audio encoder which support 2 channel IIS/S/PDIF audio output
- VGA output is compliant with VESA VSIS v1r2 specification
- MCU embedded to handle the control logic
- Support device boot up by automatically loading firmware from on-chip flash
- Integrated EDID Buffer
- TV/VGA connection detection supported
- HDMI input detection supported
- Scaler engine integrated for 640x480 safe mode input supported in SDTV output application
- Support Auto Power Saving mode and low stand-by current
- Support RGB to YCC conversion in ITU-R BT.601 and 709 color space
- IIC slave interface and HDMI DDC interface are available for debug and firmware update.
- Low power architecture
- RoHS compliant and Halogen free package
- Offered in 40-Pin QFN package (5 x 5 mm)

APPLICATION

- Car Infotainment Device
- HDMI to VGA/SDTV Adapter/Docking Station
- Notebook/Ultrabook
- IPC
- Handheld/Portable Device
- Digital Video Systems

GENERAL DESCRIPTION

Chrontel's CH7105B is a low-cost, low-power semiconductor device that consists of HDMI receiver, three separate 9-bit video Digital-to-Analog Converters (DACs), SDTV encoder and audio encoder, which can convert HDMI signals into CVBS/S-Video/VGA outputs with IIS or SPDIF audio output.

The HDMI Receiver integrated is compliant with HDMI 1.4b. With sophisticated MCU and the on-chip flash, CH7105B supports auto-boot and EDID buffer. Take the advantage of Firmware auto loaded from the embedded flash, CH7105B can support HDMI input detection, DAC connection detection and determine to enter into SDTV mode or VGA mode or Power saving mode automatically.

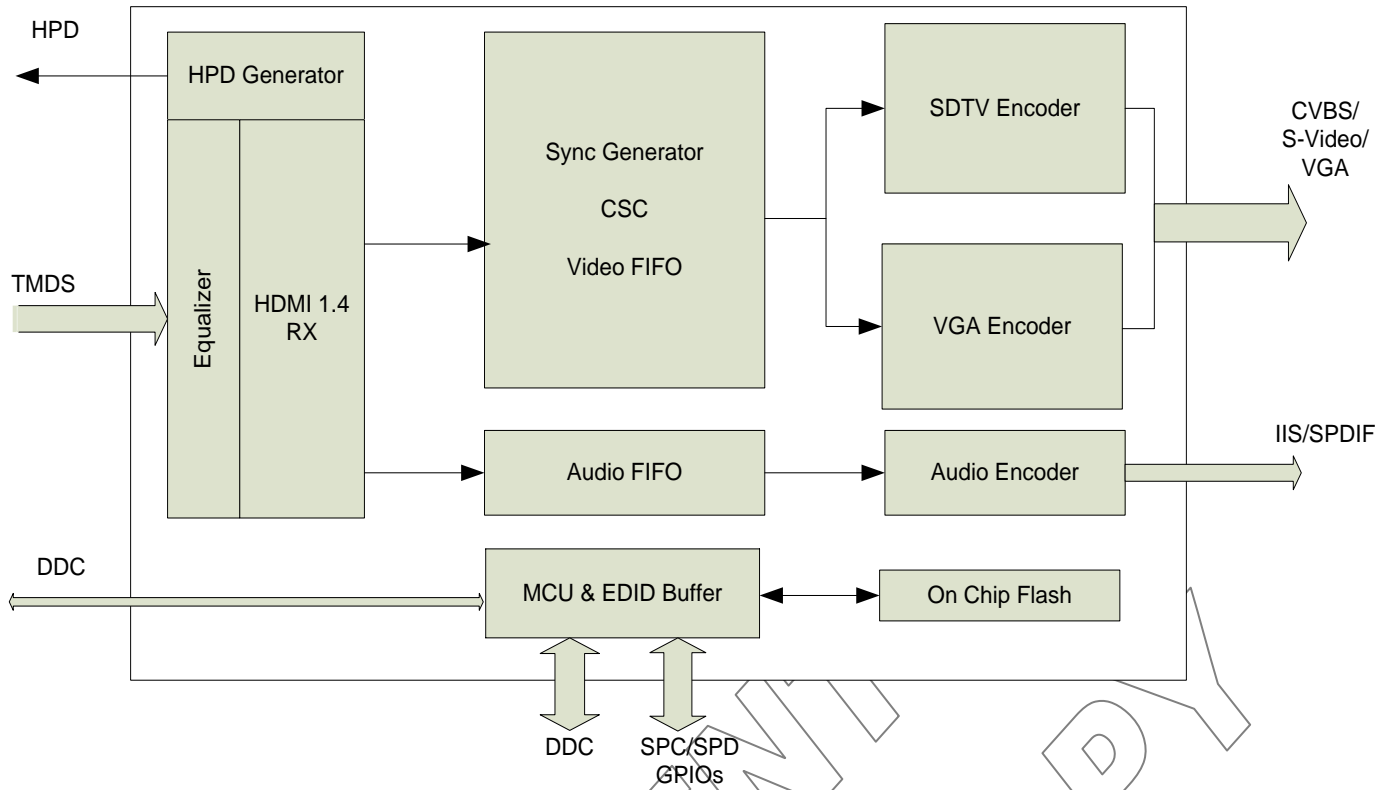

Figure 1: CH7105B Functional Block Diagram

CONFIDENTIAL
DO NOT COPY

1.0 PIN-OUT

1.1 Package Diagram

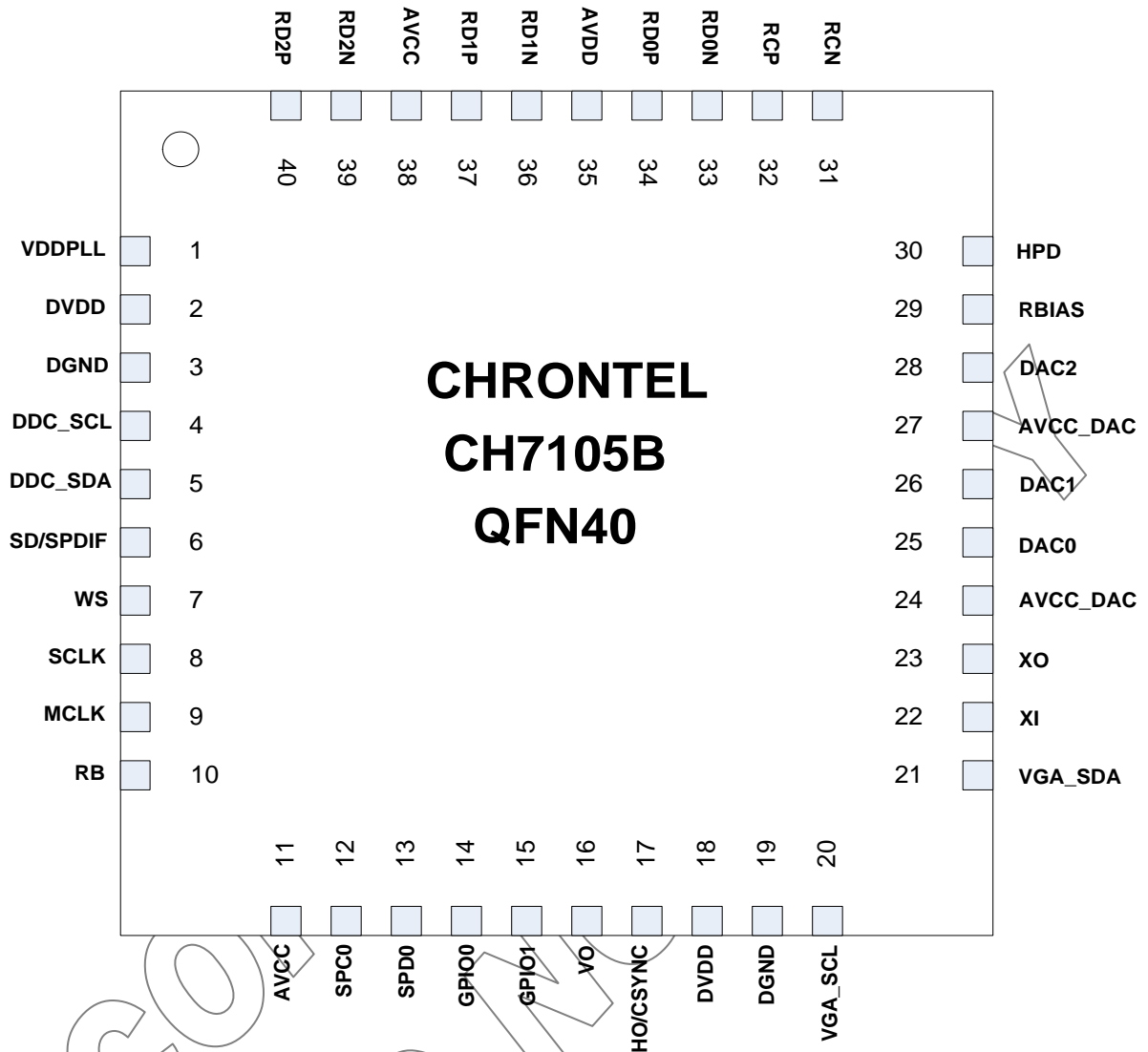

Figure 2: CH7105B 40-Pin QFN Pin Out

1.2 Pin Description

Table 1: Pin Name Descriptions

Pin #	Type	Symbol	Description
4	In	DDC_SCL	Serial Port Clock to HDMI/DVI Transmitter This pin functions as the clock bus of the serial port to HDMI or DVI DDC transmitter. This pin requires a pull-up 47 kΩ resistor to the desired voltage level.
5	In/out	DDC_SDA	Serial Port Data to HDMI/DVI Transmitter This pin functions as the data bus of the serial port to HDMI or DVI DDC transmitter. This pin requires a pull-up 47 kΩ resistor to the desired voltage level.
6	Out	SD/SPDIF	I2S Serial Data or SPDIF Output
7	Out	WS	I2S Word Select
8	Out	SCLK	I2S Continuous Serial Clock
9	Out	MCLK	I2S System Clock
10	In	RB	Chip Reset Low to 0V for reset. Typical High level is 3.3V
12	In	SPC0	Serial Port Clock Input This pin functions as the clock pin of the serial port. External pull-up 6.8 KΩ resistor is required
13	In/out	SPD0	Serial Port Data Input / Output This pin functions as the bi-directional data pin of the serial port. External pull-up 6.8 KΩ resistor is required
14,15	In/Out	GPIO	General Purpose Input/Output
16	Out	VO	Vertical Sync Signal Output The amplitude of this pin is from 0 to AVCC
17	Out	HO/CSYNC	Horizontal Sync Signal Output The amplitude of this pin is from 0 to AVCC It also functions as a Composite sync output
20	Out	VGA_SCL	Serial Port Clock Output to VGA Receiver The pin should be connected to clock signal of VGA DDC. This pin requires a pull-up 10 kΩ resistor to the desired voltage level
21	In/Out	VGA_SDA	Serial Port Data to VGA Receiver The pin should be connected to data signal of VGA DDC. This pin requires a pull-up 10 kΩ resistor to the desired voltage level
22	In	XI	Crystal Input A parallel resonance crystal should be attached between this pin and XO.
23	Out	XO	Crystal Output A parallel resonance crystal should be attached between this pin and XI. If an external CMOS clock is injected to XI, XO should be left open.
25	Out	DAC0	VGA Blue Component/S-Video C Component output
26	Out	DAC1	VGA Green Component/ S-Video Y Component output
28	Out	DAC2	VGA Red Component/ CVBS output
29	In	RBIAS	Current Set Resistor Input This pin sets the DAC current. A 10 KΩ, 1% tolerance resistor should be connected between this pin and AVSS using short and wide traces
30	Out	HPD	HDMI Receiver Hot Plug output
31,32,33, 34,36,37,	In	RD[2:0]P/N RCP/N	HDMI TMDS Input HDMI differential clock and data input pairs

39,40			
1	Power	VDDPLL	PLL Power Supply (1.2V)
2,18	Power	DVDD	Digital IO Power Supply (1.2V)
3,19	Power	DGND	Digital Ground
11,38	Power	AVCC	Analog Power Supply (3.3V)
24,27	Power	AVCC_DAC	Analog DAC Power Supply (3.3V)
35	Power	AVDD	HDMI Receiver Analog Power Supply (1.2V)
Pad	Power	GND	Power Supply Ground

CONFIDENTIAL
DO NOT COPY

2.0 PACKAGE DIMENSION

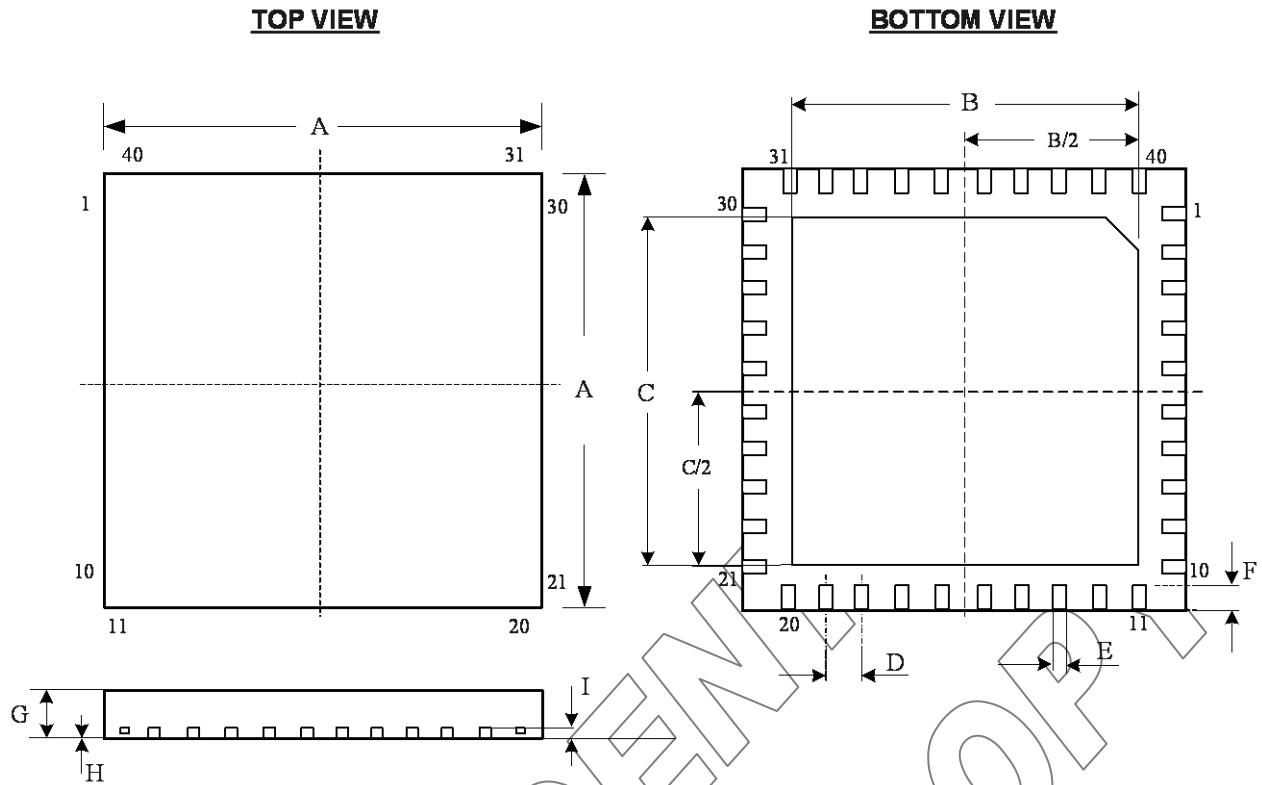

Figure 3: 40 Pin QFN Package

Table 2: Table of Dimensions

No. of Leads		SYMBOL								
40 (5 X 5 mm)		A	B	C	D	E	F	G	H	I
Milli-meters	MIN	4.90	3.20	3.20	0.4	0.15	0.35	0.70	0	0.203
	MAX	5.10	3.40	3.40		0.25	0.45	0.80	0.05	REF

Notes:

1. Conforms to JEDEC standard JESD-30 MO-220.

Disclaimer

This document provides technical information for the user. Chrontel reserves the right to make changes at any time without notice to improve and supply the best possible product and is not responsible and does not assume any liability for misapplication or use outside the limits specified in this document. CHRONTEL warrants each part to be free from defects in material and workmanship for a period of one (1) year from date of shipment. Chrontel assumes no liability for errors contained within this document. The customer should make sure that they have the most recent data sheet version. Customers should take appropriate action to ensure their use of the products does not infringe upon any patents. Chrontel, Inc. respects valid patent rights of third parties and does not infringe upon or assist others to infringe upon such rights.

Chrontel PRODUCTS ARE NOT AUTHORIZED FOR AND SHOULD NOT BE USED WITHIN LIFE SUPPORT SYSTEMS OR NUCLEAR FACILITY APPLICATIONS WITHOUT THE SPECIFIC WRITTEN CONSENT OF Chrontel. Life support systems are those intended to support or sustain life and whose failure to perform when used as directed can reasonably expect to result in personal injury or death.

ORDERING INFORMATION			
Part Number	Package Type	Operating Temperature Range	Minimum Order Quantity
CH7105B-BF	40 QFN, Lead-free	Commercial: 0 to 70°C	490/Tray
CH7105B-BFI	40 QFN, Lead-free	Industrial: -40 to 85°C	490/Tray

Chrontel

Chrontel International Limited

**129 Front Street, 5th floor,
Hamilton, Bermuda HM12**

**www.chrontel.com
E-mail: sales@chrontel.com**