

Chrontel CH7231A USB Type-C Electronically Marked Cable Component

Features

- Component for USB Type-C electronically marked cable (USB Type-C Specification 1.2)
- Support USB power delivery specification revision 2.0, version 1.3 and USB power delivery specification revision 3.0, version 1.1*
- Patent pending circuit to support USB power delivery specification BMC cable plug RX mask requirement
- On-chip programmable embedded flash to support customer specific VDOs
- On-chip clock generation
- Low BOM cost, no external components required
- Low power consumption – below 7.5mA
- Offered in TSOT and DFN packages
- ESD +/- 8kV for Human Body Model (HBM), +/- 500V for Charged Device Model (CDM)

* Note: only support basic functions for USB power delivery revision 3.0

General Description

The CH7231A supports the USB Type-C Electronically Marked Cable (E-Marker). The device is designed to follow the USB Type-C Specification 1.2, the USB Power Delivery Specification Revision 2.0, Version 1.3 and USB power delivery specification revision 3.0, version 1.1*. The CH7231A is a low cost semiconductor device and can help the cable manufacturer easily enabling the USB Power Delivery feature required by USB Type-C E-Mark cable. In order to reduce the cost of the cable material, The CH7231A integrates all necessary components and circuits, such as LDO, clock generation, isolation circuit, Ra, etc. The on-chip embedded flash allows cable to store VDOs commands specified by the Power Delivery specification that to be used for communication between provider and consumer.

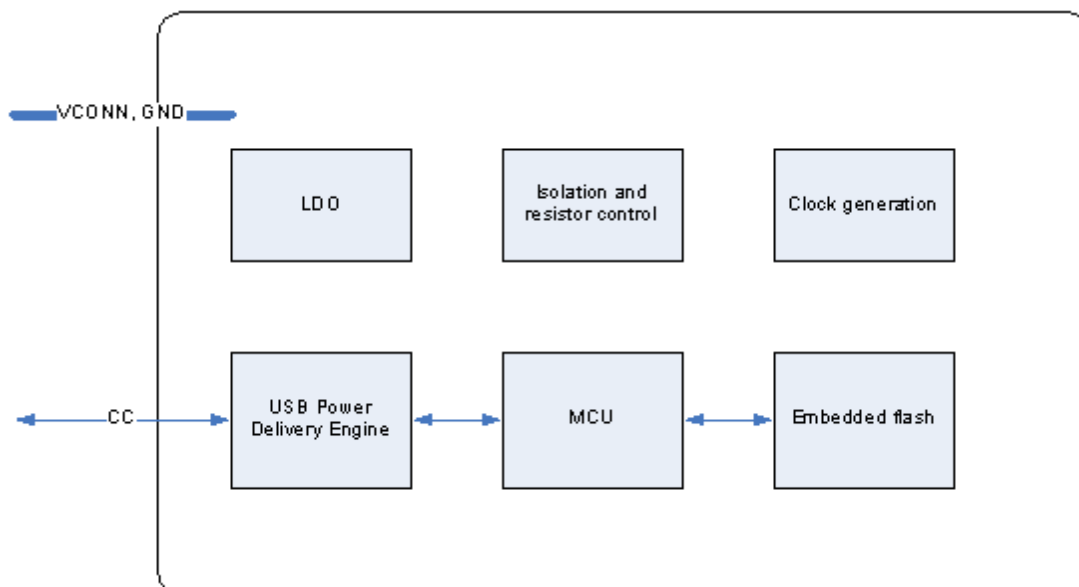

Figure 1: Functional Block Diagram

Table of Contents

- 1.0 Pin-Out4**
 - 1.1 Package Diagram4
 - 1.2 Pin Description5
- 2.0 Functional Description.....6**
 - 2.1 Clock Generation6
 - 2.2 Isolation6
 - 2.3 Resistor6
 - 2.4 USB Power Delivery Engine6
 - 2.4.1 Physical layer6
 - 2.4.2 Protocol layer6
 - 2.5 MCU6
 - 2.6 Embedded Flash.....6
- 3.0 Electrical Specifications7**
 - 3.1 Absolute Maximum Ratings7
 - 3.2 Recommended Operating Conditions7
 - 3.3 Electrical Characteristics7
 - 3.3.1 DC Specifications8
 - 3.3.2 AC Specifications8
- 4.0 Package Dimensions9**
- 5.0 Revision History.....11**

Figures and Tables

List of Figures

Figure 1: Functional Block Diagram 1
Figure 2: TSOT23-5 Pin Out 4
Figure 3: DFN-6 Pin Out 4
Figure 4: TSOT23-5 Package 9
Figure 5: DFN-6 Package 10

List of Tables

Table 1: Pin Description of TSOT23-5..... 5
Table 2: Pin Description of DFN-6..... 5
Table 3: Absolute Maximum Ratings 7
Table 4: Absolute Maximum Ratings 7
Table 5: DC Specifications 8
Table 6: AC Specifications 8
Table 7: Revision History 11
Table 8: Ordering Information..... 12

1.0 Pin-Out

1.1 Package Diagram

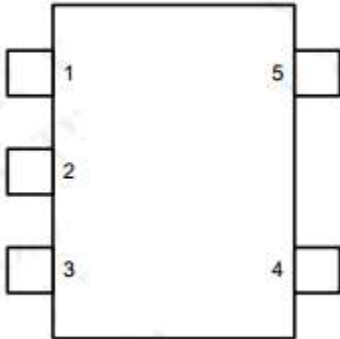

Figure 2: TSOT23-5 Pin Out

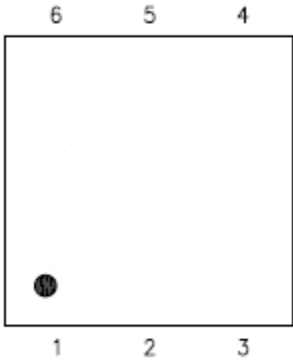

Figure 3: DFN-6 Pin Out

1.2 Pin Description

Pin #	Type	Symbol	Description
1	Power	VCONN2*	Vconn #2 This pin connects to VCONN of the plug on the other side of the USB Type-C cable.
2	NC		No Connection
3	In/Out	CC	CC This pin connects to CC of the plugs on both sides of the USB Type-C cable.
4	Power	GND	Ground
5	Power	VCONN1*	Vconn #1 This pin connects to VCONN of the plug on one side of the USB Type-C cable.

Table 1: Pin Description of TSOT23-5

Pin #	Type	Symbol	Description
1	Power	VCONN1*	Vconn #1 This pin connects to VCONN of the plug on one side of the USB Type-C cable.
2	NC		No Connection
3	Power	GND	Ground
4	In/Out	CC	CC This pin connects to CC of the plugs on both sides of the USB Type-C cable. It also functions as the control I/O when different frequency is used.
5	NC		No Connection
6	Power	VCONN2*	Vconn #2 This pin connects to VCONN of the plug on the other side of the USB Type-C cable.

Table 2: Pin Description of DFN-6

***Note: VCONN1 and VCONN2 are interchangeable.**

2.0 Functional Description

2.1 Clock Generation

The CH7231A equips with on-chip clock and no external crystal is needed.

2.2 Isolation

Each USB Type-C Electronically Marked Cable requires one CH7231A. The isolation for Vconn required by the USB Type-C Specification is implemented on chip and there is no need to add external components to achieve the isolation of Vconn.

2.3 Resistor

The Ra resistor specified by the USB Type-C standard is incorporated in the CH7231A hardware circuits. Additional off-chip resistors are not required to support the CH7231A device. Also, the CH7231A meets the 7.5mA power-down maximum current and the Ra resistance increases when Vconn is properly supplied, which is allowed by the USB Type-c standard.

2.4 USB Power Delivery Engine

2.4.1 Physical layer

The physical layer of the USB Power Delivery engine includes the BMC codec, symbol (4b5b) codec, CRC, packets format/decode and order sets processing.

2.4.2 Protocol layer

The protocol layer of the CH7231A device handles the state machines, timers, control/data messages, etc.

2.5 MCU

Each CH7231A has an on-chip 8-bit MCU. It receives VDOs message commands from the CH7231A's USB Power Delivery engine, processes it, and generates proper response.

2.6 Embedded Flash

A 2K-byte flash is embedded in the CH7231A. It holds the MCU program and other key parameters required for the chip to be functional. It needs to be initialized and programmed during the production test before shipping to end customers.

3.0 Electrical Specifications

3.1 Absolute Maximum Ratings

Symbol	Description	Min	Typ	Max	Units
V_{VCONN}	VCONNx voltage relative to GND	-0.5		5.5	V
	CC pin input voltage	GND-0.5		V_{VCONN}	V
T_{STOR}	Storage temperature	-65		150	°C
T_J	Junction temperature			150	°C
T_{VPS}	Vapor phase soldering (5 seconds)			260	°C
	Vapor phase soldering (11 seconds)			245	°C
	Vapor phase soldering (60 seconds)			225	°C

Table 3: Absolute Maximum Ratings

Note:

- 1) Stresses greater than those listed under absolute maximum ratings may cause permanent damage to the device. These are stress ratings only. Functional operation of the device at these or any other conditions above those indicated under the normal operating condition of this specification is not recommended. Exposure to absolute maximum rating conditions for extended periods may affect reliability.
- 2) The device is fabricated using high-performance CMOS technology. It should be handled as an ESD sensitive device. Voltage on any signal pin that exceeds the power supply voltages by more than $\pm 0.5V$ can induce destructive latchup.

3.2 Recommended Operating Conditions

Symbol	Description	Min	Typ	Max	Units
V_{VCONN}	VCONNx supply voltage	3	5.0	5.5	V
T_{AMB}	Ambient operating temperature	0		70	°C

Table 4: Absolute Maximum Ratings

3.3 Electrical Characteristics

T_{AMB} = room temperature, V_{VCONN} = 5.0V, unless otherwise noted.

3.3.1 DC Specifications

Symbol	Description	Min	Typ	Max	Units	Symbol
V _{VCONN}	VCONNx supply voltage		3*		5.5	V
I _{VCONN}	VCONNx supply current	VCONN1 = V _{VCONN} or VCONN2 = V _{VCONN}		4.5		mA
V _{OH,CC}	CC output high voltage			1.125		V
V _{OL,CC}	CC output low voltage			50		mV
R _{ra}	Internal R _a resistor on VCONNx pin	VCONNx not powered. R _p =10K, R _d =5.1K, V _{PU} =5V		1000		ohm

Table 5: DC Specifications

3.3.2 AC Specifications

Symbol	Description	Min	Typ	Max	Units	Symbol
f _{BitRate}	CC output bit rate			300		Kbps
T _{r,CC}	CC output rise time	10% to 90%		450		nS
T _{f,CC}	CC output fall time	90% to 10%		450		nS

Table 6: AC Specifications

*Note: for 3V support, please check with ChronTEL for more details

4.0 Package Dimensions

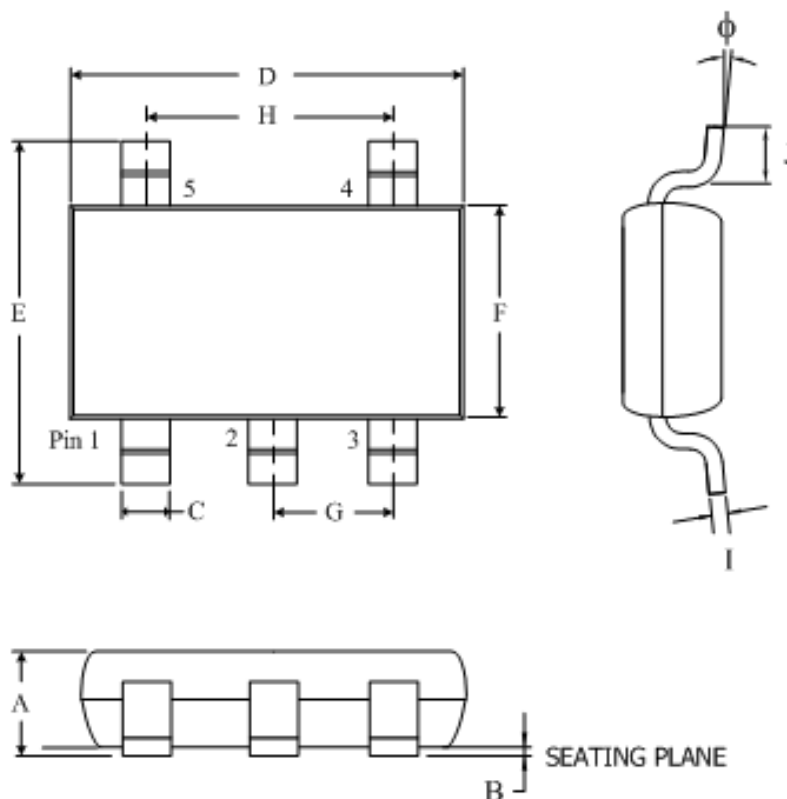

Table of Dimensions

No. of Leads		SYMBOL										
5		A	B	C	D	E	F	G	H	I	J	ϕ
Milli- meters	MIN	0.90	0.01	0.30	2.82	2.65	1.60	0.90	1.80	0.08	0.30	0°
	MAX	1.00	0.15	0.50	3.05	2.95	1.70	1.00	2.00	0.20	0.60	8°

Figure 4: TSOT23-5 Package

Notes:

All dimensions refer to JEDEC standard MO-193

Do not include Mold flash or protrusions.

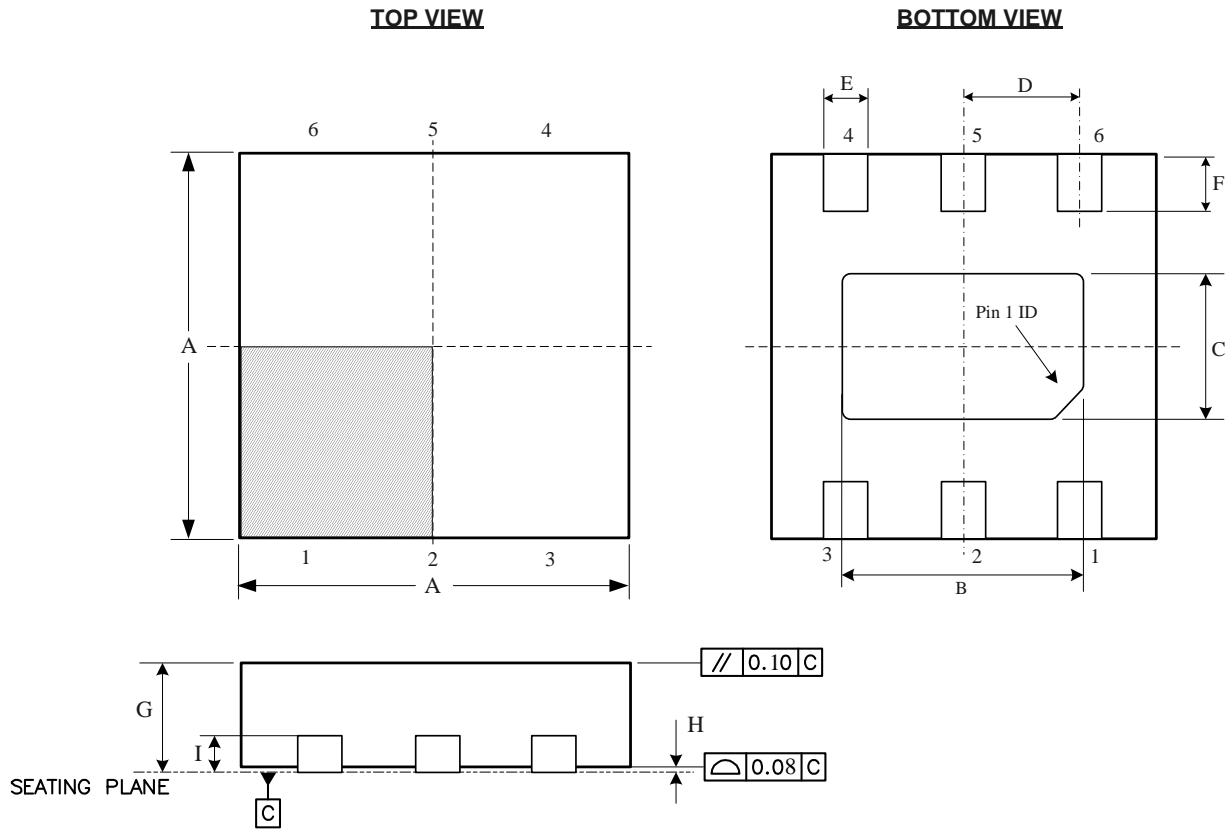

Table of Dimensions

No. of Leads		SYMBOL								
6 (2 x 2 x 0.8 mm)		A	B	C	D	E	F	G	H	I
Milli-meters	MIN	1.90	1.30	0.70	0.65	0.20	0.25	0.57	0	0.15 to 0.20 TYP
	MAX	2.10	1.75	1.06		0.35	0.40	0.80	0.05	

Figure 5: DFN-6 Package

5.0 Revision History

Rev. #	Date	Section	Description
0.9	08/13/15	All	Based on previous internal revisions Remove DFN Modify PD traffic Add some parameter on Typs in 3.1 section Add Pattern Pending line in the “Features” Change USB Type-C Spec. version to 1.1 Change USB Power Delivery Spec. to version 1.1
1.0	05/09/16	“Features” “Figures and Tables” 3.1 Ordering Information	Change USB Type-C Spec. version to 1.2 Change USB Power Delivery Spec. to version 1.2 Add Figure 3. Add Table 3, 4, 5, 6, 7 Add some parameter on Vvconn in 3.1 section Add Table 7: Ordering Information
1.1	02/21/17	All	Add DFN-6 Package Diagram, Pin Description and Package Dimension Add ESD Features Add DFN-6 Ordering Information Modify some DC parameter
2.0	04/17/17	All	Change CH7231 to CH7231A
3.0	7/26/17	All	Minor changes for standard revision updates and operating conditions

Table 7: Revision History

Disclaimer

This document provides technical information for the user. Chrontel reserves the right to make changes at any time without notice to improve and supply the best possible product and is not responsible and does not assume any liability for misapplication or use outside the limits specified in this document. CHRONTEL warrants each part to be free from defects in material and workmanship for a period of one (1) year from date of shipment. Chrontel assumes no liability for errors contained within this document. The customer should make sure that they have the most recent data sheet version. Customers should take appropriate action to ensure their use of the products does not infringe upon any patents. Chrontel, Inc. respects valid patent rights of third parties and does not infringe upon or assist others to infringe upon such rights.

Chrontel PRODUCTS ARE NOT AUTHORIZED FOR AND SHOULD NOT BE USED WITHIN LIFE SUPPORT SYSTEMS OR NUCLEAR FACILITY APPLICATIONS WITHOUT THE SPECIFIC WRITTEN CONSENT OF Chrontel. Life support systems are those intended to support or sustain life and whose failure to perform when used as directed can reasonably expect to result in personal injury or death.

ORDERING INFORMATION					
Part Number	Package Type	Number of Pins	Voltage Supply	Quantity	Temperature Grade
CH7231A-EF-TR	TSOT23-5	5		3K/reel MOQ	Commercial / Automotive Grade 4
CH7231A-CF-TR	DFN6	6		3K/reel MOQ	Commercial / Automotive Grade 4

Table 8: Ordering Information

Chrontel

**2210 O'Toole Avenue, Suite 100,
San Jose, CA 95131-1326
Tel: (408) 383-9328
Fax: (408) 383-9338
www.chrontel.com
E-mail: sales@chrontel.com**