

12.5-17GHz Low-Noise Driver Amplifier GaAs Monolithic Microwave IC

Description

The CHA2266-99F is a self biased, low-noise high gain driver amplifier. It is designed mainly for VSAT applications in Ku-band. The backside of the chip is both RF and DC grounded. This helps to simplify the assembly process.

The circuit is manufactured on a standard GaAs pHEMT process, with via holes through the substrate, air bridges and electron beam gate lithography.

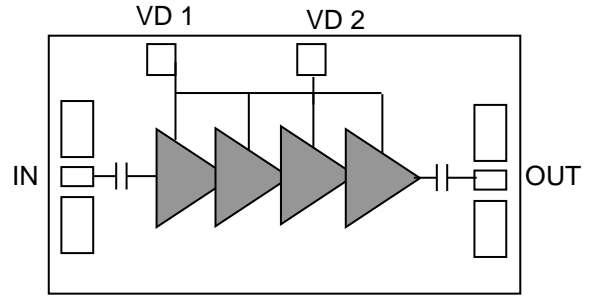

It is available in chip form

Main Features

- Broadband performance 12.5–17GHz
- 2.5dB noise figure
- 34dB gain, +/- 0.5dB gain flatness
- Low DC power consumption: 130mA
- Saturated output power : 16dBm
- Chip size 2.32 x 1.02 x 0.1mm

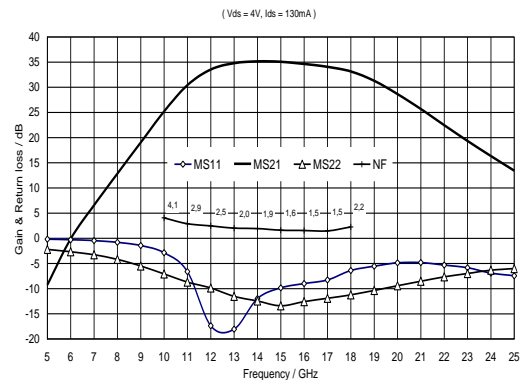

Main Characteristics

Tamb=+25°C

Symbol	Parameter	Min	Typ	Max	Unit
Fop	Operating frequency range	12.5		17	GHz
G	Small signal gain	31	34		dB
NF	Noise Figure		2.5	3	dB
P1dB	Output power at 1 dB gain compression		14.5		dBm

ESD Protection : Electrostatic discharge sensitive device. Observe handling precautions !

Electrical Characteristics on wafer

Tamb = +25°C, Vd = 4V

Symbol	Parameter	Min	Typ	Max	Unit
Fop	Operating frequency range	12.5		17	GHz
G	Small signal gain	31	34		dB
ΔG	Small signal gain flatness		± 0.5		dB
NF	Noise Figure		2.5	3.0	dB
RLin	Input return loss		-10	-6	dB
RLout	Output return loss		-10	-6	dB
P1dB	Output power at 1 dB gain compression	13.5	14.5		dBm
P3dB	Saturated output power	15	16		
Id small signal	Drain bias current		130	170	mA
Rth	Thermal resistance @ Tback side=25°C		80°C		°C/W

Absolute maximum Ratings (1)

Symbol	Parameter	Values	Unit
Vd	Drain bias voltage	4.3	V
Pin	Maximum continuous input power overdrive	-15	dBm
	Maximum peak input power overdrive(2)	+15	dBm
Tj max	Maximum junction temperature	175	°C
Top	Operating temperature range	-40 to +85	°C
Tstg	Storage temperature	-55 to +150	°C

(1) Operation of this device above any of these parameters may cause permanent damage.

(2) Duration <1s

Typical Results

Typical Chip Response (On wafer S-parameter*)

(Vds = 4V, Ids = 130mA)

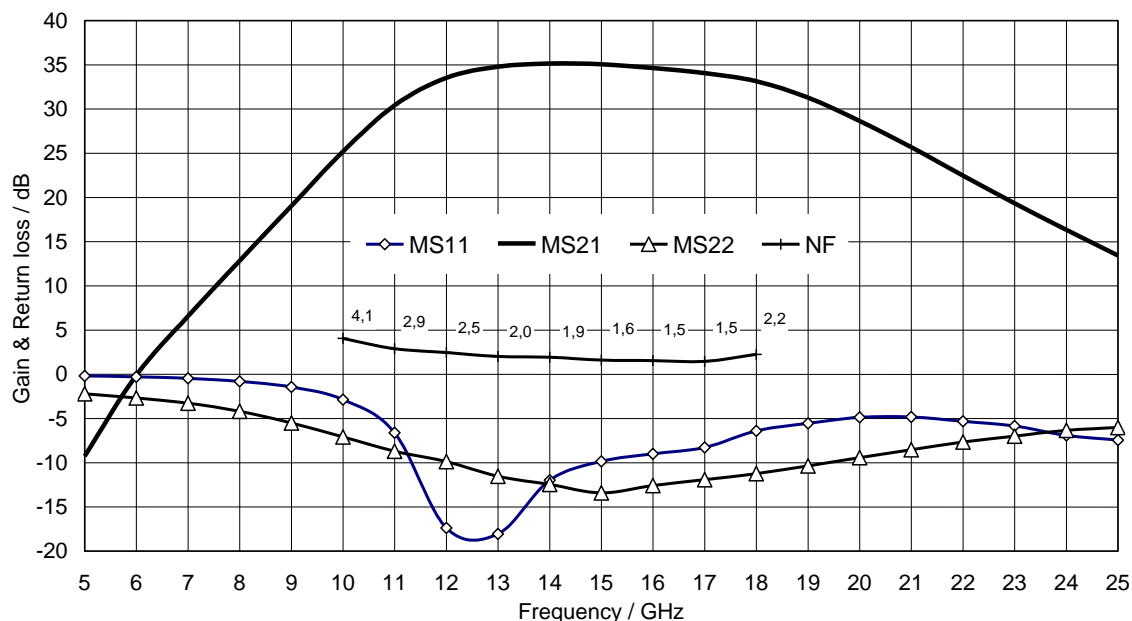

*Return loss improves with bondings

Typical On Wafer Scattering Parameters

Tamb = +25°C, Bias Conditions: Vd = 4V

Freq/GHz	MS11	PS11	MS12	PS12	MS21	PS21	MS22	PS22	NF
5.00	-0.19	-60.43	-80.46	-28.08	-9.27	55.33	-2.21	-70.44	
6.00	-0.30	-74.26	-78.78	-70.24	-0.12	-24.96	-2.68	-82.41	
7.00	-0.46	-89.33	-75.88	2.69	6.56	-88.05	-3.27	-95.03	
8.00	-0.80	-106.32	-72.20	32.17	12.83	-142.23	-4.19	-107.99	
9.00	-1.44	-125.75	-73.72	-51.84	19.02	165.74	-5.51	-118.06	
10.00	-2.86	-151.22	-66.33	-115.35	25.20	108.42	-7.08	-126.35	4.06
11.00	-6.63	177.56	-70.35	-76.43	30.42	42.05	-8.70	-131.49	2.88
12.00	-17.39	153.85	-66.55	-128.54	33.53	-28.39	-9.87	-134.03	2.46
13.00	-18.06	-84.40	-65.32	168.52	34.77	-94.85	-11.53	-135.84	2.01
14.00	-12.00	-98.21	-59.86	-136.83	35.15	-154.68	-12.46	-131.75	1.92
15.00	-9.86	-113.78	-76.73	168.29	35.05	149.44	-13.41	-127.10	1.60
16.00	-9.01	-121.29	-56.32	80.85	34.64	97.72	-12.58	-114.59	1.55
17.00	-8.27	-129.83	-57.21	-170.04	34.05	46.71	-11.91	-113.66	1.46
18.00	-6.40	-139.02	-62.54	-89.64	33.15	-4.88	-11.24	-113.55	2.24
19.00	-5.55	-156.24	-65.06	53.72	31.28	-55.40	-10.37	-116.41	
20.00	-4.88	-174.36	-67.73	-90.69	28.65	-101.56	-9.43	-117.46	
21.00	-4.83	166.53	-55.41	154.09	25.68	-143.31	-8.53	-120.11	
22.00	-5.31	149.22	-53.79	91.59	22.47	-179.42	-7.66	-125.61	
23.00	-5.85	132.80	-52.72	-168.14	19.33	148.56	-7.00	-131.61	
24.00	-6.91	118.54	-50.50	80.81	16.33	119.70	-6.35	-137.67	
25.00	-7.45	103.68	-71.86	-7.37	13.42	93.05	-6.02	-145.44	



Typical Test-Jig Results

S- Parameters @ small signal

Tamb 25 °C, Vd = 4V

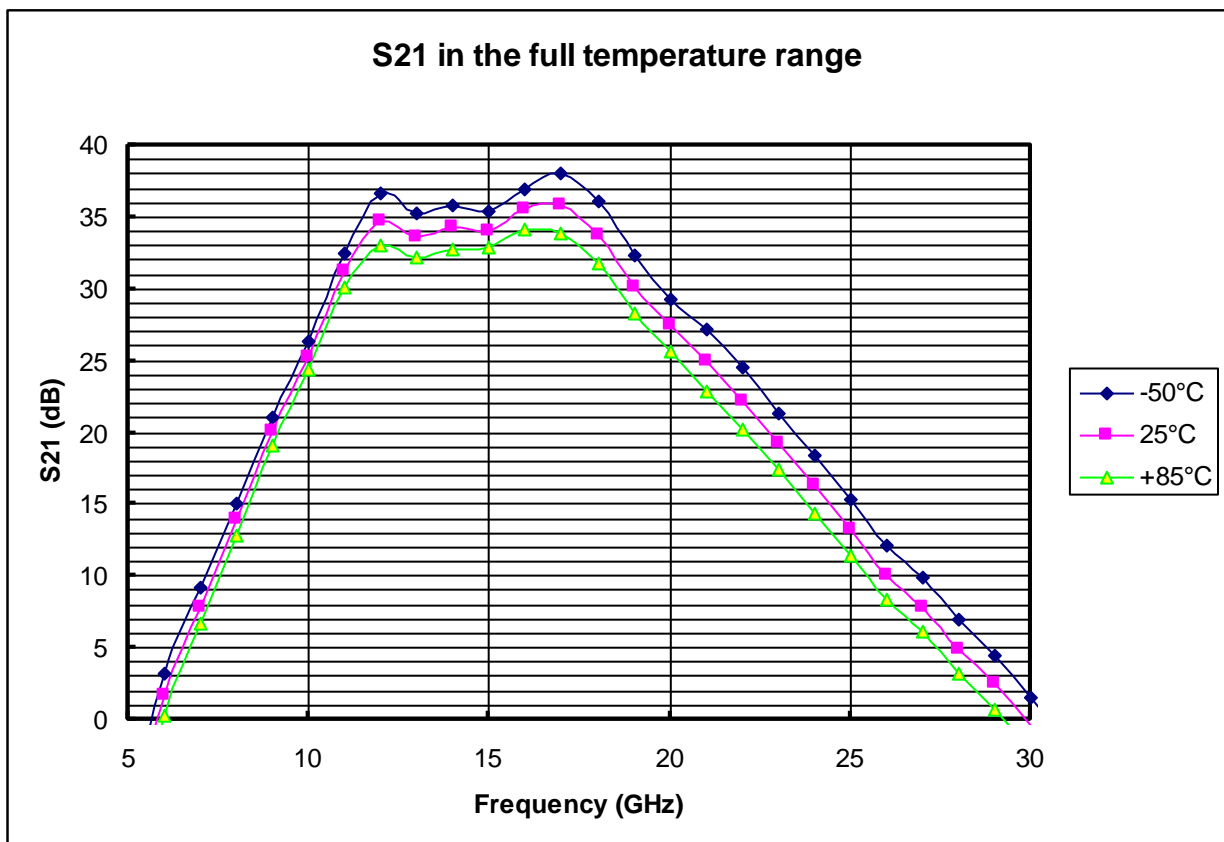
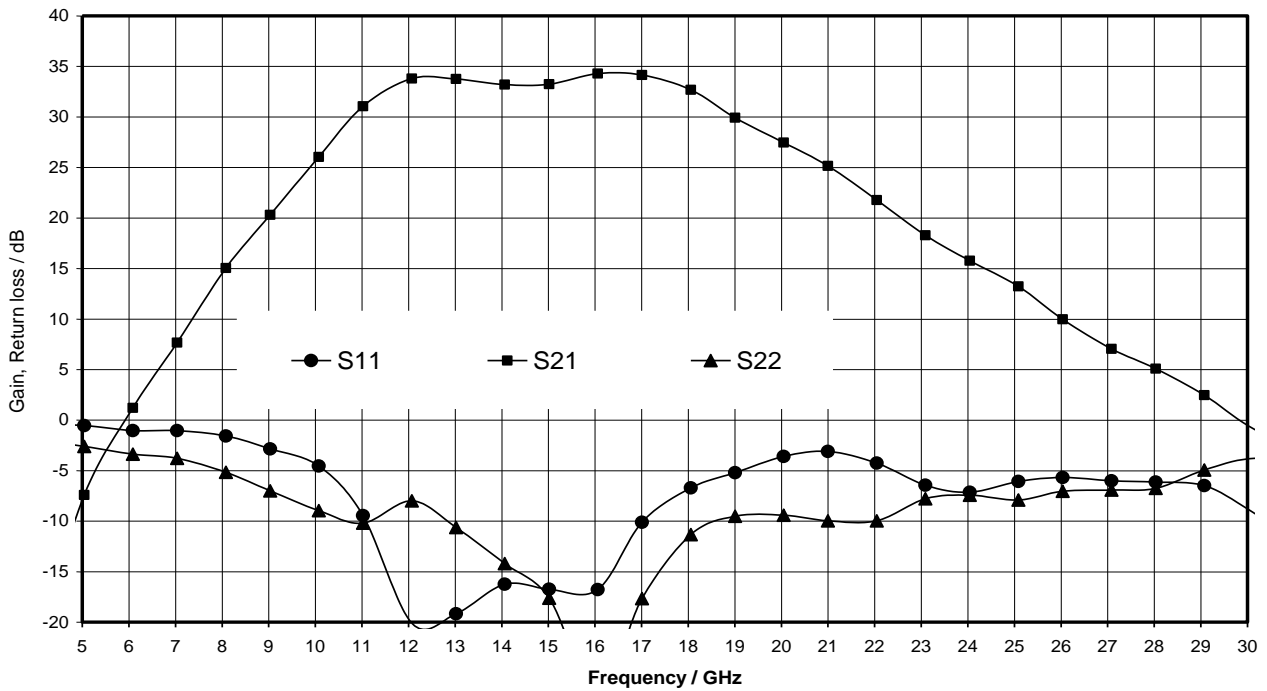

NF vs Frequency and Temperature

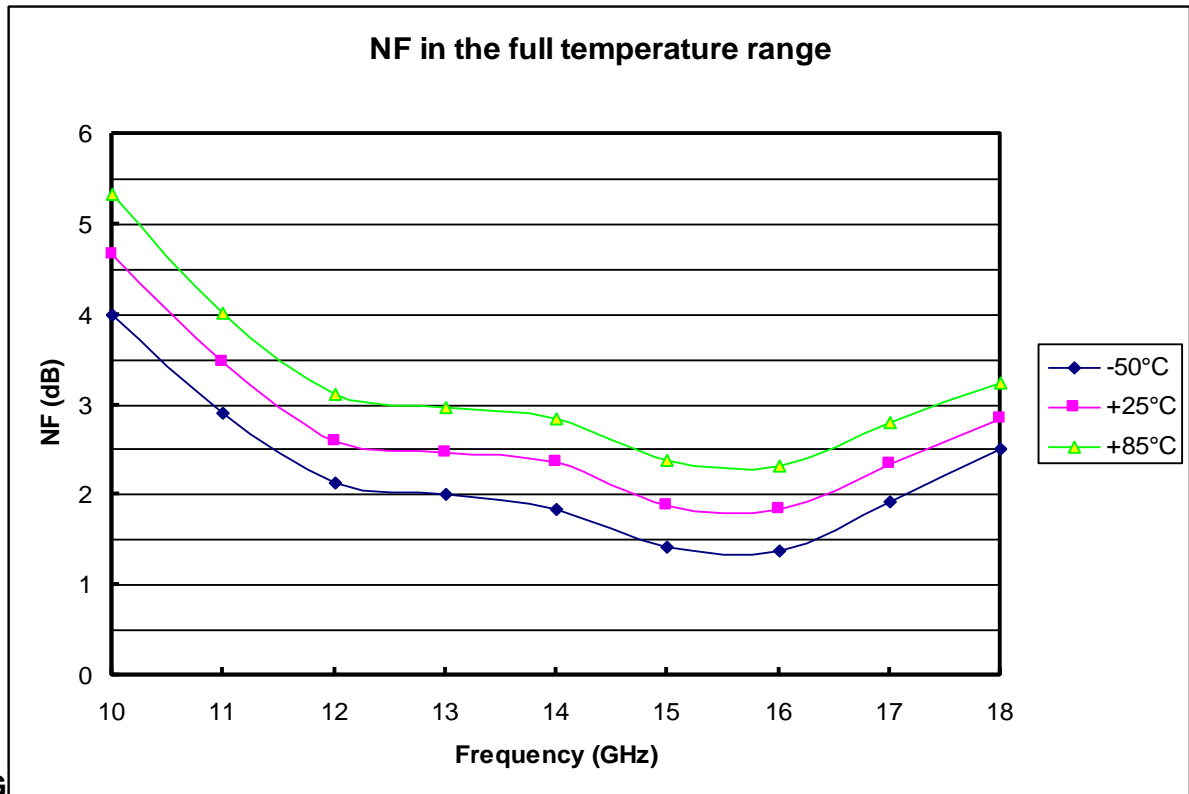

G
Tamb = 25°C, Vd = 4 V

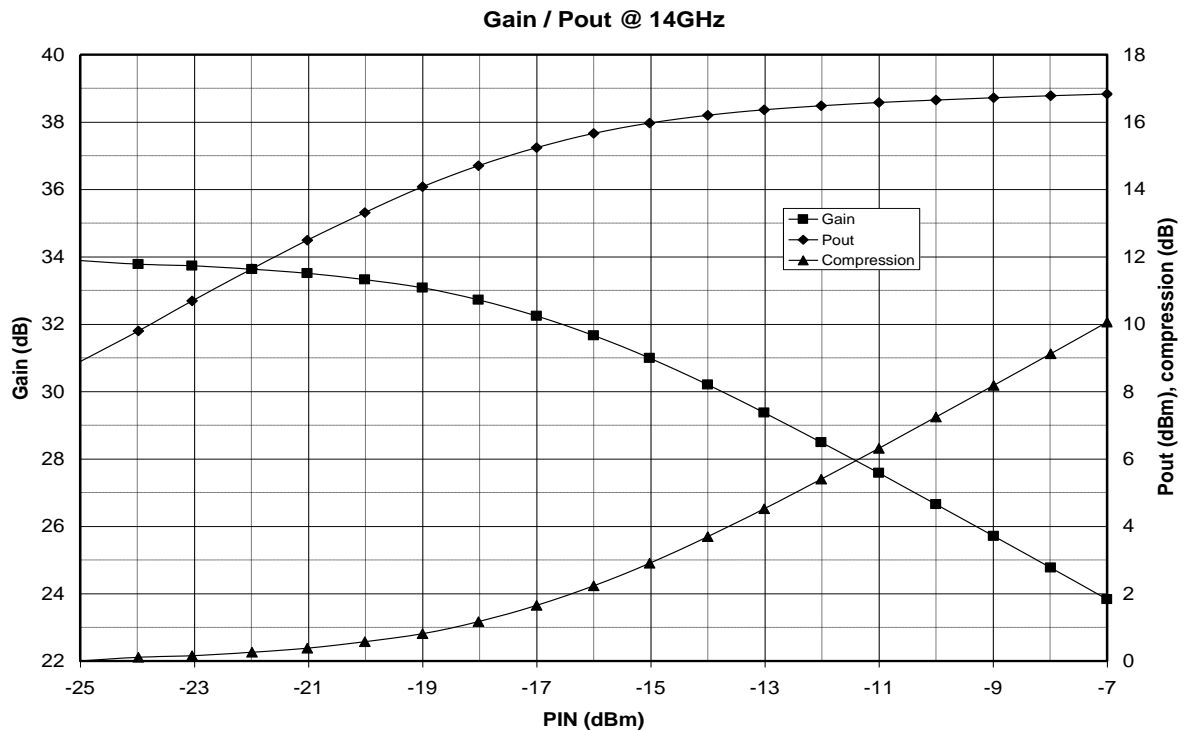

Gain / Pout @ 15GHz

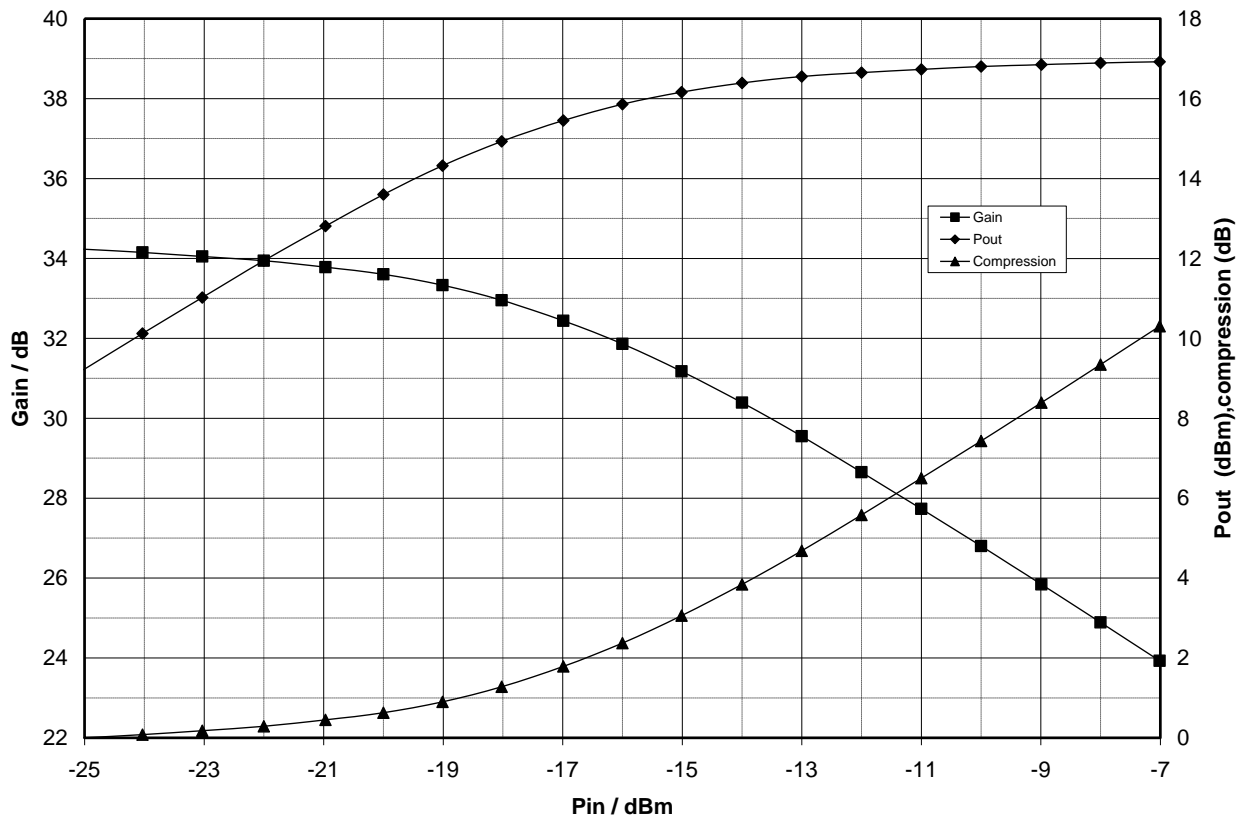

Gain / Pout @ 16GHz

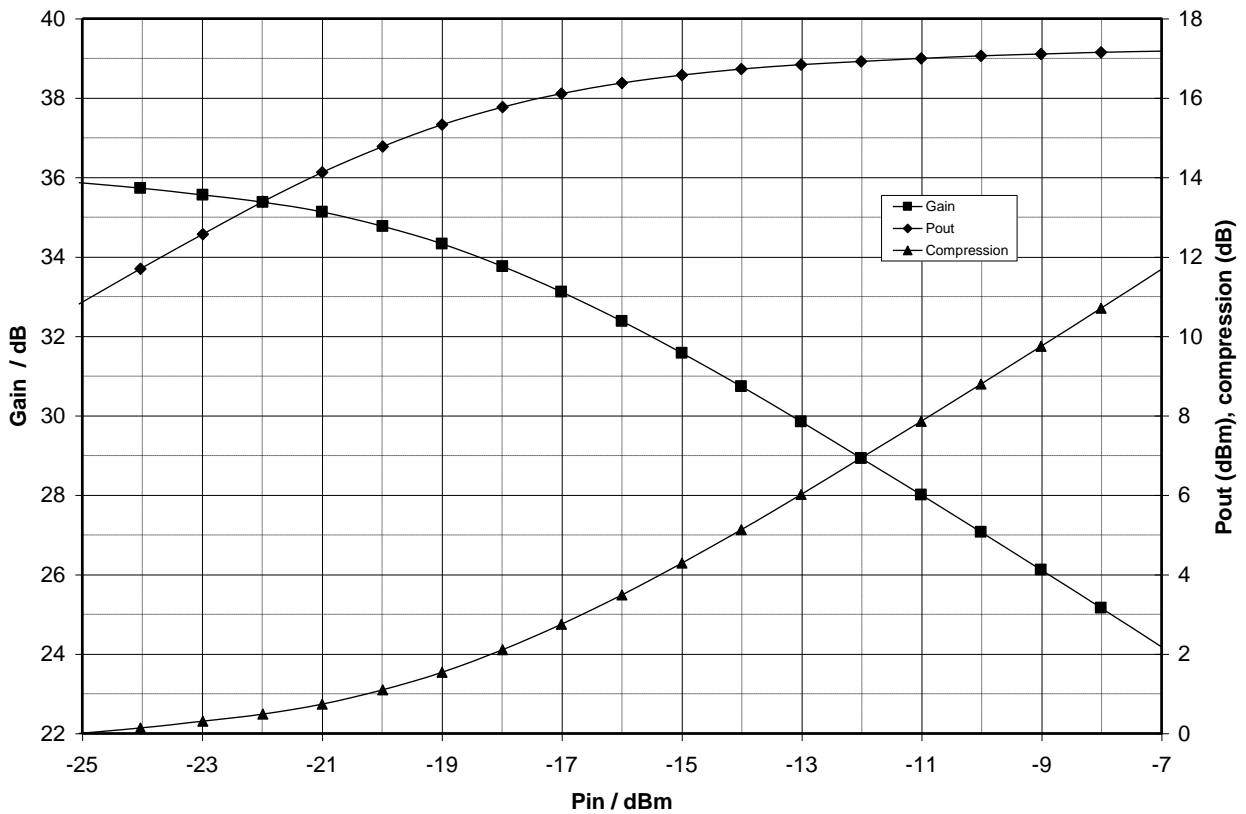

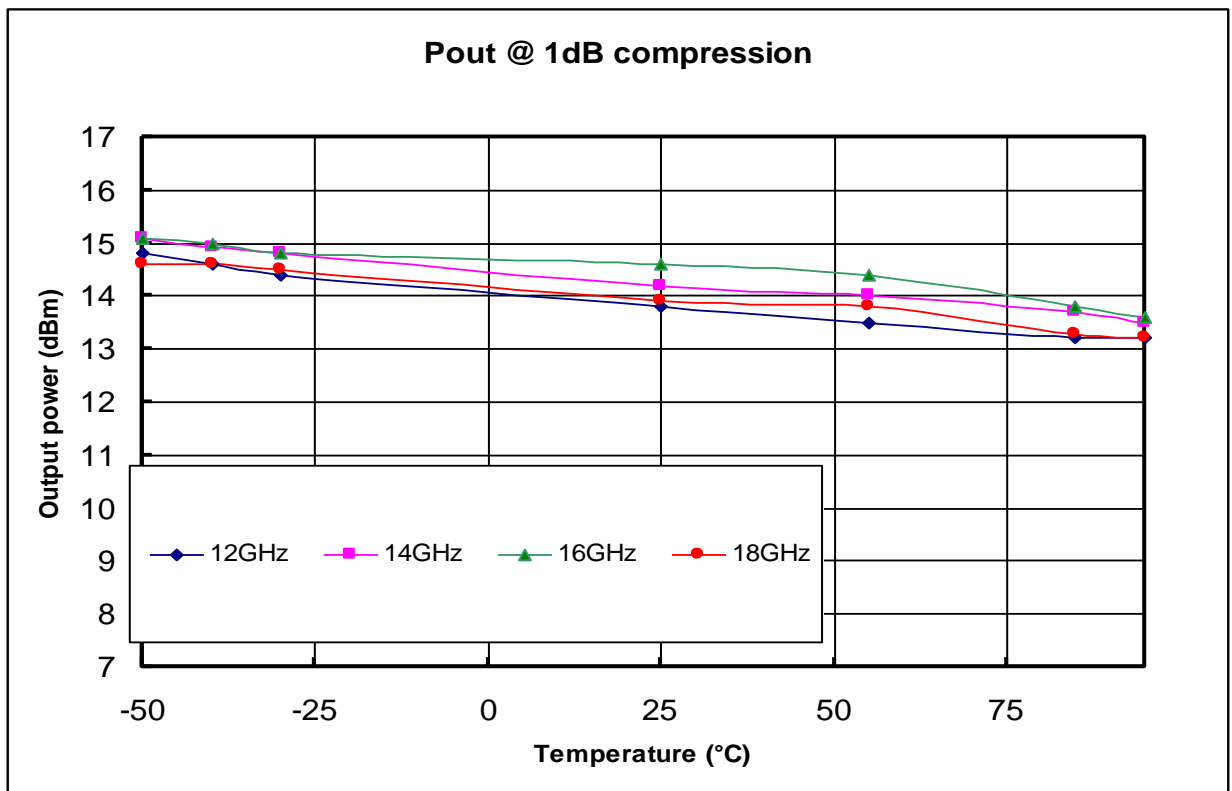
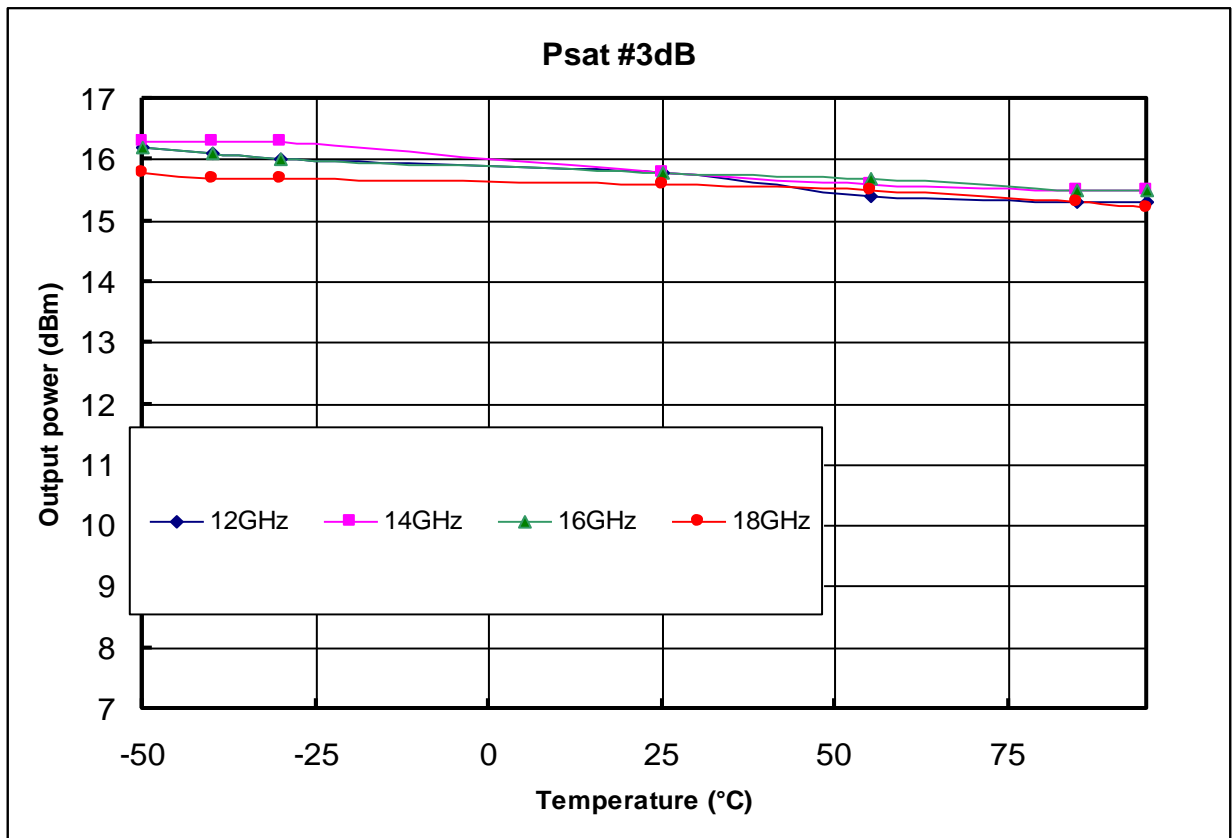

Chip Assembly and Mechanical Data

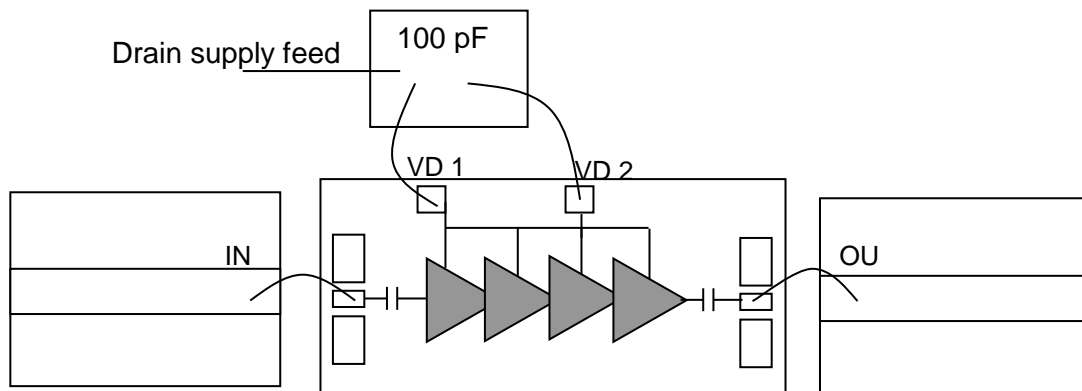

Notes: Vd1 & Vd2 pads are internally connected
Supply feed should be bypassed. 25µm diameter gold wire is recommended

Bond pad positions and Pin references

(Chip thickness: 100 µm. all dimensions are in micrometers)

Dimensions : 2320 x 1020µm ± 35µm

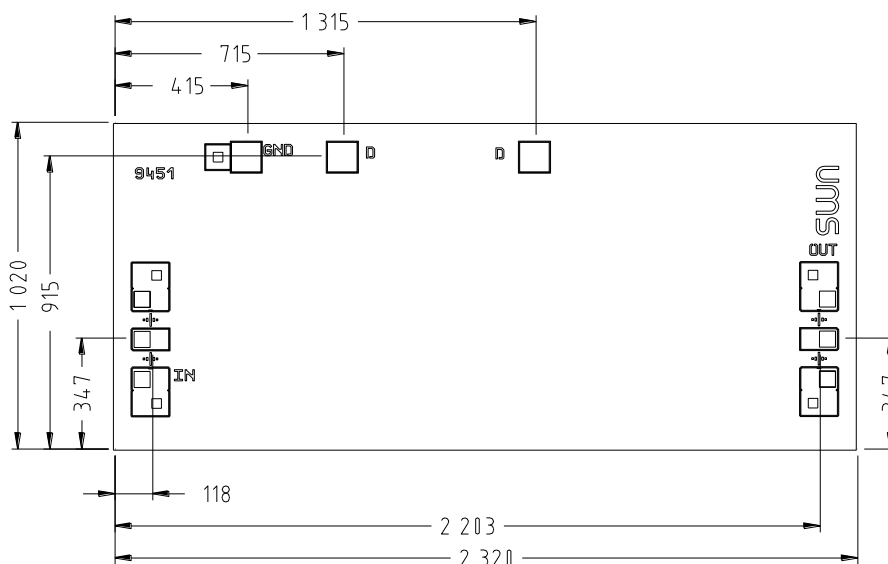

Ordering Information

Chip Form : CHA2266-99F/00

Information furnished is believed to be accurate and reliable. However **United Monolithic Semiconductors S.A.S.** assumes no responsibility for the consequences of use of such information nor for any infringement of patents or other rights of third parties which may result from its use. No license is granted by implication or otherwise under any patent or patent rights of **United Monolithic Semiconductors S.A.S.**. Specifications mentioned in this publication are subject to change without notice. This publication supersedes and replaces all information previously supplied. **United Monolithic Semiconductors S.A.S.** products are not authorised for use as critical components in life support devices or systems without express written approval from **United Monolithic Semiconductors S.A.S.**