

36-40GHz Very Low Noise High Gain Amplifier GaAs Monolithic Microwave IC

Description

The CHA2394-99F is a three-stage monolithic low noise amplifier. It is designed for a wide range of applications, from military to commercial communication systems.

The circuit is manufactured with a pHEMT process 0.25 μ m gate length, via holes through the substrate, air bridges and electron beam gate lithography. It is available in chip form.

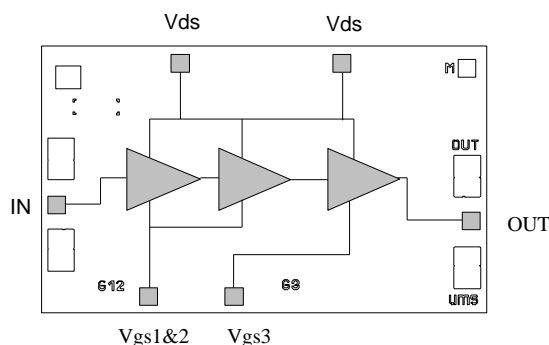

Main Features

- Broadband performances: 36-40GHz
- 2.5dB Noise Figure
- 21dB gain
- ± 1.5 dB gain flatness
- Low DC power consumption, 60mA@3.5V
- Chip size: 1.72 X 1.08 X 0.10 mm

Typical on wafer measurements

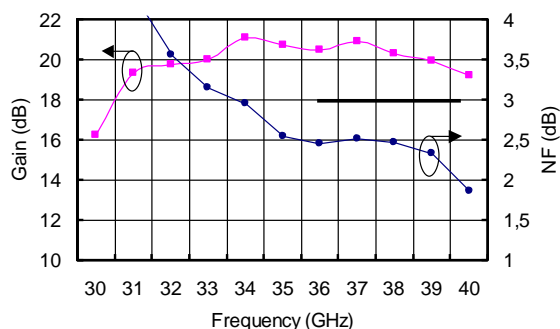

Main Electrical Characteristics

Tamb. = 25°C

Symbol	Parameter	Min	Typ	Max	Unit
Fop	Operating frequency range	36		40	GHz
G	Small signal gain	18	21		dB
P1dB	Output power at 1dB gain compression	8	12		dBm
NF	Noise figure		2.5	3.0	dB

ESD Protection : Electrostatic discharge sensitive device. Observe handling precautions !

Electrical Characteristics

Tamb = +25°C, Vd1, 2, 3 = 3.5V

Symbol	Parameter	Min	Typ	Max	Unit
Fop	Operating frequency range (1)	36		40	GHz
G	Small signal gain (1)	18	21		dB
ΔG	Small signal gain flatness (1)		± 1.5		dB
ΔG_{sb}	Gain flatness over 40MHz (within -30 ; +75°C)	0.5			dBpp
Is	Reverse isolation (1)	25	30		dB
P1dB	Output power at 1dB gain compression	5	8		dBm
VSWRin	Input VSWR (1)		2.5:1	3.0:1	
VSWRout	Output VSWR (1)		2.5:1	3.0:1	
NF	Noise figure (2)		2.5	3.0	dB
Vd	DC Voltage Vd Vg	-2	3.5 -0.25	4 +0.4	V V
Id	Bias current (2)		60		mA

(1) These values are representative of on-wafer measurements that are made without bonding wires at the RF ports.

(2) 60 mA is the typical bias current used for on wafer measurements, with Vg1, 2 = Vg3. For optimum noise figure, the bias current could be reduced down to 40 mA, adjusting the Vg1, 2 voltage.

Absolute Maximum Ratings (1)

Tamb. = 25°C

Symbol	Parameter	Values	Unit
Vd	Drain bias voltage	5.0	V
Id	Drain bias current	150	mA
Vdg	Maximum drain to gate voltage (Vd - Vg)	+5.0	V
Vg	Gate bias voltage	-2.0 to +0.4	V
Pin	Maximum peak input power overdrive (2)	+15	dBm
Pin	Maximum continuous input power	-5	dBm
Ta	Operating temperature range	-40 to +85	°C
Tstg	Storage temperature range	-55 to +150	°C

(1) Operation of this device above anyone of these parameters may cause permanent damage.

(2) Duration < 1s.

Typical Scattering Parameters (*On wafer Sij measurements*)

Bias Conditions : Vd = 3.5 Volt, Id = 60 mA.

Freq. GHz	S11 dB	S11 /°	S12 dB	S12 /°	S21 dB	S21 /°	S22 dB	S22 /°
20,00	-2,75	120,50	-48,15	148,90	-29,86	60,85	-8,63	-167,63
21,00	-2,67	112,34	-47,38	124,38	-30,25	88,05	-8,34	-172,68
22,00	-2,61	103,14	-46,75	104,04	-27,37	109,54	-8,61	-179,98
23,00	-2,64	93,91	-47,13	86,03	-24,34	126,91	-8,92	172,06
24,00	-2,70	84,09	-47,59	78,03	-19,83	140,52	-9,57	163,86
25,00	-2,86	73,06	-47,20	57,56	-14,48	146,82	-10,03	156,11
26,00	-3,14	60,56	-48,55	43,27	-8,77	144,71	-10,82	146,54
27,00	-3,69	45,51	-51,10	30,27	-2,99	136,53	-12,09	136,06
28,00	-4,64	26,86	-53,09	53,09	3,00	121,47	-13,97	127,00
29,00	-6,67	1,63	-49,95	40,63	9,18	98,55	-17,34	120,22
30,00	-12,47	-33,41	-46,00	19,49	15,20	62,25	-22,38	145,19
31,00	-24,80	45,44	-42,45	-42,78	18,91	12,46	-16,56	167,67
32,00	-17,12	23,80	-41,43	-103,62	19,89	-32,13	-14,80	144,56
33,00	-23,20	-42,55	-40,56	-152,24	20,36	-67,68	-16,05	123,76
34,00	-19,03	-169,48	-39,68	170,39	20,77	-100,08	-18,09	107,73
35,00	-12,46	150,31	-38,71	143,10	20,98	-130,13	-21,69	77,58
36,00	-9,33	121,49	-37,54	123,52	21,06	-159,84	-27,59	9,57
37,00	-8,60	98,97	-36,14	104,39	20,87	172,52	-22,46	-82,68
38,00	-8,42	82,30	-34,82	83,69	20,58	146,27	-17,76	-110,30
39,00	-8,47	68,26	-33,60	64,74	20,27	121,22	-14,75	-129,22
40,00	-9,42	54,37	-32,98	45,70	19,84	95,76	-12,44	-146,78
41,00	-10,23	46,67	-32,48	26,65	19,24	72,14	-11,06	-164,32
42,00	-10,72	39,92	-32,21	11,28	18,67	50,20	-10,53	-179,35
43,00	-10,45	31,54	-31,68	-6,54	18,19	28,89	-10,41	170,06
44,00	-9,61	16,79	-31,02	-24,45	17,83	6,99	-10,02	160,92
45,00	-8,75	-4,98	-30,90	-42,39	17,42	-15,61	-9,83	151,98
46,00	-7,93	-30,22	-30,45	-61,72	17,00	-38,88	-9,17	144,58
47,00	-6,42	-61,17	-30,47	-83,47	16,37	-63,88	-8,39	134,96
48,00	-4,94	-93,19	-31,52	-107,28	15,28	-89,82	-7,55	121,85
49,00	-3,67	-122,84	-32,48	-128,35	13,83	-114,96	-6,98	108,11
50,00	-2,71	-147,44	-33,68	-147,17	12,15	-137,91	-6,69	91,01

Typical Output Power (P-1dB gain compression) Measurements (CW on wafer)

Conditions: $V_d = 3.5$ Volt, Frequency = 38 GHz.

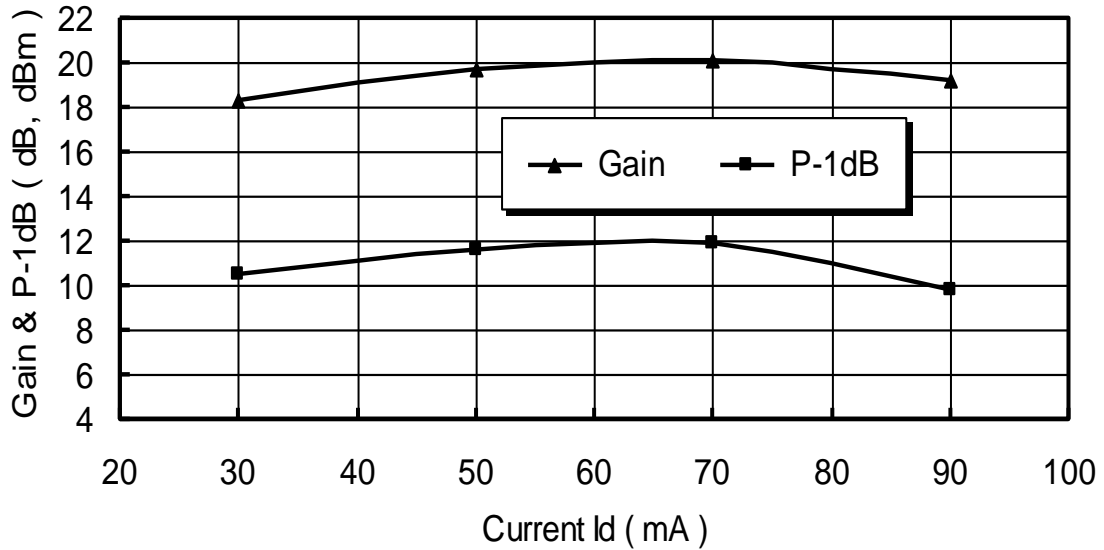

Conditions: $I_d = 60$ mA, Frequency = 38 GHz.

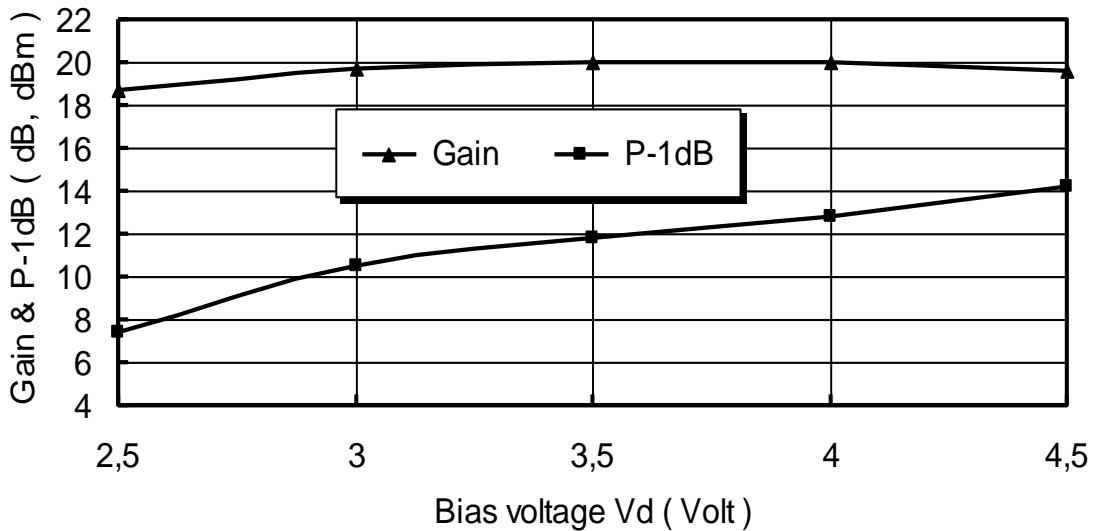

Typical S parameters Measurements (on wafer)

Bias Conditions: Vd = 3.5 Volt, Id = 60 mA

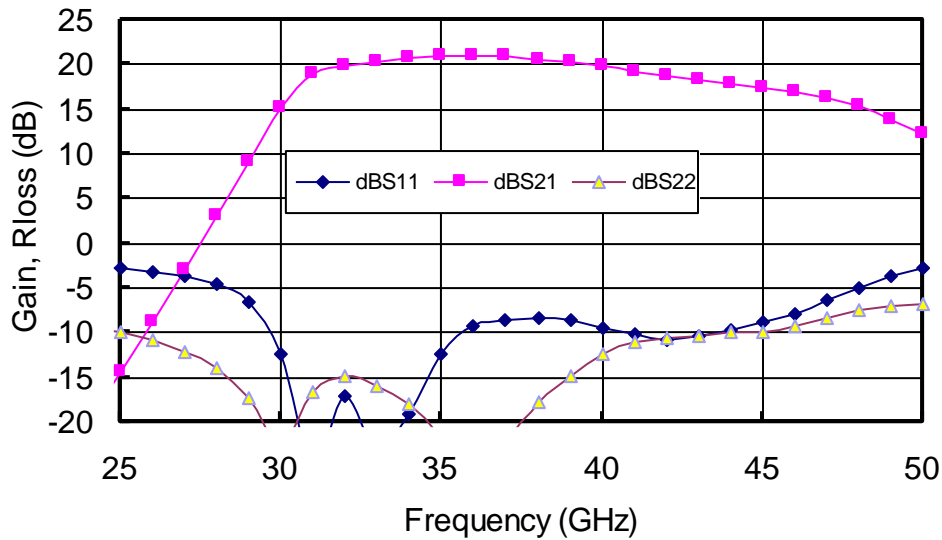

Typical Gain & NF Measurements (on wafer)

Bias Conditions: Vd = 3.5 Volt, Id = 60 mA

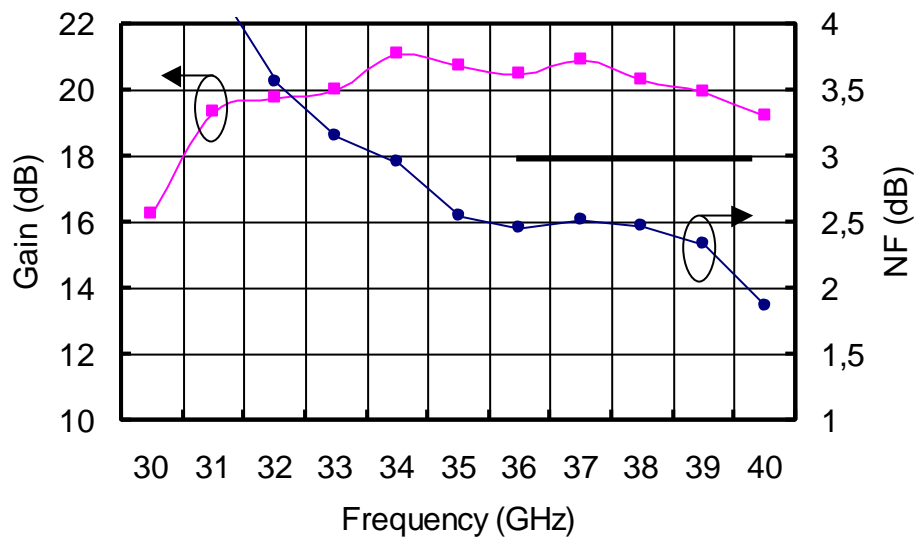

Typical Bias Tuning for Low Noise Operation

The circuit schematic is given below:

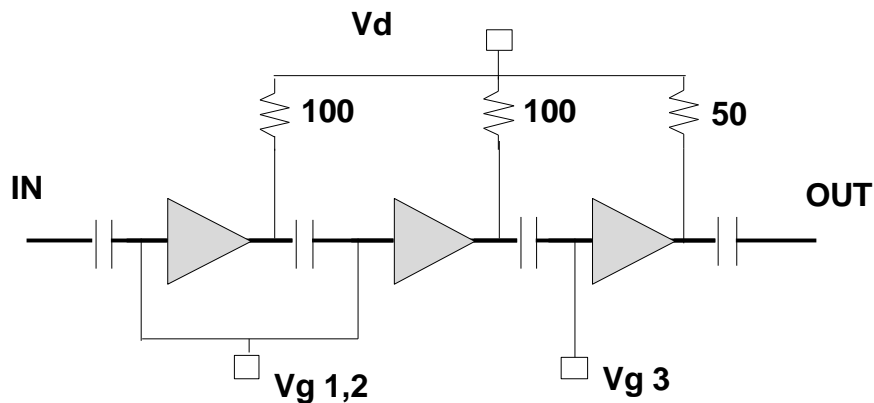

For low noise operation, a separate access to the gate voltages of the two first stages ($V_{gs1\&2}$), and of the output stage (V_{gs3}) is provided.

Nominal bias for low noise operation is obtained for a typical current of 20 mA for the output stage and 15 mA for each of the two first stages (50 mA for the amplifier).

The first step to bias the amplifier is to tune the $V_{gs1\&2} = -1V$, and V_{gs3} to drive 20 mA for the full amplifier.

Then $V_{gs1\&2}$ is reduced to obtain 50 mA of current through the amplifier.

A fine tuning of the noise figure may be obtained by modifying the $V_{gs1\&2}$ bias voltage, but keeping the previous value for V_{gs3} .

Chip Assembly and Mechanical Data

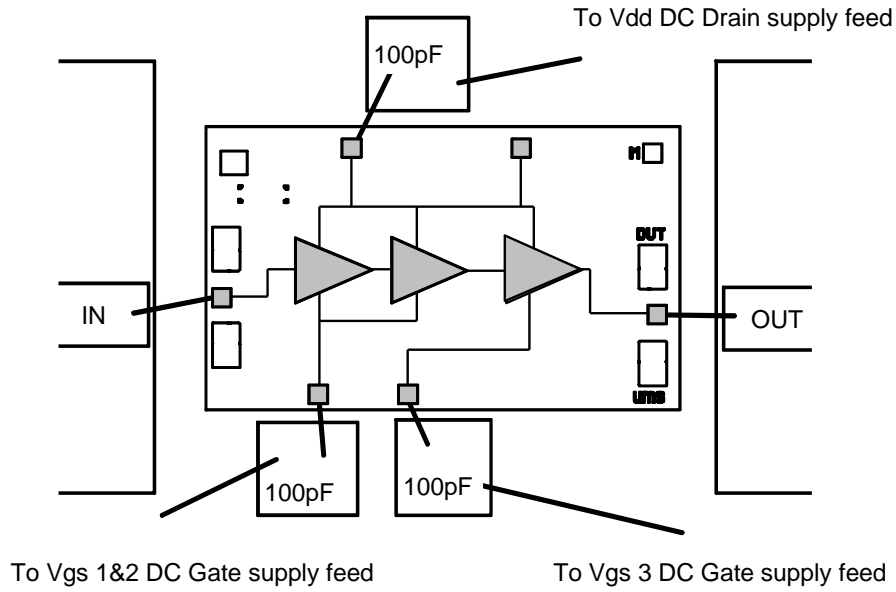

Note : Supply feed should be capacitively bypassed.

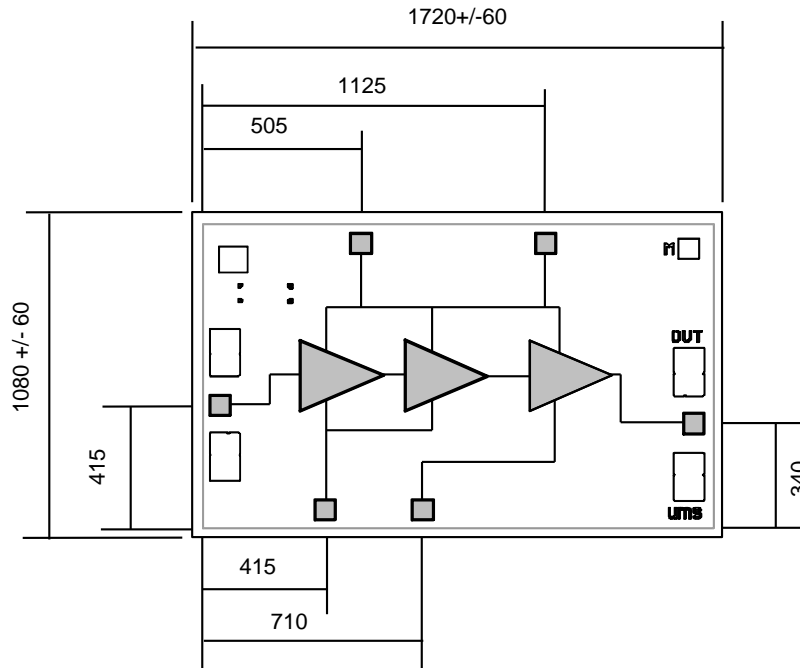

Bonding pad positions.

(Chip thickness: 100µm. All dimensions are in micrometers)

Ordering Information

Chip form : CHA2394-99F/00

Information furnished is believed to be accurate and reliable. However **United Monolithic Semiconductors S.A.S.** assumes no responsibility for the consequences of use of such information nor for any infringement of patents or other rights of third parties which may result from its use. No license is granted by implication or otherwise under any patent or patent rights of **United Monolithic Semiconductors S.A.S.**. Specifications mentioned in this publication are subject to change without notice. This publication supersedes and replaces all information previously supplied. **United Monolithic Semiconductors S.A.S.** products are not authorised for use as critical components in life support devices or systems without express written approval from **United Monolithic Semiconductors S.A.S.**