

2-4GHz Driver

GaAs Monolithic Microwave IC in SMD leadless package

Description

The CHA4105-QDG is a monolithic two-stage driver amplifier delivering 24dBm output power @ 1dB gain compression in the range 2-4GHz.

It is designed for a wide range of applications, from military to commercial communication systems.

The circuit is manufactured with a pHEMT process, 0.25 μ m gate length, via holes through the substrate, air bridges and electron beam gate lithography.

It is supplied in RoHS compliant SMD package.

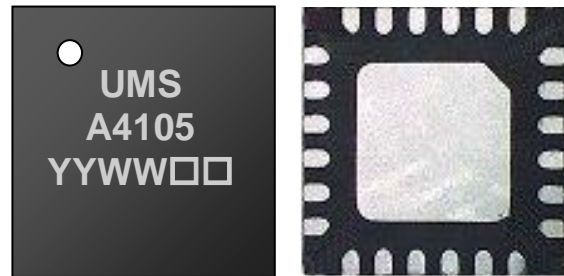

Main Features

- Broadband performances: 2-4GHz
- 24dBm @ 1dB gain compression
- 23dB Gain
- DC bias: V+ = 5V ; V- = -5V
- DC power consumption: 180mA
- QFN4x4

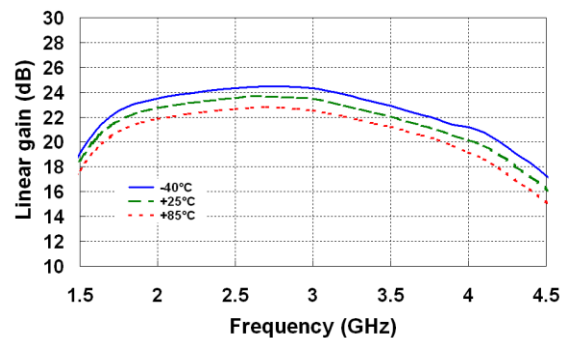

Main Characteristics

Tamb.= +25°C

Symbol	Parameter	Min	Typ	Max	Unit
Freq	Frequency range	2		4	GHz
Gain	Linear Gain		23		dB
Pout	Output Power @1dB comp.		24		dBm

Main Characteristics

Tamb.= +25°C

Symbol	Parameter	Min	Typ	Max	Unit
Freq	Frequency range	2		4	GHz
Gain	Linear Gain		23		dB
RL_in	Input Return Loss		15		dB
RL_out	Output Return Loss		18		dB
P_1dB	Output power @ 1dB gain compression		24		dBm
PAE_1dB	Power Added Efficiency @ 1dBcomp.		28		%
NF	Noise Figure		5		dB
V+	Positive supply voltage		5		V
V-	Negative supply voltage		-5		V
I+	Positive supply quiescent current ⁽¹⁾		180		mA
I-	Negative supply quiescent current		5		mA
I+_1dB	Positive current @ 1dB gain compression		220		mA

These values are representative of onboard measurements as defined on the drawing in paragraph "Evaluation mother board".

⁽¹⁾ Parameter can be adjusted by tuning of V-.

Absolute Maximum Ratings ⁽¹⁾

Tamb.= +25°C

Symbol	Parameter	Values	Unit
V+	Positive supply voltage	6.5V	V
I+	Positive supply quiescent current	240	mA
V-	Negative supply voltage	-3.75	V
Tj	Junction temperature ⁽²⁾	175	°C
Cmp	Compression level	6	dB
I+_sat	Supply current in saturation	320	mA
Ta	Operating temperature range	-40 to +85	°C
Tstg	Storage temperature range	-55 to +150	°C

⁽¹⁾ Operation of this device above anyone of these parameters may cause permanent damage.

⁽²⁾ Thermal Resistance channel to ground paddle: 65°C/W for Tamb. = +83°C with 5V & 180mA.

Device thermal performances

All the figures given in this section are obtained assuming that the QFN device is cooled down only by conduction through the package thermal pad (no convection mode considered). The temperature is monitored at the package back-side interface (Tcase) as shown below. The system maximum temperature must be adjusted in order to guarantee that Tcase remains below than the maximum value specified in the next table. So, the system PCB must be designed to comply with this requirement.

A derating must be applied on the dissipated power if the Tcase temperature can not be maintained below than the maximum temperature specified (see the curve Pdiss. Max) in order to guarantee the nominal device life time (MTTF).

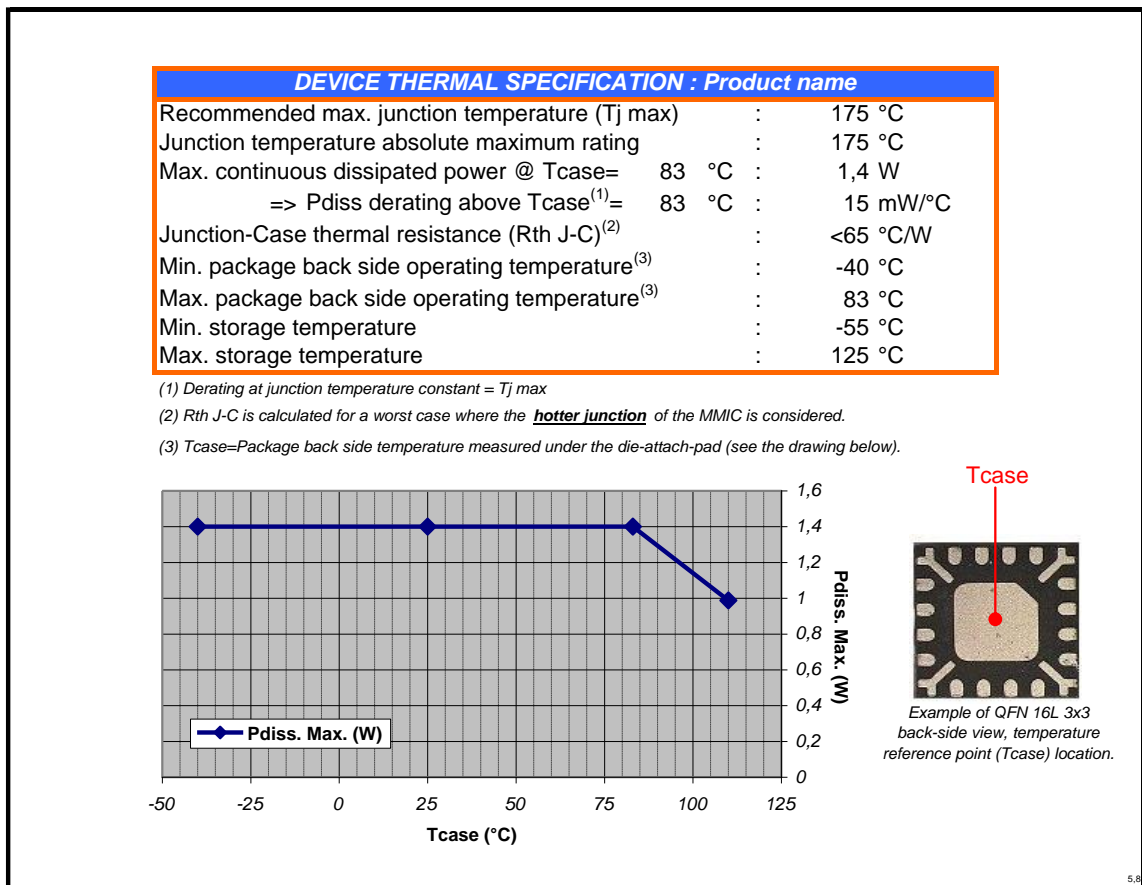

Typical Board Measurements

V+ = +5V, V- = -5V, I+ = 180mA, I- = 2mA

Linear Gain

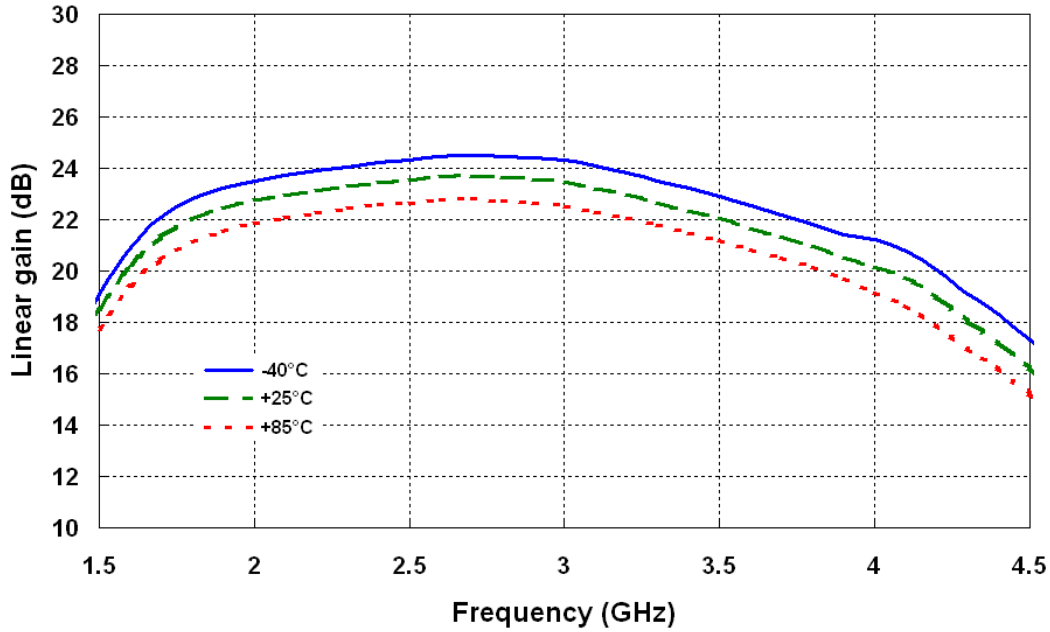

In/out Return Loss

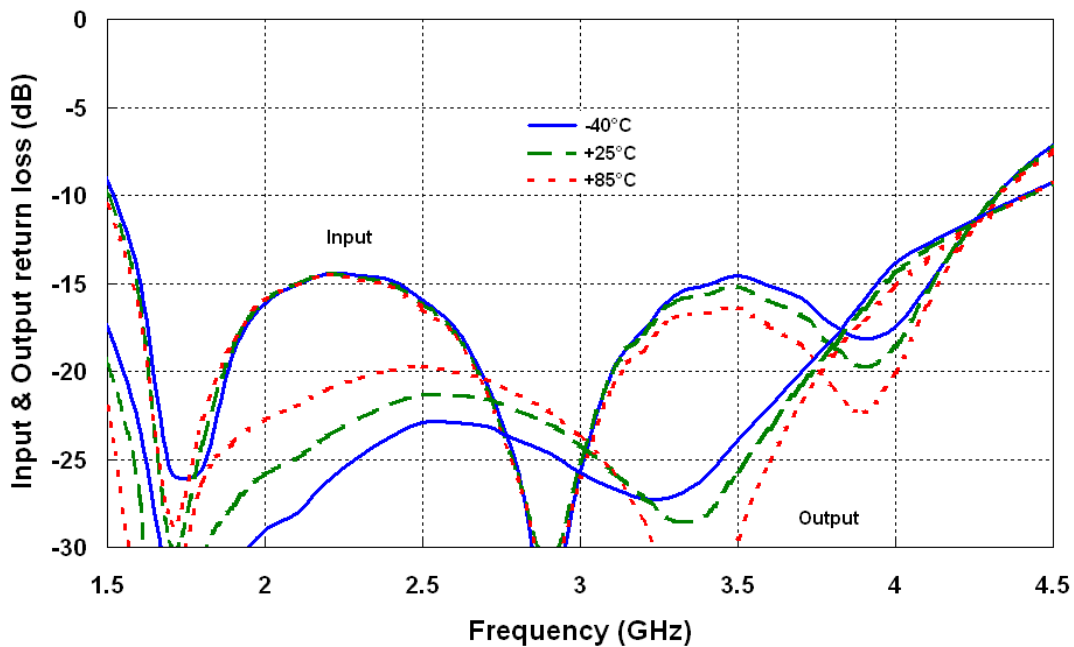

Typical Board Measurements

V+ = +5V, V- = -5V, I+ = 180mA, I- = 2mA

Output power @ 1dB gain compression versus Frequency & Temperature

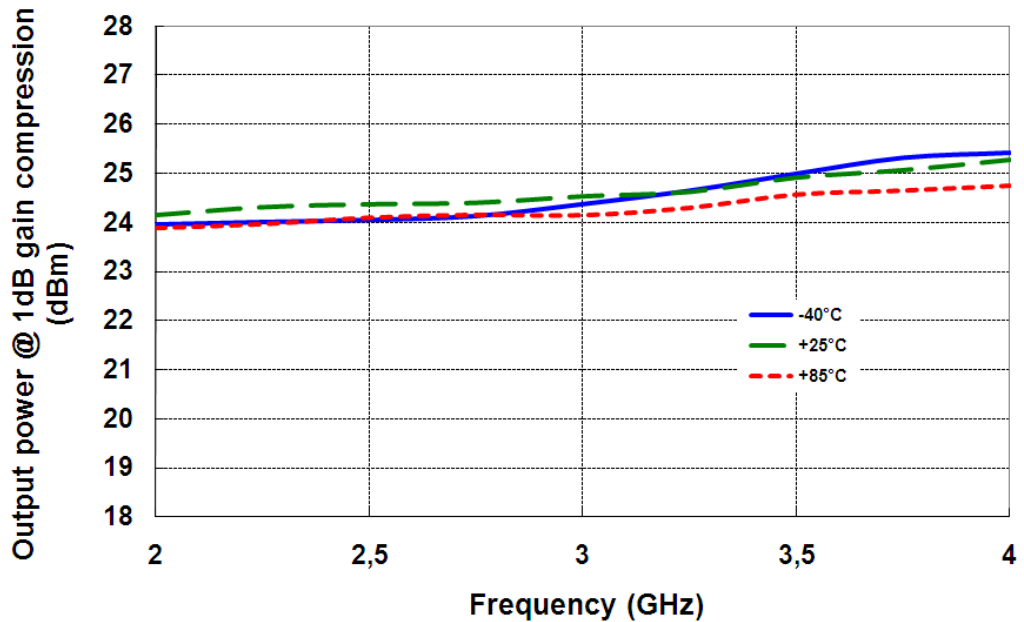

Positive supply current @ 1dB gain compression versus Frequency & Temperature

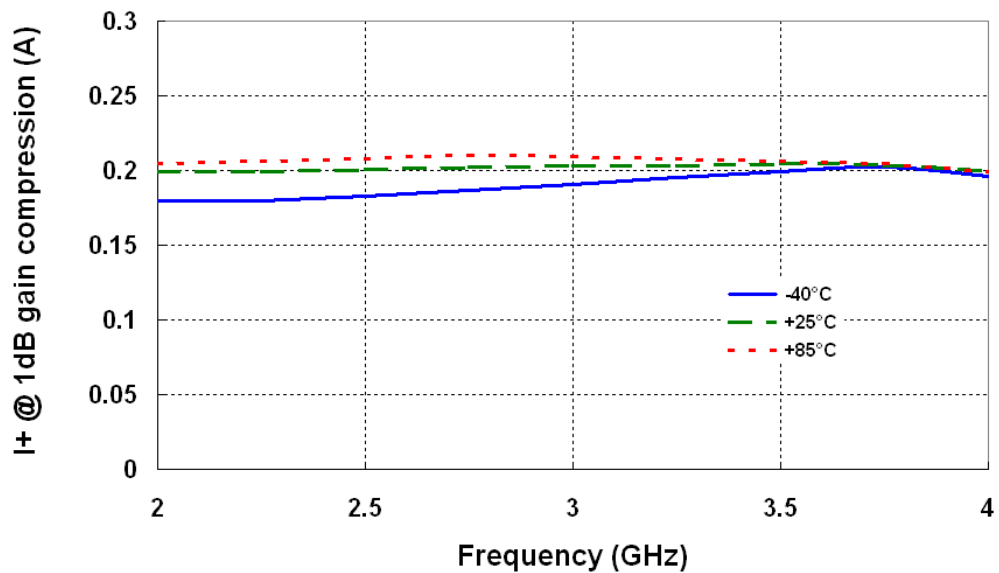

Typical Board Measurements

V+ = +5V, V- = -5V, I+ = 180mA, I- = 2mA

Output power @ saturation versus Frequency & Temperature

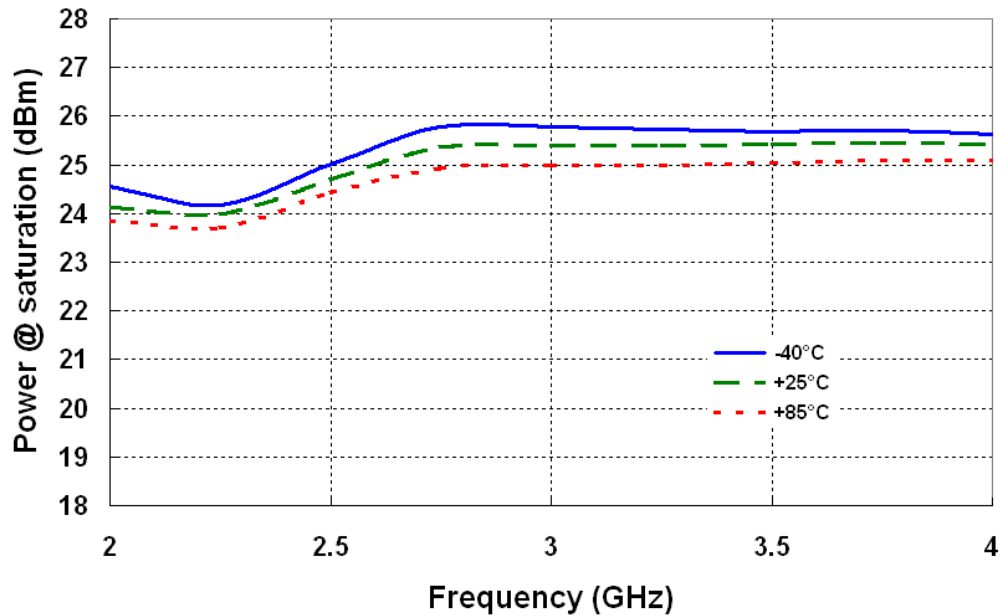

Positive supply current @ saturation versus Frequency & Temperature

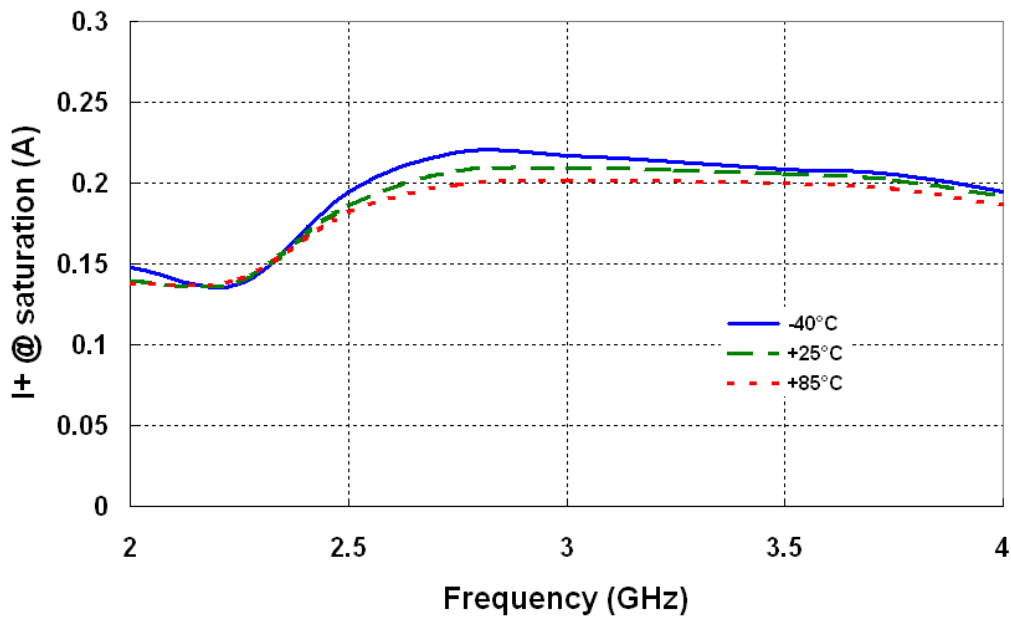

Typical Board Measurements

V+ = +5V, V- = -5V, I+ = 180mA, I- = 2mA

Power Added Efficiency (PAE) @ 1dB gain compression versus Frequency & Temperature

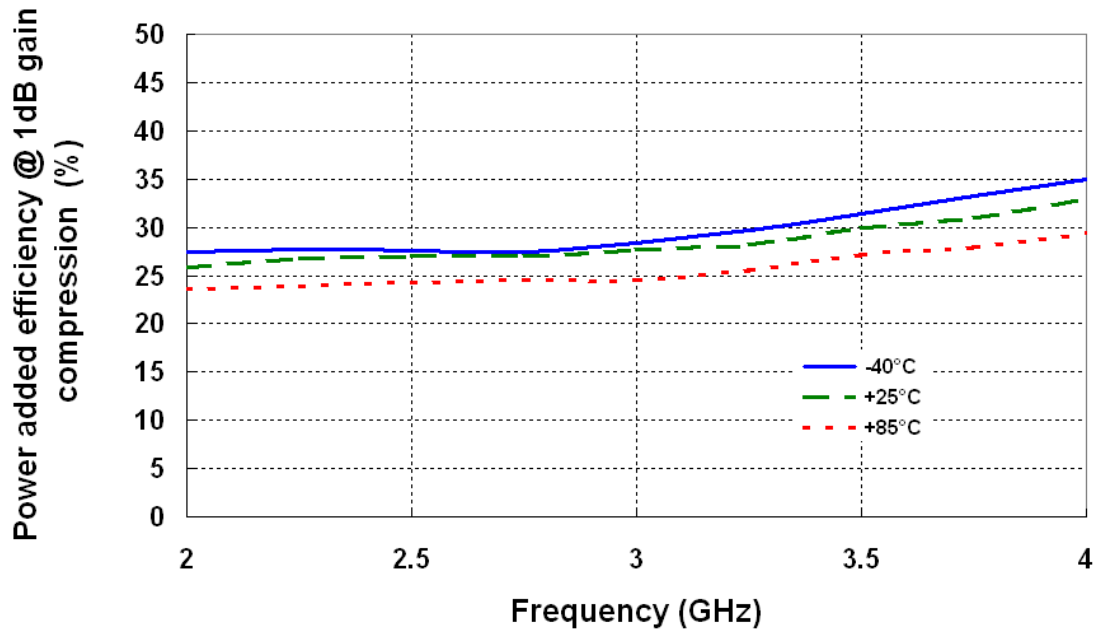

Noise Figure versus Frequency & Temperature

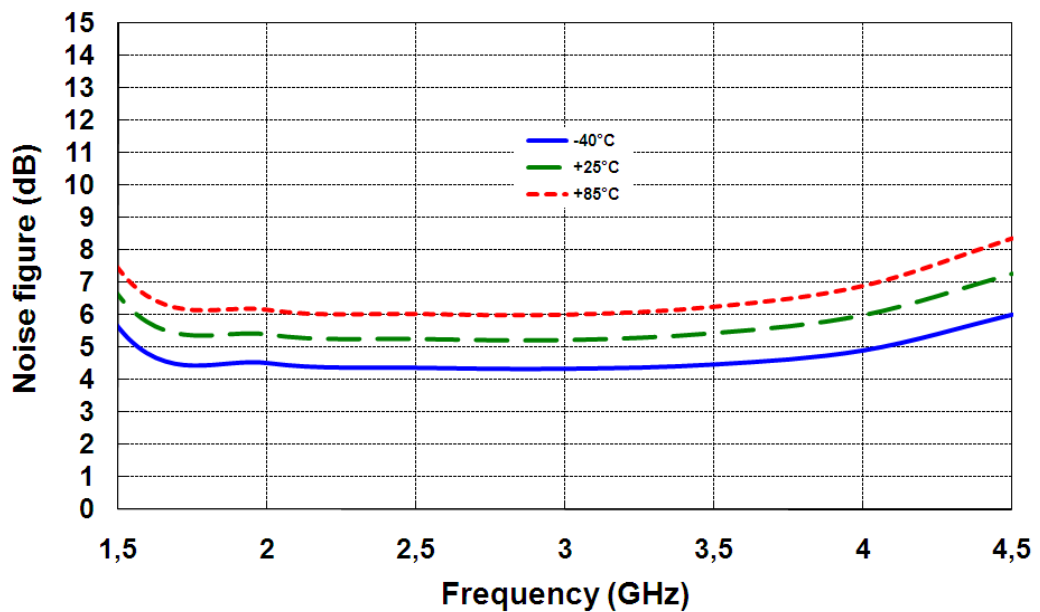

Package outline (1)

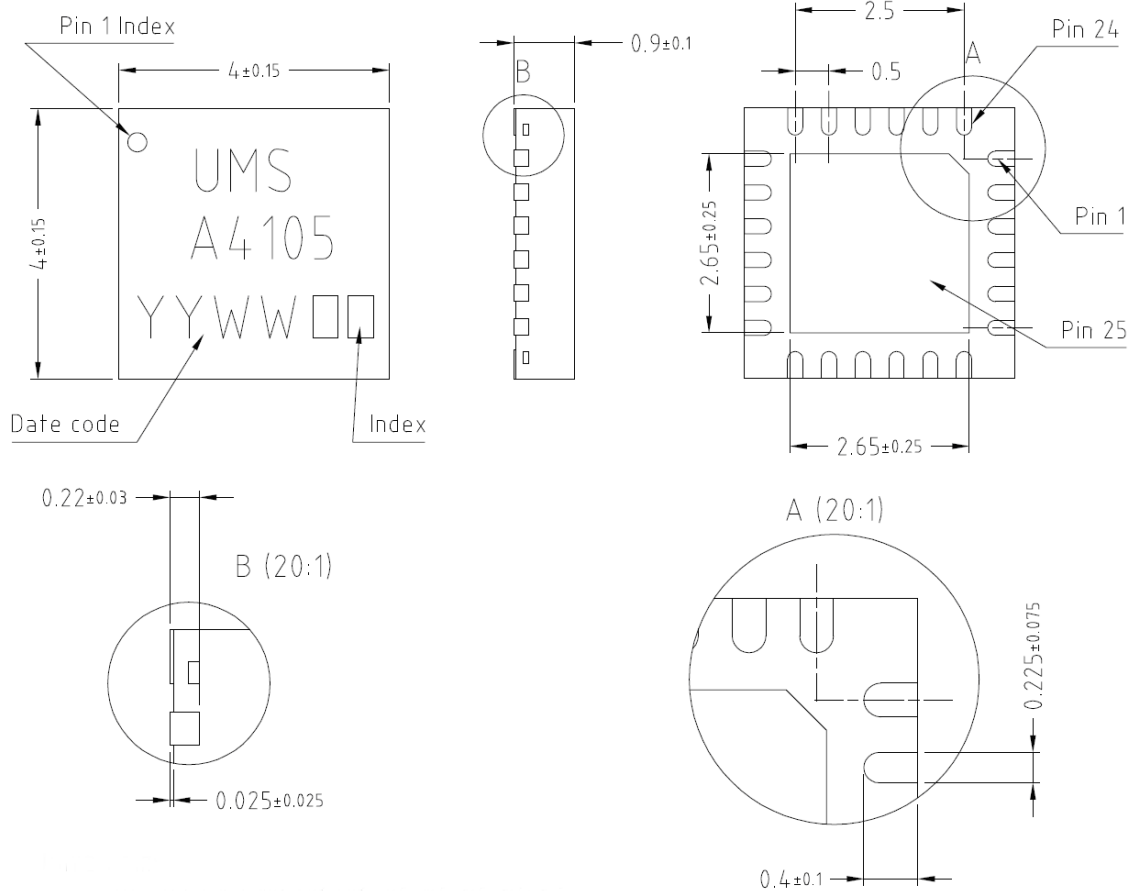

Matt tin. Lead Free	(Green)	1-	Nc	11-	Nc	21-	V+
Units :	mm	2-	Nc	12-	Nc	22-	Nc
From the standard :	JEDEC MO-220 (VGGD)	3-	Nc	13-	Nc	23-	V-
		4-	RF in	14-	Nc	24-	Nc
25-	GND	5-	Nc	15-	RF out		
		6-	Nc	16-	Nc		
		7-	Nc	17-	Nc		
		8-	Nc	18-	Nc		
		9-	Gnd ⁽²⁾	19-	Nc		
		10-	Nc	20-	Gnd ⁽²⁾		

(1) The package outline drawing included to this data-sheet is given for indication. Refer to the application note AN0017 (<https://www.ums-rf.com>) for exact package dimensions.

(2) It is strongly recommended to ground all pins marked "Gnd" through the PCB board. Ensure that the PCB board is designed to provide the best possible ground to the package.

Evaluation mother board

- Compatible with the proposed footprint.
- Based on typically Ro4003 / 8mils or equivalent.
- Using a micro-strip to coplanar transition to access the package.
- Recommended for the implementation of this product on a module board.
- Decoupling capacitors of 10nF \pm 10% are recommended for all DC accesses.
- See application note AN0017 for details.

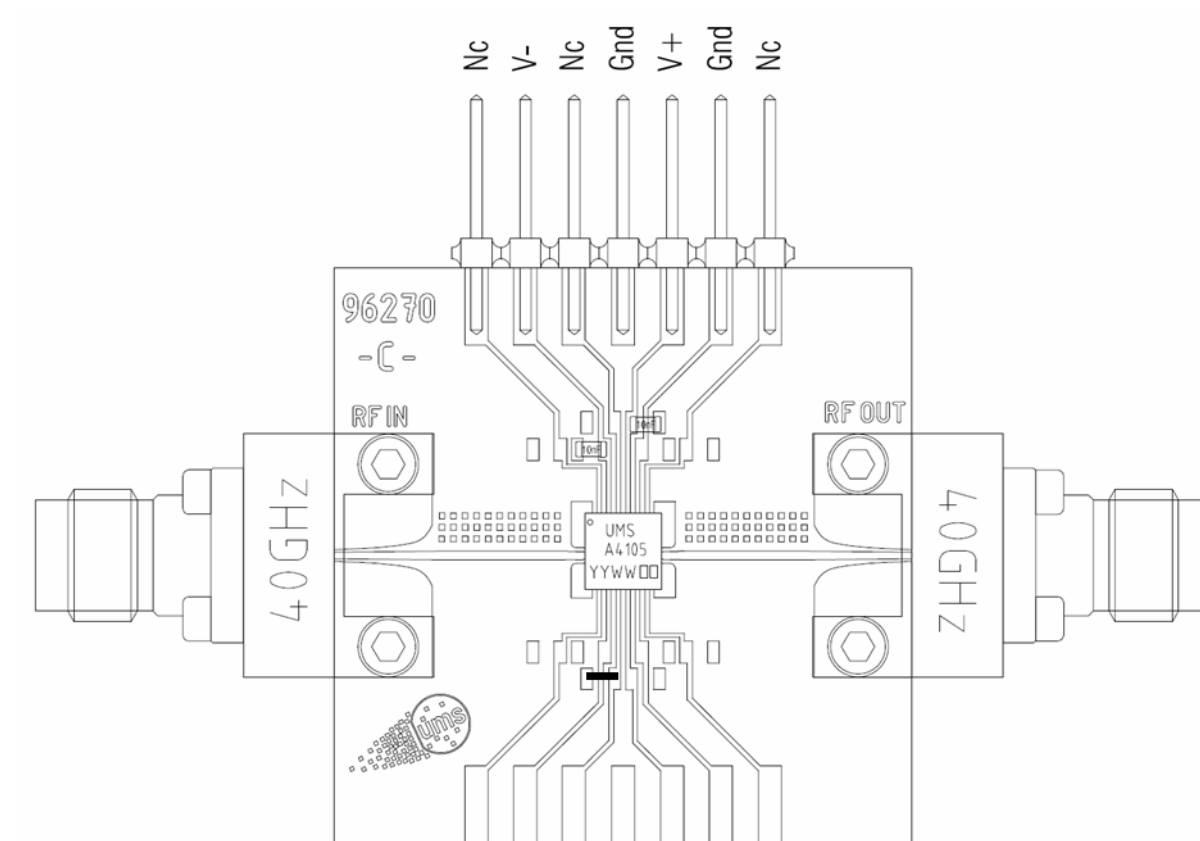

DC Schematic

Driver : 5V, 180mA

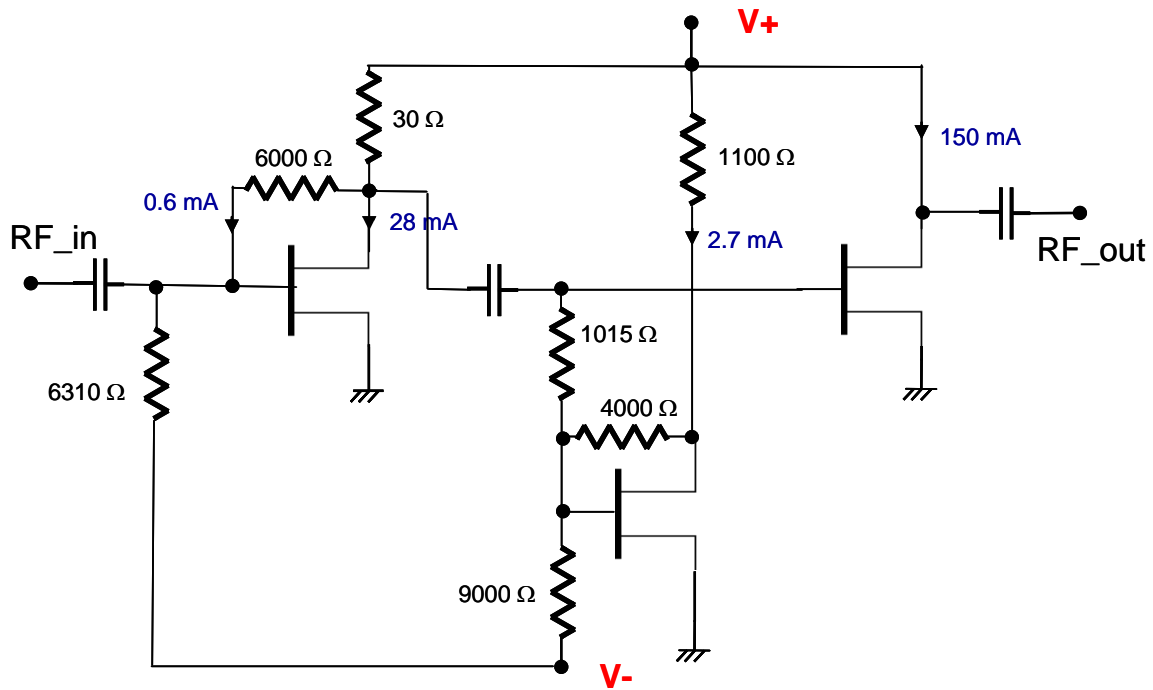

Notes



Recommended package footprint

Refer to the application note AN0017 available at <https://www.ums-rf.com> for package footprint recommendations.

SMD mounting procedure

For the mounting process standard techniques involving solder paste and a suitable reflow process can be used. For further details, see application note AN0017.

Recommended environmental management

Refer to the application note AN0019 available at <https://www.ums-rf.com> for environmental data on UMS package products.

Recommended ESD management

Refer to the application note AN0020 available at <https://www.ums-rf.com> for ESD sensitivity and handling recommendations for the UMS package products.

Ordering Information

QFN 4x4 RoHS compliant package:	CHA4105-QDG/XY	
	Stick: XY = 20	Tape & reel: XY = 21

Information furnished is believed to be accurate and reliable. However **United Monolithic Semiconductors S.A.S.** assumes no responsibility for the consequences of use of such information nor for any infringement of patents or other rights of third parties which may result from its use. No license is granted by implication or otherwise under any patent or patent rights of **United Monolithic Semiconductors S.A.S.**. Specifications mentioned in this publication are subject to change without notice. This publication supersedes and replaces all information previously supplied. **United Monolithic Semiconductors S.A.S.** products are not authorised for use as critical components in life support devices or systems without express written approval from **United Monolithic Semiconductors S.A.S.**