

## 17 - 24GHz Medium Power Amplifier

### GaAs Monolithic Microwave IC

#### Description

The CHA4253aQQG is a four stage monolithic Medium Power Amplifier. It is designed for a wide range of applications, from military to commercial communication systems. The circuit is manufactured with a pHEMT process, 0.15µm gate length. It is supplied in RoHS compliant SMD package.



#### Main Features

- Broadband performances: 17- 24GHz
- 24dBm Pout for 1dB gain compression
- 23dB gain
- 33dBm OTOI
- DC bias: Vd= 4.0V, Id= 230mA
- 16L-QFN4x4 (QQG)
- MSL1

Output power & PAE versus Frequency

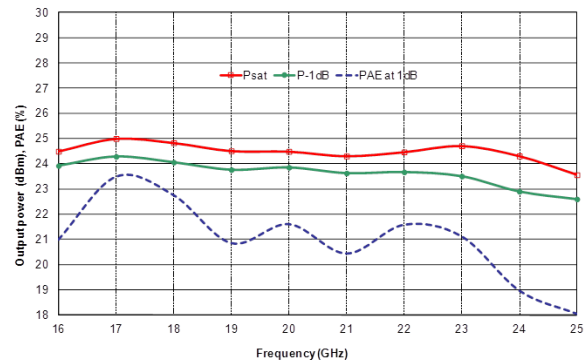

#### Main Electrical Characteristics

Tamb.= +25°C

Symbol	Parameter	Min	Typ	Max	Unit
Freq	Frequency range	17.0		24.0	GHz
Gain	Linear Gain	21	23	26	dB
P-1dB	Output Power @1dB comp.	22.5	24	25.5	dBm
OTOI	3 <sup>rd</sup> order Intercept point	31	33	35	dBm

## Electrical Characteristics

Tamb.= +25°C, Vd = +4.0V

Symbol	Parameter	Min	Typ	Max	Unit
Freq	Frequency range	17.0		24.0	GHz
Gain	Linear Gain	21	23	26	dB
$\Delta G$	Gain variation in temperature		-0.04		dB/°C
OTOI	3 <sup>rd</sup> order Intercept point	31	33	35	dBm
P <sub>-1dB</sub>	Output power @ 1dB compression	22.5	24	25.5	dBm
Psat	Saturated Output Power	23	24.5	26	dBm
RLin	Input Return Loss		12		dB
RLout	Output Return Loss		15		dB
NF	Noise figure		7.5		dB
Id	Quiescent Drain current		230		mA
Vg	Gate voltage		-0.7		V

These values are representative of onboard measurements as defined on the drawing in paragraph "Evaluation board".

## Absolute Maximum Ratings <sup>(1)</sup>

Tamb.= +25°C

Symbol	Parameter	Values	Unit
Vd	Drain bias voltage	6V	V
Id	Drain bias quiescent current	370	mA
Vg	Gate bias voltage	-2 to +0.4	V
Vdg	External drain-gate excursion	12	V
Pin	Maximum input power	10	dBm
Tj	Junction temperature <sup>(2)</sup>	175	°C
Ta	Operating temperature range	-40 to +95	°C
Tstg	Storage temperature range	-55 to +150	°C

<sup>(1)</sup> Operation of this device above any one of these parameters may cause permanent damage.

<sup>(2)</sup> Duration < 1s.

## Typical Bias Conditions

Tamb.= +25°C

Symbol	Pad N°	Parameter	Values	Unit
Vd12	6	DC Drain voltage 1 <sup>st</sup> , 2 <sup>nd</sup> stage	4	V
Vd34	7	DC Drain voltage 3 <sup>rd</sup> , 4 <sup>th</sup> stage	4	V
Vg12	16	DC Gate voltage 1 <sup>st</sup> & 2 <sup>nd</sup> stage	-0.7	V
Vg34	14	DC Gate voltage 3 <sup>rd</sup> & 4 <sup>th</sup> stage	-0.7	V

**Device thermal performances**

All the figures given in this section are obtained assuming that the QFN device is only cooled down by conduction through the package thermal pad (no convection mode considered).

The temperature is monitored at the package back-side interface (Tcase).

The system maximum temperature must be adjusted in order to guarantee that Tjunction remains below the maximum value specified in the Absolute Maximum Ratings table.

So, the system PCB must be designed to comply with this requirement.

Parameter	Biasing conditions	Tjunction (°C)	RTH (°C/W)	T50 (hours)
RTH <sup>(1)</sup> Thermal Resistance ( Junction to Case)	Vd = 4V Id = 230mA Pdiss = 0.92W	114.3	31.9	3.04E+10

<sup>(1)</sup> Assuming 85°C Tcase

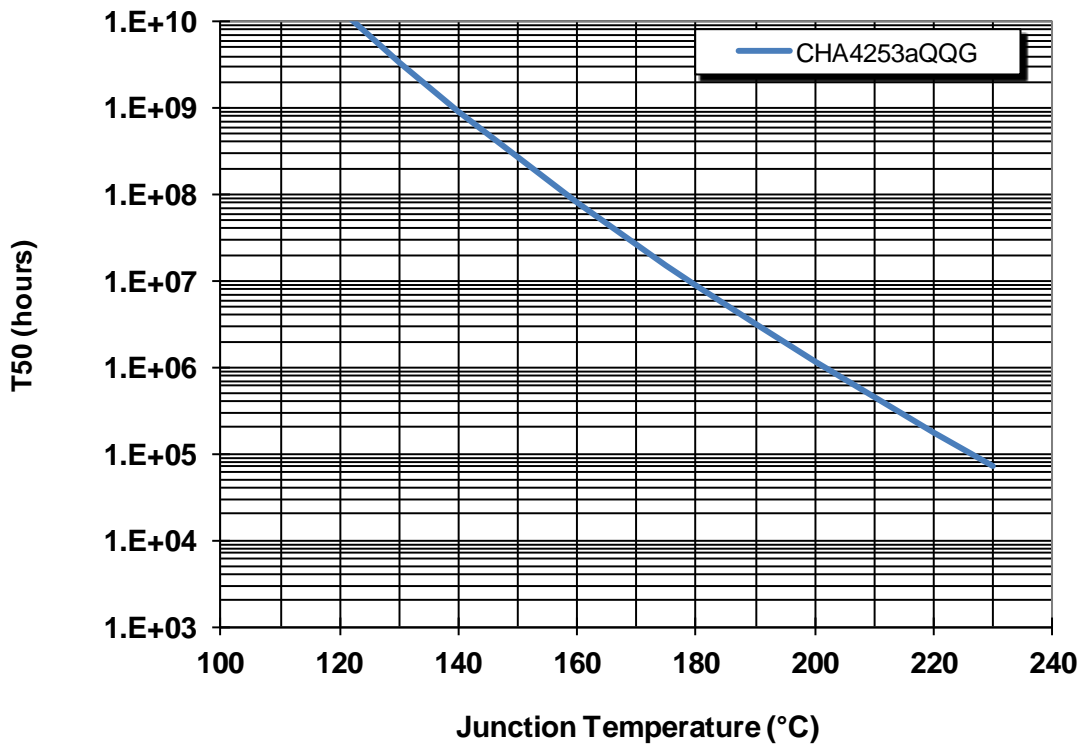

## Typical Package Sij parameters

Tamb.= +25°C, Vd = +4.0V, Id = 230mA

Freq (GHz)	S11 (dB)	PhS11 (°)	S12 (dB)	PhS12 (°)	S21 (dB)	PhS21 (°)	S22 (dB)	PhS22 (°)
2	-0.730	123.2	-63.711	-6.2	-69.063	-19.0	-0.761	122.7
2.5	-0.818	108.9	-60.605	32.4	-62.846	45.7	-0.824	107.8
3	-0.889	93.9	-80.897	-91.2	-63.457	-101.8	-0.871	92.9
3.5	-0.991	78.5	-60.653	0.0	-63.035	0.0	-0.926	76.8
4	-1.122	62.7	-82.251	151.3	-71.708	12.1	-1.013	60.6
4.5	-1.313	46.1	-71.038	17.2	-64.931	159.5	-1.105	43.5
5	-1.612	29.2	-67.796	-42.8	-55.944	-159.0	-1.178	25.6
5.5	-2.064	13.5	-84.782	-143.9	-37.521	105.8	-1.258	7.0
6	-2.252	-2.3	-71.634	179.9	-29.698	13.5	-1.365	-13.0
6.5	-2.374	-18.8	-86.383	9.9	-25.728	-54.4	-1.466	-34.4
7	-2.411	-35.5	-76.642	85.1	-22.287	-108.9	-1.587	-56.4
7.5	-2.553	-53.4	-65.973	16.6	-19.062	-156.7	-1.689	-79.6
8	-2.807	-73.4	-57.797	-35.6	-15.918	156.3	-1.895	-105.8
8.5	-3.106	-92.5	-61.487	-72.0	-13.083	112.8	-2.119	-131.9
9	-3.437	-111.1	-58.268	-112.3	-10.411	70.6	-2.569	-158.7
9.5	-3.744	-129.8	-53.604	-159.7	-7.919	30.1	-3.050	175.5
10	-4.119	-148.9	-52.704	154.8	-5.729	-9.6	-3.768	150.1
10.5	-4.624	-167.6	-51.720	128.3	-3.607	-47.9	-4.610	124.2
11	-5.000	174.6	-51.281	98.9	-1.635	-84.6	-5.691	99.1
11.5	-5.412	155.5	-51.977	85.1	0.380	-120.5	-6.935	75.3
12	-6.006	137.4	-52.427	71.2	2.321	-155.2	-8.434	51.2
12.5	-6.561	119.3	-54.460	58.2	4.409	170.5	-10.254	27.7
13	-7.192	101.3	-52.056	58.2	6.459	136.3	-12.708	5.0
13.5	-7.821	83.3	-51.474	52.7	8.618	102.4	-15.917	-17.6
14	-8.574	66.0	-49.641	30.7	10.961	68.3	-21.061	-41.1
14.5	-9.476	50.2	-52.379	26.7	13.479	33.2	-36.427	-69.4
15	-10.598	37.2	-49.987	19.8	16.282	-3.3	-25.516	100.2
15.5	-11.463	26.8	-50.339	10.8	19.272	-44.5	-17.628	73.8
16	-12.173	20.0	-49.840	-4.0	21.933	-90.8	-14.862	46.8
16.5	-12.377	17.9	-49.950	-14.7	23.964	-142.6	-13.179	28.7
17	-11.523	13.9	-50.695	-42.6	24.674	164.5	-11.997	5.4
17.5	-10.464	2.8	-52.234	-56.5	24.263	116.0	-12.390	-17.8
18	-10.569	-11.6	-72.354	-15.8	24.017	74.4	-14.325	-24.0
18.5	-11.713	-19.2	-57.420	33.1	23.906	32.9	-13.449	-27.4
19	-11.467	-22.2	-56.914	13.9	23.424	-6.2	-13.393	-37.2
19.5	-11.136	-28.8	-54.933	-2.0	23.237	-43.4	-14.040	-43.4
20	-10.861	-39.1	-53.015	1.5	23.489	-79.4	-13.984	-48.0
20.5	-10.972	-49.8	-52.555	7.8	23.585	-117.4	-14.192	-52.3
21	-11.122	-63.0	-52.100	-17.7	23.717	-155.5	-13.594	-56.0
21.5	-12.282	-73.8	-49.378	-12.2	23.677	166.7	-13.879	-66.0
22	-13.692	-84.9	-47.135	-18.4	23.695	129.6	-14.959	-70.5
22.5	-15.153	-87.1	-49.422	11.2	24.074	93.9	-15.768	-52.8
23	-17.851	-88.8	-44.268	-34.4	24.814	53.8	-13.893	-55.7
23.5	-19.454	-73.3	-43.006	-46.5	25.271	12.9	-12.633	-56.1
24	-18.605	-51.9	-47.877	-47.5	26.081	-32.6	-13.531	-67.6
24.5	-15.959	-40.6	-46.682	-66.3	26.115	-82.2	-12.795	-49.3
25	-11.350	-46.7	-47.170	-53.9	25.590	-134.0	-8.978	-47.8
25.5	-8.897	-63.9	-49.365	-43.8	23.981	172.9	-5.884	-61.9

### Typical Board Measurements

Tamb.= +25°C, Vd = +4.0V, Id = 230mA

These values are representative of onboard measurements as defined on the drawing in paragraph "Evaluation mother board".

Linear Gain versus Frequency in Temperature

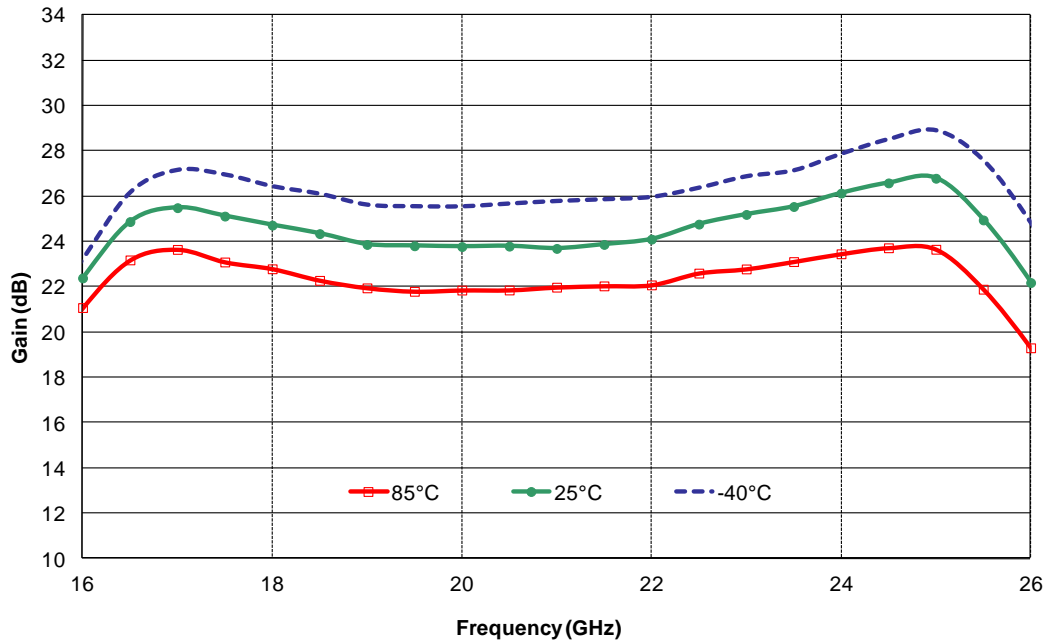

Return losses versus Frequency

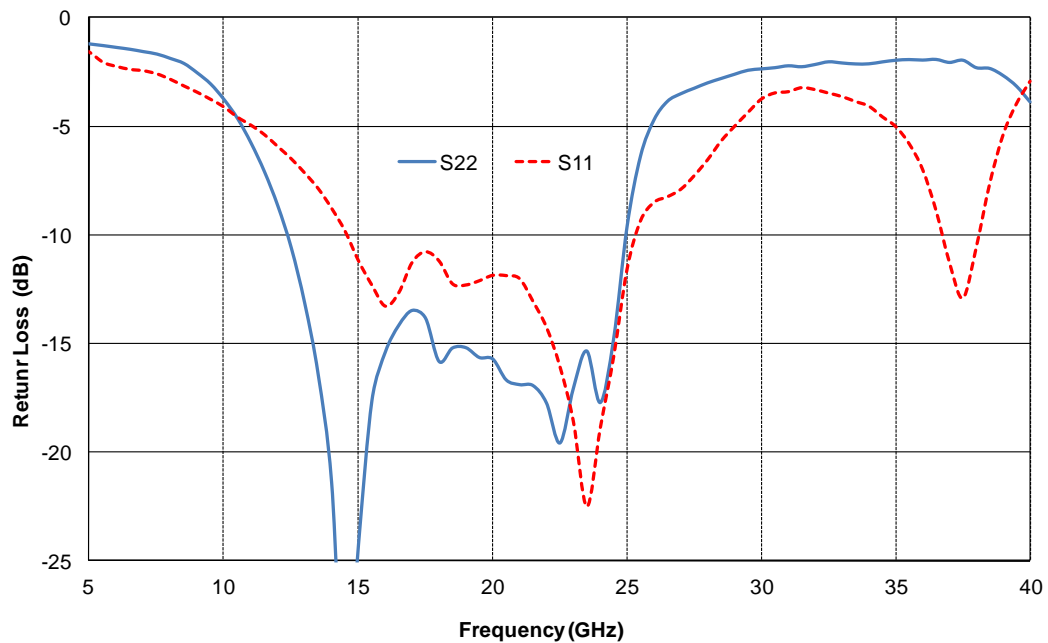

## Typical Board Measurements

Tamb.= +25°C, Vd = +4.0V, Id = 230mA

### Output power & PAE versus Frequency

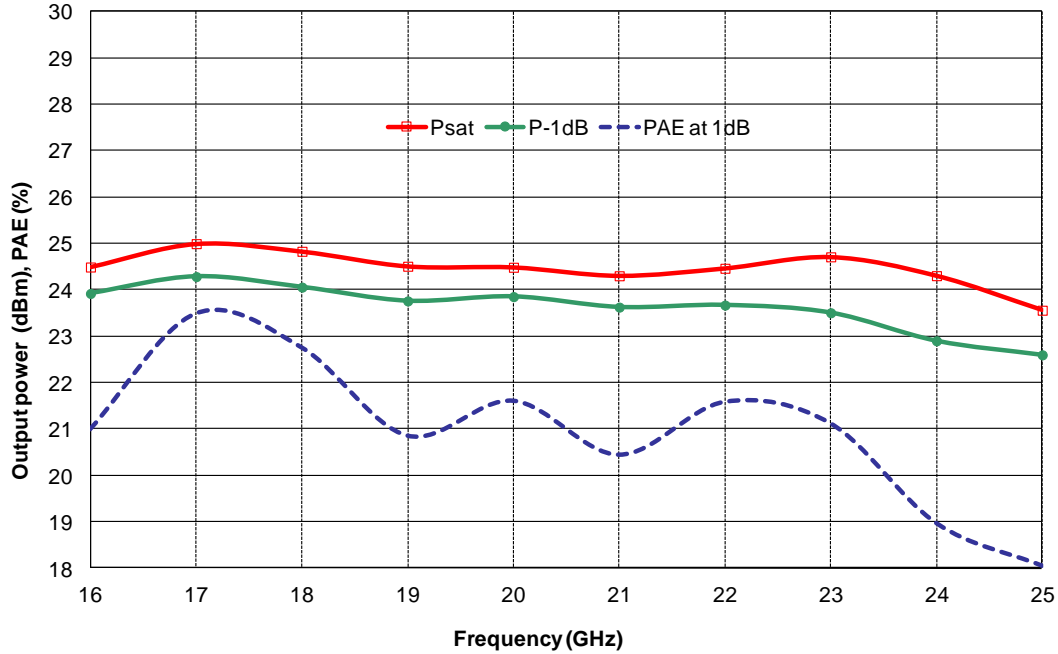

### Current versus Output Power

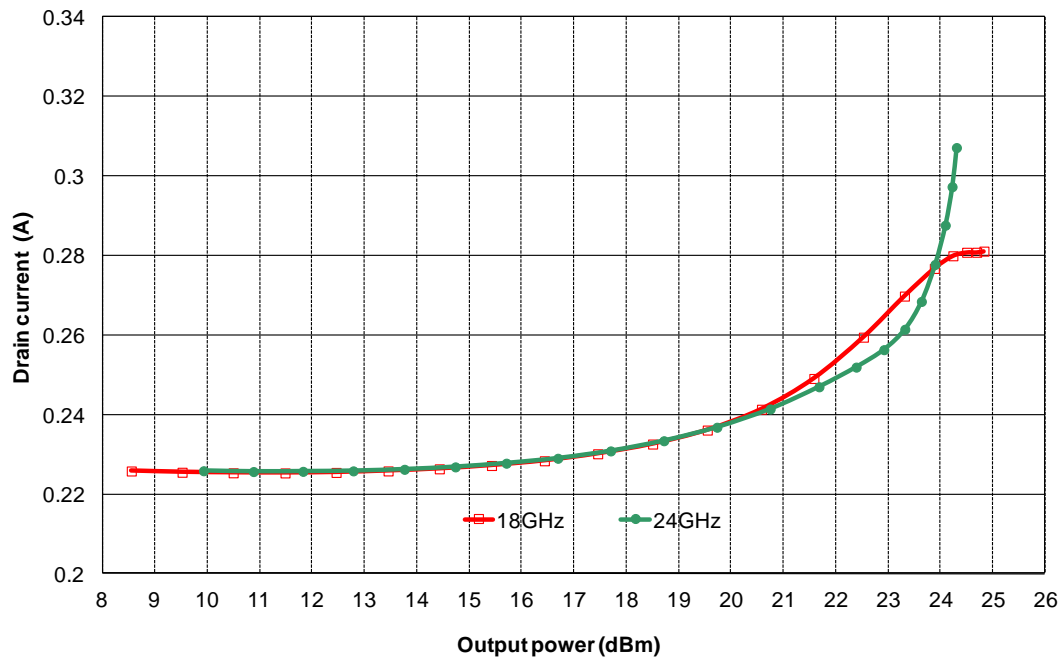

Typical Board Measurements

Tamb.= +25°C, Vd = +4.0V, Id = 230mA

Output TOI versus Output Power DCL & Frequency

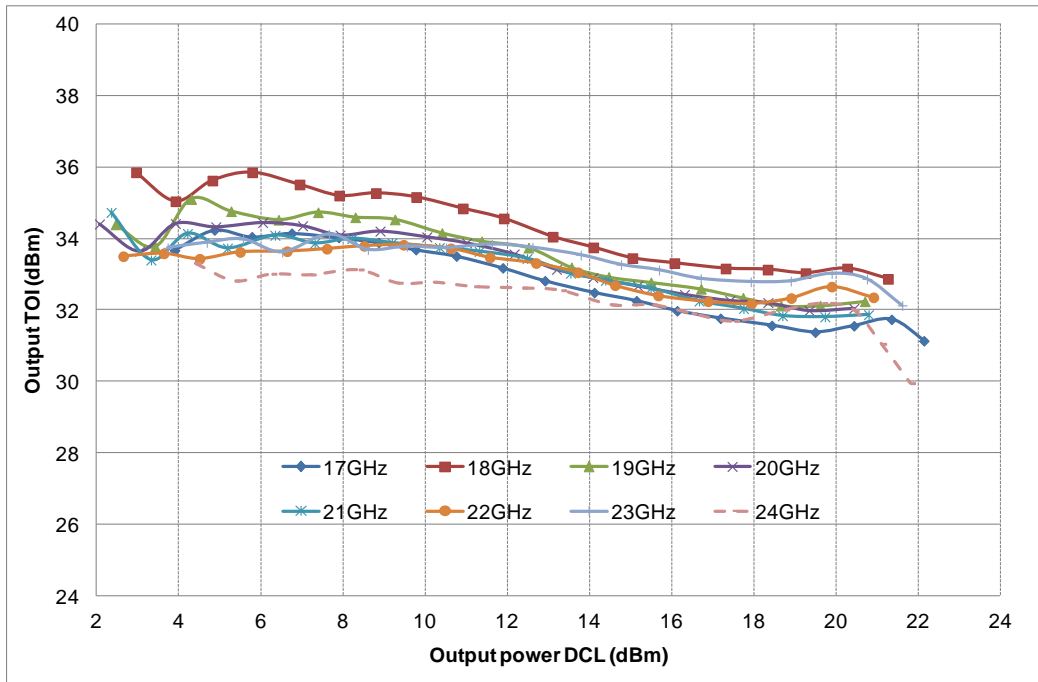

Output TOI versus Output Power DCL in Temperature at 24GHz

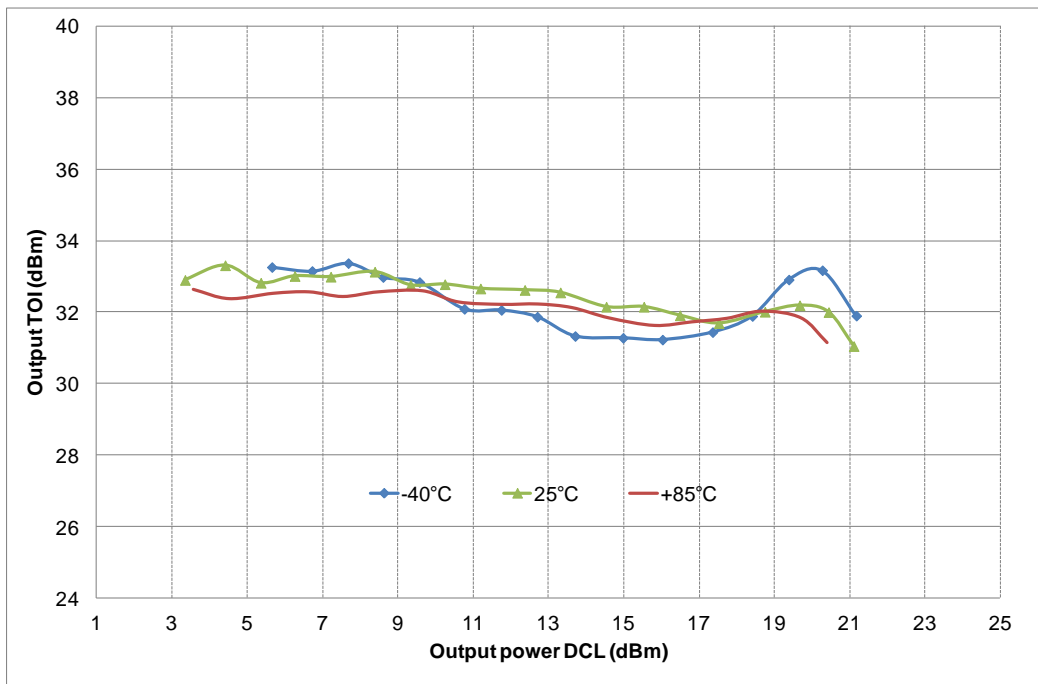

## Typical Board Measurements

Tamb.= +25°C, Vd = +4.0V, Id = 230mA

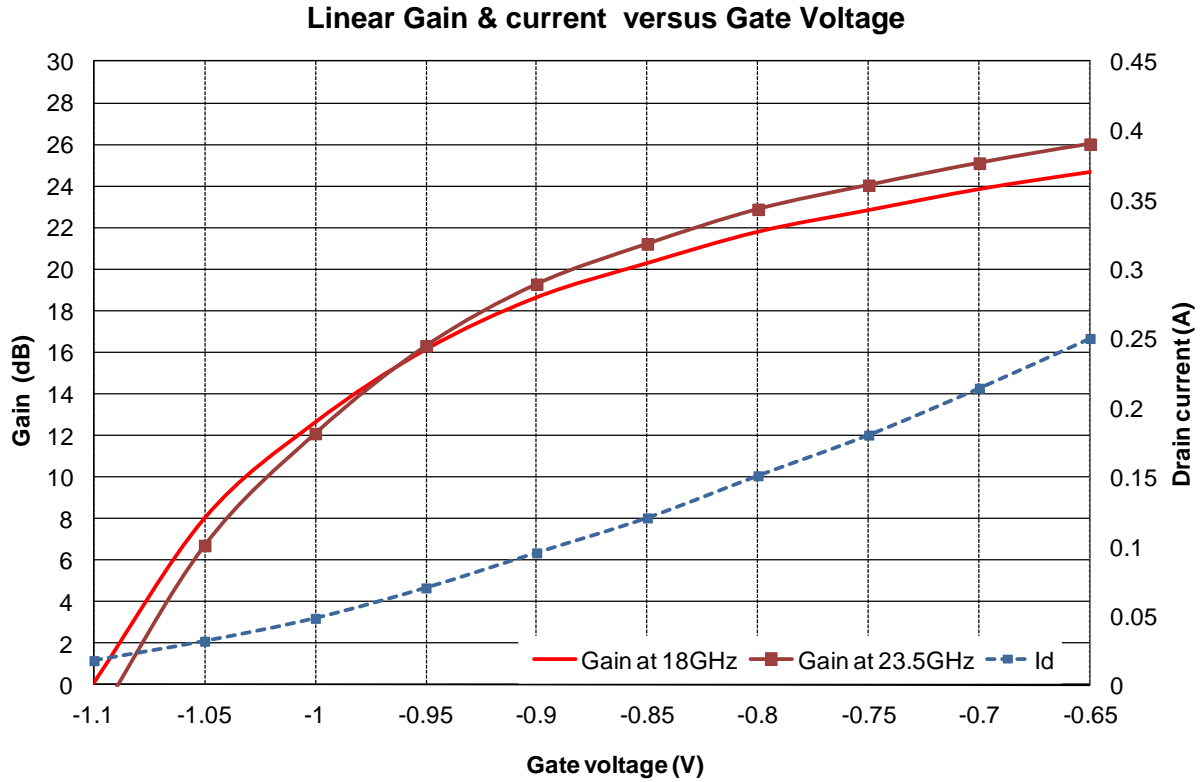



Package outline (1)

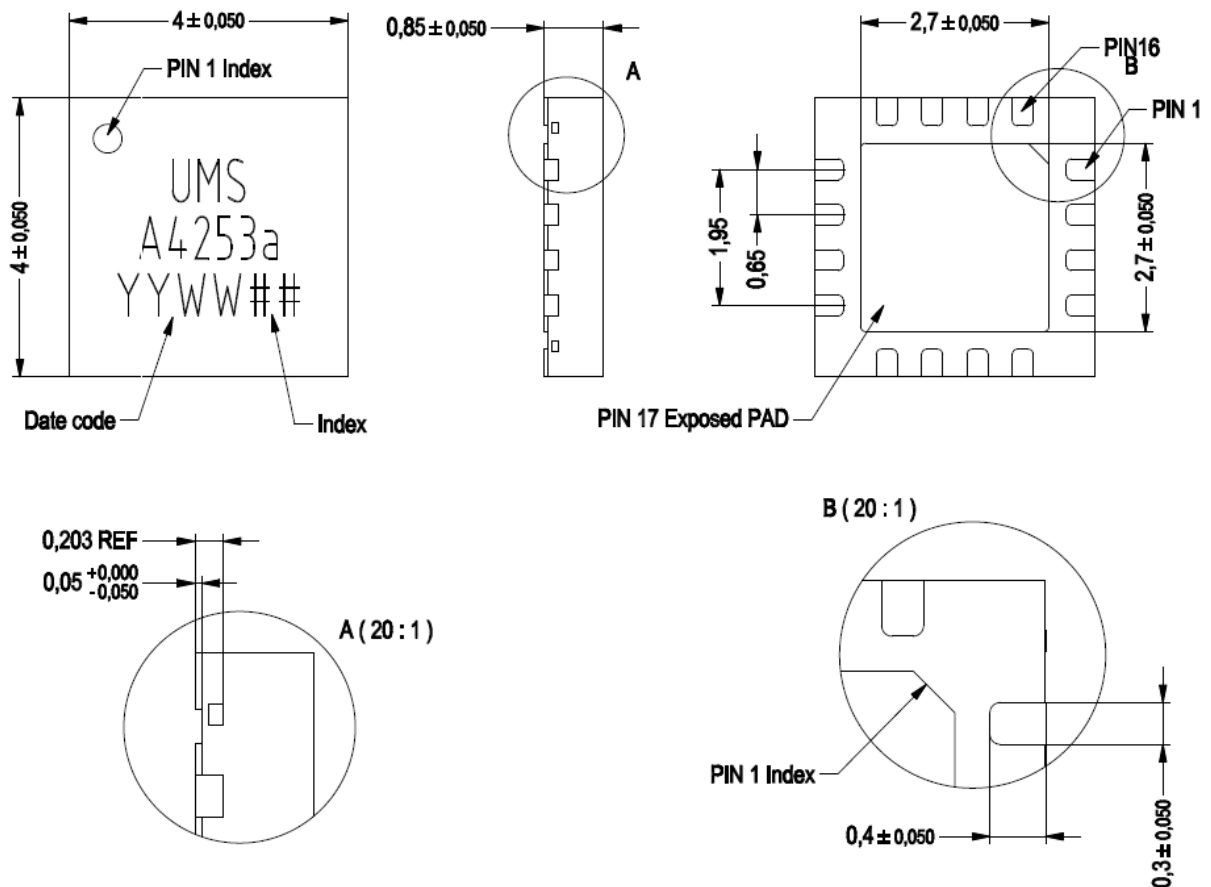

Units : mm  
 Finish : Matt tin  
 Lead free (Green)

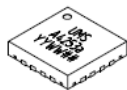

Matt tin, Lead Free (Green)	1- NC	7- Vd34	13- NC
Units : mm	2- Gnd <sup>(2)</sup>	8- NC	14- Vg34
From the standard : JEDEC MO-220 (VGGD)	3- RF IN	9- NC	15- Nc
17- GND	4- NC	10- Gnd <sup>(2)</sup>	16- Vg12
	5- Gnd <sup>(2)</sup>	11- RF OUT	
	6- Vd12	12- NC	

(1) The package outline drawing included in this data-sheet is given for indication. Refer to the application note AN0017 (<https://www.ums-rf.com>) for exact package dimensions.

(2) It is strongly recommended to ground all pins marked “Gnd” through the PCB board. Ensure that the PCB board is designed to provide the best possible ground to the package.

## Definition of the Sij reference planes

The reference planes used for Sij measurements given above are symmetrical from the symmetrical axis of the package (see drawing beside). The input and output reference planes are located at 3.18mm offset (input wise and output wise respectively) from this axis. Then, the given Sij parameters incorporate the land pattern of the evaluation motherboard recommended in paragraph "Evaluation board".

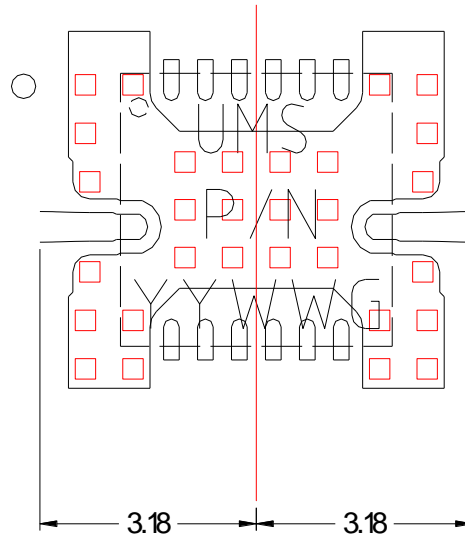

## ESD sensitivity

Standard	Value
JESD22-A114C	HBM Class 1A
	MM Class A
	CDM Class IV
ESD STM5.1-1998	HBM Class 1B
	MM Class M1
	CDM Class C7

## Package Information

Parameter	Value
Package body material	RoHS-compliant Low stress Injection Molded Plastic
Lead finish	100% Matte Tin (Sn)
MSL Rating	MSL1

## Evaluation board

- Compatible with the proposed footprint.
- Based on typically Ro4350 / 10mils or equivalent.
- Using a micro-strip to coplanar transition to access the package.
- Recommended for the implementation of this product on a module board.
- Decoupling capacitors of 100pF  $\pm$ 5% and 10nF  $\pm$ 10% are recommended for all DC accesses.
- See application note AN0017 for details.

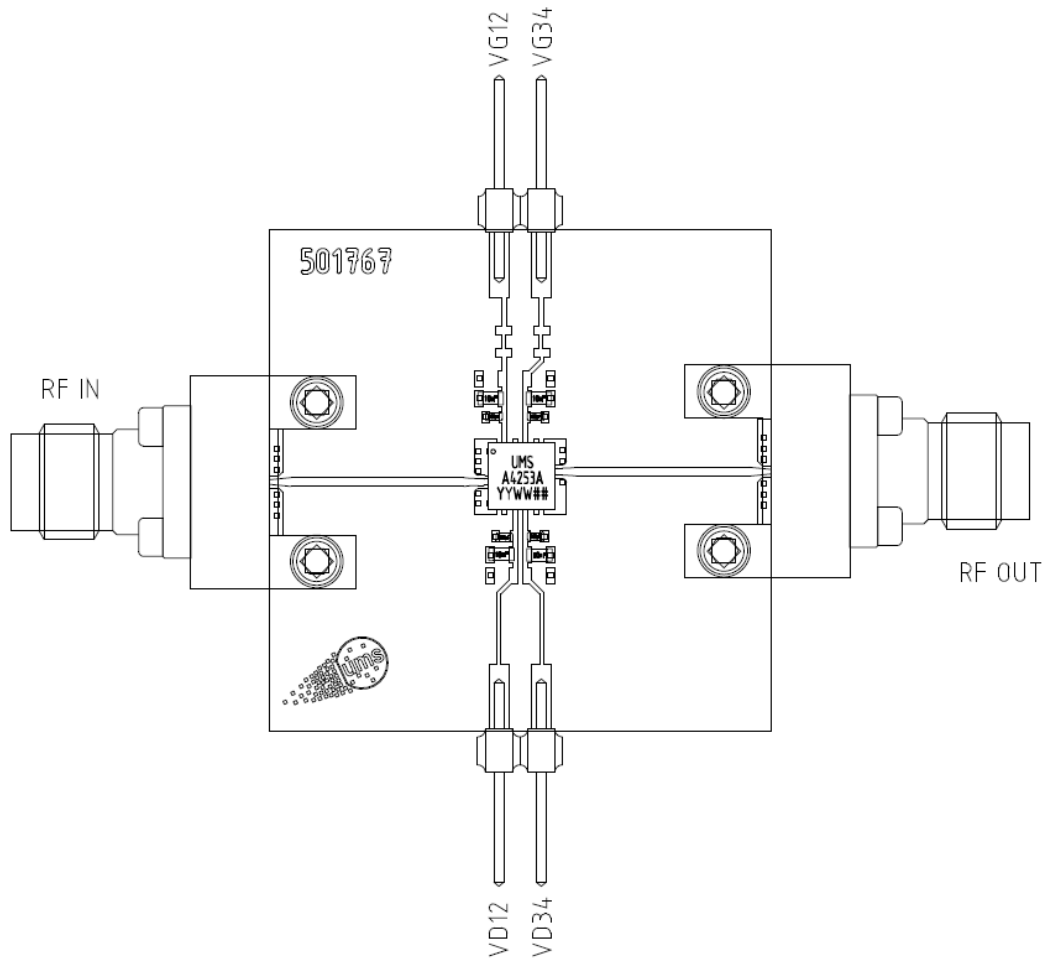

## DC Schematic

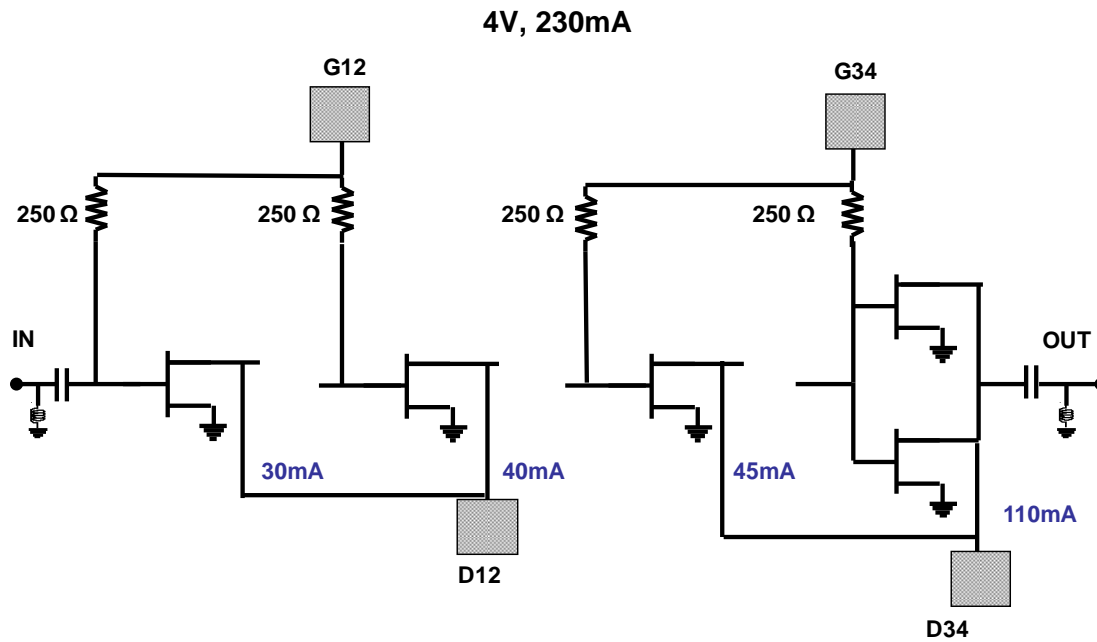

## Biassing procedure

Device Power Up instructions:

1. Ground the device
2. Bias MPA gate voltage at  $V_{gs}$  close to  $V_{pinch-off}$  (example:  $V_{gs} \approx -2V$ )
3. Apply  $V_{ds}$  quiescent bias voltage (Example:  $V_d = 4V$ )
4. Increase slowly  $V_{gs}$  up to quiescent bias drain current  $I_{dq}$
5. Apply RF input power

Device Power Down instructions:

1. Remove RF input power
2. Decrease MPA gate voltage down to  $V_{gs} -2V$
3. Decrease drain voltage down to 0V

## Notes

Due to ESD protection circuits on RF input and output, an external capacitance might be requested to isolate the product from external voltage that could be present on the RF accesses.

The DC connections do not include any decoupling capacitor in package, therefore it is mandatory to provide a good external DC decoupling (100pF, 10nF) on the PC board, as close as possible to the package.

## Recommended package footprint

Refer to the application note AN0017 available at <https://www.ums-rf.com> for package footprint recommendations.

## SMD mounting procedure

For the mounting process standard techniques involving solder paste and a suitable reflow process can be used. For further details, see application note AN0017.

## Recommended environmental management

UMS products are compliant with the regulation in particular with the directives RoHS N°2011/65 and REACH N°1907/2006. More environmental data are available in the application note AN0019 also available at <https://www.ums-rf.com>.

## Recommended ESD management

Refer to the application note AN0020 available at <https://www.ums-rf.com> for ESD sensitivity and handling recommendations for the UMS package products.

## Ordering Information

QFN 4x4 package:

CHA4253aQQG/XY

Stick: XY = 20

Tape & reel: XY = 21

Information furnished is believed to be accurate and reliable. However **United Monolithic Semiconductors S.A.S.** assumes no responsibility for the consequences of use of such information nor for any infringement of patents or other rights of third parties which may result from its use. No license is granted by implication or otherwise under any patent or patent rights of **United Monolithic Semiconductors S.A.S.** Specifications mentioned in this publication are subject to change without notice. This publication supersedes and replaces all information previously supplied. **United Monolithic Semiconductors S.A.S.** products are not authorised for use as critical components in life support devices or systems without express written approval from **United Monolithic Semiconductors S.A.S.**