

X-band Core Chip

GaAs Monolithic Microwave IC

Description

The CHC3014-99F is a Receive and Transmit X band Core Chip.

It includes a 6 bit phase shifter, a 6 bit attenuator, a second 2 bit attenuator for tuning, self-biased buffers, switch and TTL compatible parallel interfaces.

This device is manufactured 0.25 μ m pHEMT process, including via holes through the substrate.

It is available in chip form.

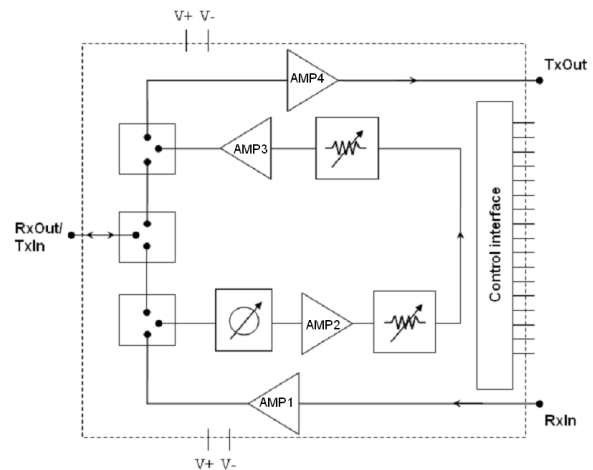

Main Features

- Operating frequency range: 8 -12GHz
- Receive path linear gain: 13.5dB
- Transmit path linear gain: 25dB
- Phase shift range: 0-360° (step 5.625°)
- Fine attenuator: 34.65dB (step 0.55dB)
- Tuning attenuator: 6dB (step 2dB)
- Chip size: 4.47 x 5.07 x 0.1mm

Main Characteristics

Tamb.= +25°C, V+ = 5V / V- = -5V

Symbol	Parameter	Min	Typ	Max	Unit
Freq	Frequency range	8		12	GHz
Rms_pe	RMS phase error		2		°
Rms_att	RMS attenuation error		0.3		dB
P _{-1dB} Rx	Output power at RX _{OUT} @1dB gain comp.		16.5		dBm
Psat Tx	Output power at TX _{OUT} at saturation		20		dBm
NF	Noise figure in Rx mode		5.8		dB

ESD Protection: Electrostatic discharge sensitive device. Observe handling precautions!

Main Characteristics (1/2)

Tamb.= +25°C

Symbol	Parameter	Min	Typ	Max	Unit
Freq	Operating frequency	8		12	GHz
Mode Rx					
GI Rx	Linear gain in Rx mode at reference state ⁽¹⁾	11.5	13.5		dB
S11 Rx	Input Return Loss in Rx mode		-14		dB
S22 Rx	Output Return Loss in Rx mode		-18		dB
NF	Noise figure in Rx mode ⁽²⁾		5.8		dB
P _{-1dB} Rx	Output power at RX _{OUT} at 1dB gain comp.		16.5		dBm
Mode Tx					
GI Tx	Linear gain in Tx mode at reference state ⁽¹⁾	22	25		dB
S11 Tx	Input Return Loss in Tx mode		-14		dB
S22 Tx	Output Return Loss in Tx mode		-12		dB
PIN Tx	Input power range in Tx saturated mode	0		15	dBm
Psat Tx	Output power at TX _{OUT} in saturated mode		20		dBm
Isolated Mode ⁽³⁾					
S11 _{ISO.}	Return Loss at RX _{in} /TX _{out}		-15		dB
6 bit Phase shifter ⁽⁴⁾					
	Phase shift elementary step		5.625		°
PPE	Peak phase error (Rx, Tx, fine attenuator state < 33 tuning attenuator state 1) 8GHz-8.5GHz 8.5GHz-11.5GHz 11.5GHz-12GHz		4 ± 6		°
			0 ± 6		
			4 ± 6		
Rms_pe	RMS phase error (Rx, Tx, fine attenuator state < 33 tuning attenuator state 1) 8GHz-8.5GHz 8.5GHz-11.5GHz 11.5GHz-12GHz		2.5		°
			2		
			2.5		
Ampvar	Amplitude variation (Rx, Tx, fine attenuator state < 33 tuning attenuator state 1)		0 ± 1		dB
Rms Ampvar	RMS Amplitude variation (Rx, Tx, fine attenuator state < 33 tuning attenuator state 1)		0.3		dB

(1) Reference state: Tuning attenuator state = 1 / Fine attenuator state = 0 /
Phase shifter state = 0

(2) Noise Figure value for Tuning attenuator state = 0 / Fine attenuator state = 0 /
Phase shifter state = 0

(3) In this mode, the MFC presents a matched load on the RF access pad Rxin/Txout

Main Characteristics (2/2)

Tamb.= +25°C

Symbol	Parameter	Min	Typ	Max	Unit
6 bit Fine Attenuator ⁽⁴⁾		34.65			dB
	Fine Attenuator elementary step		0.55		dB
Att_err _{att}	Attenuation error (Rx, all phase shifter states tuning attenuator state 1) <i>Attenuation state 0-32</i> <i>Attenuation state 33-47</i> <i>Attenuation state 48-63</i>		0 ± 0.5 -0.25 ± 0.75 -0.5 ± 1.5		dB
Rms_att	RMS attenuation error (Rx, all phase shifter states tuning attenuator state 1)		0.3		dB
Phi_var _{att}	Phase variation (Rx, all phase shifter states tuning attenuator state 1) <i>Attenuation state 0-32</i> <i>Attenuation state 33-47</i> <i>Attenuation state 48-63</i>		0 ± 3 -1 ± 5 -4 ± 6		°
Rms_Phi var	RMS Phase variation (Rx, all phase shifter states tuning attenuator state 1)		2		°
2 bit Tuning Attenuator ⁽⁵⁾		6			dB
	Tuning Attenuator elementary step		2		dB
Att_Err _{TB}	Tuning attenuation error		± 0.3		dB
Phi_var _{TB}	Phase variation of tuning attenuator		± 2		°
Biasing ⁽⁶⁾					
V+	Positive supply voltage		5		V
V-	Negative supply voltage		-5		V
TI_Low	Control voltage low level	0		0.4	V
TI_High	Control voltage high level	2.4	+3.3 / +5	7.0	V
I_+5_Rx	Biasing current in RX mode		350		mA
I_+5_Tx	Biasing current in TX mode		350 ⁽⁷⁾ 470 ⁽⁸⁾		mA
I_+5 interface	Control interface DC current		25		mA
I_-5	Negative DC current		-50		mA

(4) Low influence of cross-talking between phase shifter and fine attenuator

(5) This function allows to adjust roughly the linear gain

(6) Each Amplifiers of Rx and Tx paths can be switched off thanks to separate biasing pads (c.f. pad allocation table)

(7) Tx linear mode

(8) Tx saturated mode

Definitions

Phase(i,j) =Phase_S21 in degree
dB_S21(i,j) =dB_S21 in dB

i: Phase state index, $0 \leq i \leq 63$
j: Fine attenuation state index, $0 \leq j \leq 63$

Peak Phase Error (PPE)

$PPE(i,j) = \text{Measured_Phase}(S21)@state(i,j) - \text{Measured_Phase}(S21)@state(0,j) - \text{theoreticalPhaseValue}@State(i,j)$

Amplitude Variation (Ampvar)

$Ampvar(i,j) = \text{Measured_dB_S21}@state(i,j) - \text{Measured_dB_S21}@state(0,j)$
(i is the phase state and in the range [0:63])

The translation of Ampvar(i,j) from dB to linear is given by: $Ampvar(i,j)_{lin} = 10^{\frac{Ampvar(i,j)}{20}}$

Attenuation Error (Att_err_att)

$Att_err(i,j) = \text{Measured_dB_S21}@state(i,j) - \text{Measured_dB_S21}@state(i,0) - \text{theoretical_dB_S21}@state(i,j)$

The translation of Att_err(i,j) from dB to linear is given by: $Att_err(i,j)_{lin} = 10^{\frac{Att_err(i,j)}{20}}$

Phase variation (Phivar_att)

$Phivar(i,j) = \text{Measured_Phase}(S21)@state(i,j) - \text{Measured_Phase}(S21)@state(i,0)$

RMS Peak Phase Error (Rms_pe)

$$Rms_pe = \sqrt{\frac{\sum_{i=0}^{63} (PPE(i, j) - \overline{PPE})^2}{64}}$$

$$\text{Where } \overline{PPE} = \frac{\sum_{i=0}^{63} PPE(i, j)}{64}$$

RMS Amplitude Variation (Rms_Ampvar)

$$Rms_Ampvar = 20 \log \left(1 + \sqrt{\frac{1}{64} \cdot \sum_{i=0}^{63} (1 - Ampvar(i, j)_{lin})^2} \right) \text{ (dB)}$$

RMS Attenuation Error (Rms_att)

$$\text{Rms_att} = 20 \log \left(1 + \sqrt{\frac{1}{64} \cdot \sum_{i=0}^{63} (1 - \text{Att_err}(i, j)_{\text{lin}})^2} \right) \text{ (dB)}$$

RMS Phase variation (Rms_Phivar)

$$\text{Rms_Phivar} = \sqrt{\frac{\sum_{j=0}^{63} (\text{Phi var}(i, j))^2}{64}} \text{ (}^\circ\text{)}$$

Absolute Maximum RatingsTamb.= +25°C⁽¹⁾

Symbol	Parameter	Values	Unit
V+	Maximum positive bias voltage	6	V
V-	Negative voltage range	-6 to -4	V
P_RF _{RX}	Maximum peak input power overdrive in Rx mode	16	dBm
P_RF _{TX}	Maximum peak input power overdrive in Tx mode	16	dBm
Ai	CTRL voltage (TI_low, TI_high)	-2, +8	V
Tch	Maximum channel temperature ⁽²⁾	175	°C
Ta	Operating temperature range	-40 to +85	°C
Tstg	Storage temperature range	-55 to +150	°C

⁽¹⁾ Operation of this device above anyone of these parameters may cause permanent damage.⁽²⁾ Thermal Resistance channel to ground paddle = 40°C/W for T= +85°C

Typical on wafer Measurements

Tamb.= +25°C

[S] parameters in Rx mode

S21 vs. Frequency
Tuning attenuator states 0-1-2-3
Fine attenuator state 0, Phase shifter state 0

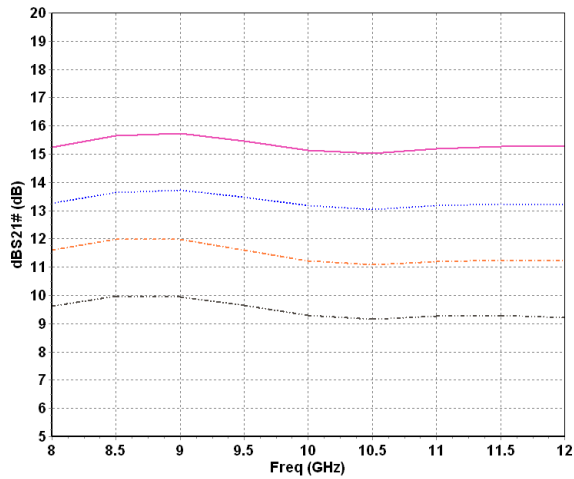

Noise Factor vs. Frequency
Tuning attenuator states 0-1-2-3
Fine attenuator state 0, Phase shifter state 0

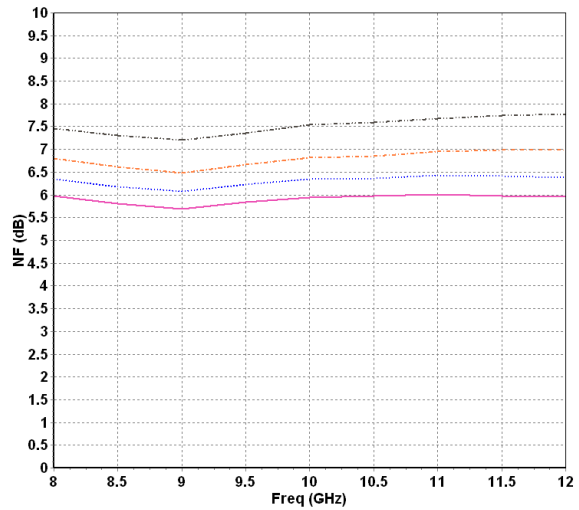

S11 vs. Frequency
Tuning attenuator states 0-1-2-3
Fine attenuator states 0-1-2-4-8-16-32-63
Phase shifter states 0-1-2-4-8-16-32-63

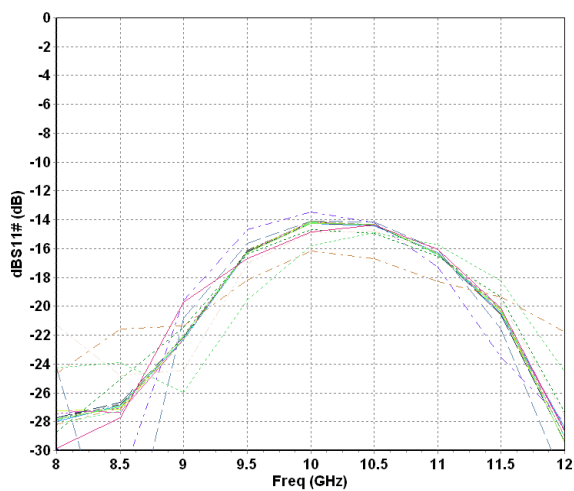

S22 vs. Frequency
Tuning attenuator states 0-1-2-3
Fine attenuator states 0-1-2-4-8-16-32-63
Phase shifter states 0-1-2-4-8-16-32-63

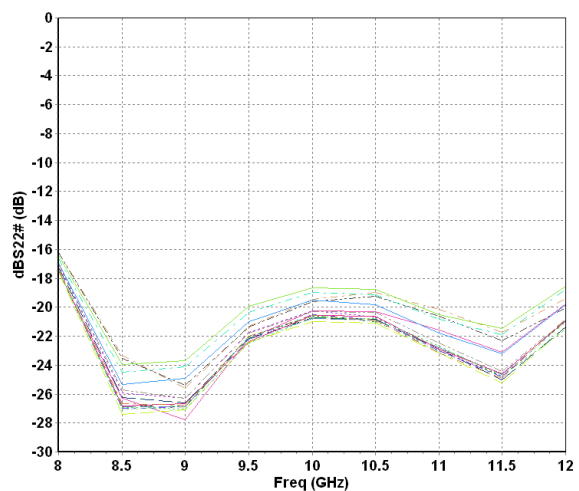

Typical on wafer Measurements

Tamb.= +25°C

[S] parameters in Tx mode

S21 vs. Frequency
 Tuning attenuator state 1
 Fine attenuator state 0, Phase shifter state 0

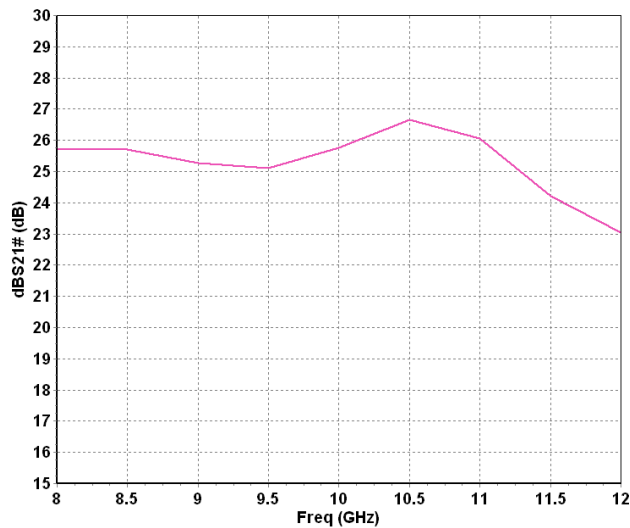

S11 vs. Frequency
 Tuning attenuator state 1, Fine attenuator state 0
 Phase shifter states 0-1-2-4-8-16-32-63

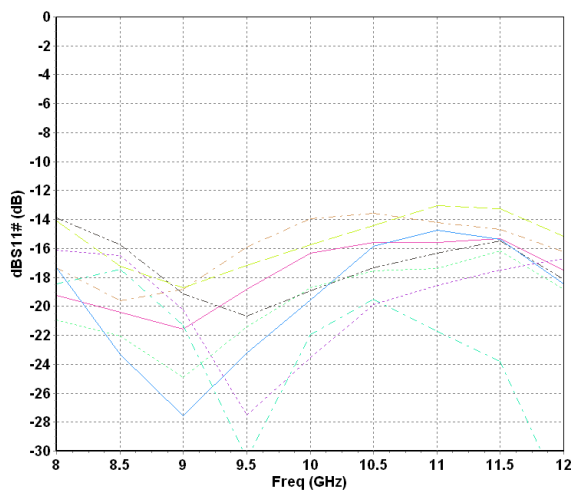

S22 vs. Frequency
 Tuning attenuator state 1, Fine attenuator state 0
 Phase shifter states 0-1-2-4-8-16-32-63

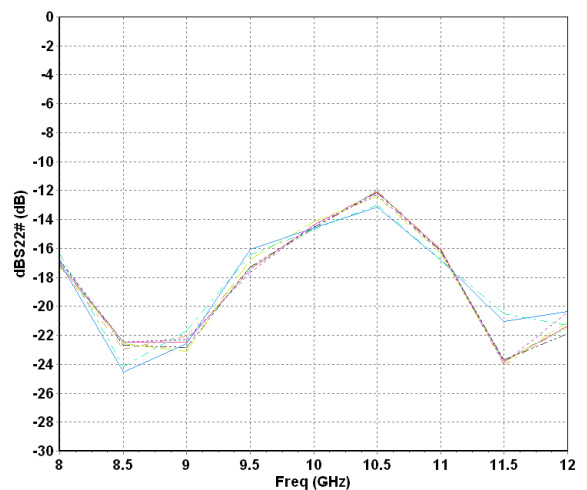

Typical on wafer Measurements

Tamb.= +25°C

Phase shifter performances: Phase error Rx and Tx mode

Phase error vs. frequency
Tuning attenuator state 1
Fine attenuator states 0-8-16-32

All phase states

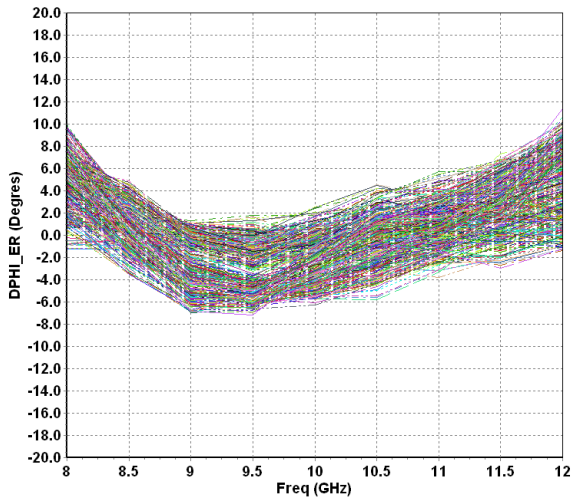

Phase error vs. phase state
for attenuation states 0, 8, 16, 32

8GHz < Freq. < 12GHz

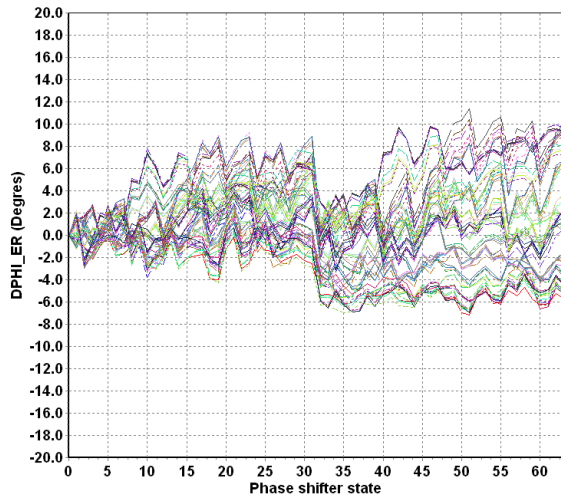

Phase error RMS

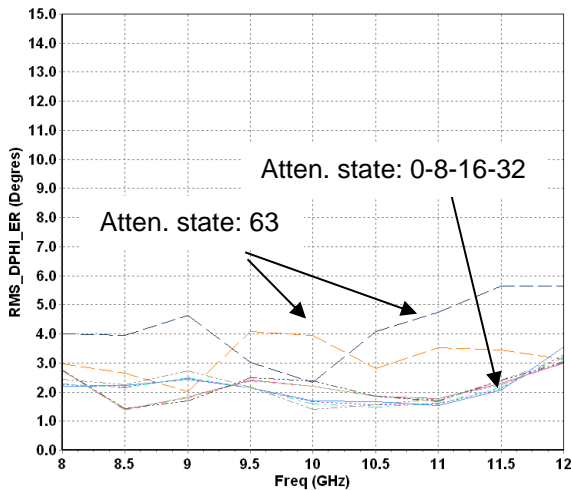

Phase shift vs. phase shifter state
Tuning attenuator state 1
Fine attenuator states 0-8-16-32
Freq. = 10GHz

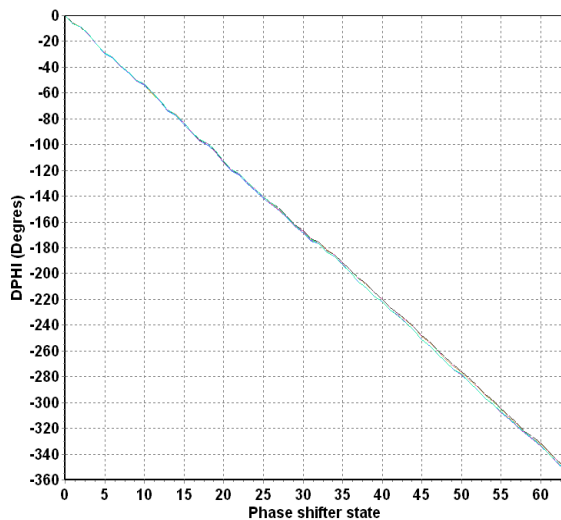

Typical on wafer Measurements

Tamb.= +25°C

Phase shifter performances: Amplitude variation
Rx and Tx mode

Amplitude variation vs. frequency
Tuning attenuator state 1
Fine attenuator states 0-8-16-32

All phase states

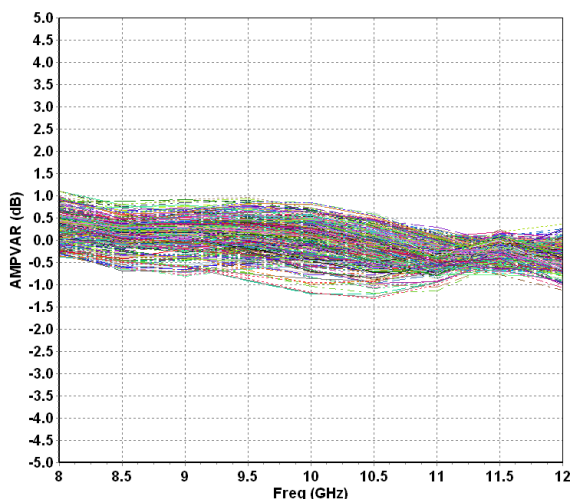

Amplitude variation vs. phase state
Tuning attenuator state 1
Fine attenuator states 0-8-16-32

8GHz < Freq. < 12GHz

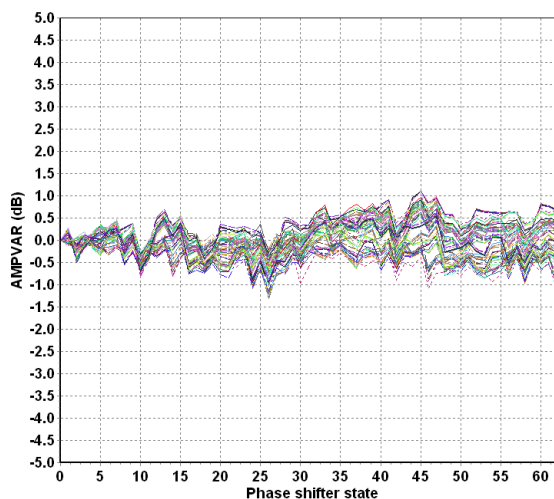

Amplitude variation RMS
Tuning attenuator state 1
Fine attenuator states 0-8-16-32

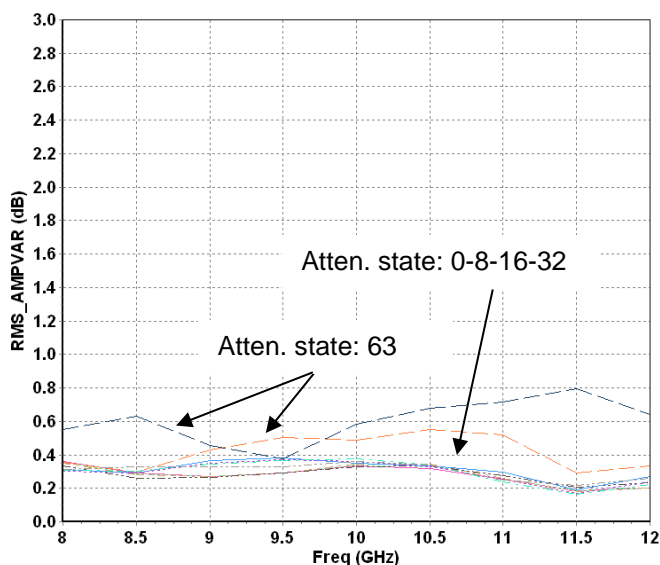

Typical on wafer Measurements

Tamb.= +25°C

Fine Attenuator performances: Attenuation error Rx mode

Attenuation error vs. freq.
Tuning attenuator state 1
Phase shifter states 0-8-16-32-63

All fine attenuator states

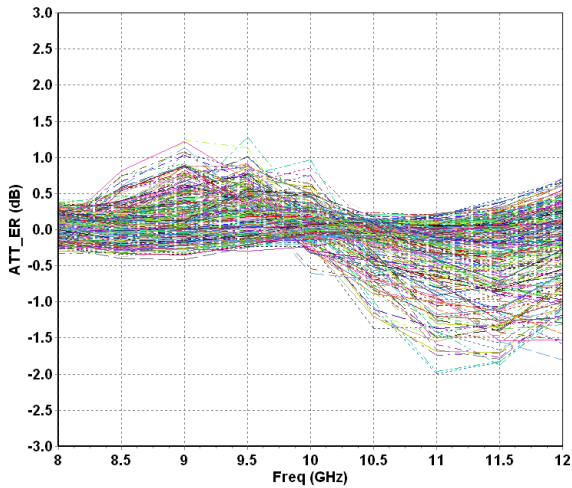

Attenuation error vs. atten. state
Tuning attenuator state 1
Phase shifter states 0-8-16-32-63

8GHz < Freq. < 12GHz

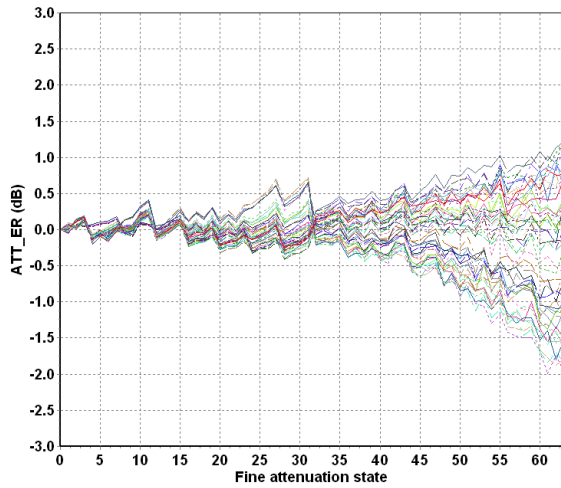

RMS attenuation error
Tuning attenuator state 1
Phase shifter states 0-8-16-32-63

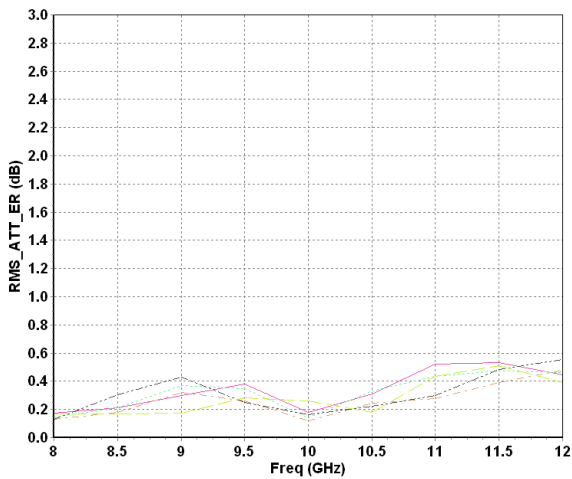

Attenuation vs. Fine attenuator state
Tuning attenuator state 1
Phase shifter states 0-8-16-32-63
Freq. = 10GHz

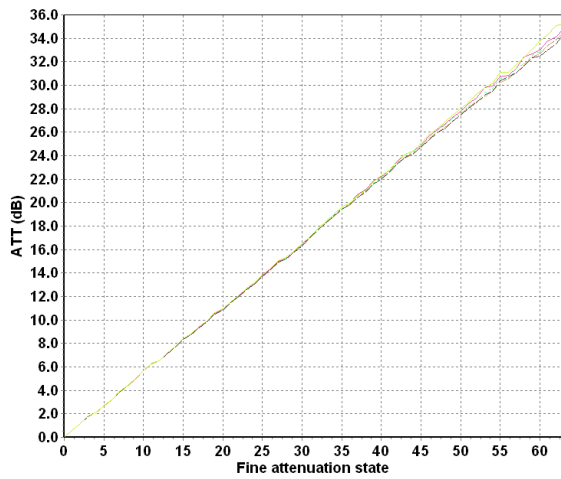

Typical on wafer Measurements

Tamb.= +25°C

Fine Attenuator performances: phase variation
Rx mode

Phase variation vs. freq.
Tuning attenuator state 1
Phase shifter states 0-8-16-32-63

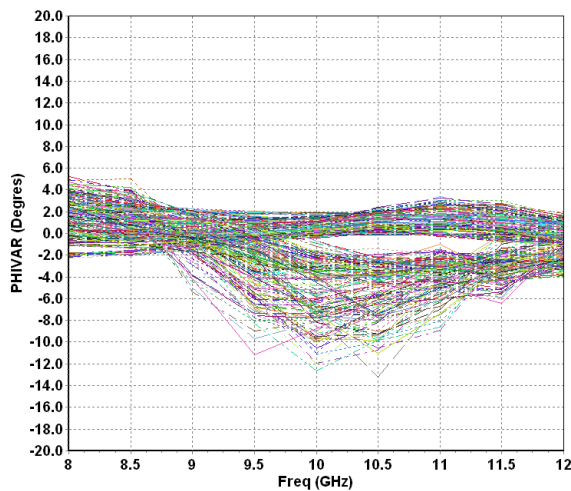

Phase variation vs. atten. state
Tuning attenuator state 1
Phase shifter states 0-8-16-32-63

8GHz < Freq. < 12GHz

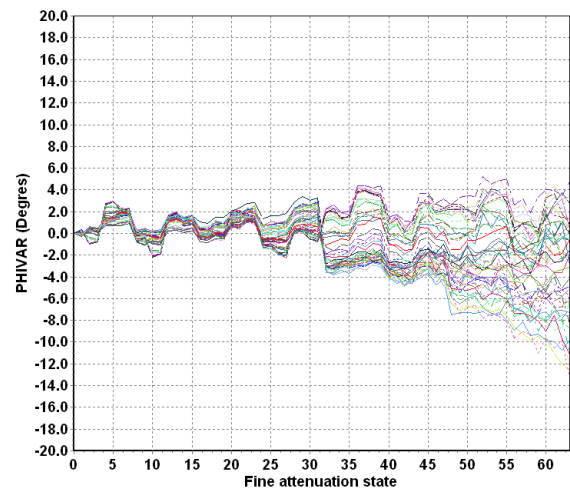

RMS phase variation
Tuning attenuator state 1
Phase shifter states 0-8-16-32-63

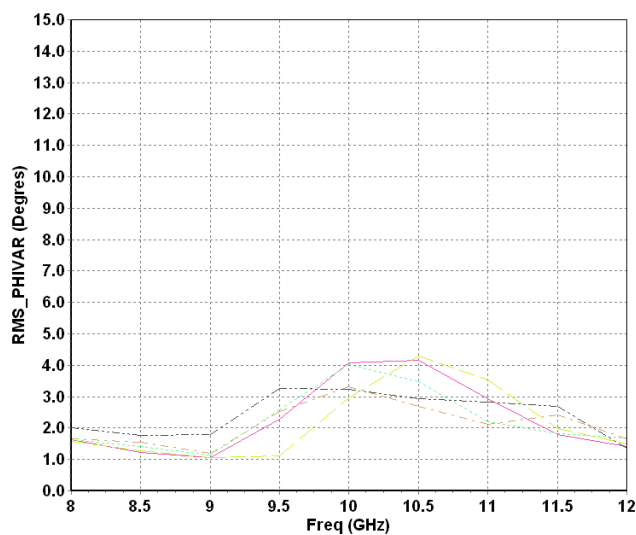

Typical on wafer Measurements

Tamb.= +25°C

Tuning Attenuator performances Rx mode

Tuning attenuation error vs. freq.
Fine attenuator state 0, Phase shifter state 0
Attenuation states 0–1–2-3

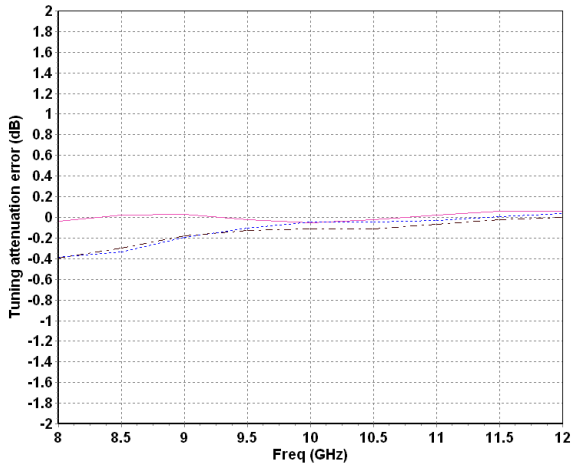

Tuning attenuation error vs. attenuation state
Fine attenuator state 0, Phase shifter state 0

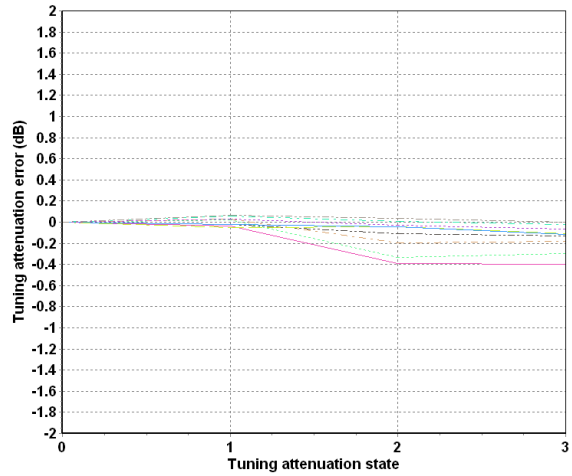

Tuning attenuation vs. tuning atten. state at 10GHz
Fine attenuator state 0, Phase shifter state 0

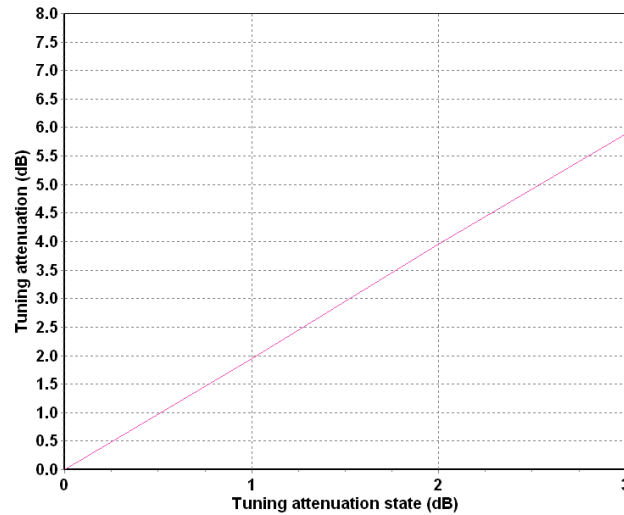

Typical Test Fixture Measurements in Temperature

Tamb = [-40, +25, 85] °C

These values are representative of de-embedded onboard measurements as defined on the drawing 98658.

[S] parameter in RX mode

S21 vs. Frequency
 Tuning attenuator states 1
 Fine attenuator state 0, Phase shifter state 0

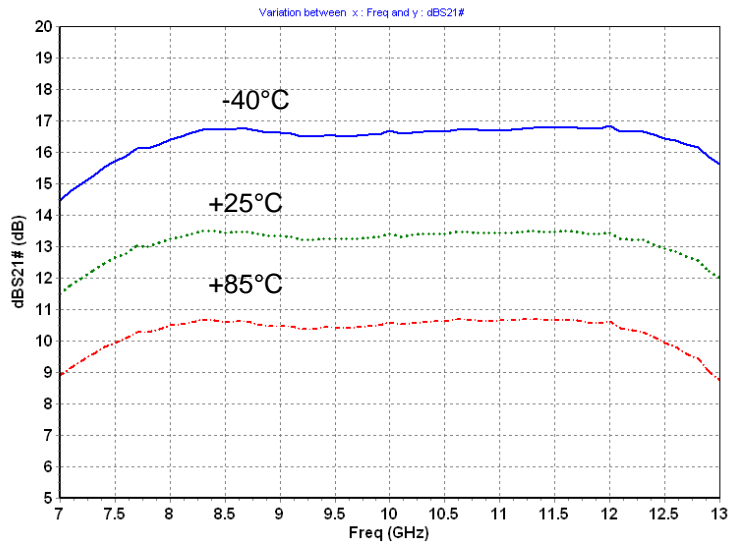

[S] parameter in TX mode

S21 vs. Frequency
 Tuning attenuator states 1
 Fine attenuator state 0, Phase shifter state 0

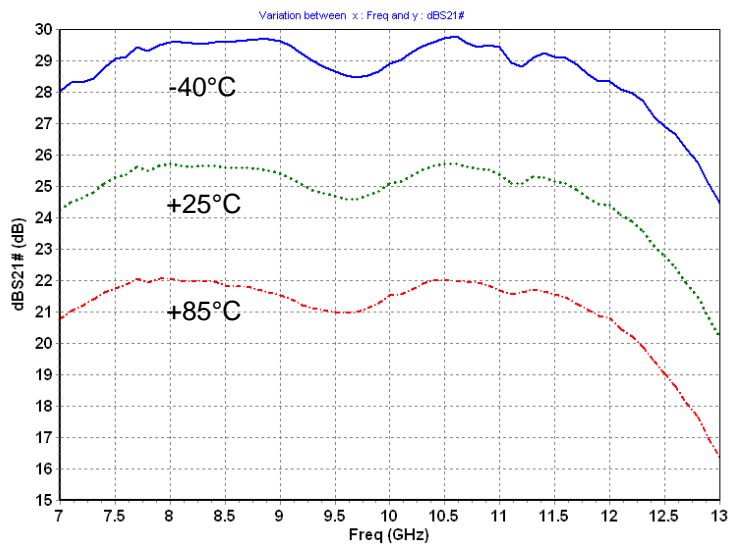

Mechanical data

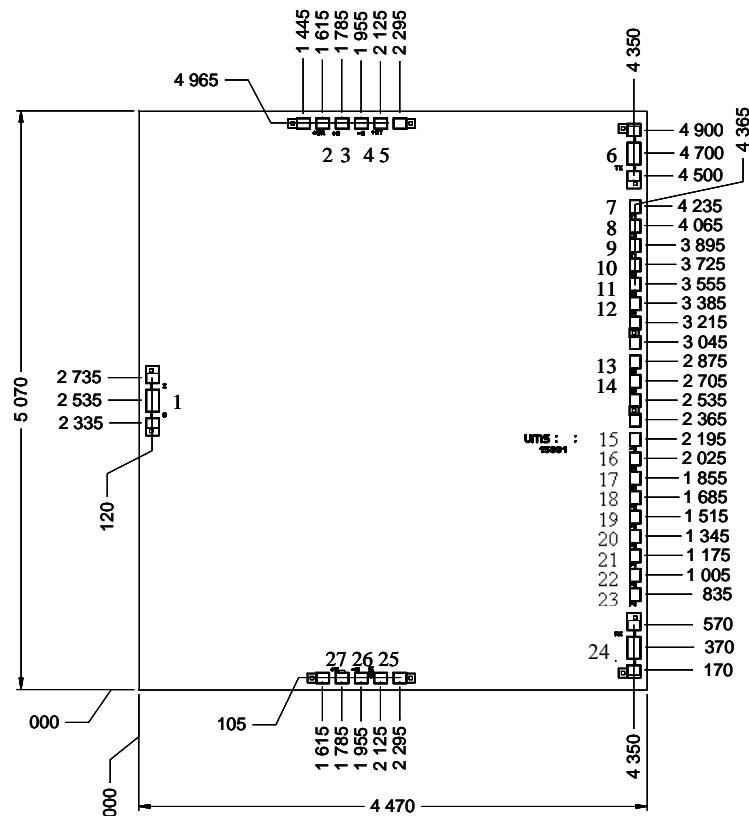

Chip thickness = 100µm +/- 10µm.

RF pads (1, 6, 24) = 122 x 200µm²

DC and control pads (2, 3, 4, 5, 7 to 23, 25, 26, 27) = 120 x 100µm²

Pin number	Pad name	Description	Pin number	Pad name	Description
1	IO	Input/Output RF: RXout. TXin	15	-5	-5V supply voltage: interface
2	+5R	+5V supply voltage Amp. 3	16	SA	Switch bit 1
3	+5	+5V supply voltage : interface	17	SB	Switch bit 2
4	-5	-5V supply voltage	18	P1	Phase shifter bit 1
5	+5T	+5V supply voltage Amp. 4	19	P2	Phase shifter bit 2
6	TX	Output RF: TXout	20	P3	Phase shifter bit 3
7	C1	Coarse attenuator bit 1	21	P4	Phase shifter bit 4
8	C2	Coarse attenuator bit 2	22	P5	Phase shifter bit 5
9	A1	Attenuator bit 1	23	P6	Phase shifter bit 6
10	A2	Attenuator bit 2	24	Rx	Input RF: RXin
11	A3	Attenuator bit 3	25	+5R	+5V supply voltage Amp. 1
12	A4	Attenuator bit 4	26	-5	-5V supply voltage
13	A5	Attenuator bit 5	27	+5	+5V supply voltage Amp. 2
14	A6	Attenuator bit 6			

Evaluation Mother board 98658

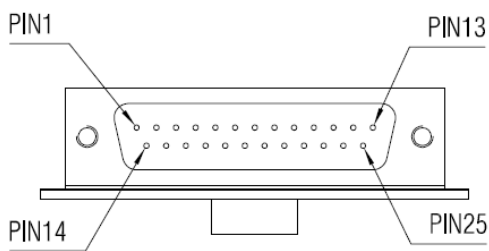
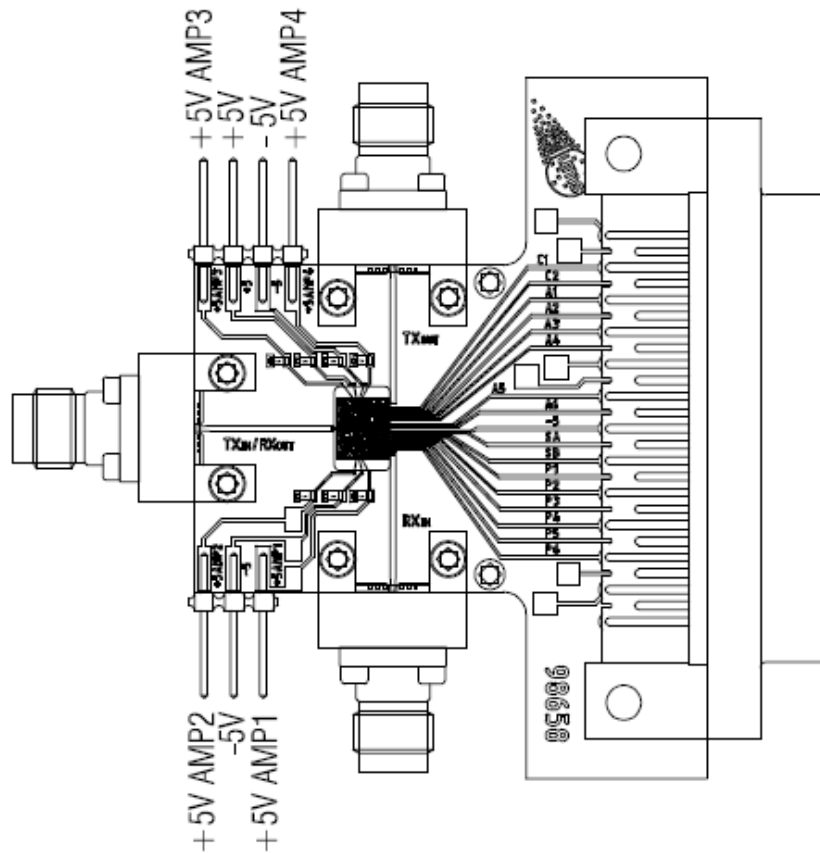

SUB-D Pin out:				
1- Gnd	6- SB	11- A1	16- P5	21- Nc
2- Nc	7- -5V	12- C1	17- P3	22- A4
3- P6	8- A5	13- Nc	18- P1	23- A2
4- P4	9- Nc	14- Nc	19- SA	24- C2
5- P2	10- A3	15- Nc	20- A6	25- Nc

Recommended assembly plan

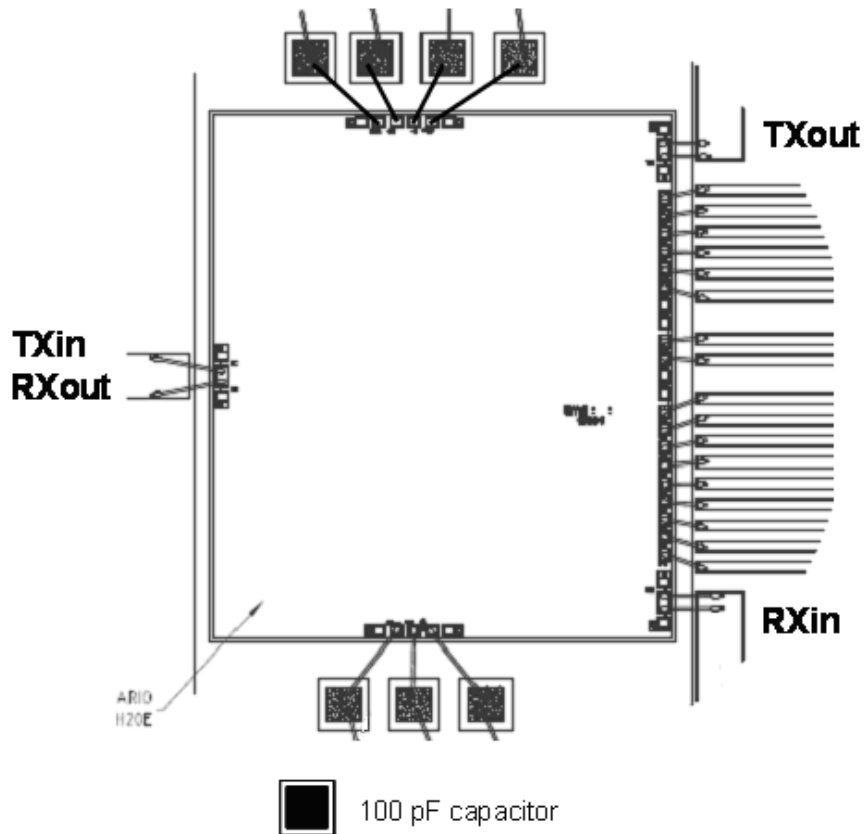

Note: Biasing pads 2-5-25-27 can be commonly connected to the +5V supply voltage

Bonding length recommendations

Pad name	Description	Connection
IO (Pad 1)	TXin/Rxout	Inductance (Lbonding) = 0.3nH Two wires: diameter 25µm, length 0.470µm
TX (Pad 6)	Txout	
RX (Pad 24)	RXin	
All others	DC and Interface pads	Inductance (Lbonding) = 0.8nH One wire: diameter 25µm, length 1mm

Operating mode

General Biasing conditions

Pin number	Pad name	Value	Pin number	Pad name	Value
2	+5R	+5V	15	-5	-5V
3	+5	+5V	16	SA	0 or 3.3V
4	-5	-5V	17	SB	0 or 3.3V
5	+5T	+5V	18	P1	0 or 3.3V
7	C1	0 or 3.3V	19	P2	0 or 3.3V
8	C2	0 or 3.3V	20	P3	0 or 3.3V
9	A1	0 or 3.3V	21	P4	0 or 3.3V
10	A2	0 or 3.3V	22	P5	0 or 3.3V
11	A3	0 or 3.3V	23	P6	0 or 3.3V
12	A4	0 or 3.3V	25	+5R	+5V
13	A5	0 or 3.3V	26	-5	-5V
14	A6	0 or 3.3V	27	+5	+5V

Switch control table

Voltage to apply on the pads SA SB:

	SA	SB
Adaptative Isolation mode	3.3	3.3
RX path	3.3	0
TX path	0	3.3
Not used	0	0

Note: When the MFC is used in adaptative isolation mode, it presents a matched load to the RF access pad RXin/TXout

Tuning attenuator control table

Voltages to apply on the pads C1 C2:

state	Att (dB)	C2	C1
0	0	0	0
1	2	0	3.3
2	4	3.3	0
3	6	3.3	3.3

Coarse bit control table

Attenuator control table

Voltage to apply on the pads A1 to A6:

state	Att (dB)	A6	A5	A4	A3	A2	A1	state	Att (dB)	A6	A5	A4	A3	A2	A1
0	0	0	0	0	0	0	0	33	18.15	3.3	0	0	0	0	3.3
1	0.55	0	0	0	0	0	3.3	34	18.7	3.3	0	0	0	3.3	0
2	1.1	0	0	0	0	3.3	0	35	19.25	3.3	0	0	0	3.3	3.3
3	1.65	0	0	0	0	3.3	3.3	36	19.8	3.3	0	0	3.3	0	0
4	2.2	0	0	0	3.3	0	0	37	20.35	3.3	0	0	3.3	0	3.3
5	2.75	0	0	0	3.3	0	3.3	38	20.9	3.3	0	0	3.3	3.3	0
6	3.3	0	0	0	3.3	3.3	0	39	21.45	3.3	0	0	3.3	3.3	3.3
7	3.85	0	0	0	3.3	3.3	3.3	40	22	3.3	0	3.3	0	0	0
8	4.4	0	0	3.3	0	0	0	41	22.55	3.3	0	3.3	0	0	3.3
9	4.95	0	0	3.3	0	0	3.3	42	23.1	3.3	0	3.3	0	3.3	0
10	5.5	0	0	3.3	0	3.3	0	43	23.65	3.3	0	3.3	0	3.3	3.3
11	6.05	0	0	3.3	0	3.3	3.3	44	24.2	3.3	0	3.3	3.3	0	0
12	6.6	0	0	3.3	3.3	0	0	45	24.75	3.3	0	3.3	3.3	0	3.3
13	7.15	0	0	3.3	3.3	0	3.3	46	25.3	3.3	0	3.3	3.3	3.3	0
14	7.7	0	0	3.3	3.3	3.3	0	47	25.85	3.3	0	3.3	3.3	3.3	3.3
15	8.25	0	0	3.3	3.3	3.3	3.3	48	26.4	3.3	3.3	0	0	0	0
16	8.8	0	3.3	0	0	0	0	49	26.95	3.3	3.3	0	0	0	3.3
17	9.35	0	3.3	0	0	0	3.3	50	27.5	3.3	3.3	0	0	3.3	0
18	9.9	0	3.3	0	0	3.3	0	51	28.05	3.3	3.3	0	0	3.3	3.3
19	10.45	0	3.3	0	0	3.3	3.3	52	28.6	3.3	3.3	0	3.3	0	0
20	11	0	3.3	0	3.3	0	0	53	29.15	3.3	3.3	0	3.3	0	3.3
21	11.55	0	3.3	0	3.3	0	3.3	54	29.7	3.3	3.3	0	3.3	3.3	0
22	12.1	0	3.3	0	3.3	3.3	0	55	30.25	3.3	3.3	0	3.3	3.3	3.3
23	12.65	0	3.3	0	3.3	3.3	3.3	56	30.8	3.3	3.3	3.3	0	0	0
24	13.2	0	3.3	3.3	0	0	0	57	31.35	3.3	3.3	3.3	0	0	3.3
25	13.75	0	3.3	3.3	0	0	3.3	58	31.9	3.3	3.3	3.3	0	3.3	0
26	14.3	0	3.3	3.3	0	3.3	0	59	32.45	3.3	3.3	3.3	0	3.3	3.3
27	14.85	0	3.3	3.3	0	3.3	3.3	60	33	3.3	3.3	3.3	3.3	0	0
28	15.4	0	3.3	3.3	3.3	0	0	61	33.55	3.3	3.3	3.3	3.3	0	3.3
29	15.95	0	3.3	3.3	3.3	0	3.3								
30	16.5	0	3.3	3.3	3.3	3.3	0								
31	17.05	0	3.3	3.3	3.3	3.3	3.3								
32	17.6	3.3	0	0	0	0	0								

Fine attenuator control table

Phase shifter control table

Voltage to apply on the pads P1 to P6:

state	Phase (deg)	P6	P5	P4	P3	P2	P1	state	Phase (deg)	P6	P5	P4	P3	P2	P1
0	0	0	0	0	0	0	0	33	-185.625	3.3	0	0	0	0	3.3
1	-5.625	0	0	0	0	0	3.3	34	-191.25	3.3	0	0	0	3.3	0
2	-11.25	0	0	0	0	3.3	0	35	-196.875	3.3	0	0	0	3.3	3.3
3	-16.875	0	0	0	0	3.3	3.3	36	-202.5	3.3	0	0	3.3	0	0
4	-22.5	0	0	0	3.3	0	0	37	-208.125	3.3	0	0	3.3	0	3.3
5	-28.125	0	0	0	3.3	0	3.3	38	-213.75	3.3	0	0	3.3	3.3	0
6	-33.75	0	0	0	3.3	3.3	0	39	-219.375	3.3	0	0	3.3	3.3	3.3
7	-39.375	0	0	0	3.3	3.3	3.3	40	-225	3.3	0	3.3	0	0	0
8	-45	0	0	3.3	0	0	0	41	-230.625	3.3	0	3.3	0	0	3.3
9	-50.625	0	0	3.3	0	0	3.3	42	-236.25	3.3	0	3.3	0	3.3	0
10	-56.25	0	0	3.3	0	3.3	0	43	-241.875	3.3	0	3.3	0	3.3	3.3
11	-61.875	0	0	3.3	0	3.3	3.3	44	-247.5	3.3	0	3.3	3.3	0	0
12	-67.5	0	0	3.3	3.3	0	0	45	-253.125	3.3	0	3.3	3.3	0	3.3
13	-73.125	0	0	3.3	3.3	0	3.3	46	-258.75	3.3	0	3.3	3.3	3.3	0
14	-78.75	0	0	3.3	3.3	3.3	0	47	-264.375	3.3	0	3.3	3.3	3.3	3.3
15	-84.375	0	0	3.3	3.3	3.3	3.3	48	-270	3.3	3.3	0	0	0	0
16	-90	0	3.3	0	0	0	0	49	-275.625	3.3	3.3	0	0	0	3.3
17	-95.625	0	3.3	0	0	0	3.3	50	-281.25	3.3	3.3	0	0	3.3	0
18	-101.25	0	3.3	0	0	3.3	0	51	-286.875	3.3	3.3	0	0	3.3	3.3
19	-106.875	0	3.3	0	0	3.3	3.3	52	-292.5	3.3	3.3	0	3.3	0	0
20	-112.5	0	3.3	0	3.3	0	0	53	-298.125	3.3	3.3	0	3.3	0	3.3
21	-118.125	0	3.3	0	3.3	0	3.3	54	-303.75	3.3	3.3	0	3.3	3.3	0
22	-123.75	0	3.3	0	3.3	3.3	0	55	-309.375	3.3	3.3	0	3.3	3.3	3.3
23	-129.375	0	3.3	0	3.3	3.3	3.3	56	-315	3.3	3.3	3.3	0	0	0
24	-135	0	3.3	3.3	0	0	0	57	-320.625	3.3	3.3	3.3	0	0	3.3
25	-140.625	0	3.3	3.3	0	0	3.3	58	-326.25	3.3	3.3	3.3	0	3.3	0
26	-146.25	0	3.3	3.3	0	3.3	0	59	-331.875	3.3	3.3	3.3	0	3.3	3.3
27	-151.875	0	3.3	3.3	0	3.3	3.3	60	-337.5	3.3	3.3	3.3	3.3	0	0
28	-157.5	0	3.3	3.3	3.3	0	0	61	-343.125	3.3	3.3	3.3	3.3	0	3.3
29	-163.125	0	3.3	3.3	3.3	0	3.3								
30	-168.75	0	3.3	3.3	3.3	3.3	0								
31	-174.375	0	3.3	3.3	3.3	3.3	3.3								
32	-180	3.3	0	0	0	0	0								

Phase shifter control table

Recommended ESD management

Refer to the application note AN0020 available at <https://www.ums-rf.com> for ESD sensitivity and handling recommendations for the UMS products.

Ordering Information

Chip form: CHC3014-99F/00

Information furnished is believed to be accurate and reliable. However **United Monolithic Semiconductors S.A.S.** assumes no responsibility for the consequences of use of such information nor for any infringement of patents or other rights of third parties which may result from its use. No license is granted by implication or otherwise under any patent or patent rights of **United Monolithic Semiconductors S.A.S.**. Specifications mentioned in this publication are subject to change without notice. This publication supersedes and replaces all information previously supplied. **United Monolithic Semiconductors S.A.S.** products are not authorised for use as critical components in life support devices or systems without express written approval from **United Monolithic Semiconductors S.A.S.**