

CHT-MOON DATASHEET

Version: 1.4
2-Jan-18
(Last Modification Date)

High-Temperature Medium Power Dual N-channel MOSFET

General description

The CHT-MOON is a dual, high-voltage N-channel MOSFET in a very dense CSOIC16 SMD package. It is designed to achieve high performance in an extremely wide temperature range: typical operation temperature goes from -55°C to 225°C while keeping leakage currents low.

It has been optimized for use in low and medium power DC-DC converters such as synchronous buck operation, in combination with CISSOID' PWM controller CHT-MAGMA. This product is ideal for compact, high-efficiency DC-DC converters that supply voltages to applications where the operating temperature is high or (and) where reliability is critical.

Features

- Specified from -55 to +225°C (Tj)
- Drain voltage up to 40V
- R_{DSon} (per transistor): 0.65Ω @ 225°C
- VGS =0V to +5V
- Reverse ESD diode between gate and source.
- Available in CSOIC16 package
- Validated at 225°C for 20000 hours (and still on-going)

Applications

- SMPS, PoL and DC/DC converters
- Low and medium-power push-pull stages in motor drives and inverters

Refer to <http://www.cissoid.com/files/files/products/planet/CHT-MOON.pdf> for latest datasheet version.

Package configurations

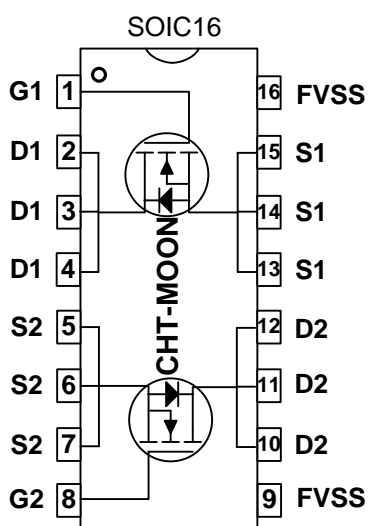

Pin #	Pin Name	Pin Description
1	G1	MOSFET1 gate
2	D1	MOSFET1 drain
3	D1	MOSFET1 drain
4	D1	MOSFET1 drain
5	S2	MOSFET2 source
6	S2	MOSFET2 source
7	S2	MOSFET2 source
8	G2	MOSFET2 gate
9	FVSS	Input pin; to be connected to lowest voltage
10	D2	MOSFET2 drain
11	D2	MOSFET2 drain
12	D2	MOSFET2 drain
13	S1	MOSFET1 source
14	S1	MOSFET1 source
15	S1	MOSFET1 source
16	FVSS	Input pin; to be connected to lowest voltage

**CHT-MOON- High-Temperature Medium Power
Dual N-channel MOSFET – DATASHEET**

(Last Modification Date)

Absolute Maximum Ratings

Gate-to-Source voltage V_{GS}	-0.5V to 5.5V
Drain-to-Source voltage V_{DS}	0V to 40V
$V_{BACK}-V_{S1}$	between -80V and 10V
$V_{BACK}-V_{S2}$	between -80V and 10V
Pulsed drain current I_{DS} ($T_{pulse} \leq 2\mu s$):	7A @ -55°C 6A @ 25°C 4A @ 225°C
DC drain current ($V_{GS}=5V$) (1 NMOS)	3A
Power dissipation $T_c=25^\circ C$	3.33W

Operating Conditions

Gate-to-Source voltage V_{GS}	0V to 5V
Drain-to-Source voltage V_{DS}	0V to 40V
Junction temperature	-55°C to +225°C

See Thermal characteristics for power derating with temperature

ESD Rating (expected)

Human Body Model	2kV
------------------	-----

Stresses above those listed in "Absolute Maximum Ratings" may cause permanent damage to the device. This is a stress only rating and operation of the device at these or any other conditions above those indicated in the operational sections of this specification is not implied. Frequent or extended exposure to absolute maximum rating conditions or above may affect device reliability. Gate terminals are ESD sensitive; please use appropriate handling methods.

(Last Modification Date)

Electrical characteristics (per MOSFET)

DC Characteristics

 Unless otherwise stated, $T_j = 25^\circ\text{C}$. **Bold** figures point out values valid over the whole temperature range ($T_j = -55^\circ\text{C}$ to $+225^\circ\text{C}$).

Parameter	Symbol	Condition	Min	Typ	Max	Unit
Threshold voltage	V_{TH}	$V_{DS} = 50\text{mV}$	0.85	1.6	1.95	V
Drain cut-off current	I_{DSS}	$V_{GS} = 0\text{V}, V_{DS} = 40\text{V}, T_j = 25^\circ\text{C}$		15		nA
		$V_{GS} = 0\text{V}, V_{DS} = 40\text{V}, T_j = 225^\circ\text{C}$		8		uA
Gate leakage current ¹	I_{GSS}	$V_{GS} = 5\text{V}, V_{DS} = 50\text{mV}, T_j = 25^\circ\text{C}$		189		pA
		$V_{GS} = 5\text{V}, V_{DS} = 50\text{mV}, T_j = 225^\circ\text{C}$		72.1		nA
Static drain-to-source resistance	$R_{DS(on)}$	$V_{GS} = 5\text{V}, V_{DS} = 50\text{mV}, T_j = -55^\circ\text{C}$		0.3		Ω
		$V_{GS} = 5\text{V}, V_{DS} = 50\text{mV}, T_j = 25^\circ\text{C}$		0.38		Ω
		$V_{GS} = 5\text{V}, V_{DS} = 50\text{mV}, T_j = 225^\circ\text{C}$		0.65		Ω
Breakdown drain-to-source voltage ²	V_{BRDS}	$V_{GS} = 0\text{V}$	40			V

Dynamic Characteristics

 Unless otherwise stated, $T_j = 25^\circ\text{C}$. **Bold** figures point out values valid over the whole temperature range ($T_j = -55^\circ\text{C}$ to $+225^\circ\text{C}$).

Parameter	Symbol	Condition	Min	Typ	Max	Unit
Input capacitance	C_{ISS}	$V_{GS} = 0\text{V}_{DC}, DS$ shorted		370		pF
Output capacitance	C_{OSS}	$V_{GS} = 0\text{V}_{DC}, V_{DS} = 40\text{V}_{DC}$		50		pF
Feedback capacitance	C_{RSS}	$V_{GS} = 0\text{V}_{DC}, V_{DS} = 40\text{V}_{DC}$		21		pF
Gate to Source Charge	Q_{GS}	$V_{GS} = [0 \rightarrow 5]\text{V}; VD = 40\text{V}$		3.8		nC

Switching Characteristics

 Unless otherwise stated, $T_j = 25^\circ\text{C}$. **Bold** figures point out values valid over the whole temperature range ($T_j = -55^\circ\text{C}$ to $+225^\circ\text{C}$).

Parameter	Symbol	Condition	Min	Typ	Max	Unit
Turn-on delay time	$T_{d(ON)}$	$V_{DS} = 20\text{V}, V_{GS} = 5\text{V}$ 2 μs pulse, $R_G = 2.7\Omega, R_D = 8.2\Omega$		30		ns
Rise time	T_r	$V_{DS} = 20\text{V}, V_{GS} = 5\text{V}$ 2 μs pulse, $R_G = 2.7\Omega, R_D = 8.2\Omega$		50		ns
Turn-off delay time	$T_{d(OFF)}$	$V_{DS} = 20\text{V}, V_{GS} = 5\text{V}$ 2 μs pulse, $R_G = 2.7\Omega, R_D = 8.2\Omega$		35		ns
Fall time	T_f	$V_{DS} = 20\text{V}, V_{GS} = 5\text{V}$ 2 μs pulse, $R_G = 2.7\Omega, R_D = 8.2\Omega$		15		ns
Drain current	I_D	$V_{DS} = 40\text{V}, V_{GS} = 5\text{V}$ 2 μs pulse, -55°C		6.6		A
		$V_{DS} = 40\text{V}, V_{GS} = 5\text{V}$ 2 μs pulse, 25°C		5.7		A
		$V_{DS} = 40\text{V}, V_{GS} = 5\text{V}$ 2 μs pulse, 225°C		3.9		A

Thermal Characteristics

Parameter	Symbol	Condition	Min	Typ	Max	Unit
Thermal resistance (junction to air, CSOIC16)	Θ_{JA}			60		$^\circ\text{C/W}$

¹ Includes ESD diode leakage current.

² Voltage for which the cut-off current evolution versus V_{DS} becomes exponential.

Typical Performance Characteristics (per MOSFET)

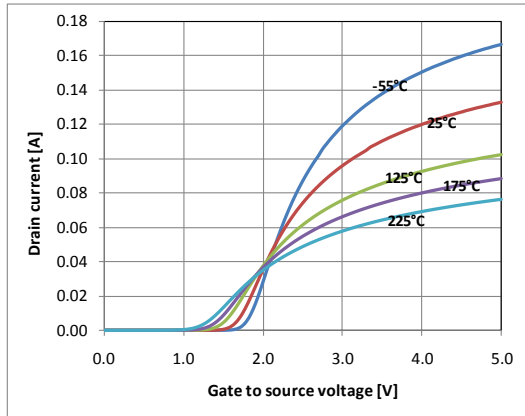

Drain current vs. gate voltage ($V_D = 50mV$)

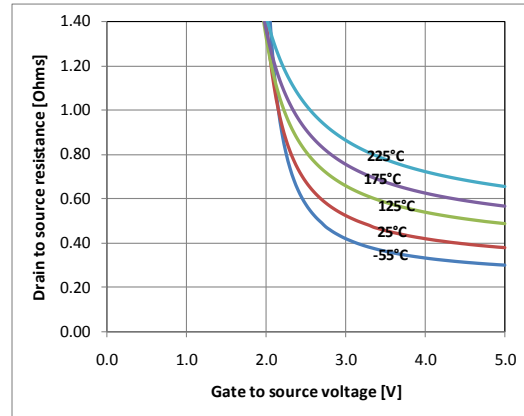

Drain source resistance vs. Drain source voltage ($V_D = 50mV$)

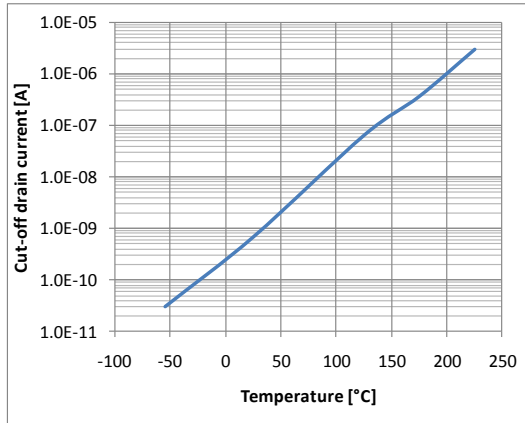

Cut-off current vs. temperature ($V_G = 0V, V_D = 40V$)

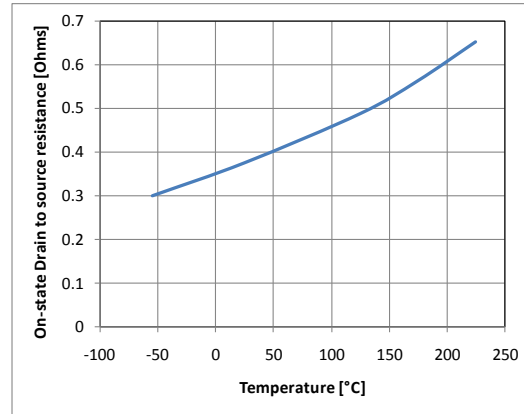

On-state drain source resistance vs. temperature ($V_G = 5V, V_D = 50mV$)

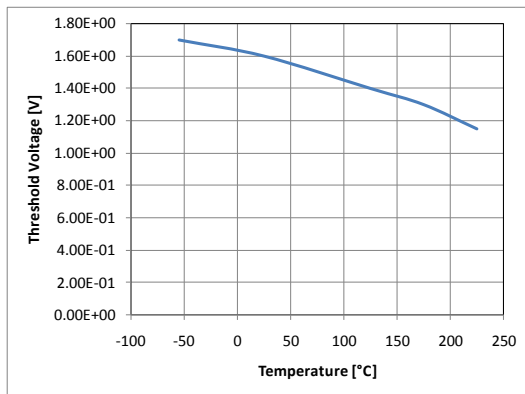

Threshold voltage vs. temperature

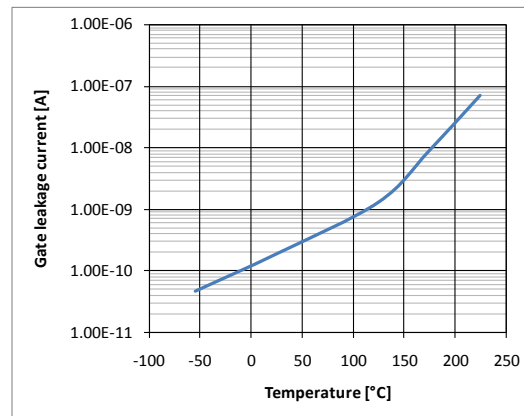

Gate and ESD diode leakage current vs. temperature ($V_G = 5V, V_D = 50mV$)

(Last Modification Date)

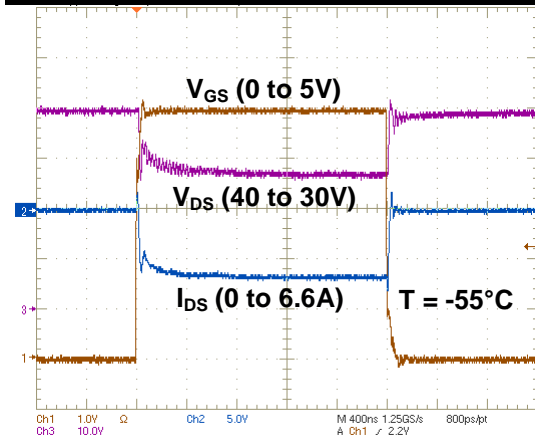

Maximum drain current pulse test (T = -55°C)

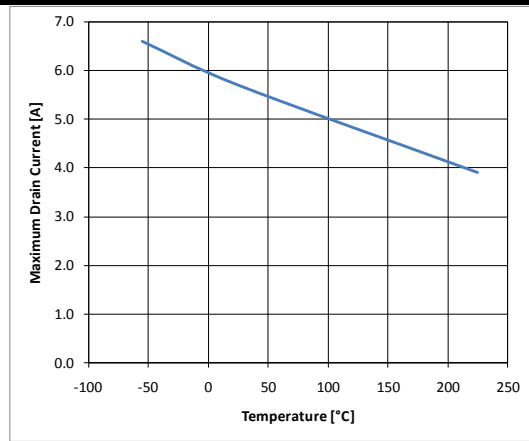

Peak drain current vs. temperature (V_G = 5V, V_D = 40V)

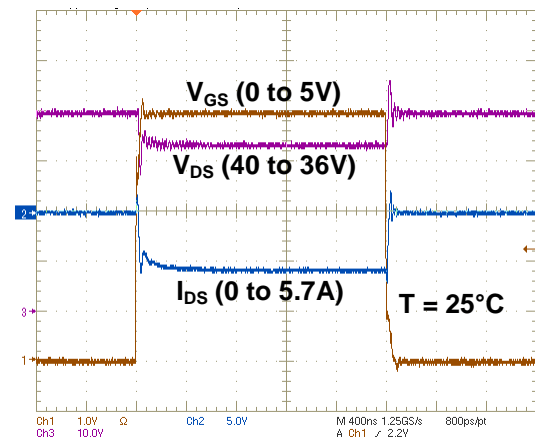

Maximum drain current pulse test (T = 25°C)

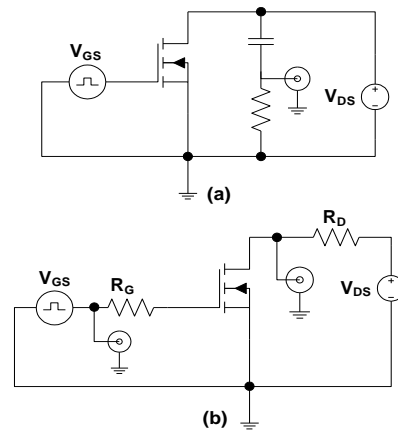

(a) I_D^{MAX} measurement scheme R=1Ω, C=100μF, Compliance (V_{DS}=40V)=20mA (b) Timing measurement scheme R_G=2.7Ω, R_D=8.2Ω, V_{DS}=20V

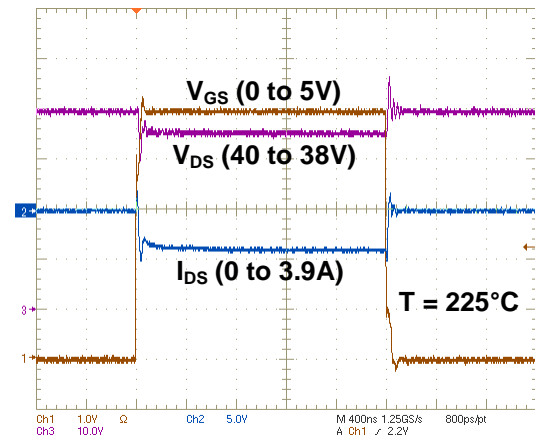

Maximum drain current pulse test (T = 225°C)

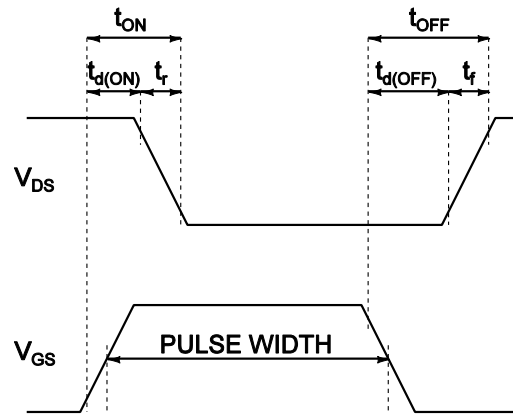

Timing definition diagram

**CHT-MOON- High-Temperature Medium Power
Dual N-channel MOSFET – DATASHEET**

(Last Modification Date)

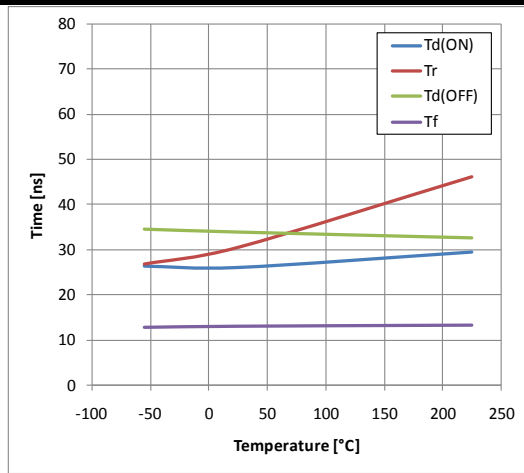

Timing parameters versus temperature

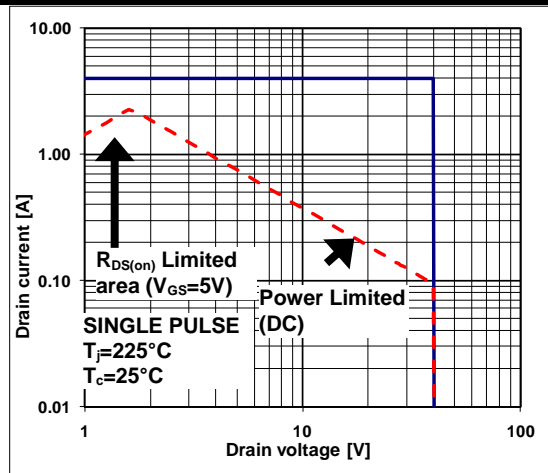

Forward bias safe operating area
(drain current = sum of drain current in both MOSFET devices)

General description
Applications

The 2 NMOS devices of CHT-MOON can be used in a variety of combinations. The figure below illustrates a few of them.

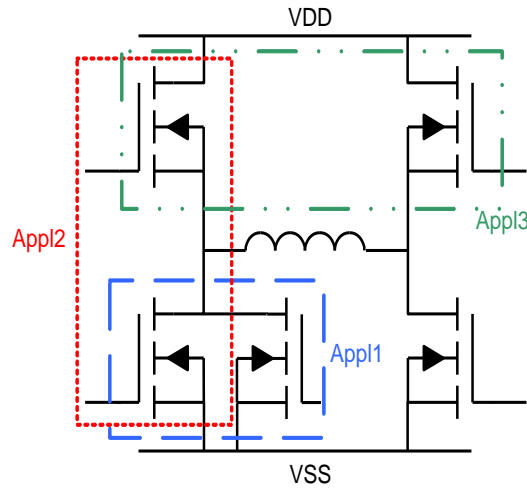

In Application1, the 2 NMOS are connected in parallel; this is useful for systems where Ron (and associated power dissipation) should be minimized

In Application2, the 2 NMOS form the push-pull stage of a half-bridge driver. This is the typical use case of a DC/DC synchronous buck converter.

In Application3, the 2 NMOS implement the high side of a bridge driver.

In all cases, FVSS signal should be connected to the lowest potential e.g. VSS.

(Last Modification Date)

Ordering Information

Ordering Reference	Package	Temperature Range	Marking
CHT-PLA2016A-CSOIC16-T	CSOIC16	-55°C to +225°C	CHT-PLA2016A

Package Drawing

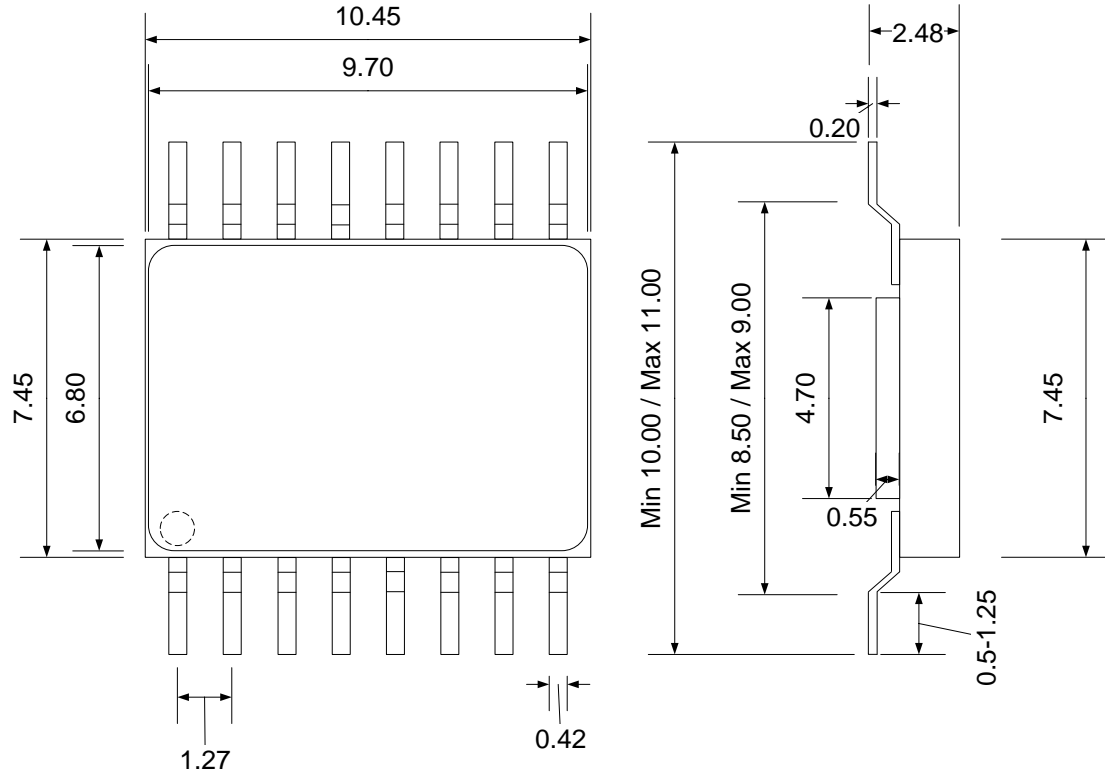

CSOIC 16 Drawing (mm +/- 10%)

(Last Modification Date)

Contact & Ordering**CISSOID S.A.**

Headquarters and contact EMEA:	CISSOID S.A. – Rue Francqui, 3 – 1435 Mont Saint Guibert - Belgium T : +32 10 48 92 10 - F: +32 10 88 98 75 Email: mailto:sales@cissoid.com
Sales Representatives:	Visit our website: http://www.cissoid.com/company/about-us/contacts.html

Disclaimer

Neither CISSOID, nor any of its directors, employees or affiliates make any representations or extend any warranties of any kind, either express or implied, including but not limited to warranties of merchantability, fitness for a particular purpose, and the absence of latent or other defects, whether or not discoverable. In no event shall CISSOID, its directors, employees and affiliates be liable for direct, indirect, special, incidental or consequential damages of any kind arising out of the use of its circuits and their documentation, even if they have been advised of the possibility of such a damage. The circuits are provided "as is". CISSOID has no obligation to provide maintenance, support, updates, or modifications.