

## 30-60GHz Frequency Multiplier GaAs Monolithic Microwave IC

### Description

The CHX2192-99F is a by 2 frequency multiplier monolithic circuit.

It is designed for a wide range of applications, from military to commercial communication systems. The backside of the chip is both RF and DC grounded. This simplifies the assembly process.

The circuit is manufactured with a pHEMT process, 0.15µm gate length, via holes through the substrate, air bridges and electron beam gate lithography. It is available in chip form.

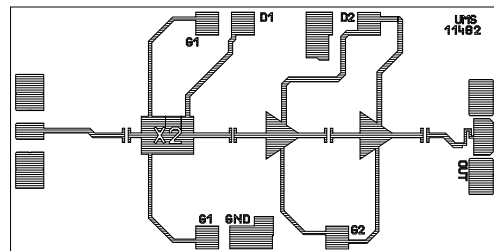

### Main Features

- Broadband performance: 27-33GHz
- 11dBm output power for +12dBm input
- DC consumption 130mA @3.5V (RF)
- Chip size: 2.12x1.11x0.10mm

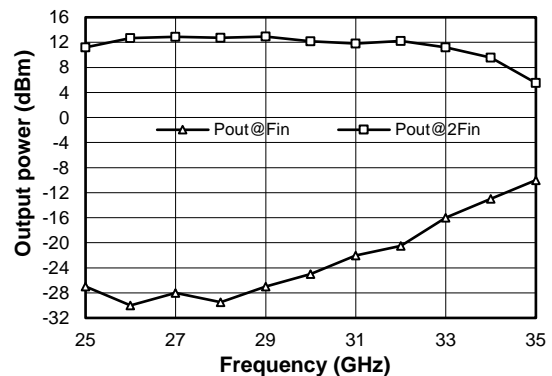

### Main Electrical Characteristics

Tamb.= +25°C

Symbol	Parameter	Min	Typ	Max	Unit
Fin	Input frequency range	27		33	GHz
Fout	Output frequency range	54		66	GHz
Pin	Input power		12		dBm
Pout	Output power for +12dBm input power	8	11	13	dBm

Caution: Electrostatic discharge sensitive device. Observe handling precautions!

## Electrical Characteristics

Tamb=+25°C, Vd=3.5V, Vg1=-0.9V, Vg2 adjusted for Id=130mA under RF

Symbol	Parameter	Min	Typ	Max	Unit
Fin	Input frequency range	27		33	GHz
Fout	Output frequency range	54		66	GHz
Pin	Input power		12		dBm
Pout	Output power for +12 dBm input power	8	11	13	dBm
Is/Fo	Fin level at the output ( 27 < Fin < 33GHz ), for +12dBm input power	-30	-15	-10	dBm
VSWRin	Input VSWR		2.5:1		
VSWRout	Output VSWR		2.5:1		
Id	Bias current		130		mA

A wire bond of typically 0.1 to 0.15nH will improve the input and output matching.

## Absolute Maximum Ratings <sup>(1)</sup>

Tamb=+25°C

Symbol	Parameter	Values	Unit
Vd	Drain bias voltage	4.0	V
Id	Drain bias current	150	mA
Ta	Operating temperature range	-40 to +95	°C
Tstg	Storage temperature range	-55 to +150	°C

(1) Operation of device above any one of these parameters may cause permanent damage.

## Typical on Wafer Measurements

Tamb=+25°C. Bias conditions: Vd=3.5V Vg1=-0.9V, Vg2 adjusted for Id=130mA under RF

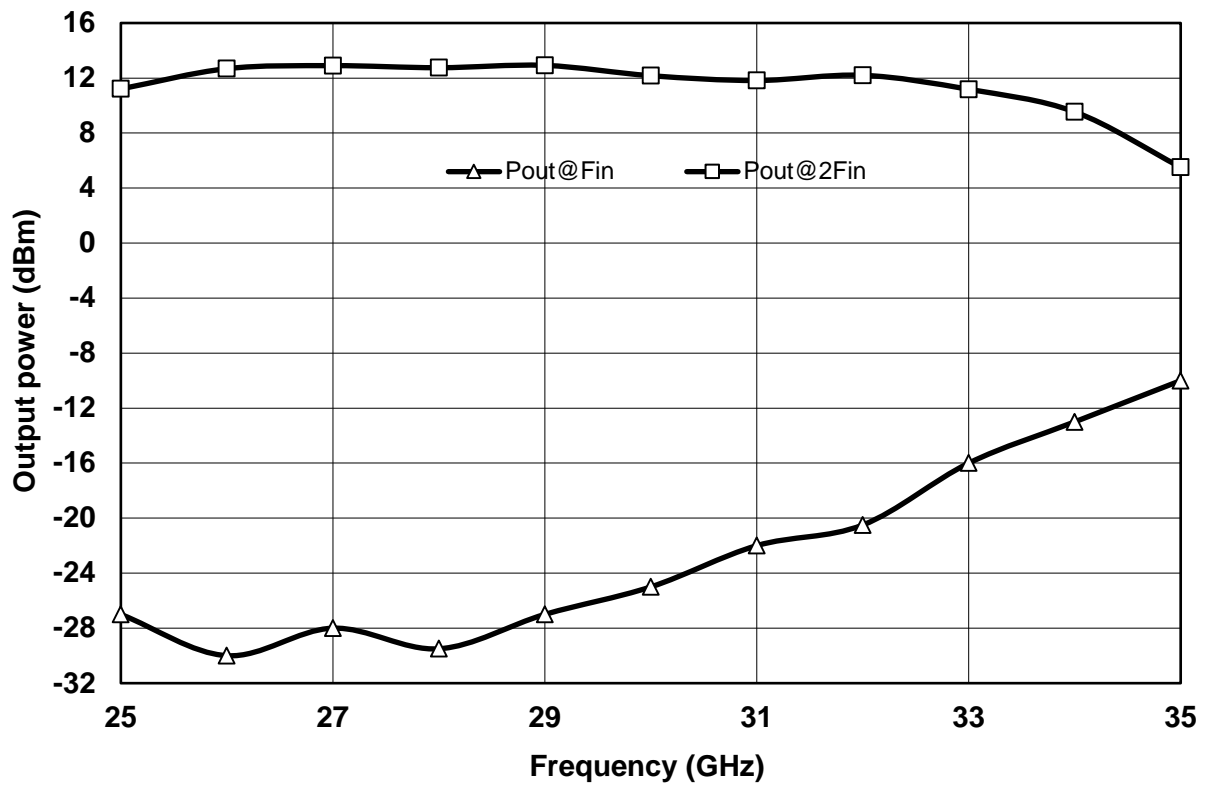

## Chip Assembly and Mechanical Data

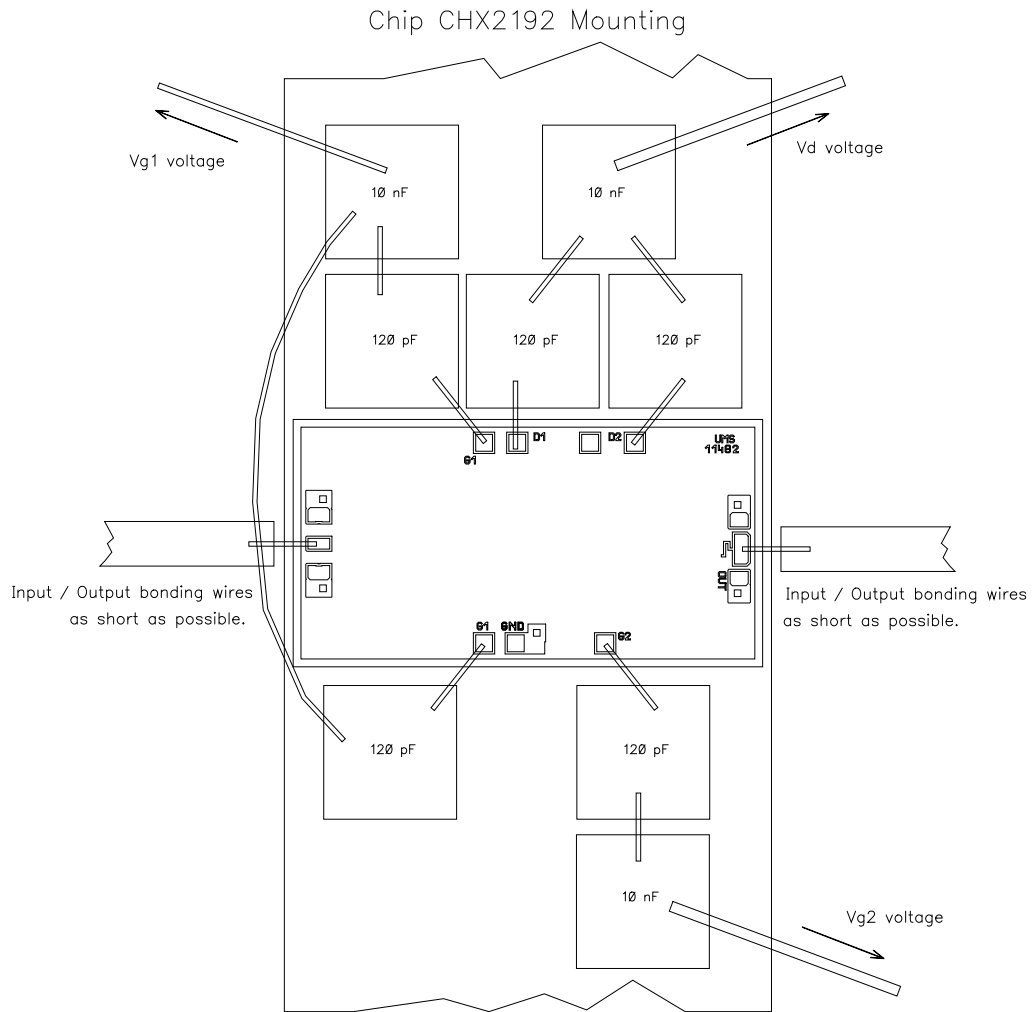

Note: Supply feed should be capacitively bypassed.  $25\mu\text{m}$  diameter gold wire is to be preferred.

**Chip Assembly and Mechanical Data**

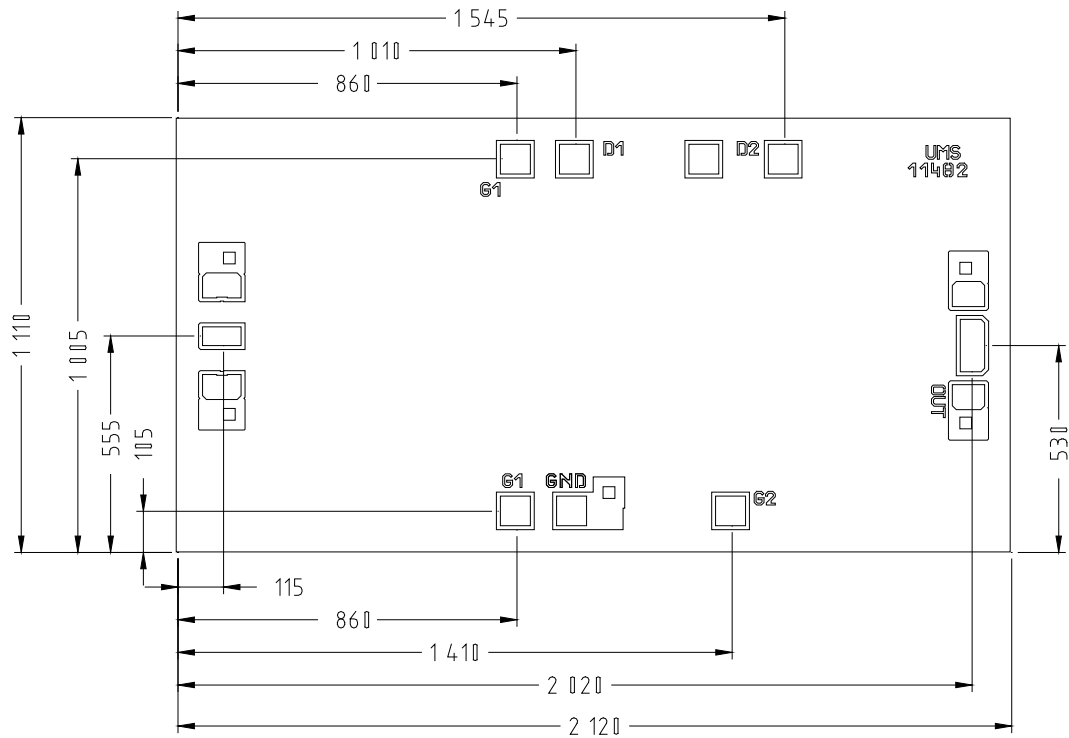

**Bonding pad positions**  
 (Chip thickness: 100μm. All dimensions are in micrometers)

## Recommended ESD management

Refer to the application note AN0020 available at <https://www.ums-rf.com> for ESD sensitivity and handling recommendations for the UMS products.

## Ordering Information

Chip form: CHX2192-99F/00

Information furnished is believed to be accurate and reliable. However **United Monolithic Semiconductors S.A.S.** assumes no responsibility for the consequences of use of such information nor for any infringement of patents or other rights of third parties which may result from its use. No license is granted by implication or otherwise under any patent or patent rights of **United Monolithic Semiconductors S.A.S.**. Specifications mentioned in this publication are subject to change without notice. This publication supersedes and replaces all information previously supplied. **United Monolithic Semiconductors S.A.S.** products are not authorised for use as critical components in life support devices or systems without express written approval from **United Monolithic Semiconductors S.A.S.**