



SOT-23 Plastic-Encapsulate MOSFETS

CJ2302S N-Channel 20-V(D-S) MOSFET

FEATURE

TrenchFET Power MOSFET

APPLICATIONS

- Load Switch for Portable Devices
- DC/DC Converter

MARKING: S2U

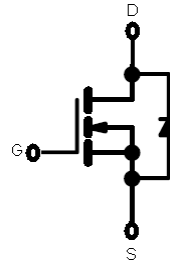
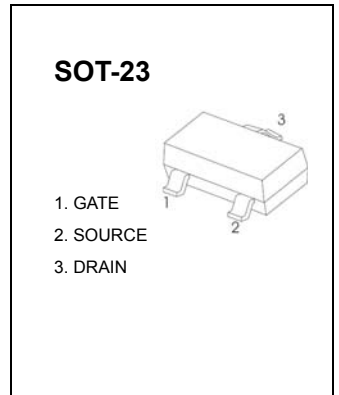

Maximum ratings (T_a=25°C unless otherwise noted)

Parameter	Symbol	Value	Unit
Drain-Source Voltage	V _{DS}	20	V
Gate-Source Voltage	V _{GS}	±8	
Continuous Drain Current (T _J =150°C)	I _D	2.1	A
Pulsed Drain Current	I _{DM}	10	
Continuous Source-Drain Current(Diode Conduction)	I _S	0.6	
Power Dissipation	P _D	0.35	W
Thermal Resistance from Junction to Ambient (t≤5s)	R _{θJA}	357	°C/W
Operating Junction	T _J	150	°C
Storage Temperature	T _{STG}	-55 ~+150	

Electrical characteristics (T_a=25°C unless otherwise noted)

Parameter	Symbol	Test Condition	Min	Typ	Max	Units
Static						
Drain-source breakdown voltage	V _{(BR)DSS}	V _{GS} = 0V, I _D = 10μA	20			V
Gate-threshold voltage	V _{GS(th)}	V _{DS} = V _{GS} , I _D = 50μA	0.65	0.95	1.2	
Gate-body leakage	I _{GSS}	V _{DS} = 0V, V _{GS} = ±8V			±100	nA
Zero gate voltage drain current	I _{DSS}	V _{DS} = 20V, V _{GS} = 0V			1	μA
Drain-source on-resistance ^a	r _{DS(on)}	V _{GS} = 4.5V, I _D = 3.6A		0.045	0.060	Ω
		V _{GS} = 2.5V, I _D = 3.1A		0.070	0.115	
Forward transconductance ^a	g _{fs}	V _{DS} = 5V, I _D = 3.6A		8		S
Diode forward voltage	V _{SD}	I _S = 0.94A, V _{GS} = 0V		0.76	1.2	V
Dynamic						
Total gate charge	Q _g	V _{DS} = 10V, V _{GS} = 4.5V, I _D = 3.6A		4.0	10	nC
Gate-source charge	Q _{gs}			0.65		
Gate-drain charge	Q _{gd}			1.5		
Input capacitance	C _{iss}	V _{DS} = 10V, V _{GS} = 0V, f = 1MHz		300		pF
Output capacitance	C _{oss}			120		
Reverse transfer capacitance	C _{rss}			80		
Switching						
Turn-on delay time	t _{d(on)}	V _{DD} = 10V, R _L = 5.5Ω, I _D ≈ 3.6A, V _{GEN} = 4.5V, R _g = 6Ω		7	15	ns
Rise time	t _r			55	80	
Turn-off delay time	t _{d(off)}			16	60	
Fall time	t _f			10	25	

Notes :

a. Pulse Test : Pulse width ≤ 300μs, duty cycle ≤ 2%.

Typical Characteristics

CJ2302S

