

**CJ7815F** Three-terminal positive voltage regulator

**FEATURES**

- Maximum output current  
 $I_{OM}: 1.5\text{ A}$
- Output voltage  
 $V_O: 15\text{ V}$
- Continuous total dissipation  
 $P_D: 1.5\text{ W}$  ( $T_a = 25\text{ }^\circ\text{C}$ )

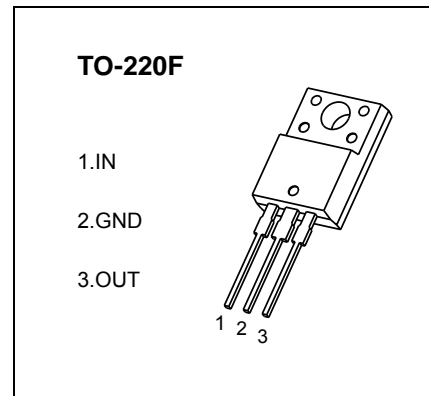

**ABSOLUTE MAXIMUM RATINGS (Operating temperature range applies unless otherwise specified)**

Parameter	Symbol	Value	Unit
Input Voltage	$V_i$	35	V
Thermal Resistance from Junction to Ambient	$R_{\theta JA}$	66.7	$^\circ\text{C/W}$
Operating Junction Temperature Range	$T_{OPR}$	-25~+125	$^\circ\text{C}$
Storage Temperature Range	$T_{STG}$	-65~+150	$^\circ\text{C}$

**ELECTRICAL CHARACTERISTICS AT SPECIFIED VIRTUAL JUNCTION TEMPERATURE ( $V_i=23\text{V}, I_o=500\text{mA}, C_i=0.33\mu\text{F}, C_o=0.1\mu\text{F}$ , unless otherwise specified)**

Parameter	Symbol	Test conditions	MIN	TYP	MAX	UNIT
Output voltage	$V_o$	$25\text{ }^\circ\text{C}$	14.4	15	15.6	V
		$17.5\text{V} \leq V_i \leq 30\text{V}, I_o=5\text{mA}-1\text{A}$ $-25\text{ }^\circ\text{C}$	14.25	15	15.75	V
Load Regulation	$\Delta V_o$	$I_o=5\text{mA}-1.5\text{A}$ $25\text{ }^\circ\text{C}$		12	300	mV
		$I_o=250\text{mA}-750\text{mA}$ $25\text{ }^\circ\text{C}$		4	150	mV
Line regulation	$\Delta V_o$	$17.5\text{V} \leq V_i \leq 30\text{V}$ $25\text{ }^\circ\text{C}$		12	300	mV
		$20\text{V} \leq V_i \leq 26\text{V}$ $25\text{ }^\circ\text{C}$		3	150	mV
Quiescent Current	$I_q$	$25\text{ }^\circ\text{C}$		4.3	8	mA
Quiescent Current Change	$\Delta I_q$	$17.5\text{V} \leq V_i \leq 30\text{V}$ $-25\text{ }^\circ\text{C}$			1	mA
		$5\text{mA} \leq I_o \leq 1\text{A}$			0.5	mA
Output voltage drift	$\Delta V_o / \Delta T$	$I_o=5\text{mA}$ $-25\text{ }^\circ\text{C}$		-1		$\text{mV}/^\circ\text{C}$
Output Noise Voltage	$V_N$	$10\text{Hz} \leq f \leq 100\text{KHz}$ $25\text{ }^\circ\text{C}$		90		$\mu\text{V}/V_o$
Ripple Rejection	RR	$18.5\text{V} \leq V_i \leq 28.5\text{V}, f=120\text{Hz}$ $-25\text{ }^\circ\text{C}$	54	70		dB
Dropout Voltage	$V_d$	$I_o=1\text{A}$ $25\text{ }^\circ\text{C}$		2		V
Output resistance	$R_o$	$f=1\text{KHz}$ $25\text{ }^\circ\text{C}$		19		$\text{m}\Omega$
Short Circuit Current	$I_{sc}$	$25\text{ }^\circ\text{C}$		230		mA
Peak Current	$I_{pk}$	$25\text{ }^\circ\text{C}$		2.1		A

\* Pulse test.

**TYPICAL APPLICATION**

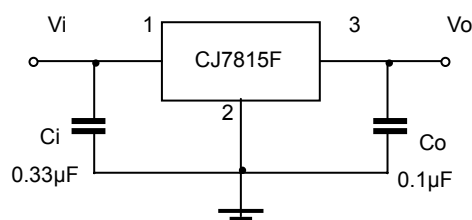

Note: Bypass capacitors are recommended for optimum stability and transient response and should be located as close as possible to the regulators.

# Typical Characteristics

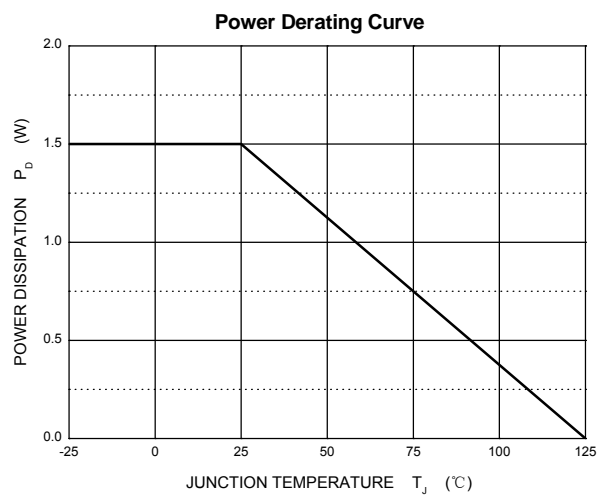
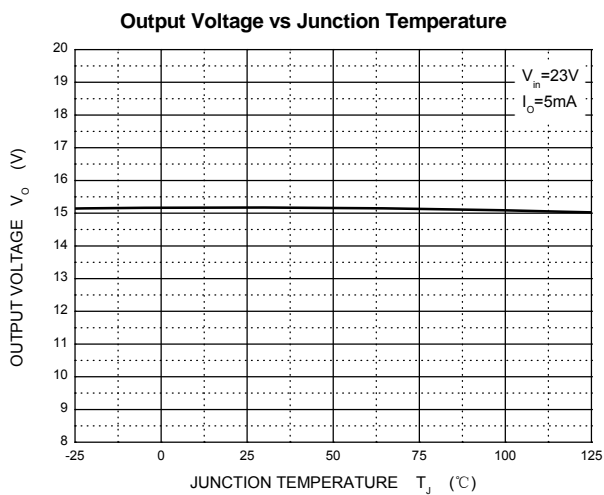
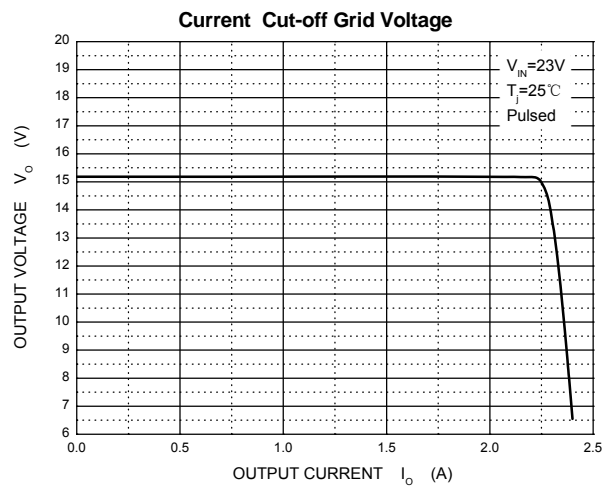
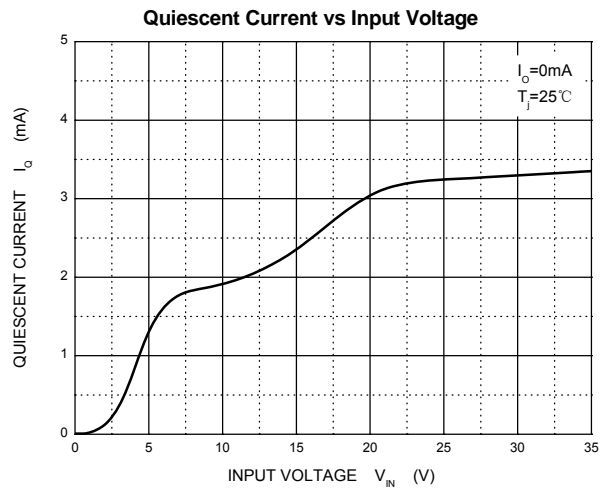
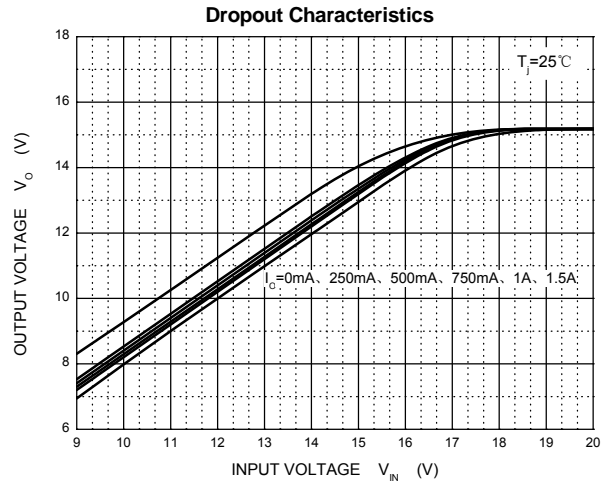
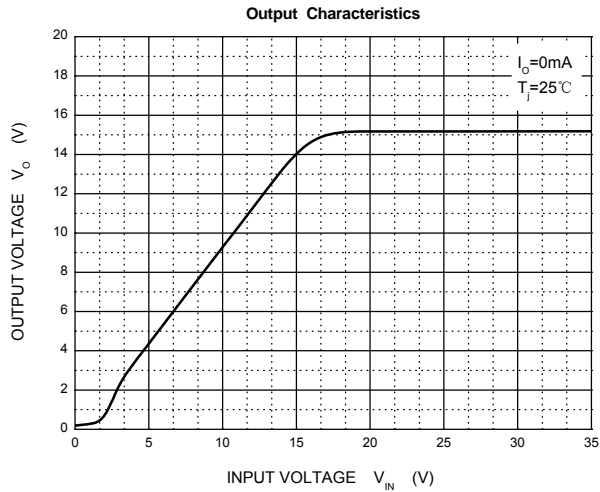

# TO-220F Package Outline Dimensions

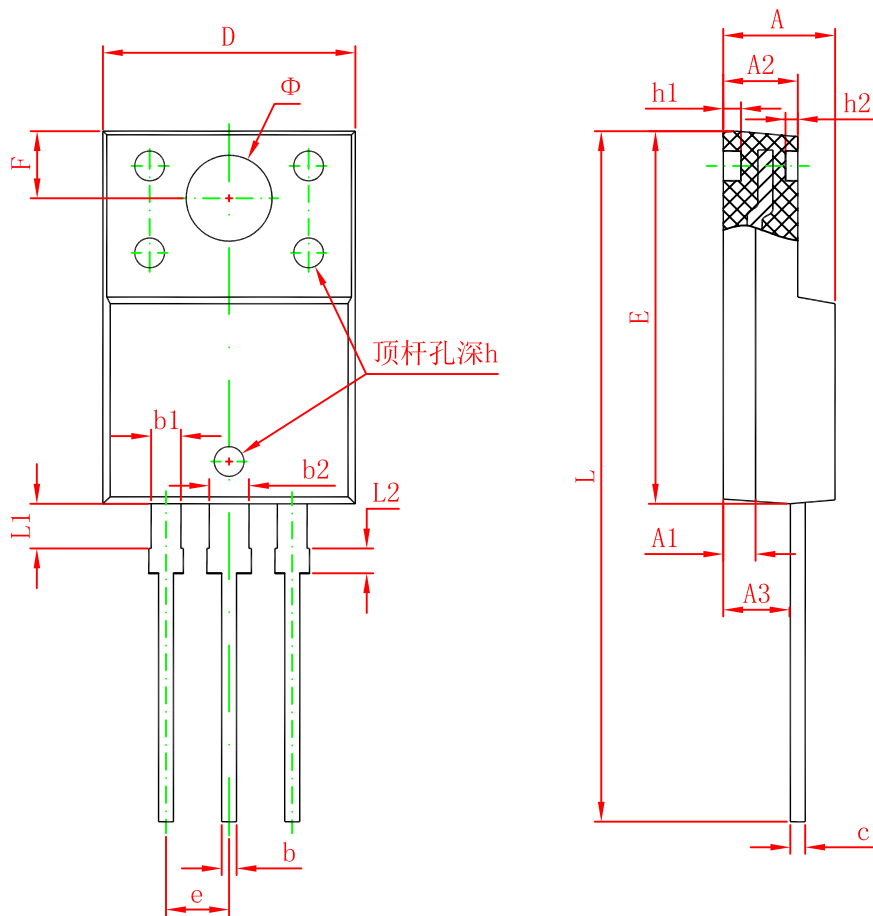

Symbol	Dimensions In Millimeters		Dimensions In Inches	
	Min.	Max.	Min.	Max.
A	4.300	4.700	0.169	0.185
A1	1.300 REF.		0.051 REF.	
A2	2.800	3.200	0.110	0.126
A3	2.500	2.900	0.098	0.114
b	0.500	0.750	0.020	0.030
b1	1.100	1.350	0.043	0.053
b2	1.500	1.750	0.059	0.069
c	0.500	0.750	0.020	0.030
D	9.960	10.360	0.392	0.408
E	14.800	15.200	0.583	0.598
e	2.540 TYP.		0.100 TYP.	
F	2.700 REF.		0.106 REF.	
Φ	3.500 REF.		0.138 REF.	
h	0.000	0.300	0.000	0.012
h1	0.800 REF.		0.031 REF.	
h2	0.500 REF.		0.020 REF.	
L	28.000	28.400	1.102	1.118
L1	1.700	1.900	0.067	0.075
L2	0.900	1.100	0.035	0.043