

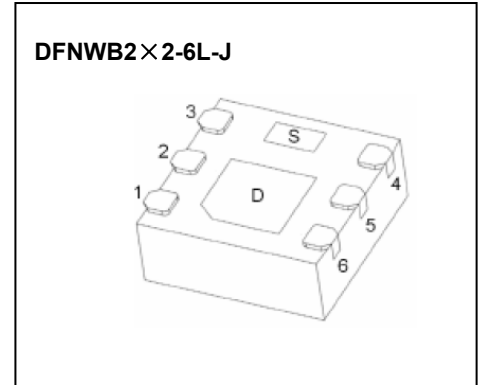

**DFNWB2X2-6L-J Plastic-Encapsulate MOSFETS**

**CJM1208** P-Channel MOSFET

V <sub>(BR)DSS</sub>	R <sub>DS(on)MAX</sub>	I <sub>D</sub>
-12V	28mΩ@-4.5V	-8A
	32mΩ@-3.7V	
	40mΩ@-2.5V	
	63mΩ@-1.8V	
	150mΩ@-1.5V	



**FEATURE**

- Advanced trench MOSFET process technology
- Ultra low on-resistance with low gate charge

**APPLICATION**

- PWM application
- Load switch
- Battery charge in cellular handset

**MARKING:**

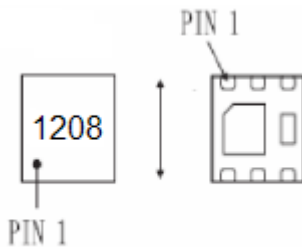

**Equivalent Circuit**

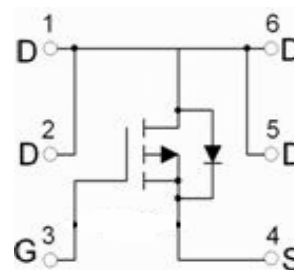

**ABSOLUTE MAXIMUM RATINGS (T<sub>a</sub>=25°C unless otherwise noted)**

Parameter	Symbol	Value	Unit
Drain-Source Voltage	V <sub>DS</sub>	-12	V
Gate-Source Voltage	V <sub>GS</sub>	±8	
Drain Current-Continuous	I <sub>D</sub>	-8	A
Drain Current-Pulsed	I <sub>DM</sub> *	-28	
Thermal Resistance from Junction to Ambient	R <sub>θJA</sub>	357	°C/W
Junction Temperature	T <sub>j</sub>	150	°C
Storage Temperature	T <sub>STG</sub>	-55 ~+150	

\*Repetitive rating: Pulse width limited by junction temperature.

## MOSFET ELECTRICAL CHARACTERISTICS

$T_a=25\text{ }^\circ\text{C}$  unless otherwise specified

Parameter	Symbol	Test Condition	Min	Typ	Max	Unit
<b>Static Characteristics</b>						
Drain-source breakdown voltage	$V_{(BR)DSS}$	$V_{GS} = 0V, I_D = -250\mu A$	-12			V
Zero gate voltage drain current	$I_{DSS}$	$V_{DS} = -12V, V_{GS} = 0V$			-1	$\mu A$
Gate-body leakage current	$I_{GSS}$	$V_{GS} = \pm 8V, V_{DS} = 0V$			$\pm 0.1$	$\mu A$
Gate threshold voltage (note 1)	$V_{GS(th)}$	$V_{DS} = V_{GS}, I_D = -250\mu A$	-0.4		-1	V
Drain-source on-resistance (note 1)	$R_{DS(on)}$	$V_{GS} = -4.5V, I_D = -5A$			28	m $\Omega$
		$V_{GS} = -3.7V, I_D = -4.6A$			32	
		$V_{GS} = -2.5V, I_D = -4.3A$			40	
		$V_{GS} = -1.8V, I_D = -1A$			63	
		$V_{GS} = -1.5V, I_D = -0.5A$			150	
Forward transconductance (note 1)	$g_{FS}$	$V_{DS} = -5V, I_D = -5A$		18		S
<b>Dynamic characteristics (note 2)</b>						
Input Capacitance	$C_{iss}$	$V_{DS} = -6V, V_{GS} = 0V, f = 1MHz$		1275		pF
Output Capacitance	$C_{oss}$			255		pF
Reverse Transfer Capacitance	$C_{rss}$			236		pF
Gate resistance	$R_g$	$f = 1MHz$	1.9		19	$\Omega$
Total Gate Charge	$Q_g$	$V_{DS} = -6V, V_{GS} = -4.5V, I_D = -5A$		14	21	nC
Gate-Source Charge	$Q_{gs}$			2.3		nC
Gate-Drain Charge	$Q_{gd}$			3.6		nC
Turn-on delay time	$t_{d(on)}$	$V_{DD} = -6V, V_{GEN} = -4.5V, I_D = -4A$ $R_L = 6\Omega, R_{GEN} = 1\Omega$		26	40	ns
Turn-on rise time	$t_r$			24	40	ns
Turn-off delay time	$t_{d(off)}$			45	70	ns
Turn-off fall time	$t_f$			20	35	ns
<b>Source-Drain Diode characteristics</b>						
Diode forward current	$I_S$				-8	A
Diode pulsed forward current	$I_{SM}$				-28	A
Diode Forward voltage (note 1)	$V_{DS}$	$V_{GS} = 0V, I_S = -4A$			-1.2	V
Diode reverse recovery time (note 2)	$t_{rr}$	$I_F = -4A, di/dt = 100A/\mu s$		24	48	ns
Diode reverse recovery charge (note 2)	$Q_{rr}$			8	16	nC

**Notes :** 1. Pulse test; pulse width  $\leq 300\mu s$ , duty cycle  $\leq 2\%$ .

# Typical Characteristics

Output Characteristics

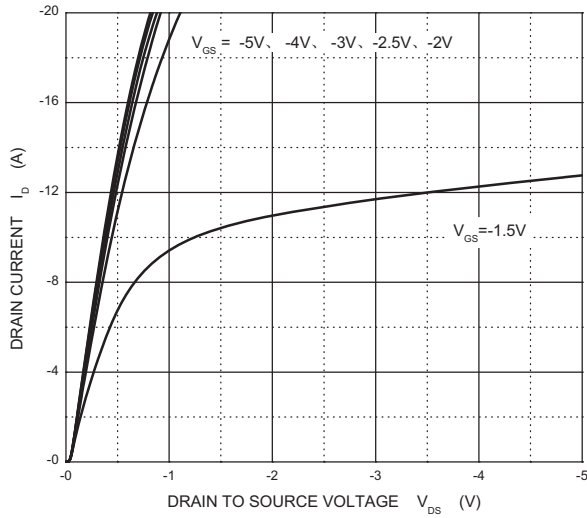

Transfer Characteristics

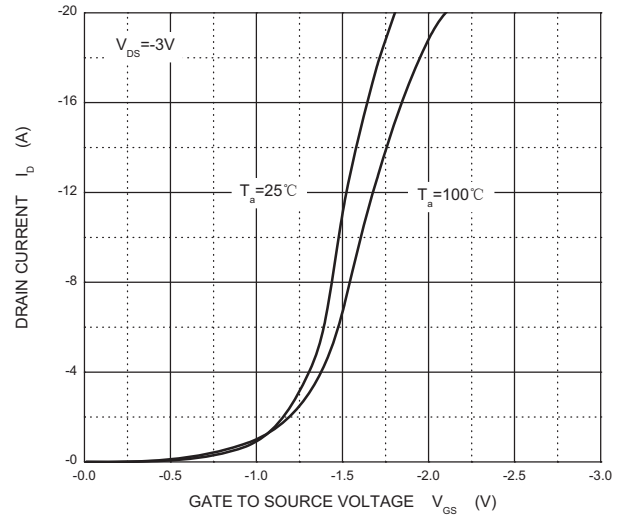

$R_{DS(ON)}$  —  $I_D$

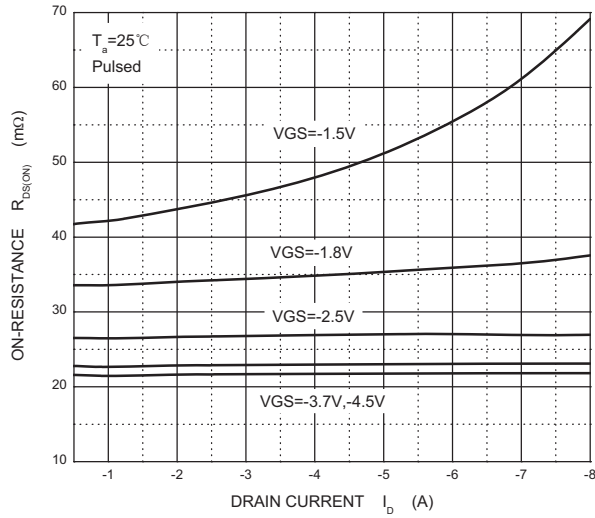

$R_{DS(ON)}$  —  $V_{GS}$

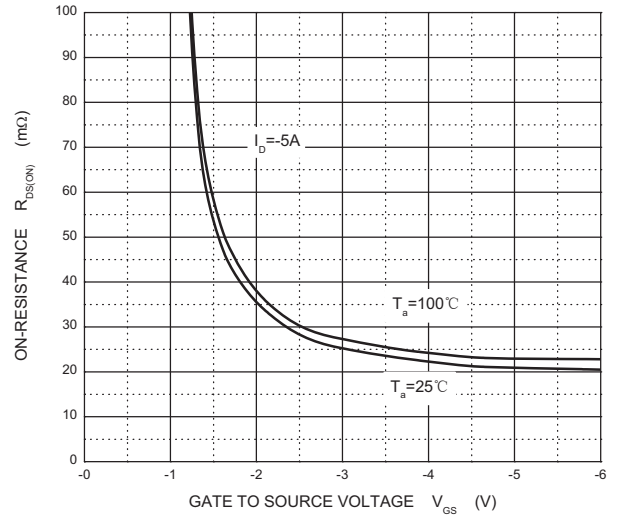

$I_S$  —  $V_{SD}$

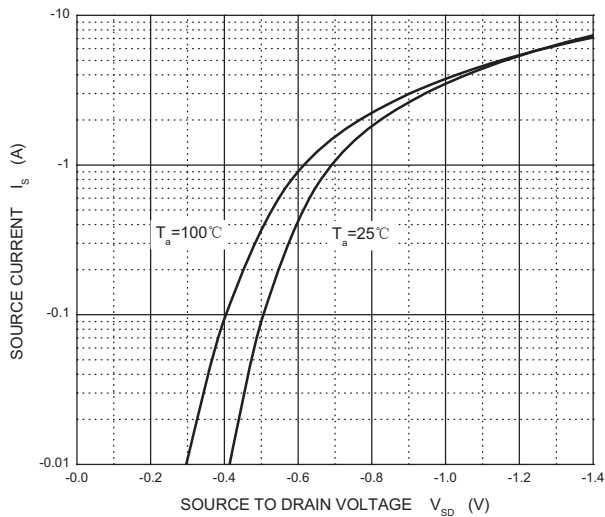

Threshold Voltage

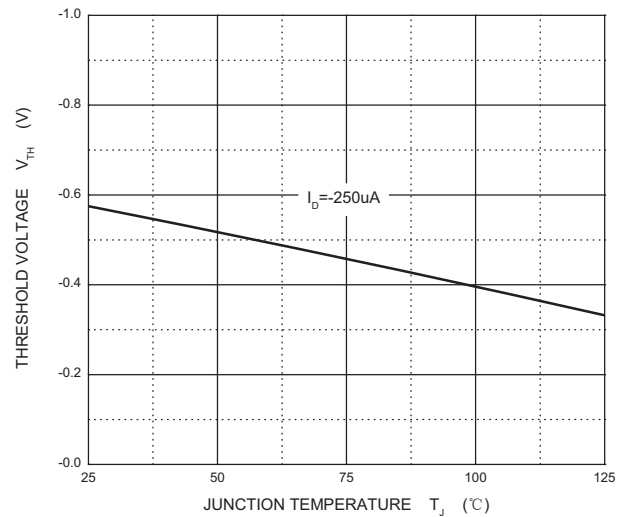

## DFNWB2X2-6L-J Package Outline Dimensions

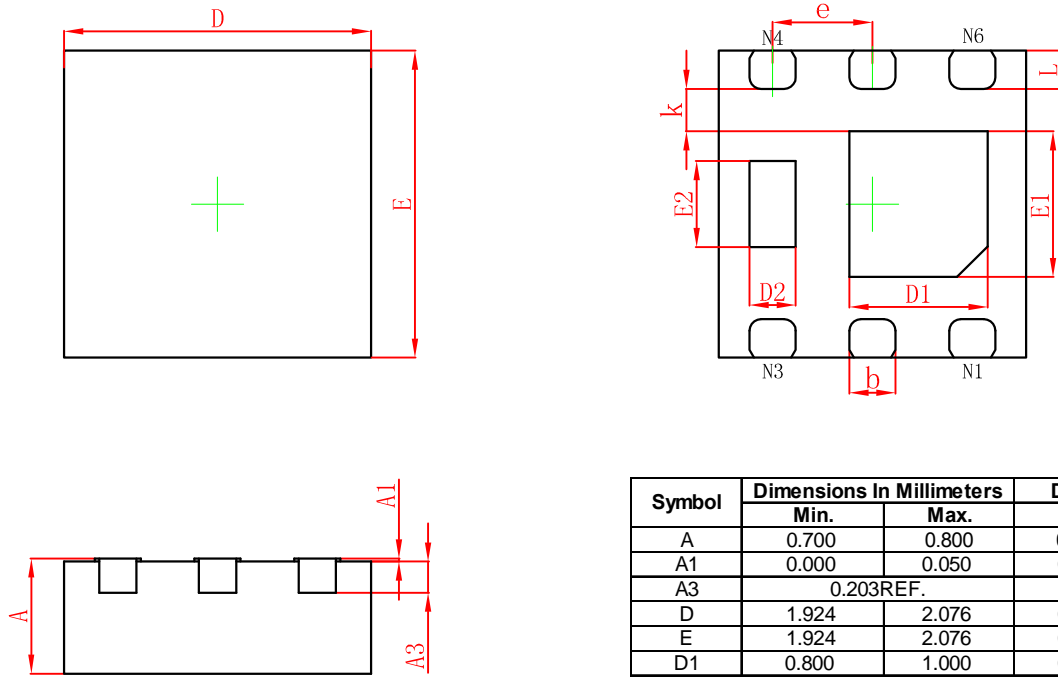

Symbol	Dimensions In Millimeters		Dimensions In Inches	
	Min.	Max.	Min.	Max.
A	0.700	0.800	0.028	0.032
A1	0.000	0.050	0.000	0.002
A3	0.203REF.		0.008REF.	
D	1.924	2.076	0.076	0.082
E	1.924	2.076	0.076	0.082
D1	0.800	1.000	0.031	0.039
E1	0.850	1.050	0.033	0.041
D2	0.200	0.400	0.008	0.016
E2	0.460	0.660	0.018	0.026
k	0.200MIN.		0.008MIN.	
b	0.250	0.350	0.010	0.014
e	0.650TYP.		0.026TYP.	
L	0.174	0.326	0.007	0.013

## DFNWB2X2-6L-J Suggested Pad Layout

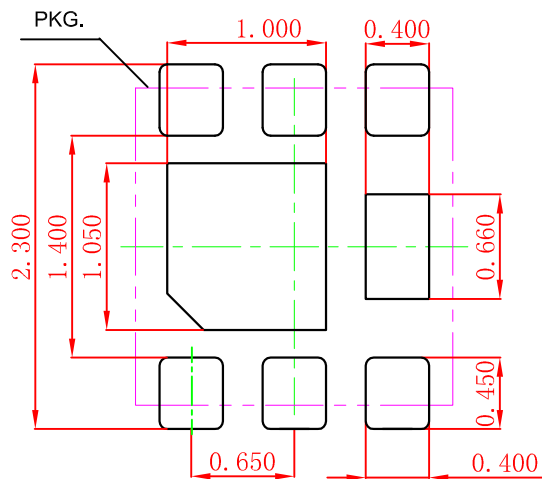

**Note:**

1. Controlling dimension: in millimeters.
2. General tolerance:  $\pm 0.050\text{mm}$ .
3. The pad layout is for reference purposes only.

**NOTICE**

JCET reserve the right to make modifications, enhancements, improvements, corrections or other changes without further notice to any product herein. JCET does not assume any liability arising out of the application or use of any product described herein.

# DFNWB2X2-6L Tape and Reel

## DFNWB2×2-6L Embossed Carrier Tape

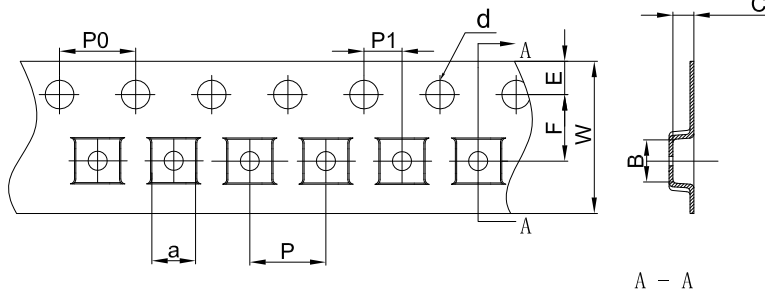

### Packaging Description:

DFNWB2×2-6L parts are shipped in tape. The carrier tape is made from a dissipative (carbon filled) polycarbonate resin. The cover tape is a multilayer film (Heat Activated Adhesive in nature) primarily composed of polyester film, adhesive layer, sealant, and anti-static sprayed agent. These reeled parts in standard option are shipped with 3,000 units per 7" or 18.0cm diameter reel. The reels are clear in color and is made of polystyrene plastic (anti-static coated).

Dimensions are in millimeter

Pkg type	a	B	C	d	E	F	P0	P	P1	W
DFNWB2×2-6L	2.30	2.30	1.10	Ø1.50	1.75	3.50	4.00	4.00	2.00	8.00

## DFNWB2×2-6L Tape Leader and Trailer

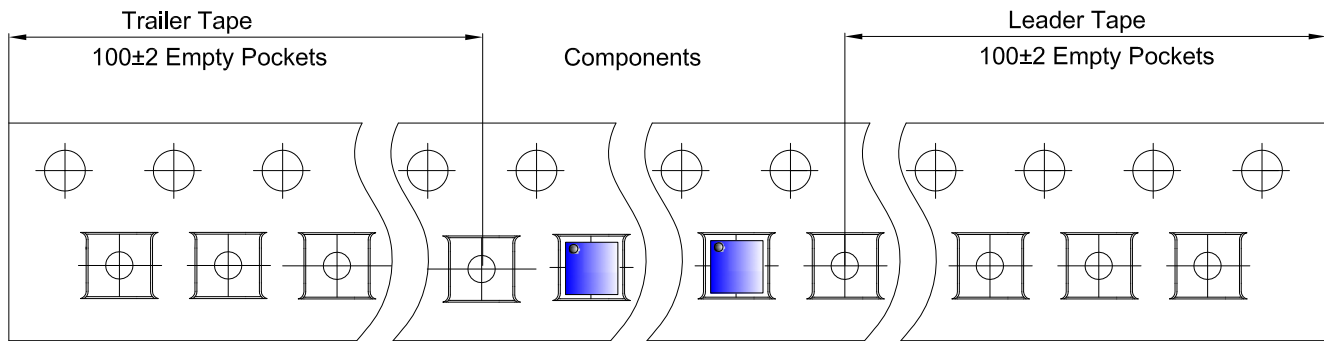

## DFNWB2×2-6L Reel

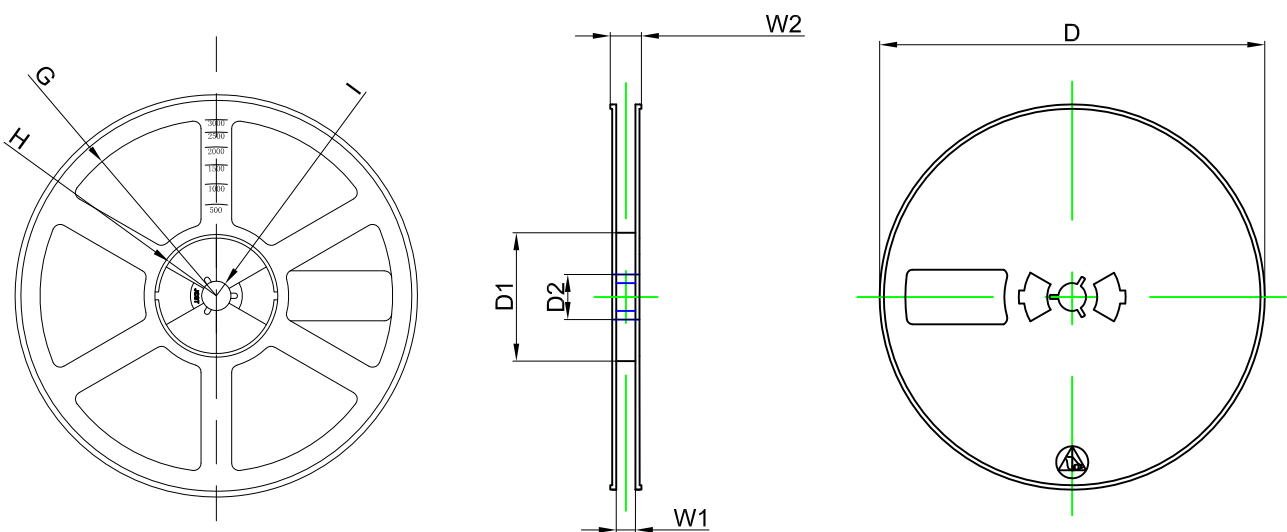

Dimensions are in millimeter

Reel Option	D	D1	D2	G	H	I	W1	W2
7" Dia	Ø180.00	60.00	13.00	R78.00	R25.60	R6.50	9.50	13.10

REEL	Reel Size	Box	Box Size(mm)	Carton	Carton Size(mm)	G.W.(kg)
3000 pcs	7 inch	30,000 pcs	203×203×195	120,000 pcs	438×438×220	