

TO-220-3L Plastic-Encapsulate MOSFETS

CJP05N60B N-Channel Power MOSFET

$V_{(BR)DSS}$	$R_{DS(on)MAX}$	I_D
600V	2.5Ω@10V	5A

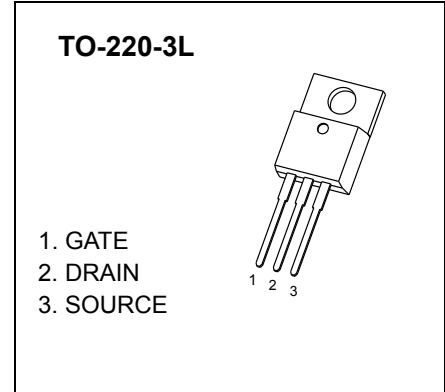

GENERAL DESCRIPTION

This advanced high voltage MOSFET is designed to stand high energy in the avalanche mode and switch efficiently. This new recovery time. Designed for high voltage, high speed switching high energy device also offers a drain-to-source diode fast applications such as power supplies, converters, power motor controls and bridge circuits.

FEATURE

- High Current Rating
- Lower $R_{DS(on)}$
- Lower Capacitance
- Lower Total Gate Charge
- Tighter V_{SD} Specifications
- Avalanche Energy Specified

MARKING



CJP05N60B= Device code
Solid dot = Green molding compound device,
if none, the normal device
XXX=Date Code

EQUIVALENT CIRCUIT

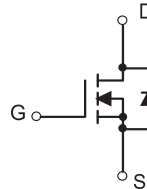

Maximum ratings ($T_a=25^\circ\text{C}$ unless otherwise noted)

Parameter	Symbol	Value	Unit
Drain-Source Voltage	V_{DS}	600	V
Gate-Source Voltage	V_{GS}	±30	
Continuous Drain Current	I_D	5	A
Pulsed Drain Current	I_{DM}	20	
Single Pulsed Avalanche Energy (note1)	E_{AS}	250	mJ
Thermal Resistance from Junction to Ambient	$R_{\theta JA}$	62.5	°C/W
Junction Temperature	T_J	150	°C
Storage Temperature Range	T_{STG}	-55 ~+150	
Maximum lead temperature for soldering purposes , Duration 5 seconds	T_L	260	

MOSFET ELECTRICAL CHARACTERISTICS

$T_a=25^\circ\text{C}$ unless otherwise specified

Parameter	Symbol	Test Condition	Min	Typ	Max	Unit
Off characteristics						
Drain-source breakdown voltage	$V_{(BR)DSS}$	$V_{GS} = 0V, I_D = 250\mu A$	600			V
Drain-source diode forward voltage(note2)	V_{SD}	$V_{GS} = 0V, I_S = 4.5A$			1.4	
Zero gate voltage drain current	I_{DSS}	$V_{DS} = 600V, V_{GS} = 0V$			1	μA
Gate-body leakage curren (note2)	I_{GSS}	$V_{DS} = 0V, V_{GS} = \pm 30V$			± 100	nA
On characteristics (note2)						
Gate-threshold voltage	$V_{GS(th)}$	$V_{DS} = V_{GS}, I_D = 250\mu A$	2.0	3.5	4.0	V
Static drain-source on-resistance	$R_{DS(on)}$	$V_{GS} = 10V, I_D = 2.25A$		2.0	2.5	Ω
Dynamic characteristics (note 3)						
Input capacitance	C_{iss}	$V_{DS} = 25V, V_{GS} = 0V, f = 1MHz$			670	pF
Output capacitance	C_{oss}				72	
Reverse transfer capacitance	C_{rss}				8.5	
Switching characteristics (note 3)						
Turn-on delay time	$t_{d(on)}$	$V_{DD} = 300V, V_{GS} = 10V,$ $R_G = 25\Omega, I_D = 4.5A$			30	ns
Turn-on rise time	t_r				90	
Turn-off delay time	$t_{d(off)}$				85	
Turn-off fall time	t_f				100	

Notes :

1. $L=16mH, I_L=5A, V_{DD}=50V, R_G=25\Omega, \text{Starting } T_J=25^\circ\text{C}.$
2. Pulse Test : Pulse width $\leq 300\mu s,$ duty cycle $\leq 2\%.$
3. These parameters have no way to verify.

Typical Characteristics

Output Characteristics

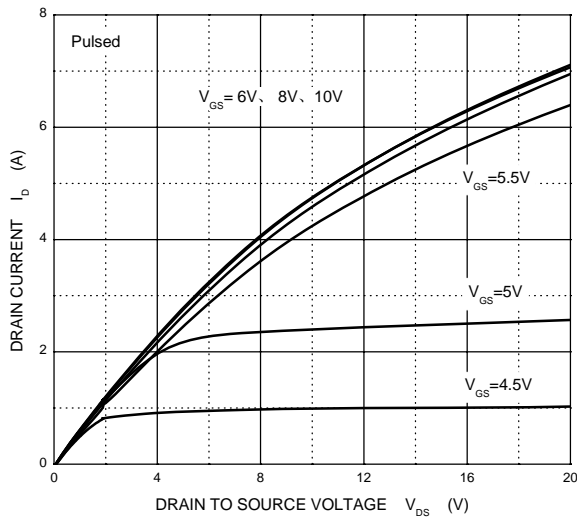

Transfer Characteristics

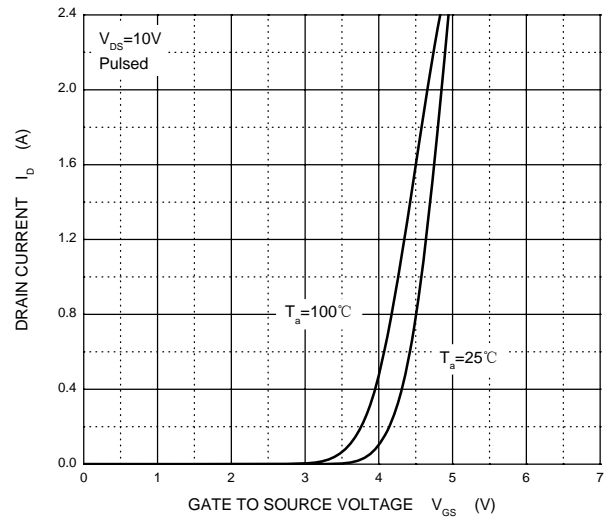

$R_{DS(ON)}$ — I_D

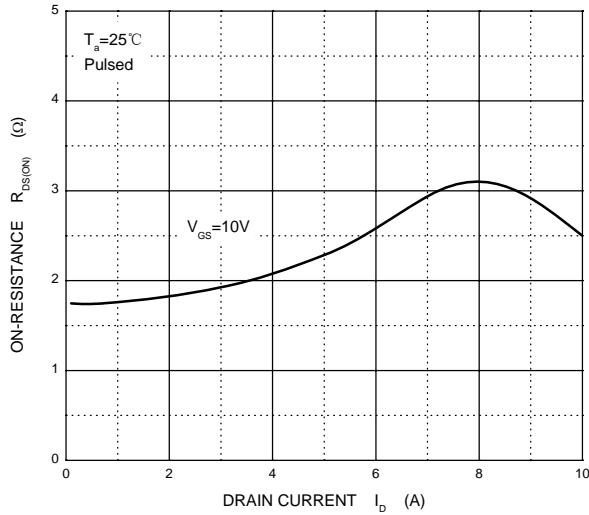

$R_{DS(ON)}$ — V_{GS}

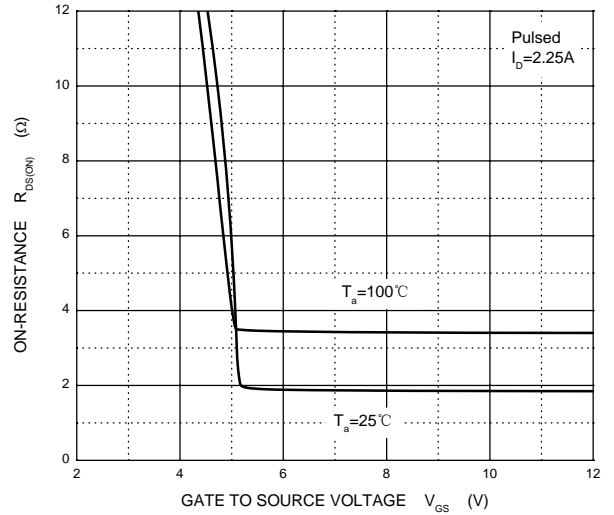

I_S — V_{SD}

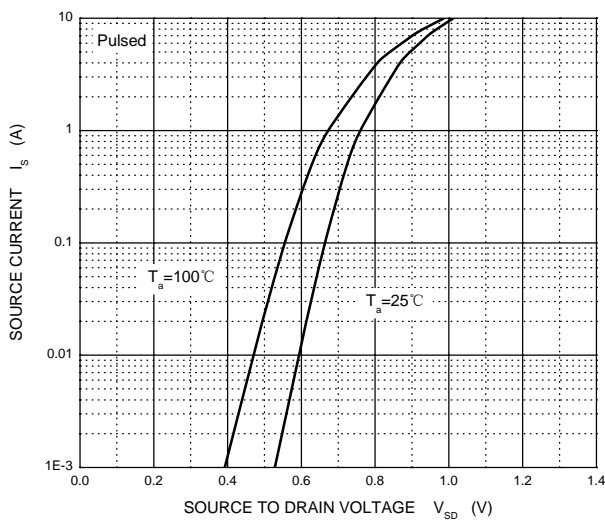

Threshold Voltage

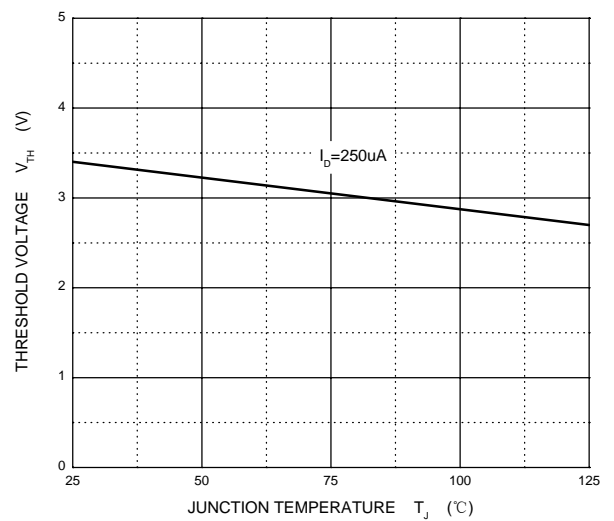

TO-220-3L Package Outline Dimensions

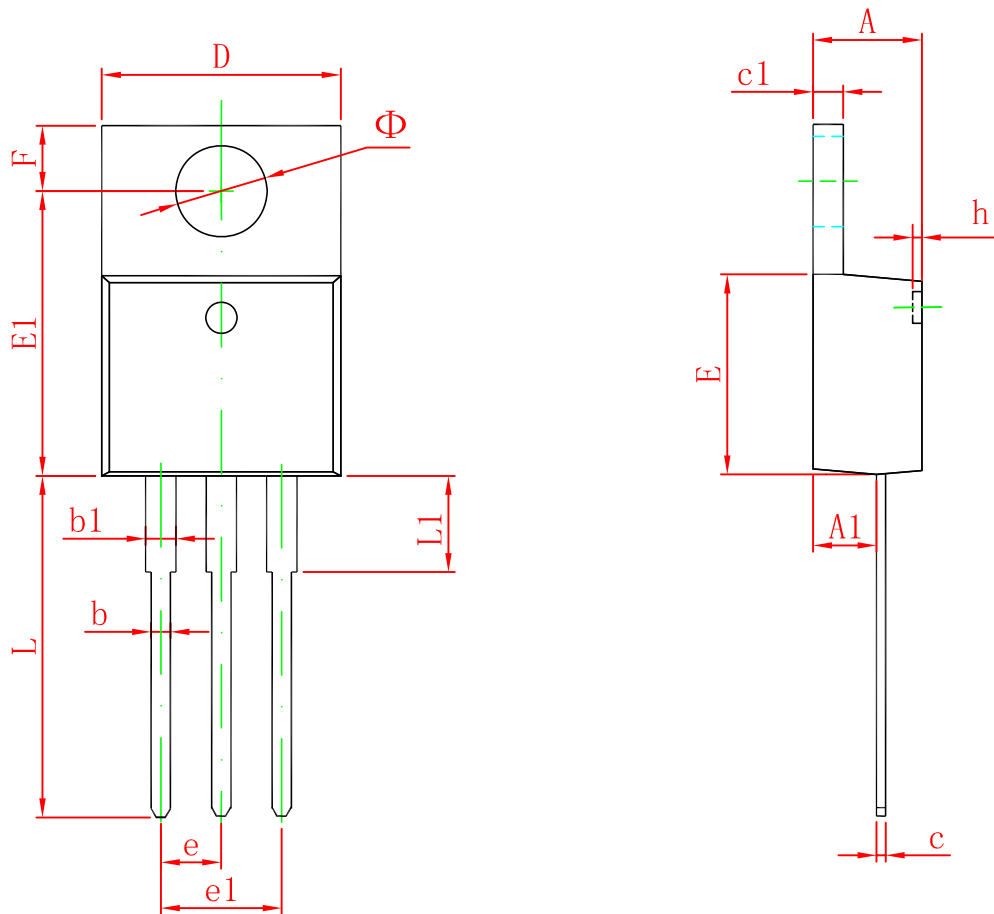

Symbol	Dimensions In Millimeters		Dimensions In Inches	
	Min	Max	Min	Max
A	4.470	4.670	0.176	0.184
A1	2.520	2.820	0.099	0.111
b	0.710	0.910	0.028	0.036
b1	1.170	1.370	0.046	0.054
c	0.310	0.530	0.012	0.021
c1	1.170	1.370	0.046	0.054
D	10.010	10.310	0.394	0.406
E	8.500	8.900	0.335	0.350
E1	12.060	12.460	0.475	0.491
e	2.540 TYP		0.100 TYP	
e1	4.980	5.180	0.196	0.204
F	2.590	2.890	0.102	0.114
h	0.000	0.300	0.000	0.012
L	13.400	13.800	0.528	0.543
L1	3.560	3.960	0.140	0.156
Φ	3.735	3.935	0.147	0.155