



TO-220 Plastic-Encapsulate MOSFETS

CJP12N60 600V N-Channel Power MOSFET

General Description

This advanced technology has been especially tailored to minimize on-state resistance, provide superior switching performance, and withstand high energy pulse in the avalanche and commutation mode. These devices are well suited for high efficiency switch mode power supply.

FEATURE

- Low C_{RSS}
- Fast switching
- Improved dv/dt capability

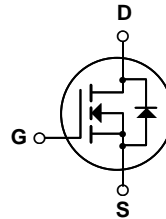
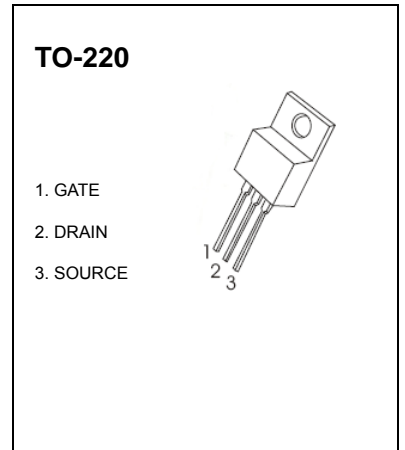

Maximum ratings ($T_a=25^\circ\text{C}$ unless otherwise noted)

Parameter	Symbol	Value	Unit
Drain-Source Voltage	V_{DS}	600	V
Gate-Source Voltage	V_{GS}	± 30	
Continuous Drain Current	I_D	12	A
Single Pulsed Avalanche Energy (note1)	E_{AS}	790	mJ
Power Dissipation	P_D	2	W
Thermal Resistance from Junction to Ambient	$R_{\theta JA}$	62.5	
Operating Temperature	T_J	150	$^\circ\text{C}$
Storage Temperature	T_{STG}	-55 ~ +150	

Electrical characteristics (T_a=25°C unless otherwise noted)

Parameter	Symbol	Test Condition	Min	Typ	Max	Units
Off characteristics						
Drain-source breakdown voltage	V _{(BR)DSS}	V _{GS} = 0V, I _D =250μA	600			V
Drain-source diode forward voltage(note2)	V _{SD}	V _{GS} = 0V, I _S =12A			1.4	
Zero gate voltage drain current	I _{DSS}	V _{DS} =600V, V _{GS} =0V			10	μA
Gate-body leakage current, forward(note2)	I _{GSSF}	V _{DS} =0V, V _{GS} =30V			100	nA
Gate-body leakage current, reverse(note2)	I _{GSSR}	V _{DS} =0V, V _{GS} =-30V			-100	
On characteristics (note2)						
Gate-threshold voltage	V _{GS(th)}	V _{DS} =V _{GS} , I _D =250μA	2.0		4.0	V
Static drain-source on-resistance	R _{DS(on)}	V _{GS} =10V, I _D =6.0A			0.8	Ω
Dynamic characteristics (note 3)						
Input capacitance	C _{ISS}	V _{DS} =25V, V _{GS} =0V, f =1MHz		1800		pF
Output capacitance	C _{OSS}			200		
Reverse transfer capacitance	C _{ISS}			25		
Switching characteristics(note3)						
Turn-on delay time	t _{d(on)}	V _{DD} =325V, R _G =4.7Ω, I _D =12A		30		ns
Turn-on rise time	t _r			90		
Turn-off delay time	t _{d(off)}			160		
Turn-off fall time	t _f			90		

Notes :

1. L=10mH, I_{AS}=12 A, V_{DD}=50V, R_G=25Ω, Starting T_J=25°C.
2. Pulse Test : Pulse width≤300μs, duty cycle ≤2%.
3. These parameters have no way to verify.