

TO-220F Plastic-Encapsulate MOSFETS

CJPF01N65B

N-Channel Power MOSFET

GENERAL DESCRIPTION

This advanced high voltage MOSFET is designed to stand high energy in the avalanche mode and switch efficiently. This new high energy device also offers a drain-to-source diode fast recovery time. Designed for high voltage, high speed switching applications such as power supplies, converters, power motor controls and bridge circuits.

FEATURE

- High Current Rating
- Lower $R_{DS(on)}$
- Lower Capacitance
- Lower Total Gate Charge
- Tighter V_{SD} Specifications
- Avalanche Energy Specified

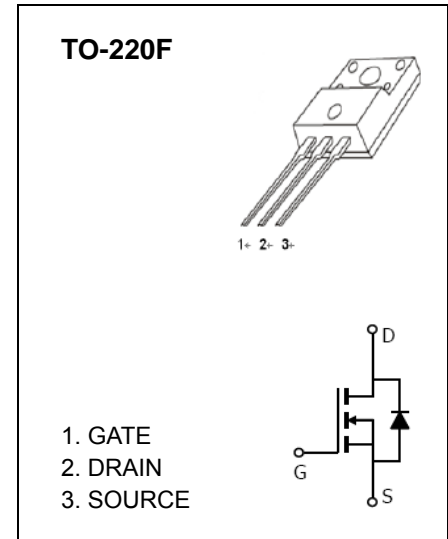

Maximum ratings ($T_a=25^\circ\text{C}$ unless otherwise noted)

Parameter	Symbol	Value	Unit
Drain-Source Voltage	V_{DS}	650	V
Gate-Source Voltage	V_{GS}	± 20	
Continuous Drain Current	I_D	1	A
Pulsed Drain Current	I_{DM}	4	
Single Pulsed Avalanche Energy (note1)	E_{AS}	5	mJ
Power Dissipation	P_D	2	W
Thermal Resistance from Junction to Ambient	$R_{\theta JA}$	62.5	$^\circ\text{C}/\text{W}$
Operating and Storage Temperature Range	T_J, T_{STG}	-55 ~ +150	$^\circ\text{C}$
Maximum lead temperature for soldering purposes , 1/8" from case for 5 seconds	T_L	260	

Electrical characteristics (T_a=25°C unless otherwise noted)

Parameter	Symbol	Test Condition	Min	Typ	Max	Unit
Off characteristics						
Drain-source breakdown voltage	V _{(BR)DSS}	V _{GS} = 0V, I _D = 250μA	650			V
Drain-source diode forward voltage(note2)	V _{SD}	V _{GS} = 0V, I _S = 1A			1.5	
Zero gate voltage drain current	I _{DSS}	V _{DS} = 600V, V _{GS} = 0V			100	μA
Gate-body leakage curren (note2)	I _{GSS}	V _{DS} = 0V, V _{GS} = ± 20V			± 100	nA
On characteristics (note2)						
Gate-threshold voltage	V _{GS(th)}	V _{DS} = V _{GS} , I _D = 250μA	2.0		4.0	V
Static drain-source on-resistance	R _{DS(on)}	V _{GS} = 10V, I _D = 0.6A			14	Ω
Dynamic characteristics (note 3)						
Input capacitance	C _{ISS}	V _{DS} = 25V, V _{GS} = 0V, f = 1MHz		210		pF
Output capacitance	C _{OSS}			28		
Reverse transfer capacitance	C _{RSS}			4.2		
Switching characteristics (note 3)						
Total gate charge	Q _g	V _{DS} = 480V, V _{GS} = 10V, I _D = 4.0A		5.0	10	nC
Gate-source charge	Q _{gs}			2.7		
Gate-drain charge	Q _{gd}			2.0		
Turn-on delay time (note3)	t _{d(on)}	V _{DD} = 300V, V _{GS} = 10V, R _G = 18Ω, I _D = 1A		8		ns
Turn-on rise time (note3)	t _r			21		
Turn-off delay time (note3)	t _{d(off)}			18		
Turn-off fall time (note3)	t _f			24		

Notes :

1. L=10mH, I_L=1 A, V_{DD}=50V, V_{GS}=10V, R_G=25Ω, Starting T_J=25°C.
2. Pulse Test : Pulse width ≤ 300μs, duty cycle ≤ 2%.
3. These parameters have no way to verify.

TO-220F Package Outline Dimensions

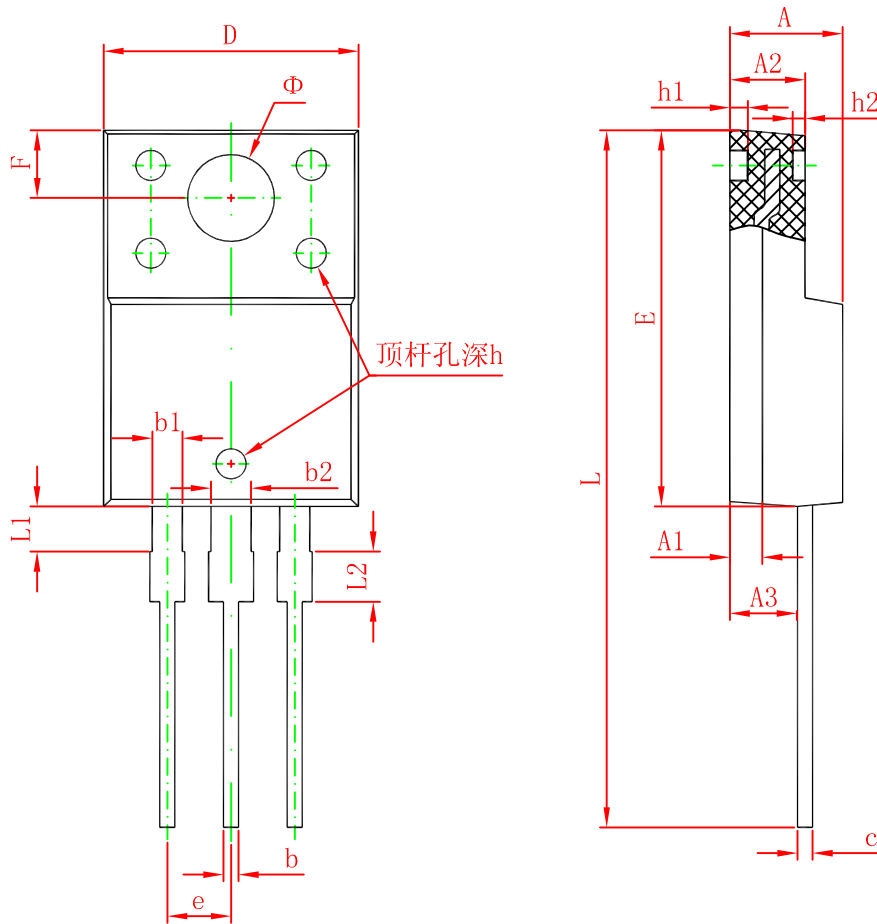

Symbol	Dimensions In Millimeters		Dimensions In Inches	
	Min.	Max.	Min.	Max.
A	4.300	4.700	0.169	0.185
A1	1.300 REF.		0.051 REF.	
A2	2.800	3.200	0.110	0.126
A3	2.500	2.900	0.098	0.114
b	0.500	0.750	0.020	0.030
b1	1.100	1.350	0.043	0.053
b2	1.500	1.750	0.059	0.069
c	0.500	0.750	0.020	0.030
D	9.960	10.360	0.392	0.408
E	14.800	15.200	0.583	0.598
e	2.540 TYP.		0.100 TYP.	
F	2.700 REF.		0.106 REF.	
Φ	3.500 REF.		0.138 REF.	
h	0.000	0.300	0.000	0.012
h1	0.800 REF.		0.031 REF.	
h2	0.500 REF.		0.020 REF.	
L	28.000	28.400	1.102	1.118
L1	1.700	1.900	0.067	0.075
L2	1.900	2.100	0.075	0.083