

型名: CKRH3D11/HP

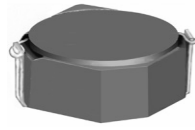

## 1. 尺寸(毫米)

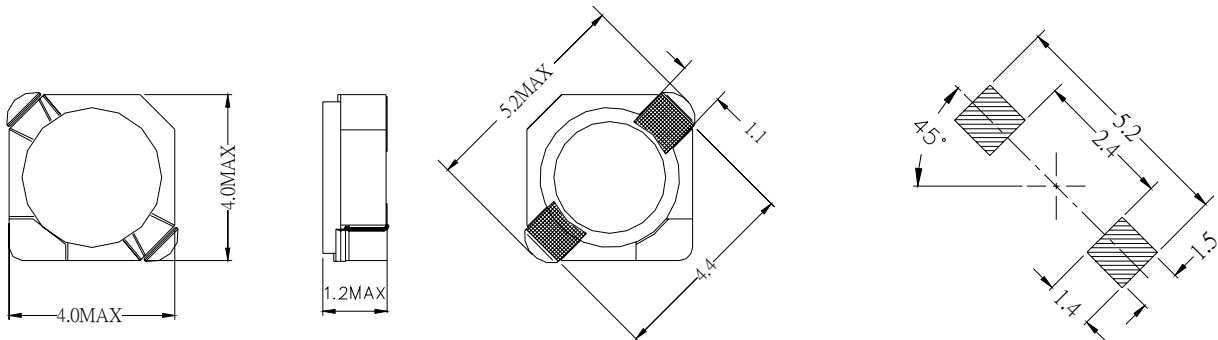

## 2. 技术参数

NO.	品名	表示	电感( $\mu$ H)	电阻 (m $\Omega$ ) (MAX)	额定电流 (A)
1	CHRH3D11HP-0R6	A	0.6	54	
2	CHRH3D11HP-1R2	B	1.2	77	
3	CHRH3D11HP-1R5	C	1.5	98	1.43
4	CHRH3D11HP-2R7	D	2.7	123	1.28
5	CHRH3D11HP-3R6	E	3.6	166	0.98
6	CHRH3D11HP-4R7	F	4.7	200	0.86
7	CHRH3D11HP-6R5	G	6.5	273	0.78
8	CHRH3D11HP-100	H	10	358	0.68
9	CHRH3D11HP-120	I	12	398	0.63
10	CHRH3D11HP-150	J	15	548	0.53
11	CHRH3D11HP-180	K	18	704	0.45
12	CHRH3D11HP-220	L	22	923	0.36

无铅

测定频率 100kHz

电感公差范围 ( $\pm 30\%$ )

额定电流: 指电感值减小到原值 65%时的电流.