

型名: CKRH3D14/LD

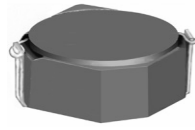

1. 尺寸 (毫米)

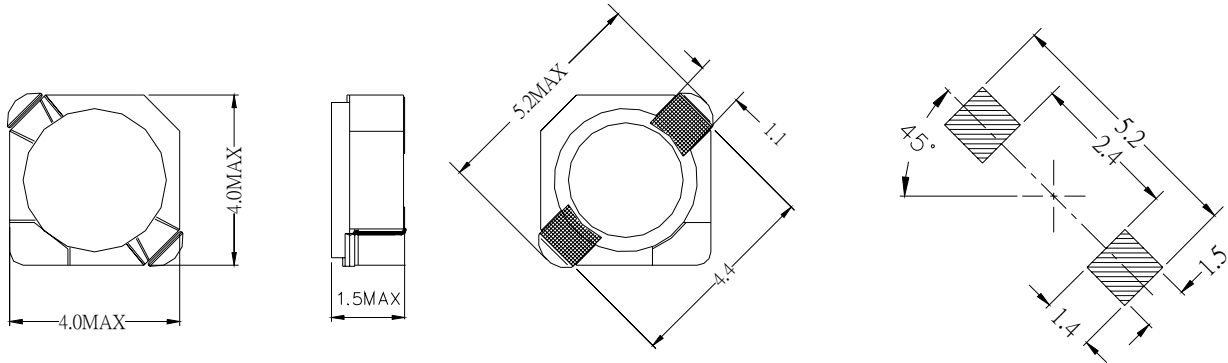

2. 技术参数

NO.	品名	表示	电感(μ H)	电阻 (m Ω) (MAX)	额定电流 (A)
1	CKRH3D14/LD-1R2	A	1.2	38	1.46
2	CKRH3D14/LD-1R5	B	1.5	46	1.33
3	CKRH3D14/LD-2R0	C	2.0	53	1.13
4	CKRH3D14/LD-2R5	D	2.5	66	1.03
5	CKRH3D14/LD-3R0	E	3.0	75	0.93
6	CKRH3D14/LD-3R9	F	3.9	96	0.76
7	CKRH3D14/LD-4R5	G	4.5	103	0.73
8	CKRH3D14/LD-5R6	H	5.6	157	0.68
9	CKRH3D14/LD-6R8	I	6.8	171	0.58
10	CKRH3D14/LD-100	K	10	218	0.48
11	CKRH3D14/LD-120	L	12	268	0.43
12	CKRH3D14/LD-150	M	15	300	0.38
13	CKRH3D14/LD-220	O	22	447	0.33
14	CKRH3D14/LD-330	Q	33	848	0.26
15	CKRH3D14/LD-470	R	47	1076	0.23

无铅

测定频率 100kHz

电感公差范围 ($\pm 30\%$)

额定电流: 指电感值减小到原值 65%时的电流。