

型名: CKRH3D16/LD

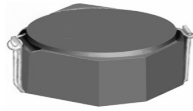

## 1. 尺寸 (毫米)

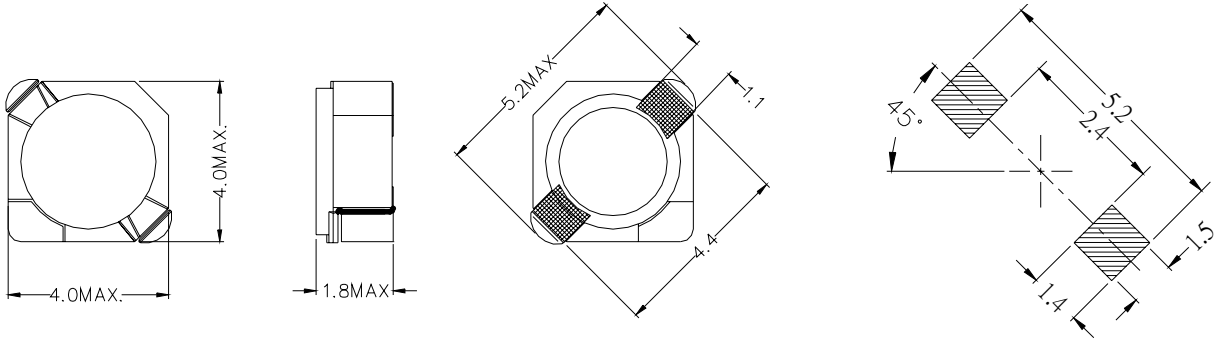

## 2. 技术参数

NO.	品名	表示	电感( $\mu$ H)	电阻 (m $\Omega$ ) (MAX)	额定电流 (A)
1	CKRH3D16/LD-3R3	E	3.3	64	0.78
2	CKRH3D16/LD-3R9	E	3.9	81	0.70
3	CKRH3D16/LD-4R7	G	4.7	89	0.66
4	CKRH3D16/LD-5R6	H	5.6	100	0.60
5	CKRH3D16/LD-6R8	I	6.8	128	0.56
6	CKRH3D16/LD-8R2	J	8.2	138	0.49
7	CKRH3D16/LD-100	K	10	188	0.42
8	CKRH3D16/LD-120	L	12	203	0.40
9	CKRH3D16/LD-150	M	15	272	0.35
10	CKRH3D16/LD-180	N	18	325	0.32
11	CKRH3D16/LD-220	O	22	356	0.28
12	CKRH3D16/LD-270	P	27	468	0.26
13	CKRH3D16/LD-330	Q	33	558	0.24
14	CKRH3D16/LD-390	R	39	698	0.22
15	CKRH3D16/LD-470	S	47	775	0.18

无铅

测定频率 100kHz

电感公差范围 ( $\pm 30\%$ )

额定电流: 指电感值减小到原值 65%时的电流.