



Chunghwa Picture Tubes, Ltd.

Product Specification

To : RB

Date : 090516

TFT LCD

CLAA061LA0ACW

ACCEPTED BY : (V0.4)

Tentative

APPROVED BY	CHECKED BY	PREPARED BY
張聖暉	李家銘	羅宇城

Prepared by :

Product Planning Management Division
Small & Medium TFT Product Business Unit
CHUNGHWA PICTURE TUBES, LTD.

1127 Hopin Rd., Padeh, Taoyuan, Taiwan 334, R.O.C.
TEL: +886-3-3675151 FAX: +886-3-377-3858

Doc.No: SPEC_CLAA061LA0ACW_V0.4_RB_090516

Issue Date: 2009/06/12

REVISION STATUS

Revision Notice	Description	Page	Rev. Date
0.0	First revision (Tentative)	--	2009/02/23
0.1	Revise TFT LCD Power Voltage	6	2009/04/16
0.1	Revise Power 、 Signal sequence	7	2009/04/16
0.1	Revise Backlight Unit	8	2009/04/16
0.1	Revise the Interface Connection	9,10	2009/04/16
0.1	Revise the Input Signal	11	2009/04/16
0.1	Revise the Mechanical Dimension	13,14	2009/04/16
0.1	Revise the Reliability Test	17	2009/04/16
0.2	Revise Backlight Unit	8	2009/04/17
0.2	Revise CN2 (BLU connector)	10	2009/04/17
0.3	Revise ABSOLUTE MAXIMUM RATINGS	5	2009/04/27
0.3	Revise Power 、 Signal sequence	7	2009/04/27
0.3	Revise Backlight Unit	8	2009/04/27
0.3	Revise Optical characteristics	15	2009/04/27
0.4	Revise General specifications table	4	2009/06/12
0.4	Revise TFT LCD Power Voltage	6	2009/06/12
0.4	Revise TFT-LCD Current Consumption	7	2009/06/12
0.4	Revise Backlight Unit	8	2009/06/12
0.4	Revise Horizontal Timing Specification	11	2009/06/12
0.4	Revise Optical Characteristics	15	2009/06/12

CONTENTS

1. OVERVIEW	4
2. ABSOLUTE MAXIMUM RATINGS	5
3. ELECTRICAL CHARACTERISTICS	6
3.1 TFT LCD Power Voltage	6
3.2 TFT-LCD Current Consumption	7
3.3 Power 、 Signal sequence	7
3.4 Backlight Unit	8
4. INTERFACE CONNECTION	9
4.1 CN1	9
4.2 CN2 (BLU connector)	10
5. INPUT SIGNAL	11
5.1 Timing Specification	11
5.2 Timing Sequence (Timing chart)	11
6. MECHANICAL DIMENSION	13
6.1 Front Side	13
6.2 Rear Side	14
7. OPTICAL CHARACTERISTICS	15
8. RELIABILITY TEST CONDITIONS	17
8.1. Temperature and humidity	17
8.2. Shock and Vibration	17
8.3. ESD	17
8.4. Judgment Standard	17

1. OVERVIEW

CLAA061LA0ACW is 15.4cm(6.1") color TFT-LCD (Thin Film Transistor Liquid Crystal Display) module composed of LCD panel, driver ICs, control circuit and LED backlight. By applying 800×480 images are displayed on the 6.1" diagonal screen. Display 262K colors by 6 Bit R.G.B signal input.

General specifications are summarized in the following table:

ITEM	SPECIFICATION
Display Area (mm)	136.2(H)×72(V) (6.1-inch diagonal)
Number of Pixels	800(H) x 3(RGB) x 480(V)
Pixel Pitch (mm)	0.17025(H) ×0.150(V)
Color Pixel Arrangement	RGB vertical stripe
Display Mode	Normally white, TN
Number of Colors	262,144
Optimum Viewing Angle	6 o'clock
Brightness (cd/m ²)	500nit(Typ)
Response Time (Tr+Tf)	20ms (Typ)
Viewing Angle(BL on,CR≥10)	140 Degree(Horizontal) ; 120 Degree(Vertical)
Power Consumption (W)	2.2W(Typ)
Electrical Interface(data)	TTL
Module Size (mm)	149.0(W)×82.9(H)×6.2(D)
Module Weight (g)	130 (Typ)
Backlight Unit	LED
Surface Treatment	Anti-Glare type , Hardness:3H

2. ABSOLUTE MAXIMUM RATINGS

The following are maximum values which, if exceeded, may cause faulty operation or damage to the unit.

Item	Symbol	Min.	Max.	Unit	Note
Digital Supply Voltage	V _{cc}	-0.5	5.0	V	
Analog Supply Voltage	AVDD	-0.5	13.5	V	
Gate On Voltage	V _{GH}	-0.3	40	V	
Gate Off Voltage	V _{GL}	-20	0.3	V	
Gate On-Gate Off Voltage	V _{GH-VGL}	-0.3	40	V	
Forward Current(per LED)	I _f	-	25	mA	
Reverse Voltage(per LED)	V _R		5	V	
Pulse Forward Current(per LED)	I _{fp}		80	mA	【Note 2】
Operation Temperature	T _{op}	-30	85	°C	【Note 1】
Storage Temperature	T _{stg}	-40	90	°C	【Note 1】

【Note】

【Note1】 If users use the product out off the environment operation range (temperature and humidity) ,it will concern for visual quality.

【Note2】 I_{fp} Conditions : Pulse Width ≤ 10msec , Duty ≤ 1/10.

3. ELECTRICAL CHARACTERISTICS

3.1 TFT LCD Power Voltage

Ta=25°C

Item	Symbol	Min.	Typ.	Max.	Unit.	Note
Digital Supply Voltage	VCC	3	3.3	3.6	V	
Analog Supply Voltage	AVDD	9.4	9.6	9.8	V	
Gate On Voltage	VGH	17	18	19	V	
Gate Off Voltage	VGL	-6.6	-6	-5.4	V	
Common Voltage	VCDC	3.28	3.38	3.48	V	【Note1】
Gamma Voltage	V1	-	8.37	-	V	
	V2	-	6.89	-	V	
	V3	-	6.49	-	V	
	V4	-	6.15	-	V	
	V5	-	5.23	-	V	
	V6	-	3.71	-	V	
	V7	-	2.79	-	V	
	V8	-	2.45	-	V	
	V9	-	2.05	-	V	
	V10	-	0.57	-	V	
Logic Input Voltage	VIH	0.7VCC	-	VCC	V	
	VIL	GND	-	0.3VCC	V	

【Note】

【Note1】 Please adjust VCDC to make the flicker level be minimum.

3.2 TFT-LCD Current Consumption

Item	Symbol	Condition	Min.	Typ.	Max.	Unit.	Note
Gate on Current	IVGH	VGH = 18 V	-	0.5	1	mA	【Note1】
Gate off Current	IVGL	VGL = -6 V	-	0.5	1	mA	【Note1】
Digital Current	IVCC	VCC = 3.3V	-	5	10	mA	【Note1】
Analog Current	IAVDD	AVDD = 9.6 V	-	35	45	mA	【Note1】
Total Power Consumption	PC		-	364.5	489	mW	【Note1】

【Note】

【Note1】 Typical: Under 64 gray pattern @ Vcc = 3.3 V (Frame rate is 60 Hz)

Maximum: Under black pattern @ Vcc = 3.0 V (Frame rate is 60 Hz)



(a) Gray-level Pattern

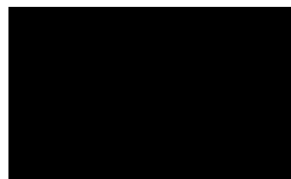

(b) Black Pattern

3.3 Power 、 Signal sequence

Power On : VCC→AVDD/VGL→VGH→Video & Logic Signal

Power Off : Video & Logic Signal→VGH→AVDD/VGL→VCC

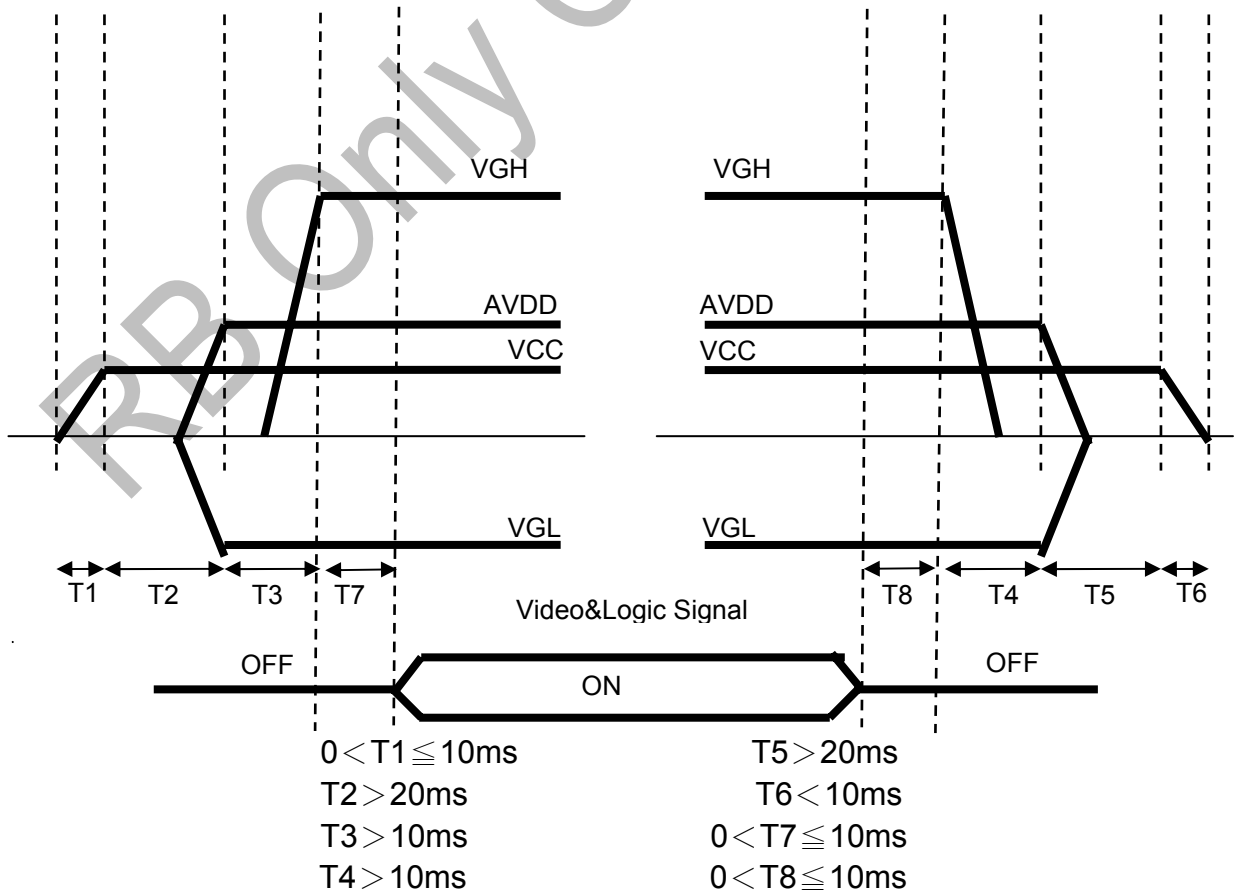

3.4 Backlight Unit

Ta=25°C

ITEM	SYMBOL	MIN.	TYP.	MAX.	UNIT	Note
LED current	IL	--	100	--	mA	
LED voltage	VL	16.62	19.2	21.18	V	
Power consumption	WL	--	1.92	--	W	
LED Life Time	N/A	TBD	TBD	TBD	Hour	IF=20mA

Note:

*1)LED Circuit Diagram

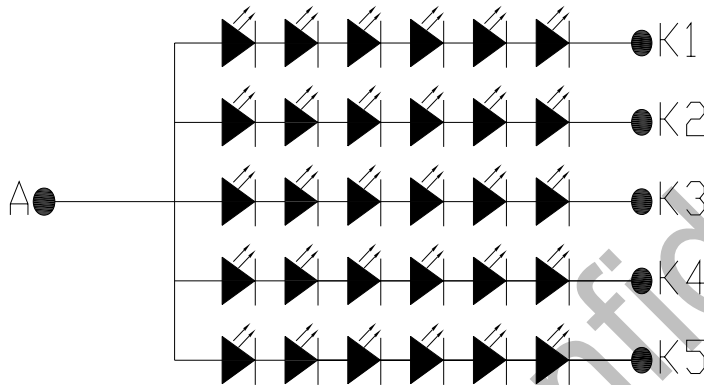

*2)A : Anode(+) , K : Cathode(-)

*3)We suggest using the constant current control to avoid the leakage light and brightness quality issue.

*4) Dification of Led lifetime : Luminance < Initial luminance 50%

4. INTERFACE CONNECTION

4.1 CN1

Pin NO.	SYMBOL	DESCRIPTION
1	GND	Power Ground
2	DIO1	Horizontal start Pulse Signal I/O
3	NC	NC
4	VR 1	Gamma Voltage Level 1
5	VR 2	Gamma Voltage Level 2
6	VR 3	Gamma Voltage Level 3
7	VR 4	Gamma Voltage Level 4
8	VR 5	Gamma Voltage Level 5
9	VR 6	Gamma Voltage Level 6
10	VR 7	Gamma Voltage Level 7
11	VR 8	Gamma Voltage Level 8
12	VR 9	Gamma Voltage Level 9
13	VR 10	Gamma Voltage Level 10
14	D00	Red Data (LSB)
15	D01	Red Data
16	D02	Red Data
17	D03	Red Data
18	D04	Red Data
19	D05	Red Data (MSB)
20	D10	Green Data (LSB)
21	D11	Green Data
22	D12	Green Data
23	D13	Green Data
24	D14	Green Data
25	D15	Green Data (MSB)
26	D20	Blue Data (LSB)
27	D21	Blue Data
28	D22	Blue Data
29	D23	Blue Data
30	D24	Blue Data
31	D25	Blue Data (MSB)
32	LD	Latch The Polarity of Output and Switch The New Data to Output
33	SHL	Select Left / Right Shift
34	AVDD	Power Supply for Analog Circuit
35	AVDD	Power Supply for Analog Circuit
36	GND	Power Ground
37	GND	Power Ground
38	CLK	Horizontal Clock
39	DVDD	Digital Power +3.3V
40	DIO2	Horizontal start Pulse Signal I/O
41	GND	Power Ground
42	GND	Power Ground
43	GND	Power Ground
44	STV2	Vertical start Pulse Signal I/O
45	UD	Up / Down Control Pin
46	OEV	Output Enable
47	VCLK	Vertical Clock
48	GND	Power Ground
49	GND	Power Ground
50	POL	Polarity Selection
51	XON	Gate Output all-on control
52	NC	NC
53	VEEG	Gate OFF Voltage -6V
54	NC	NC

55	VDDG	Gate ON Voltage +18V
56	NC	NC
57	STV1	Vertical start Pulse Signal I/O
58	NC	NC
59	VCOM	Common Voltage
60	VCOM	Common Voltage

NOTE:

- 1) GND Pin must ground contact , can not be floating.
- 2)SHL : Select left or right

SHL	DIO1	DIO2	SHIFT
1	Input	Output	Right
0	Output	Input	Left

- 3)UD : Shift up or down control

UD	STV1	STV2	SHIFT
1	Input	Output	UP
0	Output	Input	Down

- 4)XON : Gate output all-on control
As XON is low then all output pins are forced to VDDG level.

4.2 CN2 (BLU connector)

Outlet connector: STARCONN FR06-S10R1HF-2-E3000

Pin No.	SYMBOL	FUNCTION
1	A	Anode
2	A	Anode
3	A	Anode
4	NC	NC
5	K1	Cathode
6	K2	Cathode
7	K3	Cathode
8	K4	Cathode
9	K5	Cathode
10	NC	NC

5. INPUT SIGNAL

5.1 Timing Specification

5.1.1 Horizontal Timing Specification

ITEM	SYMBOL	SPECIFICATION			UNIT
		Min	Typ	Max	
CLK Frequency	1/Tcph	25	32	40	MHz
CLK Pulse Width	Tcw	40%	-	60%	Tcph
Data Set-up Time	Tsu	4	-	-	ns
Data Hold Time	Thd	2	-	-	ns
Propagation Delay of DIO2/1	Tphl	6	10	15	ns
Time That The Last Data to LD	Tld	1	-	-	Tcph
Pulse Width of LD	Twd	2	-	-	Tcph
Time That LD to DIO1/2	Tlds	5	-	-	Tcph
POL Set-up Time	Tpsu	6	-	-	ns
POL Hold Time	Tphd	6	-	-	ns

5.1.2 Vertical Timing Specification

ITEM	SYMBOL	SPECIFICATION			UNIT
		Min	Typ	Max	
VCLK Frequency	1/Tcpv	-	-	200	Khz
VCLK Pulse Width	Tcpvh	2.5	-	-	μs
STVD/STVU Set-up Time	Tsu	700	-	-	ns
STVD/STVU Hold Time	Thd	700	-	-	ns
Output Enabled pulse width	Twoe	1	-	-	us

5.2 Timing Sequence (Timing chart)

5.2.1 Horizontal Timing Sequence

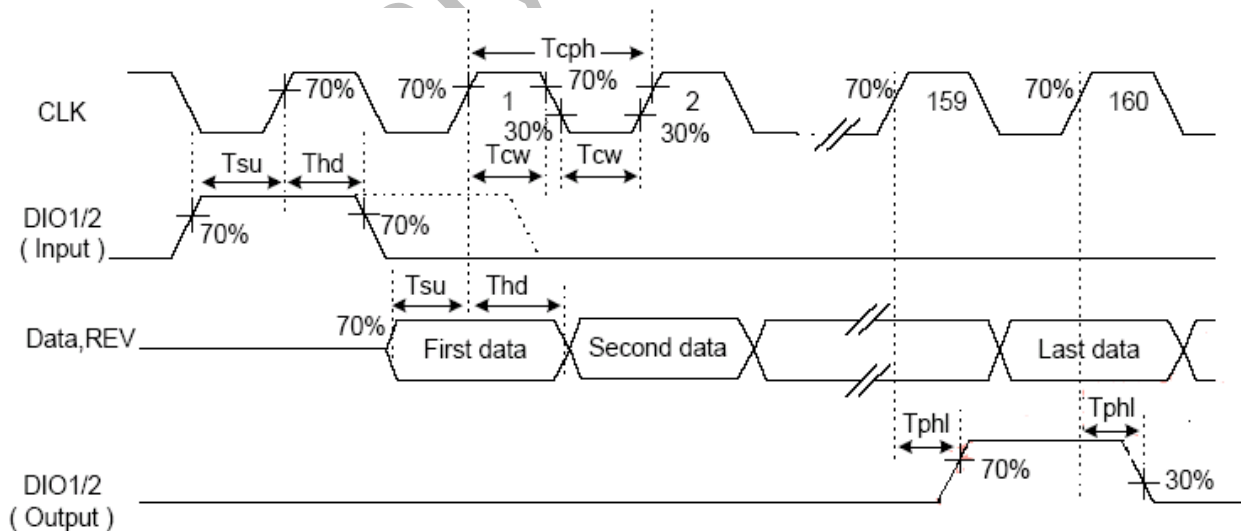

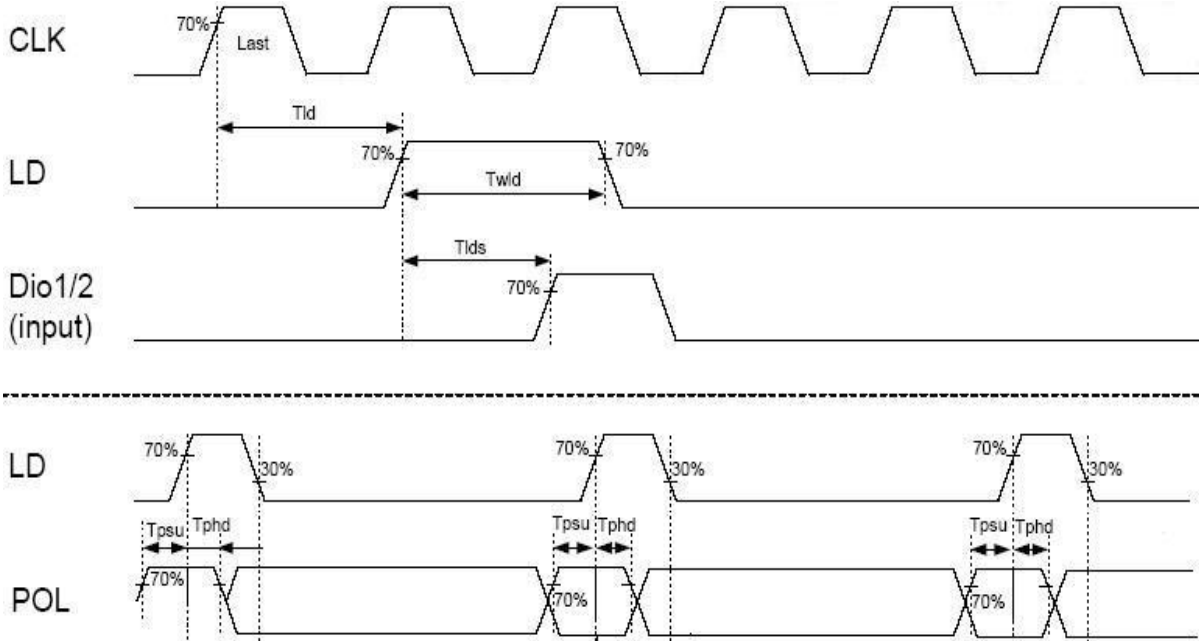

5.2.2 Vertical Timing Sequence

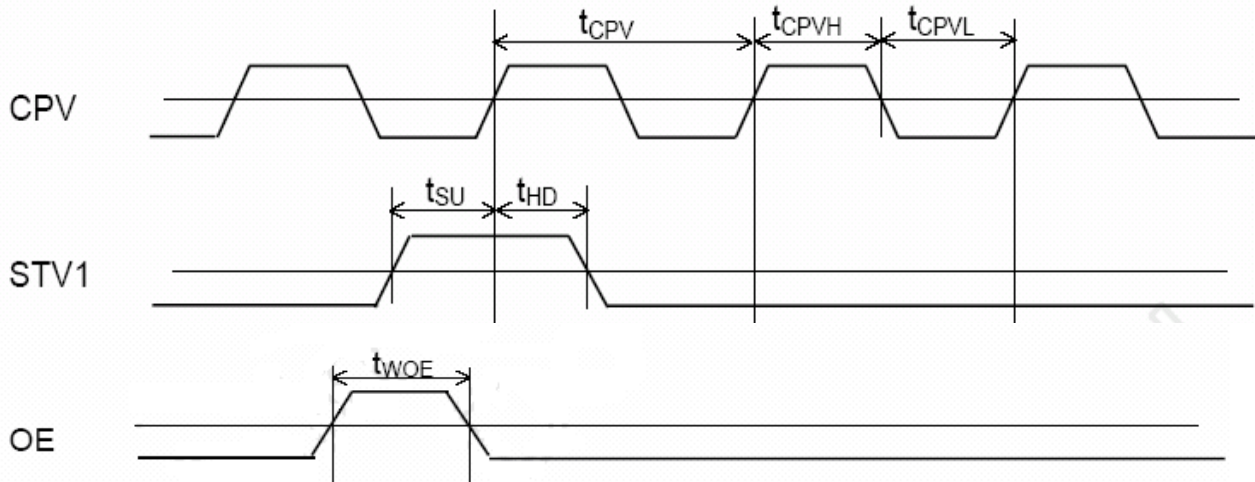

RE

6. MECHANICAL DIMENSION

6.1 Front Side

[Unit : mm]

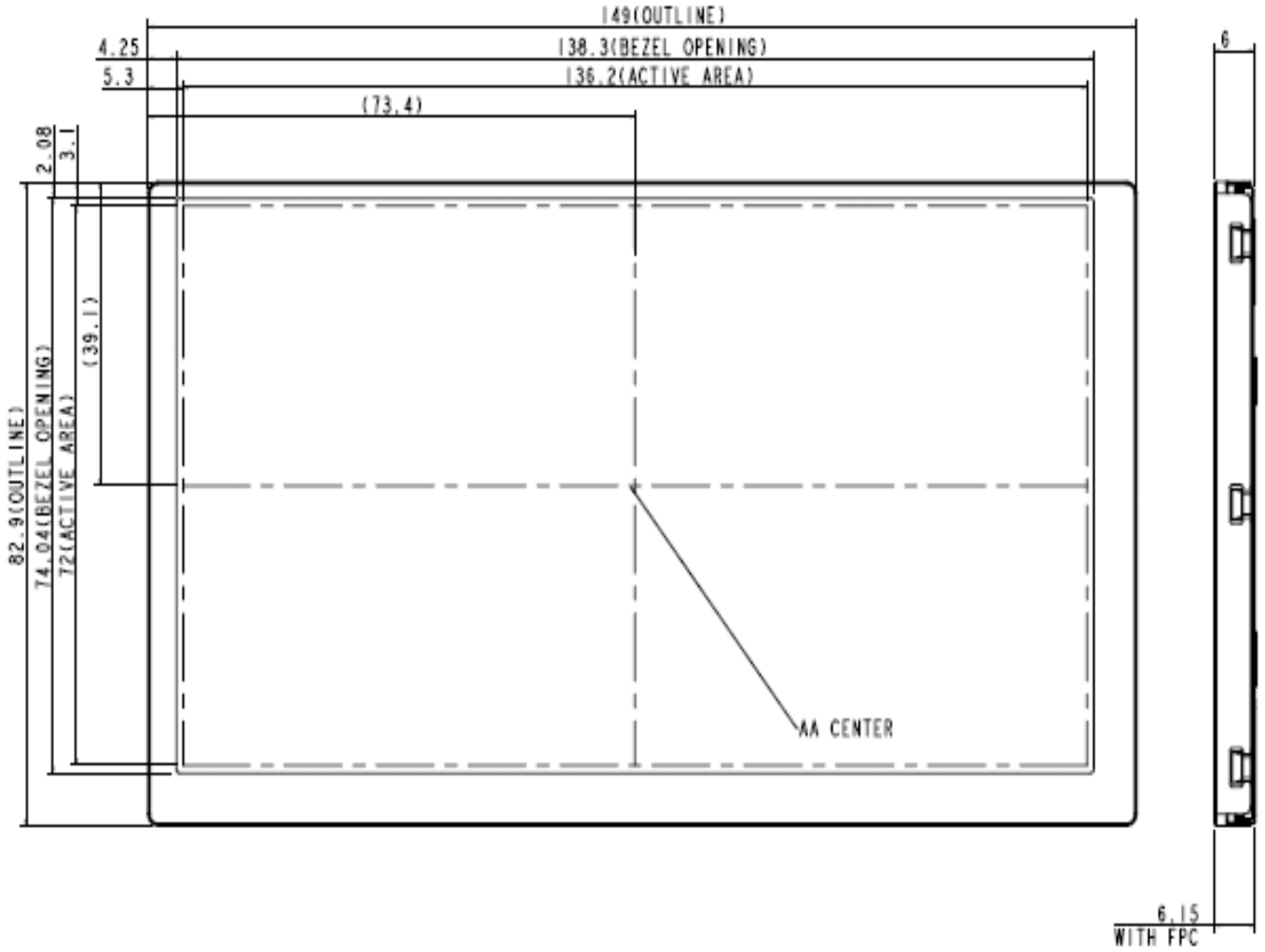

6.2 Rear Side

[Unit : mm]

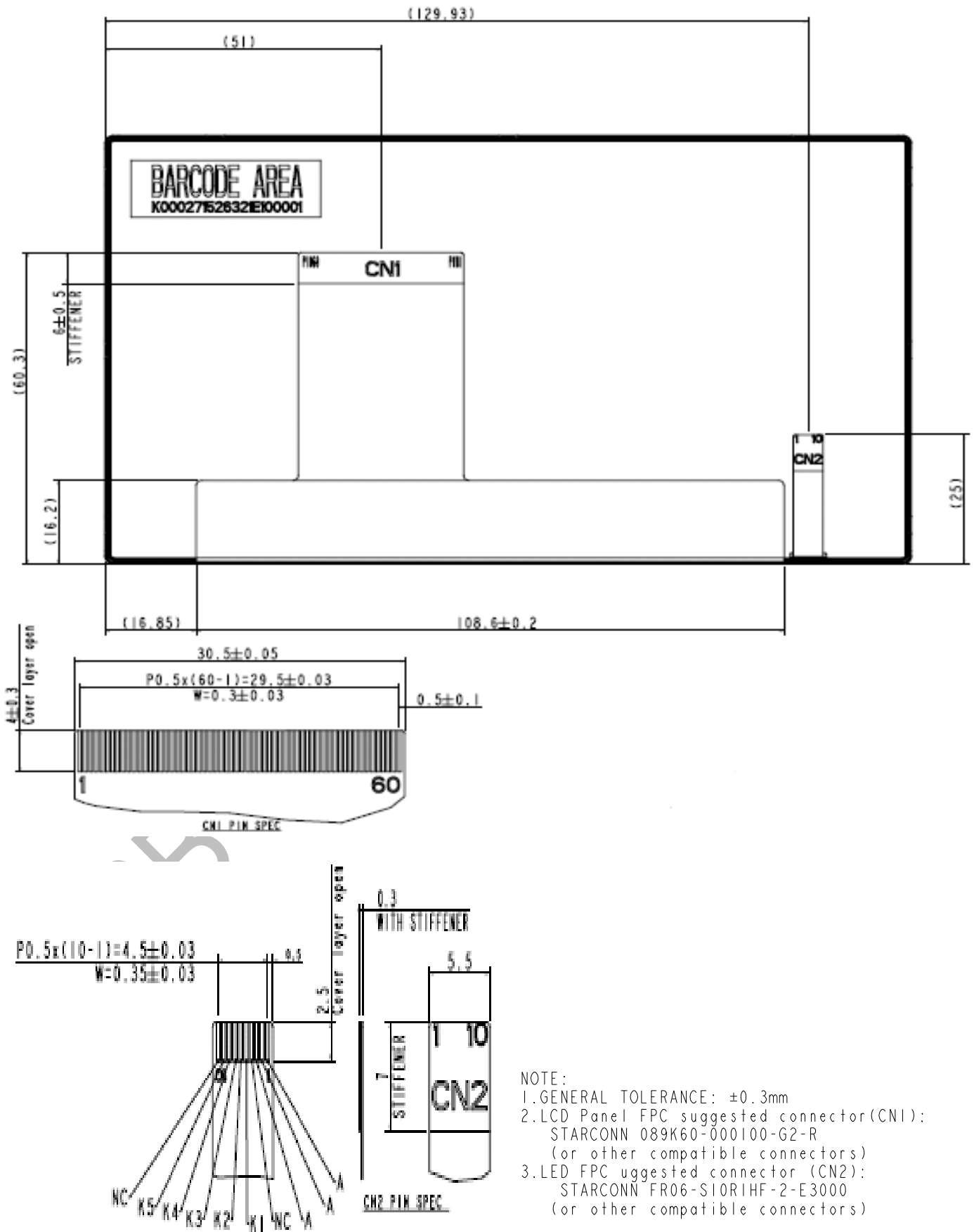

- NOTE:
1. GENERAL TOLERANCE: ±0.3mm
 2. LCD Panel FPC suggested connector (CN1):
STARCONN 089K60-000100-G2-R
(or other compatible connectors)
 3. LED FPC suggested connector (CN2):
STARCONN FR06-S10R1HF-2-E3000
(or other compatible connectors)

7. OPTICAL CHARACTERISTICS

 $T_a = 25^{\circ}\text{C}, V_{CC} = 3.3\text{V}$

ITEM	SYMBOL	CONDITION	MIN.	TYP.	MAX.	UNIT	Note	
Constrast Ratio	CR	Point-5	320	400	--	--	*1)*2)	
Luminance*)	Lw	Point-5	400	500	--	cd/m ²	*1)*3)	
Luminance Uniformity	ΔL		--	80	--	%	*1)*4)	
Response Time (White - Black)	Tr		--	7	12	ms	*3)*4)	
	Tf		--	13	18	ms		
Viewing Angle	Horizontal	ψ	CR \geq 10 Point-5	120	140	--	$^{\circ}$	*1)*2)*5)
	Vertical	θ		100	120	--	$^{\circ}$	*1)*2)*5)
Color Coordinate	White	Wx	$\theta = \phi = 0^{\circ}$ Point-5	0.273	0.313	0.353	--	*1)
		Wy		0.289	0.329	0.369		
	Red	Rx		0.584	0.624	0.664		
		Ry		0.314	0.354	0.394		
Green	Gx	0.262	0.302	0.342				
	Gy	0.600	0.640	0.680				
Blue	Bx	0.115	0.155	0.195				
	By	0.000	0.039	0.079				

Note :

*1)Measure condition : $25^{\circ}\text{C} \pm 2^{\circ}\text{C}$, $60 \pm 10\% \text{RH}$, under 10 Lux in the dark room. BM-5A (TOPCON) , viewing angle 2° . $V_{CC} = 3.3\text{V}$, LED current = 100mA , after 10 minutes operation.

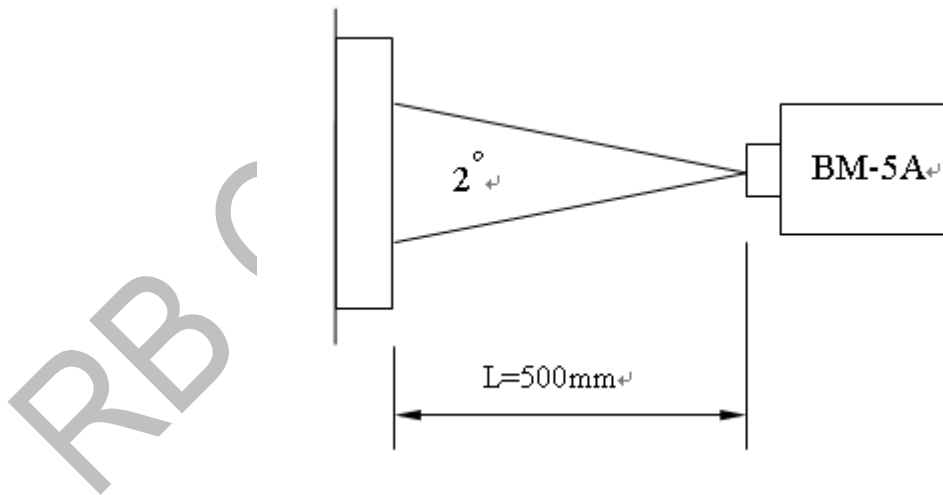

*2)Definition of contrast ratio :

Measure the point-5 as figure 8-1

Contrast Ratio (CR) = (White) Luminance of ON \div (Black) Luminance of OFF

*3)Definition of luminance :

Measure white luminance on the points-5 as figure8-1

*4)Definition of Luminance Uniformity :

Measure white luminance on the point 1~9 as figure8-1

$$\Delta L = [L(\text{MIN})/L(\text{MAX})] \times 100$$

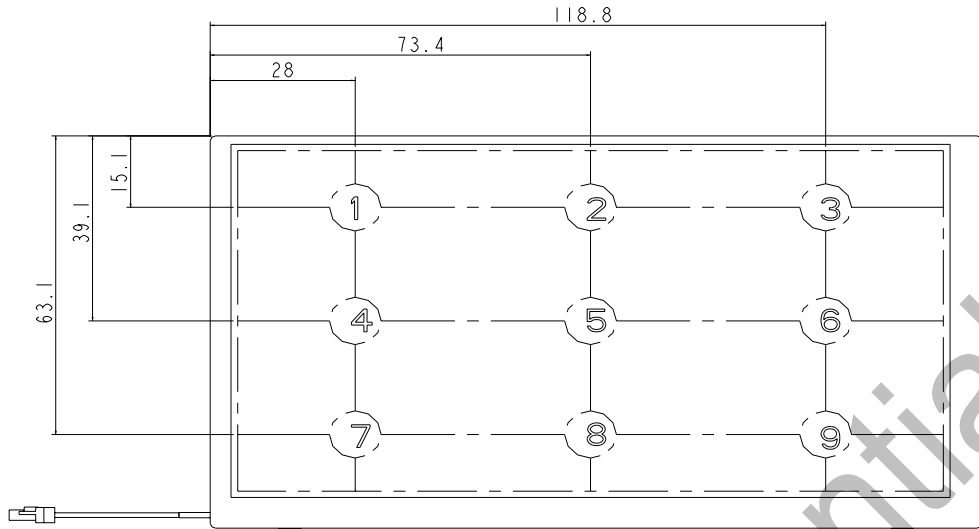

Fig8-1 Measuring point

*5) Definition of Viewing Angle(θ, ψ), refer to Fig8-2 as below :

These items are measured by EZ-CONTRAST (ELDIM) in the dark room. (no ambient light).

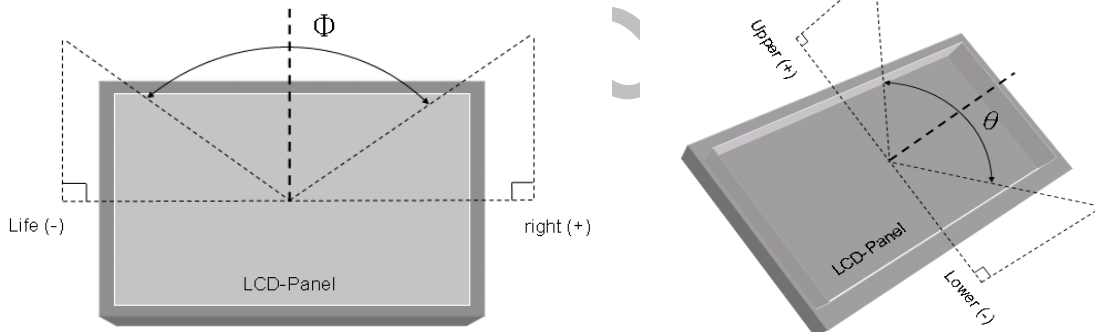

Fig8-2 Definition of Viewing Angle

*6) Definition of Response Time.(White-Black)

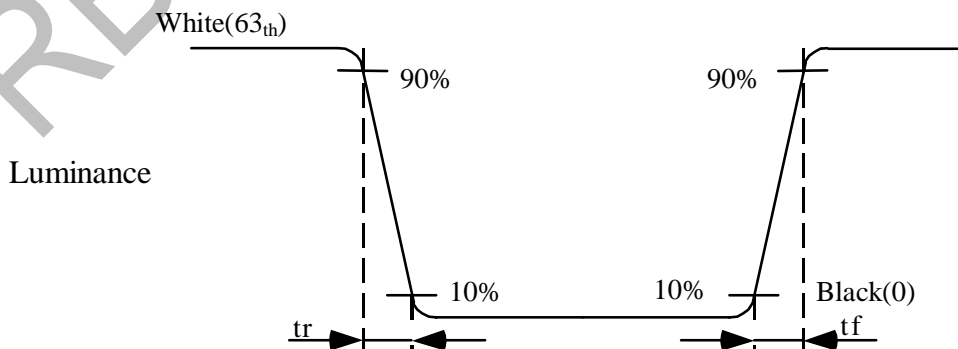

Fig8-3 Definition of Response Time(White-Black)

8. RELIABILITY TEST CONDITIONS

8.1. Temperature and humidity

TEST ITEMS	CONDITIONS	NOTE
High Temperature Operation	85°C , 1000Hrs	
High Temperature Storage	90°C , 1000Hrs	
High Temperature High Humidity Operation	60°C , 90%RH , 1000Hrs	No condensation
Low Temperature Operation	-30°C , 1000Hrs	
Low Temperature Storage	-40°C , 1000Hrs	
Thermal Shock(Non-operation)	-30°C (1Hr) ~ 85°C(1Hr) 500 cycles	

8.2. Shock and Vibration

TEST ITEMS	CONDITIONS
Shock (Non-operation)	735m/s ² (equal to 75G) 11msec 1/2 Sine wave, ±X , ±Y , ±Z , each axis 3times.
Vibration (Non-operation)	15~60Hz 29.4m/s ² (equal to 3G) 2mm XYZ 2hrs each axis

8.3. ESD

ITEM	CONDITION	NOTE
ESD	150pF , 330Ω , ±8KV contact test & ±15KV air test	*1)
	200pF , 0Ω , ± 200V contact test	*2)

NOTE:

*1) LCD glass and metal bezel ◦

*2) IF connector pins ◦

8.4. Judgment Standard

The Judgment of the above test should be made as follow:

Pass:Normal display image with no obvious non-uniformity and no line defect.Partial transformation of the module parts should be ignored.

Fail:No display image,obvious non-uniformity,or line defect.