



Chunghwa Picture Tubes, Ltd.

Product Specification

To : Syh Dar 筭達

Date : 090420

TFT LCD
CLAA070NC0DCT

ACCEPTED BY : (V0.1)

Tentative

APPROVED BY	CHECKED BY	PREPARED BY

Prepared by :

Product Planning Management Division
Small & Medium TFT Product Business Unit
CHUNGHWA PICTURE TUBES, LTD.

1127 Hopin Rd., Padeh, Taoyuan, Taiwan 334, R.O.C.
TEL: +886-3-3675151 FAX: +886-3-377-3858

Doc.No:	SPEC_CLAA070NC0DCT_V0.1_syhdar_090420	Issue Date:	2009/03/23
---------	---------------------------------------	-------------	------------

REVISION STATUS

Revision Notice	Description	Page	Rev. Date
0.0	Temtative revision	--	2009.03.10
0.1	Add EDID CODE	19	2009/3/23

CONTENTS

1. OVERVIEW	4
2. ABSOLUTE MAXIMUM RATINGS	5
3. ELECTRICAL CHARACTERISTICS	6
3.1 TFT LCD	6
3.2 TFT-LCD Current Consumption	7
3.3 Power 、 signal sequence.....	7
4. INTERFACE CONNECTION	8
5. INPUT SIGNAL(DE ONLY MODE)	10
5.1 Timing Specification	10
5.2 Timing sequence (Timing chart).....	10
5.3 LVDS Input Data mapping	11
5.4 Color Data Assignment.....	12
6. CHARACTERISTIC OF TOUCH PANEL	13
6.1 Basis characteristic	13
6.2 Design guideline for Touch-Panel.....	13
6.3 Circuit Diagram	13
7. BLOCK DIAGRAM	14
8. MECHANICAL DIMENSION	15
8.1 Front Side	15
8.2 Rear Side.....	15
9. OPTICAL CHARACTERISTICS	16
10. RELIABILITY TEST	18
10.1. Temperature and humidity	18
10.2. Shock and Vibration.....	18
10.3 ESD	18
10.4 Judgment standard	18
11. APPEXNDIX EDID CODE TABLE	19

1. OVERVIEW

CLAA070NC0DCT is 7" color TFT-LCD(Thin Film Transistor Liquid Crystal Display) module which integrates touch-screen. Composed of LCD panel,driver ICs,control circuit,and LED backlight.

The 7.0"screen produces a high resolution image that is composed of 1024×600 pixel elements in a stripe arrangement.Display 262K colors by 6 Bit R.G.B signal input.

General specifications are summarized in the following table :

ITEM	SPECIFICATION
Display Area (mm)	153.6(H)×90(V)
Number of Pixels	1024(H)×3(RGB)×600(V)
Pixel Pitch (mm)	0.15(H)×0.15(V)
Color Pixel Arrangement	RGB vertical stripe
Display Mode	Normally white
Number of colors	262,144
Viewing Direction	6 o'clock
Response Time (Tr+Tf)	20ms(typ.)
Brightness(cd/m ²)	300nit(typ.)
Viewing Angle(BL on,CR≥10)	140 degree(H) · 110degree(V)
Electrical Interface(data)	LVDS
Power consumption	2.83W (typ.)
Outline Dimension(in mm)	165(W)×102(H)×6(D)
Weight(g)	TBD(TYP)
BL unit	LED
Surface Treatment	Anti-Glare · Hardness:3H
Touch Panel Type	4 wire resistive

2. ABSOLUTE MAXIMUM RATINGS

ITEM	SYMBOL	MIN.	MAX.	UNIT	NOTE
LCD input Voltage	V _{cc}	-0.3	4.0	V	
LED input Voltage	V _{LED}	-0.3	6	V	
Signal Input Voltage	RxIN0+ ~ RxIN2+ RxIN0- ~ RxIN2- Rx CLK IN +/-	-0.3	V _{cc} +0.3	V	
Static Electricity	VESD _c	-200	+200	V	【Note2】
	VESD _m	-15K	+15K	V	
ICC Rush Current	IRUSH	--	1	A	【Note3】
Operation Temperature	T _{op}	-20	70	°C	【Note1】
Storage Temperature	T _{stg}	-30	80	°C	【Note1】

NOTE :

【Note1】 If users use the product out off the environmment operation range (temperature and humidity) ,it will concern for visual quality.

【Note2】 Test Condition: IEC 61000-4-2 ,
VESD_c : Contact discharge to input connector
VESD_m : Contact discharge to module

【Note3】 Control signal:High(+3.3V)→Low(GND)
Supply Voltage of rising time should be from R3 and C2 tune to 550 us.

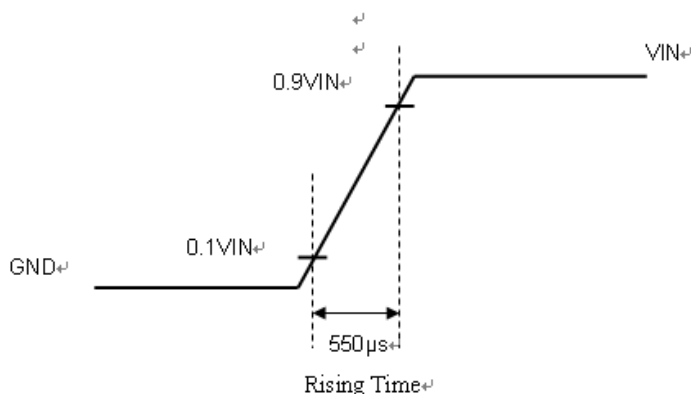
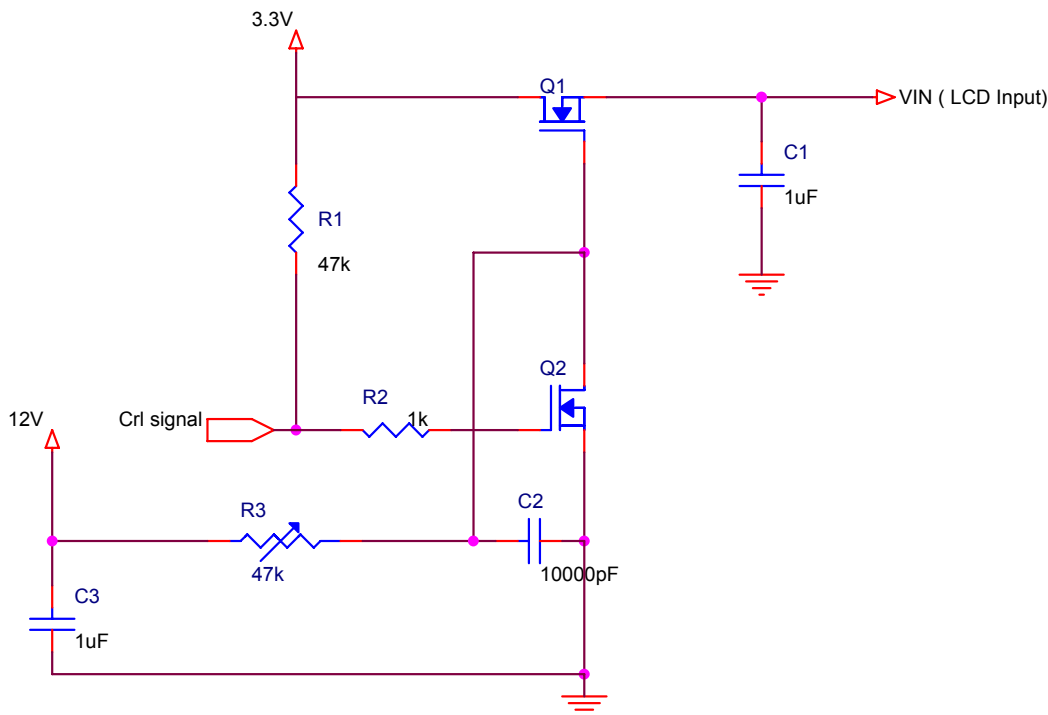

3. ELECTRICAL CHARACTERISTICS

3.1 TFT LCD

 $T_a=25^{\circ}\text{C}$

ITEM	SYMBOL	MIN.	TYP.	MAX.	UNIT	NOTE
Power Supply Voltage For LCD	VCC	3.0	3.3	3.6	V	
Power Supply Voltage For LED	VLED	4.5	5.0	5.5		
Logic Input Voltage (LVDS:IN+,IN-)	VCM	1.08	1.2	1.32	V	[Note1]
	VID	250	350	450	mV	[Note1]
	VTH	--	--	100	mV	[Note1]
	VTL	-100	--	--	mV	[Note1] When VCM=+1.2V
ADJ Input Voltage	VIH	3.0		3.3	V	
	VIL	GND		0.3	V	

NOTE :

[Note1] LVDS signal

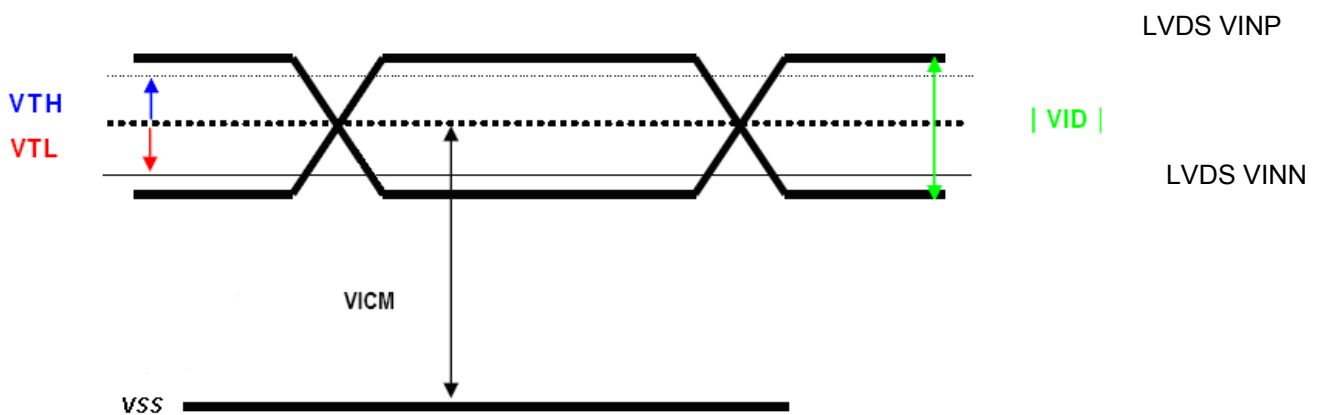

3.2 TFT-LCD Current Consumption

ITEM	SYMBOL	MIN	TYP	MAX	UNIT	NOTE
LCD Power Current	ICC	--	250	300	mA	【Note1】
LED Power Current	IDD		400	450	mA	【Note2】

【Note1】 Typical: Under 64 gray pattern
 Maximum: Under black pattern



(a)64 Gray Pattern



(b)Black Pattern

【Note2】 Typical: When VDD is 5V
 Maximum: When VDD is 4.5V

3.3 Power 、 signal sequence

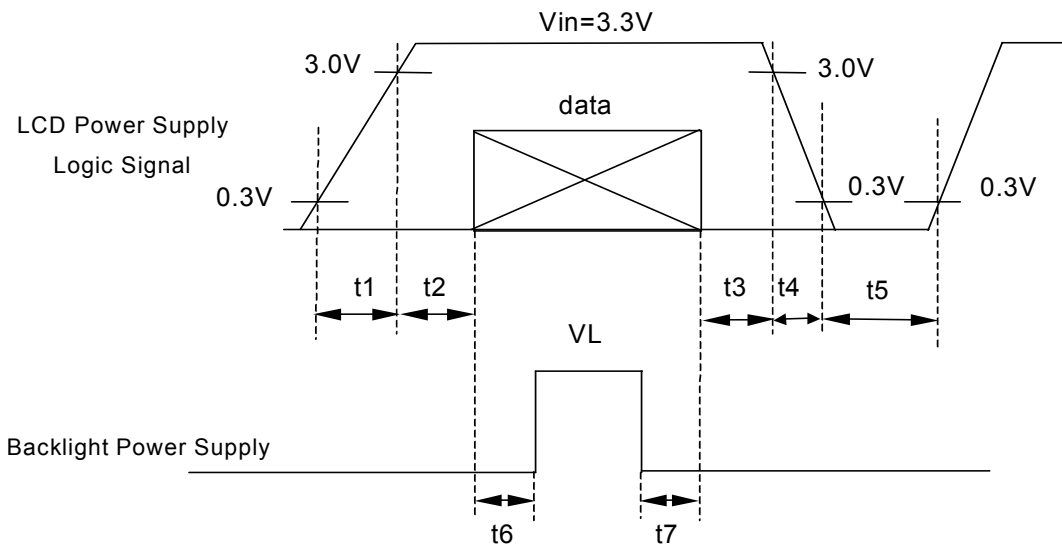

Data: RGB DATA, DCLK, DENA

- 0.5 $t_1 \le 10\text{ms}$ 200ms $\le t_5$
- 0 $t_2 \le 50\text{ms}$ 200ms $\le t_6$
- 0 $t_3 \le 50\text{ms}$ 200ms $\le t_7$
- 0 $t_4 \le 10\text{ms}$

4. INTERFACE CONNECTION

CN1 : STARCONN P/N (089N30-00R00-G2)

Pin NO.	SYMBOL	DESCRIPTION
1	AVSS	Power Ground
2	VCC	Power Supply for Digital circuit
3	VCC	Power Supply for Digital circuit
4	V_EDID	Power Supply for EDID circuit
5	ADJ	Adjust for LED brightness
6	CLK_EDID	EDID clock inputs
7	DATA_EDID	EDID data inputs
8	RXIN0-	Negative LVDS differential data inputs
9	RXIN0+	Positive LVDS differential data inputs
10	AVSS	Power Ground
11	RXIN1-	Negative LVDS differential data inputs
12	RXIN1+	Positive LVDS differential data inputs
13	AVSS	Power Ground
14	RXIN2-	Negative LVDS differential data inputs
15	RXIN2+	Positive LVDS differential data inputs
16	AVSS	Power Ground
17	RXCLK-	Negative LVDS differential clock inputs
18	RXCLK+	Positive LVDS differential clock inputs
19	AVSS	Power Ground
20	NC	NC
21	NC	NC
22	LR	Left / Right Display Control
23	UD	Up / Down Display Control
24	VLED	Power Supply for LED(Vled=5.0±0.5)
25	VLED	Power Supply for LED(Vled=5.0±0.5)
26	VLED	Power Supply for LED(Vled=5.0±0.5)
27	YD	Touch Panel control pin
28	XL	Touch Panel control pin
29	YU	Touch Panel control pin
30	XR	Touch Panel control pin

NOTE :

- 1) NC Pin must be retain, this pin can't contact GND or other signal.
- 2) GND Pin must ground contact , can not be floating.
- 3) ADJ adjust brightness to control Pin , Pulse duty the more big the more bright.

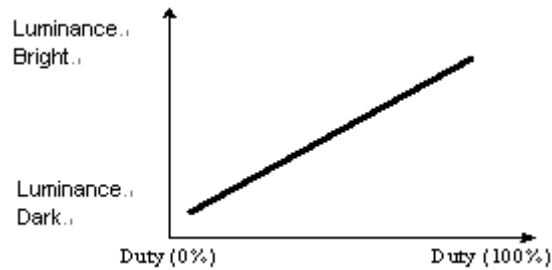

- 4) ADJ signal=0~3.3V , operation frequency : $25 \pm 5\text{KHz}$

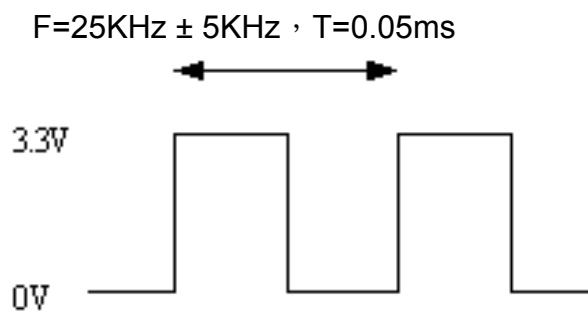

- 5) U/D and L/R are controled function

L/R	U/D	FUNCTION
1	0	Normally display
0	0	Left and Right opposite
1	1	Up and Down opposite
0	1	Left and Right opposite , Up and Down opposite

5. INPUT SIGNAL(DE ONLY MODE)

5.1 Timing Specification

ITEM			SYMBOL	MIN.	TYP.	MAX.	UNIT
LVDS input signal sequence	CLK Frequency		fCLKin	39	45	52	MHz
LCD input signal sequence (Input LVDS Transmitter)	Horizontal	Horizontal total Time	t_H	1150	1200	1250	tCLK
		Horizontal effective Time	t_{HA}	1024			tCLK
		Horizontal Blank Time	t_{HB}	126	176	226	tCLK
	Vertical	Frame	fV	55	60	65	Hz
		Vertical total Time	t_V	610	625	640	t_H
		Vertical effectiveTime	t_{VA}	600			t_H
		Vertical Blank Time	t_{VB}	10	25	50	t_H

5.2 Timing sequence (Timing chart)

5.2.1 Horizontal Timing Sequence

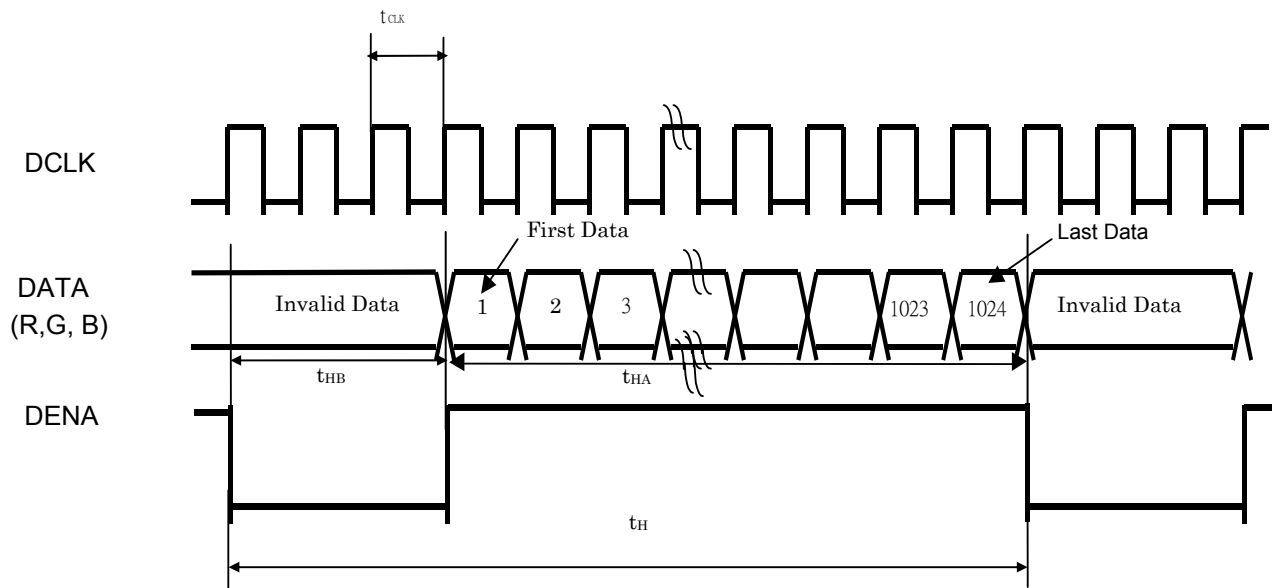

5.2.2 Vertical Timing Sequence

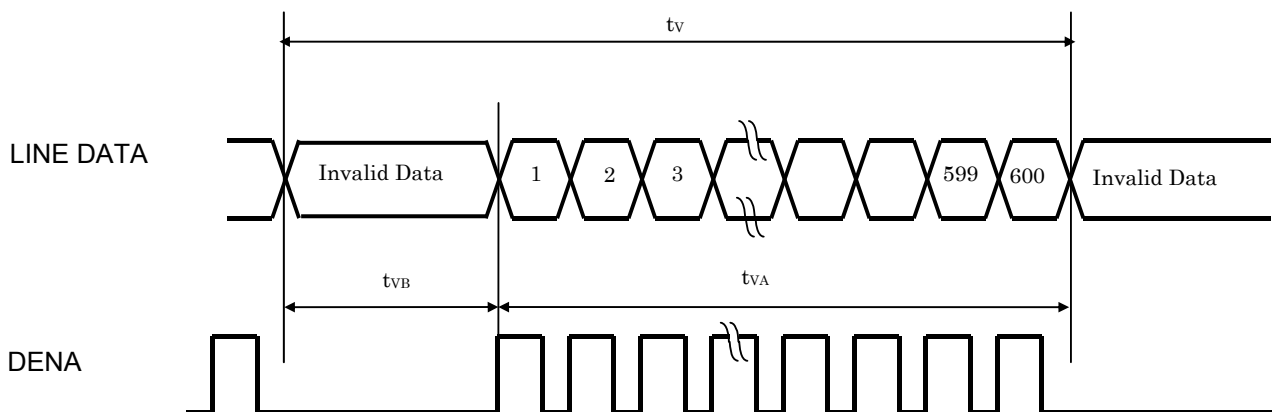

5.3 LVDS Input Data mapping

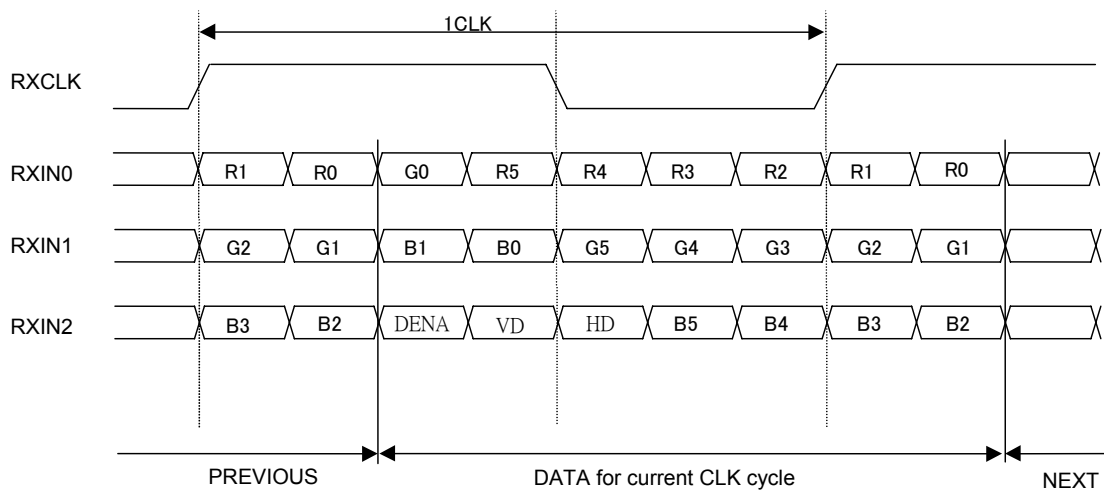

5.4 Color Data Assignment

COLOR	INPUT DATA	R DATA						G DATA						B DATA					
		R5	R4	R3	R2	R1	R0	G5	G4	G3	G2	G1	G0	B5	B4	B3	B2	B1	B0
		MSB					LSB	MSB					LSB	MSB					LSB
BASIC COLOR	BLACK	0	0	0	0	0	0	0	0	0	0	0	0	0	0	0	0	0	0
	RED(63)	1	1	1	1	1	1	0	0	0	0	0	0	0	0	0	0	0	0
	GREEN(63)	0	0	0	0	0	0	1	1	1	1	1	1	0	0	0	0	0	0
	BLUE(63)	0	0	0	0	0	0	0	0	0	0	0	0	1	1	1	1	1	1
	CYAN	0	0	0	0	0	0	1	1	1	1	1	1	1	1	1	1	1	1
	MAGENTA	1	1	1	1	1	1	0	0	0	0	0	0	1	1	1	1	1	1
	YELLOW	1	1	1	1	1	1	1	1	1	1	1	1	0	0	0	0	0	0
	WHITE	1	1	1	1	1	1	1	1	1	1	1	1	1	1	1	1	1	1
RED	RED(0)	0	0	0	0	0	0	0	0	0	0	0	0	0	0	0	0	0	0
	RED(1)	0	0	0	0	0	1	0	0	0	0	0	0	0	0	0	0	0	0
	RED(2)	0	0	0	0	1	0	0	0	0	0	0	0	0	0	0	0	0	0
	RED(62)	1	1	1	1	1	0	0	0	0	0	0	0	0	0	0	0	0	0
	RED(63)	1	1	1	1	1	1	0	0	0	0	0	0	0	0	0	0	0	0
GREEN	GREEN(0)	0	0	0	0	0	0	0	0	0	0	0	0	0	0	0	0	0	0
	GREEN(1)	0	0	0	0	0	0	0	0	0	0	0	1	0	0	0	0	0	0
	GREEN(2)	0	0	0	0	0	0	0	0	0	0	1	0	0	0	0	0	0	0
	GREEN(62)	0	0	0	0	0	0	1	1	1	1	1	0	0	0	0	0	0	0
	GREEN(63)	0	0	0	0	0	0	1	1	1	1	1	1	0	0	0	0	0	0
BLUE	BLUE(0)	0	0	0	0	0	0	0	0	0	0	0	0	0	0	0	0	0	0
	BLUE(1)	0	0	0	0	0	0	0	0	0	0	0	0	0	0	0	0	0	1
	BLUE(2)	0	0	0	0	0	0	0	0	0	0	0	0	0	0	0	0	1	0
	BLUE(62)	0	0	0	0	0	0	0	0	0	0	0	0	1	1	1	1	1	0
	BLUE(63)	0	0	0	0	0	0	0	0	0	0	0	0	1	1	1	1	1	1

NOTE :

(1) Definition of Gray Scale

color(n) : n is series of Gray Scale

The more n value is, the bright Gray Scale.

(2) Data:1-High,0-Low

6. CHARACTERISTIC OF TOUCH PANEL

6.1 Basis characteristic

ITEM	STANDARD	NOTE
Operating Voltage	5V(Typ)/7V(Max)	DC
Surface Treatment	Anti-Glare · Hardness : 3H	pencil hardness,45° /4.9Nt
Activation Force	Max. 100gf	Less than 100gf individual with stylus pen (R 0.8mm) or finger (R 8.0mm) ◦ Testing area : AA inside 2mm
Interface Type	4 Wire Resistive	
Resistance Between Terminals	X(Film side) : 200~900Ω Y(Glass side) : 200~900Ω	At the connector
Linearity	X(Film side) : ≤ 1.5% Y(Glass side) : ≤ 1.5%	Testing interval is 5mm with load 120g ◦ Testing area : AA inside 2mm
Insulation Resistance	Min. 20MΩ	At DC 25V

6.2 Design guideline for Touch-Panel

- (a) The Housing Cushion on touch-panel must be set at outside of T.P's view-area .
- (b) The Cushion material must be elastic material.
- (c) The housing must avoid to touch the T.P
- (d) To combine, the housing should not be stuck on T.P.
- (e) Example of housing design :

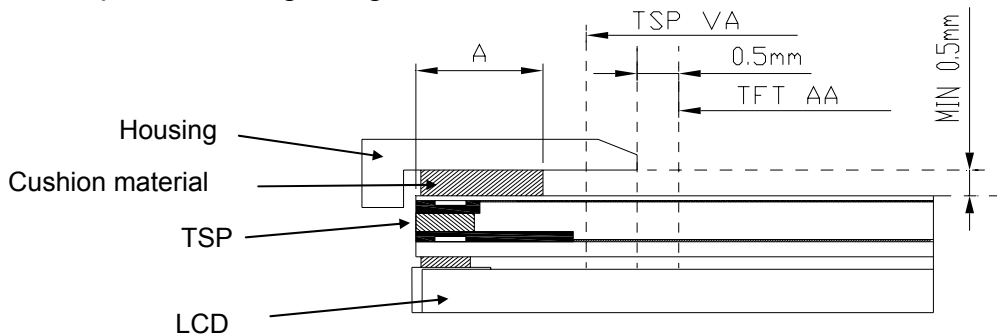

6.3 Circuit Diagram

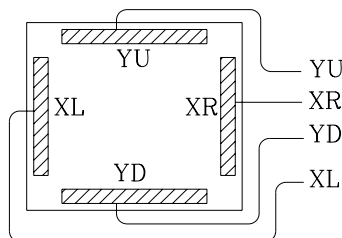

Circuit Diagram

Touch Panel Control

Pin No.	SYMBOL	FUNCTION
1	YU	Y axis resistance
2	XR	X axis resistance
3	YD	Y axis resistance
4	XL	X axis resistance

7. BLOCK DIAGRAM

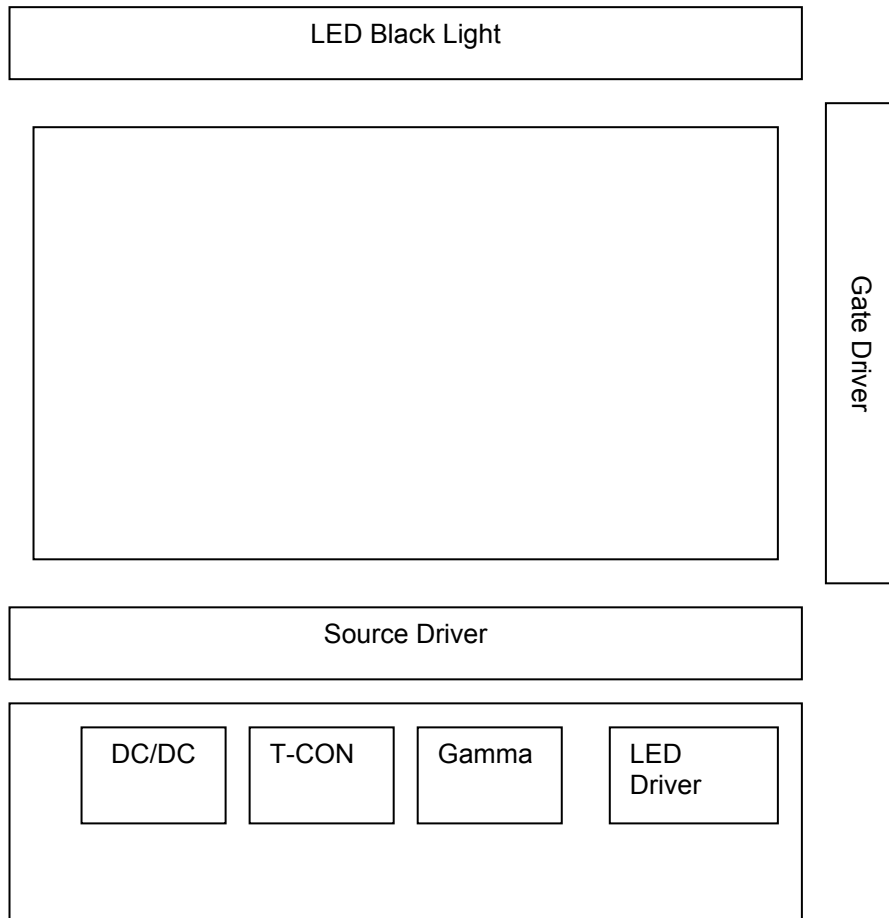

8. MECHANICAL DIMENSION

8.1 Front Side

[Unit : mm]

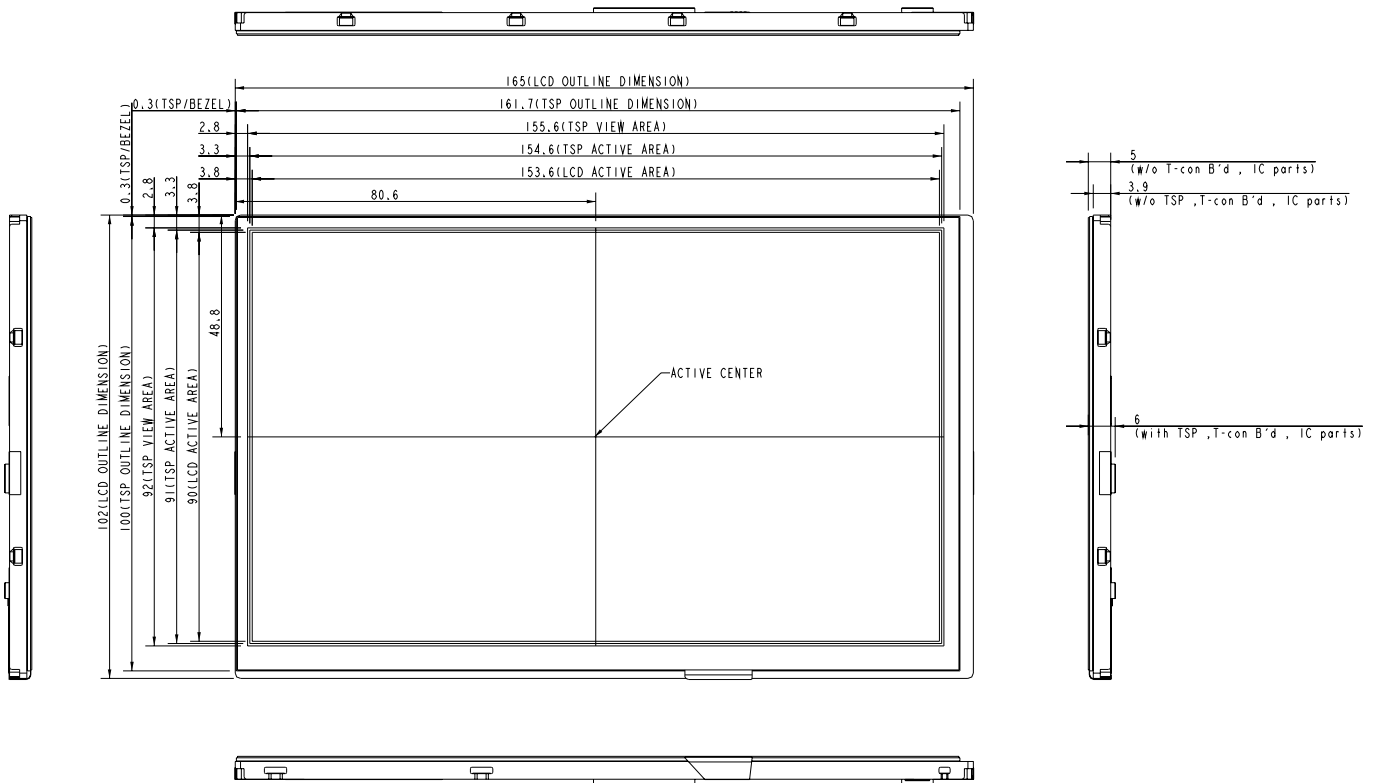

NOTE:General tolerance : ± 0.3mm

8.2 Rear Side

[Unit : mm]

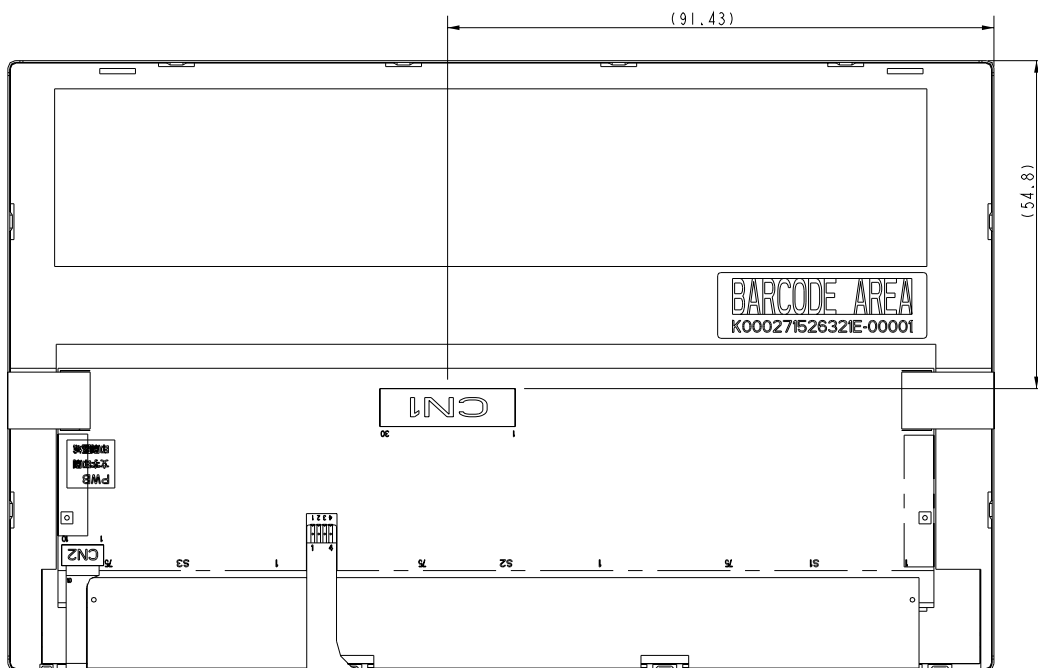

NOTE :

1. General tolerance : ± 0.3mm
2. LCD connector CN1(30pin) : STARCONN , P/N : 089N30-000R00-G2

9. OPTICAL CHARACTERISTICS

ITEM	SYMBOL	CONDITION	MIN.	TYP.	MAX.	UNIT	NOTE	
Constrast Ratio	CR	Point-5	---	400	--	--	*1)*2)*3)	
Luminance*)	Lw	Point-5	240	300	--	cd/m ²	*1)*3)	
Luminance Uniformity	ΔL		70	80	--	%	*1)*3)	
Response Time (White - Black)	Tr+ Tf	Point-5	--	20	30	ms	*1)*3)*5)	
Viewing Angle	Horizontal	ψ	CR \geq 10 Point-5	120	140	--	$^{\circ}$	*1)*2)*4)
	Vertical	θ		100	120	--	$^{\circ}$	*1)*2)*4)
Color Coordinate	White	Wx Wy	Point-5	0.273 0.289	0.313 0.329	0.353 0.369	*1)*3)	*1)*3)
	Red	Rx Ry		TBD	TBD	TBD		
	Green	Gx Gy		TBD	TBD	TBD		
	Blue	Bx By		TBD	TBD	TBD		

NOTE :

*1) Measure condition : 25°C \pm 2°C , 60 \pm 10%RH , under 10 Lux in the dark room. BM-5A (TOPCON) , viewing angle 2° , VCC=3.3V , Vadj=3.3V Duty 100%. test the panel after turning on 10 minute ago.

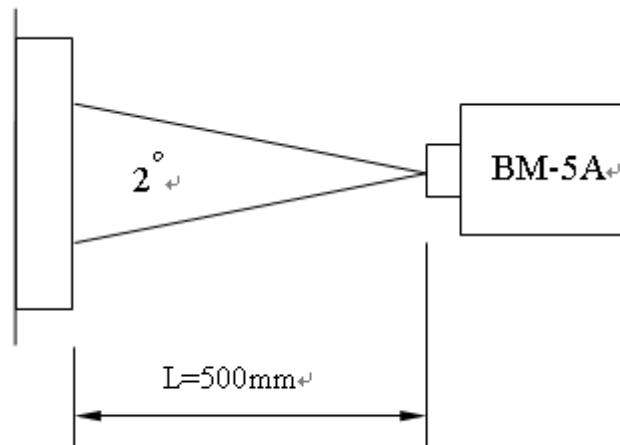

*2) Definition of contrast ratio :

Contrast Ratio (CR)= (White) Luminance of ON \div (Black) Luminance of OFF

*3) Definition of luminance :

Measure white luminance on the point 5 as figure8-1

Definition of Luminance Uniformity:

Measure white luminance on the point 1~9 as figure8-1

$$\Delta L = [L(\text{MIN})/L(\text{MAX})] \times 100$$

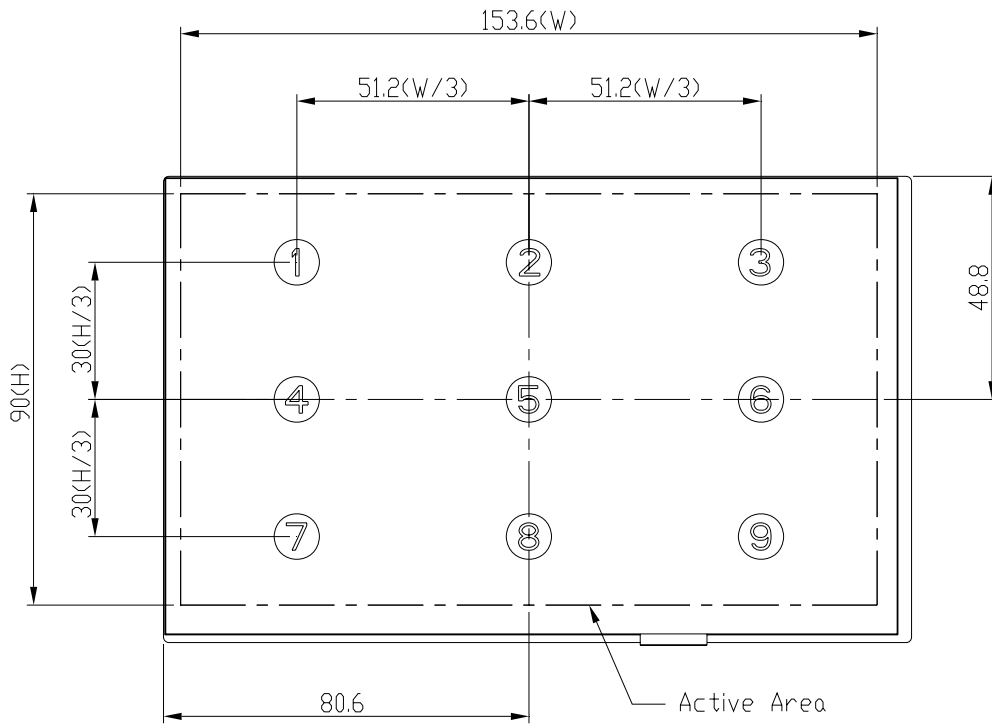

Fig8-1 Measuring point

*4) Definition of Viewing Angle(θ, ψ), refer to Fig8-2 as below :

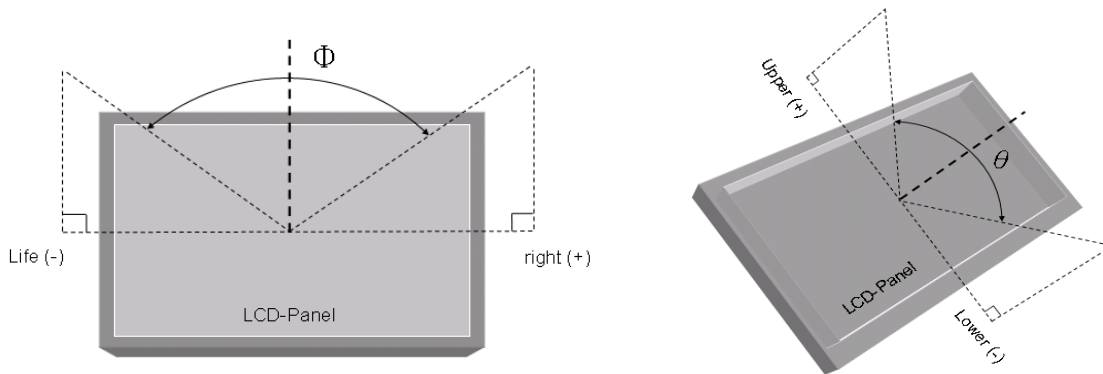

Fig8-2 Definition of Viewing Angle

*5) Definition of Response Time.(White-Black)

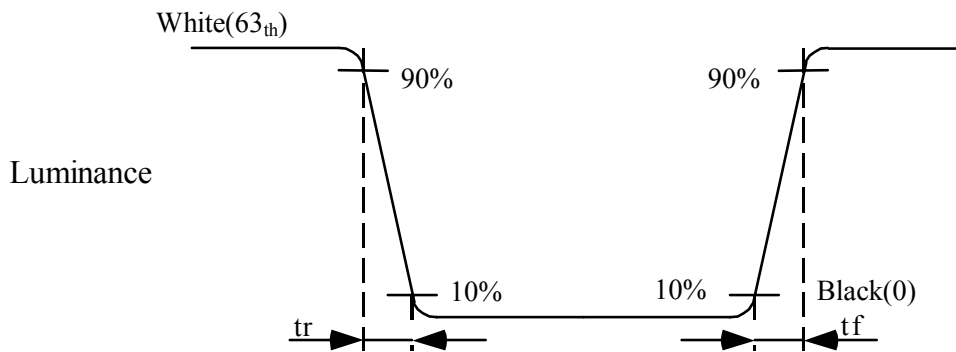

Fig8-3 Definition of Response Time(White-Black)

10. RELIABILITY TEST

10.1. Temperature and humidity

TEST ITEMS	CONDITIONS	NOTE
High Temperature Operation	70°C , 240Hrs	
High Temperature Storage	80°C , 240Hrs	
High Temperature High Humidity Operation	60°C , 90%RH , 240Hrs	No condensation
Low Temperature Operation	-20°C , 240Hrs	
Low Temperature Storage	-30°C , 240Hrs	
Thermal Shock	-30°C (0.5Hr) ~ 80°C(0.5Hr) 200 cycles	

10.2. Shock and Vibration

TEST ITEMS	CONDITIONS
Shock (Non-operation)	<ul style="list-style-type: none"> ● Shock level:980m/s²(equal to 100G) ● Waveform:half sinusoidal wave,6ms. ● Number of shocks:one shock input in each direction of three mutually perpendicular axes for a total of three shock inputs.
Vibration (Non-operation)	<ul style="list-style-type: none"> ● Frequency range:8~33.3Hz ● Stroke:1.3mm ● Vibration: sinusoidal wave, perpendicular axis(both x, z axis:2Hrs,y axis:4Hrs). ● Sweep:2.9G,33.3Hz-400Hz ● Cycle:15min

10.3 ESD

ITEM	CONDITION	NOTE
ESD	150pF , 330Ω , ±8KV&±15KV air test	【Note1】
	200pF , 0Ω , ±200V contact test	【Note2】

【Note1】 LCD glass and metal bezel

【Note2】 IF connector pins

10.4 Judgment standard

The Judgment of the above test should be made as follow:

Pass:Normal display image with no obvious non-uniformity and no line defect.Partial transformation of the module parts should be ignored.

Fail:No display image,obvious non-uniformity,or line defect.

11. APPEXNDIX EDID CODE TABLE

Byte#	Field Name and Comments	Value	Value
(Hex)		(Hex)	(Binary)
0		0	0000 0000
1		FF	1111 1111
2		FF	1111 1111
3		FF	1111 1111
4		FF	1111 1111
5		FF	1111 1111
6		FF	1111 1111
7		0	0000 0000
8	EISA manufacturer code = CPT (1 st byte)	0E	0000 1110
9	(2 nd byte)	14	0001 0100
0A	Product code LSB =	EF	1110 1111
0B	Product code MSB = (CLAA070NC0DCT=0751)	2	0000 0010
0C	ID (32-bit) serial number (preferred, but optional, zero if not used)	0	0000 0000
0D		0	0000 0000
0E		0	0000 0000
0F		0	0000 0000
10	Week of manufacture (preferred, but optional, zero if not used)	29	0010 0110
11	Year of manufacture (preferred, but optional, zero if not used)	12	0001 0000
12	EDID Structure version # = 1	1	0000 0001
13	EDID Revision # = 3	3	0000 0011
14	Video input definition (Digital I/P, non TMDS CRGB)	80	1000 0000
15	Max H image size (16.5) (rounded to cm)	11	0001 0001
16	Max V image size (10.2) (rounded to cm)	A	0000 1010
17	Display gamma =2.2 (=gamma*100)-100	78	0111 1000
18	Features (no DPMS, Active off, RGB, timing BLK1)	0A	0000 1100
19	Red/Green low Bits	AC	10101100
1A	Blue/White Low Bits	D4	11010100
1B	Red X Rx = 0.580 bits 9→2	94	10010100
1C	Red Y Ry = 0.334 bits 9→2	55	1010101
1D	Green X Gx = 0.354 bits 9→2	5A	1011010
1E	Green Y Gy = 0.574 bits 9→2	93	10010011
1F	Blue X Bx = 0.155 bits 9→2	27	100111
20	Blue Y By = 0.118 bits 9→2	1E	11110
21	White X Wx = 0.325 bits 9→2	53	1010011
22	White Y Wy = 0.340 bits 9→2	57	1010111
23	Established Timing I (800 * 600 * 60Hz) (V.6 remove simultaneously)	0	0000 0000
24	Established Timing II (1024 * 768 *60Hz) (V.6 remove simultaneously)	0	0000 0000
25	Manufacturer's Timings not used	0	0000 0000
26	Standard Timing Identification 1 not used	1	0000 0001
27	Standard Timing Identification 1 not used	1	0000 0001
28	Standard Timing Identification 2 not used	1	0000 0001

29	Standard Timing Identification 2 not used	1	0000 0001
2A	Standard Timing Identification 3 not used	1	0000 0001
2B	Standard Timing Identification 3 not used	1	0000 0001
2C	Standard Timing Identification 4 not used	1	0000 0001
2D	Standard Timing Identification 4 not used	1	0000 0001
2E	Standard Timing Identification 5 not used	1	0000 0001
2F	Standard Timing Identification 5 not used	1	0000 0001
30	Standard Timing Identification 6 not used	1	0000 0001
31	Standard Timing Identification 6 not used	1	0000 0001
32	Standard Timing Identification 7 not used	1	0000 0001
33	Standard Timing Identification 7 not used	1	0000 0001
34	Standard Timing Identification 8 not used	1	0000 0001
35	Standard Timing Identification 8 not used	1	0000 0001
36	Pixel Clock (LSB)	94	1100 0110
37	Pixel Clock = 45MHz 1024 * 600 @60Hz (MSB)	11	0001 1011
38	Horizontal Active = 1024 pixels Notes2 (lower 8 bits)	0	0000 0000
39	Horizontal Blanking = 176 pixels (lower 8 bits)	B0	1010 0000
3A	Horizontal Active : Horizontal Blanking(thbp) (upper 4:4 bits)	40	0101 0000
3B	Vertical Avtive =600 lines	58	0010 0000
3C	Vertical Blanking(tvbp) = 25 lines (DE Blanking min for DE-only panels) lines	19	0001 0111
3D	Vertical Active : Vertical Blanking(tvbp) (upper 4:4 bits)	20	0011 0000
3E	Horizontal Sync. Offset (thfp)= 48 pixels	30	0011 0000
3F	Horizontal Sync Pulse Width = 32 pixels(WHL)	20	0010 0000
40	Vertical Sync Offset (tvfp)= 3 lines, Sync Width(twvl) = 6 lines	36	0011 0110
41	Horizontal Vertical Sync Offset/Width upper 2bits	0	0000 0000
42	Horizontal Image Size = 153.6mm (lower 8bits)	9A	1001 1010
43	Vertical Image Size = 90mm (lower 8bits)	5A	0101 1010
44	Horizontal & Vertical Image Size (upper 4:4bits)	0	0001 0000
45	Horizontal Border = X (Zero for internal LCD)	0	0000 0000
46	Vertical Border = X (Zero for internal LCD)	0	0000 0000
47	Non-interlaced, Normal display, no stereo, Digital separate sync, H/V pol negatives	19	0001 1001
48	Flag	0	0000 0000
49	Flag	0	0000 0000
4A	Flag	0	0000 0000
4B	Data Type Tag: Descriptor Defined by Manufacture	0F	0000 FFFF
4C	Flag	0	0000 0000
4D	value=HSPWmin/2 (pixel clks) WHL	0	0000 0000
4E	value=HSPWmax/2 (pixel clks) WHL	0	0100 0100
4F	value= Thbp min/2 (pixel clks) (for DE-only timing also, with Thfp=0)	0	0000 0010
50	value= Thbp max/2 (pixel clks) (for DE-only timing also, with Thfp=0)	0	1001 0100
51	value=VSPWmin/2 (line pulses) WVL	0	0000 0000
52	value=VSPWmax/2 (line pulses) WVL	0	0000 0011
53	value= Tvbp min/2	0	0000 0000
54	value= Tvbp max/2	0	0001 0001

55	Thp min=value*2+HApixelClks (pixel clks) Note2	20	0010 0000
56	Thp max=value*2+HApixelClks (pixel clks) Note2	6E	0110 1110
57	Tvp min=value*2+Valines (line pulses)	5	0000 0101
58	Tvp max=value*2+Valines (line pulses)	F	0000 1111
59	Module revision	0	0000 0000
5A	Flag	0	0000 0000
5B	Flag	0	0000 0000
5C	Flag	0	0000 0000
5D	Data Type Tag: (Monitor) ASCII String	FE	1111 1110
5E	Flag	0	0000 0000
5F	"C",67	43	0101 0000
60	"P",80	50	0101 1001
61	"T",84	54	0011 0110
62		20	0010 0000
63		20	0010 0000
64		20	0010 0000
65		20	0010 0000
66		20	0010 0000
67		20	0010 0000
68		20	0010 0000
69		20	0010 0000
6A		20	0010 0000
6B	(if <13 char, then terminate with ASCII code 0Ah, and set remaining char = 20h)	20	0010 0000
6C	Flag	0	0000 0000
6D	Flag	0	0000 0000
6E	Flag	0	0000 0000
6F	Data Type Tag: (Monitor) ASCII String	FE	1111 1110
70	Flag	0	0000 0000
71	"C",67	43	0100 0011
72	"L",76	4C	0100 1100
73	"A",65	41	0100 0001
74	"A",65	41	0100 0001
75	"0",48	30	0011 0000
76	"7",55	37	0011 0111
77	"0",48	30	0011 0000
78	"N",78	4E	0100 1110
79	"C",67	43	0100 0011
7A	"0",48	30	0011 0000
7B	"D",68	44	0100 0100
7C	"C",67	43	0100 0011
7D	"T",84	54	0101 0100
7E	Extension Flag (# of optional 128-byte EDID extension blocks to follow, typ=0)	0	0000 0000
7F	Checksum (the 1-byte sum of all 128 bytes in this EDID block shall equal zero)	71	0000 0100