



# Chunghwa Picture Tubes, Ltd.

## Technical Specification

CPT TFT-LCD  
**CLAA101FP07**

APPROVED BY	CHECKED BY	PREPARED BY

Prepared by : Design General Division

**CHUNGHWA PICTUER TUBES, LTD.**

No. 1, Huaying Rd., Sanho Tsun, Lungtan Shiang, Taoyuan, Taiwan, 325, R.O.C.  
TEL: +886-3-4805678 FAX: +886-3-4800589

Doc. No:	<b>CLAA101FP07-Tentative</b>	Issue Date:	<b>2013/02/28</b>
----------	------------------------------	-------------	-------------------

**Title : CLAA101FP07**

**Technical Specification**

**Modification Record List**

<b>NO.</b>	<b>Issue Date</b>	<b>Modification Index</b>
1	2013/02/28	First Edition

www.panelook.com

**Title : CLAA101FP07      Technical Specification**

**Table of Content**

NO.	Table of Content	Page
1	OVERVIEW	4
2	ABSOLUTE MAXIMUM RATINGS	5
3	ELECTRICAL CHARACTERISTICS	6
4	CONNECTOR INTERFACE PIN & FUNCTION	11
5	INTERFACE TIMING CHART	12
6	BLOCK DIAGRAM	14
7	MECHANICAL SPECIFICATION	15
8	OPTICAL CHARACTERISTICS	17
9	RELIABILITY TEST CONDITIONS	21

**Title : CLAA101FP07****Technical Specification****1. OVERVIEW**

**CLAA101FP07** is 10.1" color (16 : 10) TFT-LCD (Thin Film Transistor Liquid Crystal Display) module composed of LCD panel, driver ICs, control circuit and backlight. By applying 8 bit digital data, 1920×RGB (3) ×1200, 16.7M-color images are displayed on the 10.1" diagonal screen. General specifications are summarized in the following table :

ITEM	SPECIFICATION
Display Area	216.576 (H) x 135.36 (V) (mm) (10.1-inch diagonal)
Number of Pixels	1920×RGB (3) ×1200
Pixel Pitch	0.1128 (H) × 0.1128 (V) (mm)
Color Pixel Arrangement	RGB vertical stripe
Display Mode	HFFS
Number of Colors	16,777,216
Interface Signal	eDP 1.2
Gamut	50% (Typ)
Response Time	30ms (Typ) / 40ms (Max)
Surface Treatment	HC-LR
Viewing Angle	80°、80° / 80°、80° (Min) 85°、85° / 85°、85° (Typ.)
Brightness	450nits typ/400 nits min
Uniformity	9point : 78%(min)
Consumption of Power	Panel 1W; BL 3.28(With IC Driver)
Module Size	229(W)×153 (H)×2.5 (D) (mm) (Typical) (w/o pcb))
Module Weight	135g(max)

The LCD Products listed on this document are not suitable for use of aerospace equipment, submarine cable, and nuclear reactor control system and life support systems. If customers intend to use these LCD products for applications listed above or those not included in the "Standard" list as follows, please contact our sales in advance.

Standard : Computer, Office equipment, Communication equipment, Test and Measurement equipment, Machine tool, Industrial robot, Audio and Visual equipment, Other consumer products.

**Title : CLAA101FP07      Technical Specification**

**2. ABSOLUTE MAXIMUM RATINGS**

The following are maximum value, which if exceeded, may cause faulty operation or damage to the unit.

ITEM	SYMBOL	MIN	MAX	UNIT	NOTE
LCD Power Voltage	Vin	0	4.0	V	
LED Driver Input Voltage	VBL+	0	25	V	
Operation Temperature	Top	0	50	°C	*1).*2).*3).*4)
Storage Temperature	Tstg	-25	65	°C	*1).*2).*3)

**【Note】**

- \*1) The relative temperature and humidity range are as below sketch, 90%RH Max. ( $T_a \leq 40^\circ\text{C}$ )
- \*2) The maximum wet bulb temperature  $\leq 39^\circ\text{C}$  ( $T_a > 40^\circ\text{C}$ ) and without dewing.
- \*3) If product in environment which over the definition of the relative temperature and humidity out of range too long, it will affect visual of LCD.
- \*4) If you operate LCD in normal temperature range, the center surface of panel should be under  $50^\circ\text{C}$ .

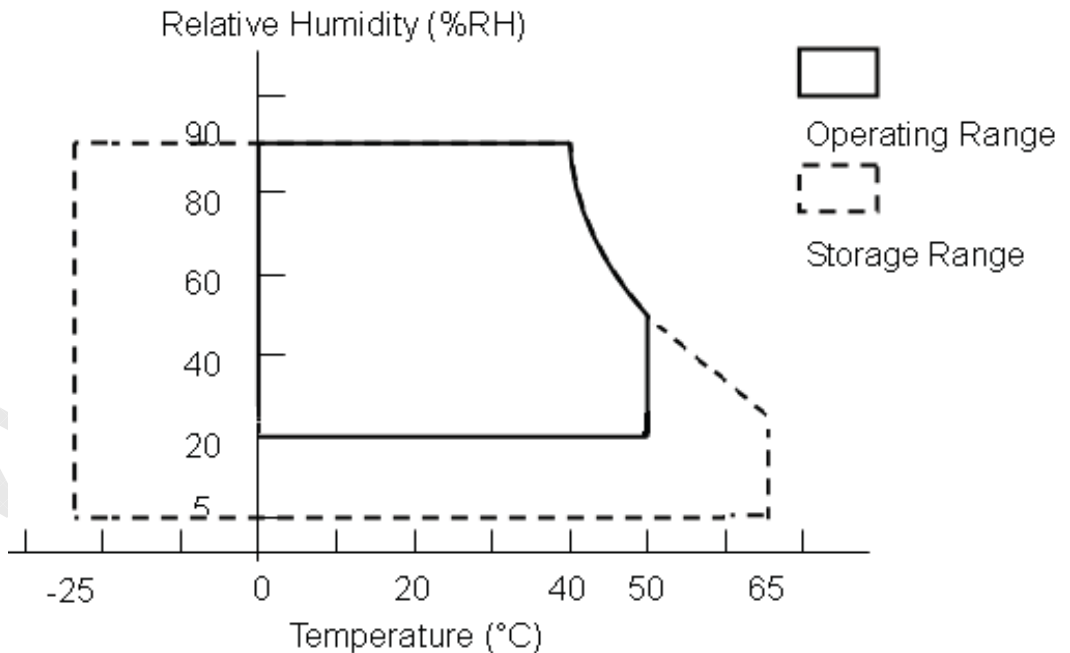

**Title : CLAA101FP07      Technical Specification**

**3. ELECTRICAL CHARACTERISTICS**

**(A) TFT LCD**

ITEM	SYMBOL	MIN	TYP	MAX	UNIT	NOTE
LCD Power Voltage	Vin	3.0	3.3	3.6	V	*1)
LCD Power Current	Iin	-	400	600	mA	*2)
Rush Current	Irush	-	-	3	A	*4)

**【Note】**

\*1) Power Sequence :

- 0.01 ms < t1 ≦ 50 ms                      500 ms ≦ t4
- 100 ms ≦ t2 ≦ 150 ms                      200 ms ≦ t5
- 0.01 ms < t3 ≦ 50 ms                      200 ms ≦ t6

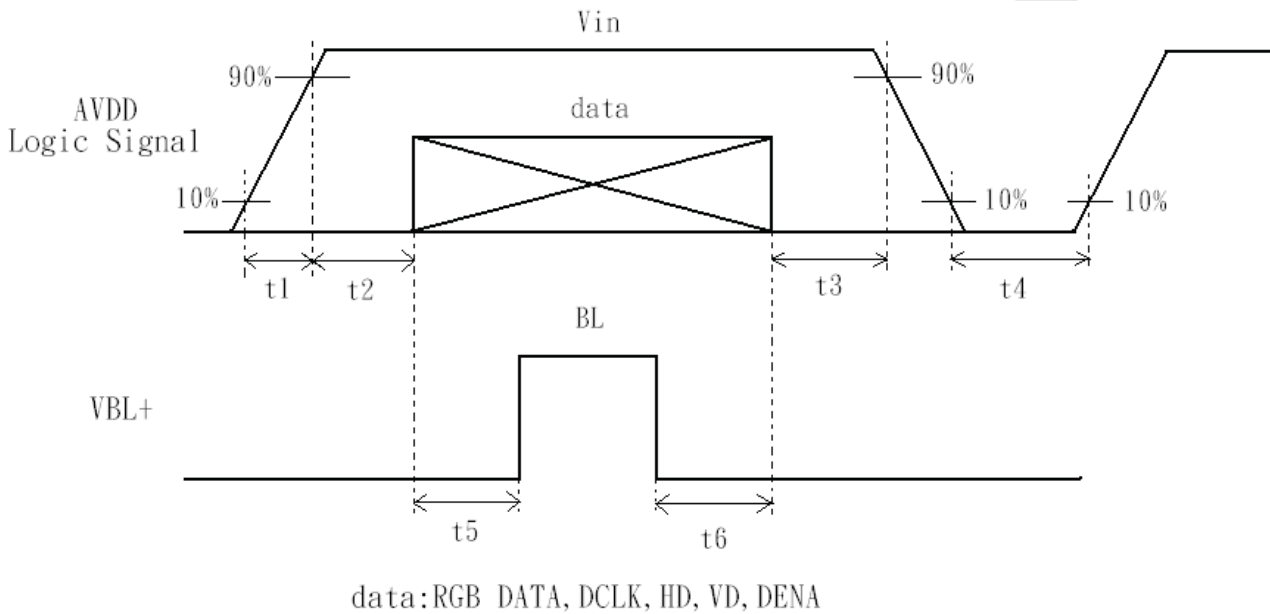

**Vin-dip state**

- (1)when 3.0V > Vin ≧ 2.7V , td ≦ 10 ms.
- (2)when Vin < 2.7V , Vin-dip condition should as the Vin-turn-off condition.

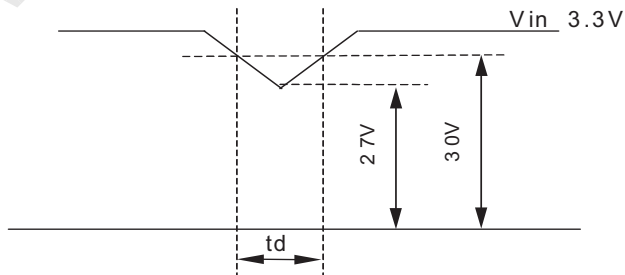

**Title : CLAA101FP07      Technical Specification**

\*2) Max value is White Pattern : 1200 line mode.

Circuit condition (Max) : VCC=3.3 V , f<sub>V</sub>=60 Hz , f<sub>H</sub>=74.1 kHz , f<sub>CLK</sub>=154 MHz.

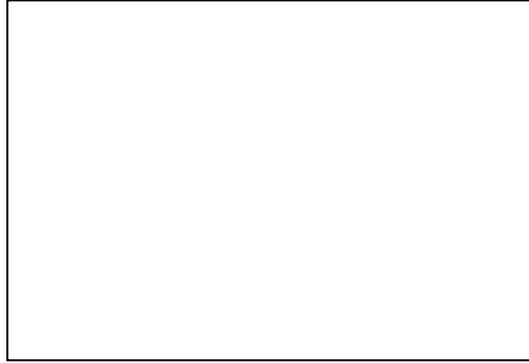

\*4) Irush measure condition

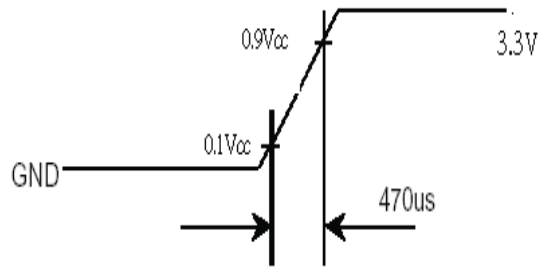
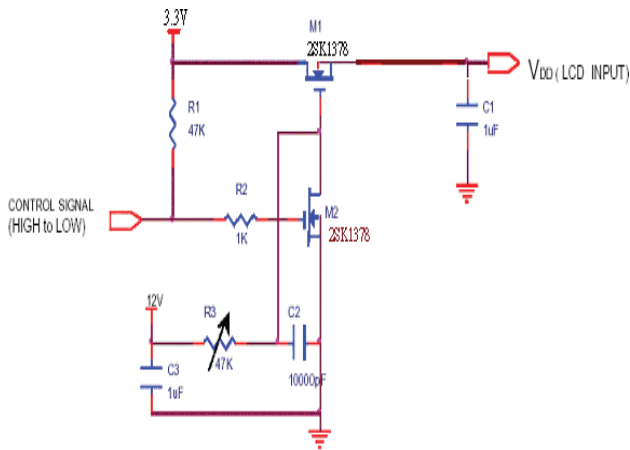

**(B) BACK LIGHT**

(a.) ELECTRICAL CHARACTERISTICS

Ta=25°C

ITEM	SYMBOL	MIN	TYP	MAX	UNIT	NOTE
LED Driver Input Voltage	VBL+	7.0	8.0	19	V	
LED Driver Input Current	IBL+	-		700	mA	*1)
Forward Voltage	V <sub>F</sub>	2.82	2.92	3.02	V	*2) I <sub>F</sub> =22mA
Forward Current	I <sub>F</sub>	-	22	-	mA	*2) I <sub>F</sub> =22mA
Power Consumption	PLED			2.79	W	*2) I <sub>F</sub> =22mA
PWM Frequency	PWM_BL	100	-	1000	Hz	
Duty ratio	Dim	10	-	100	%	

**Title : CLAA101FP07      Technical Specification**

(b.) LED LIFE – TIME

ITEM	CONDITION	MIN	TYP	MAX	UNIT	NOTE
Life Time	I <sub>F</sub> =20mA、Ta=25°C	15000			hrs	*4)

(c.) LED ON/OFF Sequence :

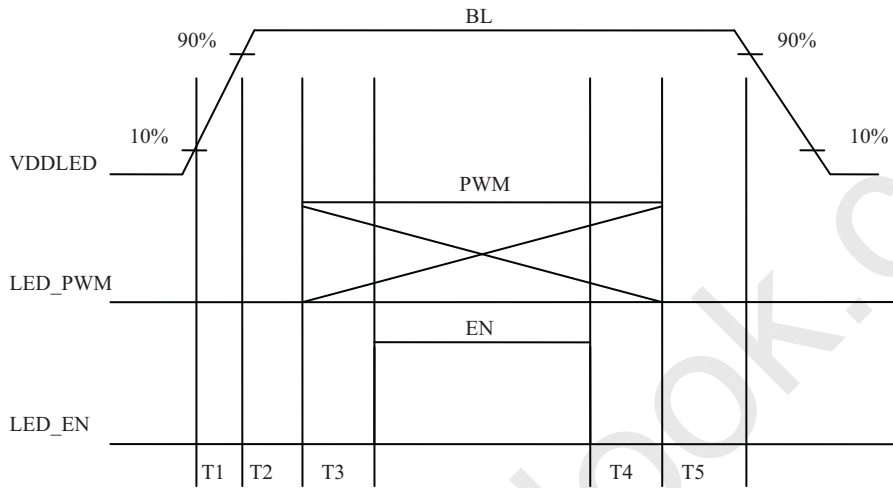

- 0.5ms ≧ T1 ≧ 10ms
- 10ms ≧ T2
- 10ms ≧ T3
- 0ms ≧ T4
- 10ms ≧ T5

Note:

The LED power variation spec. is defined as the following figure.

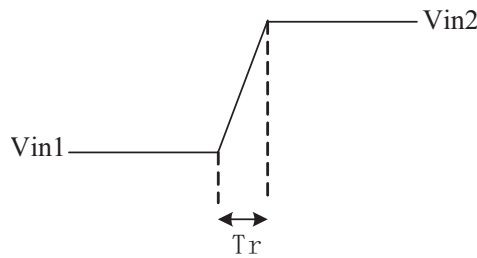

When LED input voltage is from Vin1 up to Vin2, the slew rate should be less than 20 V/ms.

Slew rate = (Vin2-Vin1) / Tr , Vin2 > Vin1



**Title : CLAA101FP07****Technical Specification**

- \*1) Maximum LED Driver Input Current at 12V Input Voltage/PWM Duty 100%.
- \*2) Measure method : a. LED current is measured by utilizing a current meter as show below.  
b. System power PLED is measured at input voltage 12V.

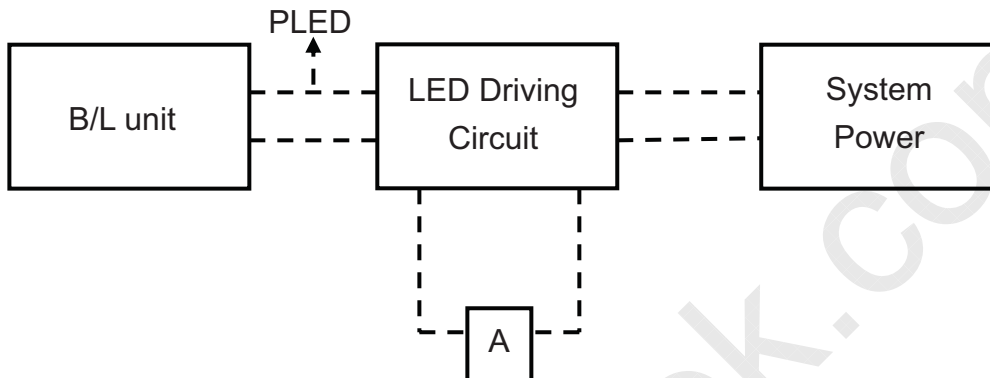

- \*2) Calculator value for reference  $I_F \times V_F \times N = P_{LED}$
- \*3) Life time means that estimated time to 50% degradation of initial luminous intensity.

**Title : CLAA101FP07****Technical Specification****4. Connector Interface PIN & Function****CN (Interface signal)**

Outlet connector: 20455-030E-12 (I-PEX)

➤ Pin No. is 30 pin define of Plug connector

PIN NO	SYMBOL	DESCRIPTION
1	NC	Reserved
2	H_GND	High Speed Ground
3	LAN1_N	Complement Signal Link Lane 1
4	LAN1_P	True Signal Link Lane 1
5	H_GND	High Speed Ground
6	LAN0_N	Complement Signal Link Lane 0
7	LAN0_P	True Signal Link Lane 0
8	H_GND	High Speed Ground
9	AUX_P	True Signal Auxiliary Ch.
10	AUX_N	Complement Signal Auxiliary Ch.
11	H_GND	High Speed Ground
12	VCC	LCD logic and driver power(Power Supply,3.3V typocal)
13	VCC	LCD logic and driver power(Power Supply,3.3V typocal)
14	NC	Reserved (BIST function)
15	LCD_GND	LCD logic and driver ground
16	NC	Reserved
17	HPD	HPD signal pin
18	BL_GND	Backlight ground
19	BL_GND	Backlight ground
20	BL_GND	Backlight ground
21	BL_GND	Backlight ground
22	BL_ENABLE	Backlight On/Off enable pin(+3.3V Input)
23	BL_PWM_DIM	System PWM signal input for dimming(+3.3V Swing)
24	SDA	Reserved(For EDID SDA)
25	SCL	Reserved(For EDID SCL)
26	BL_PWR	Backlight power (7V - 19V LED power)
27	BL_PWR	Backlight power (7V - 19V LED power)
28	BL_PWR	Backlight power (7V - 19V LED power)
29	BL_PWR	Backlight power (7V - 19V LED power)
30	LCD_GND	LCD logic and driver ground

**Title : CLAA101FP07      Technical Specification**

**5. INTERFACE TIMING CHART**

5.1 Timing sequence(Timing chart)

(1) eDP input time sequence and signal definite :

The VESA Display Port related AC specification is compliant with the specification in the VESA Display Port Standard v1.2a.

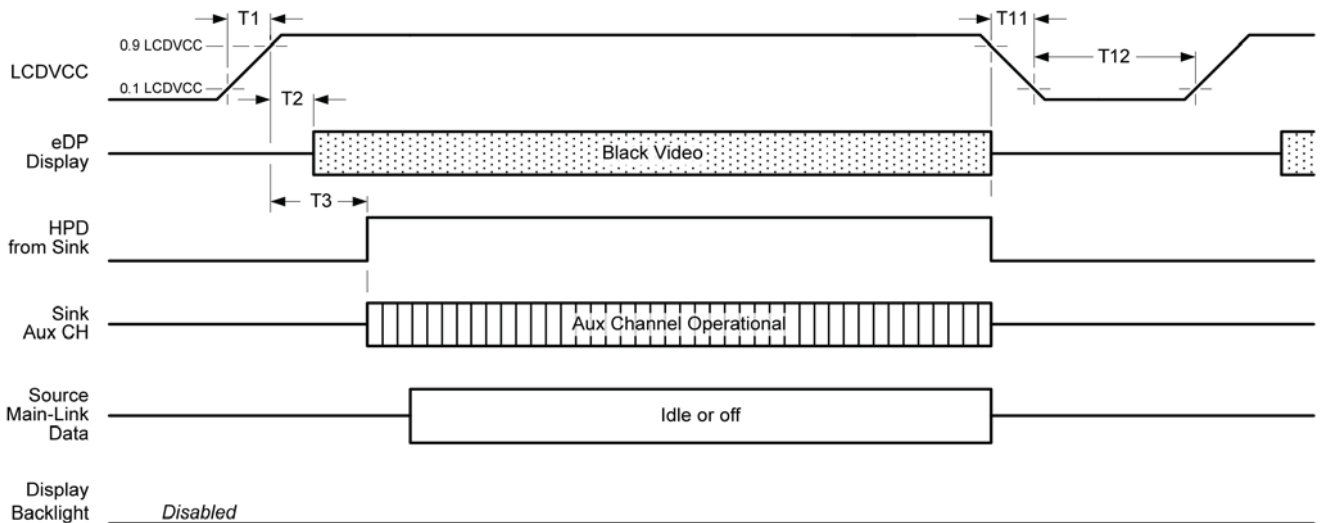
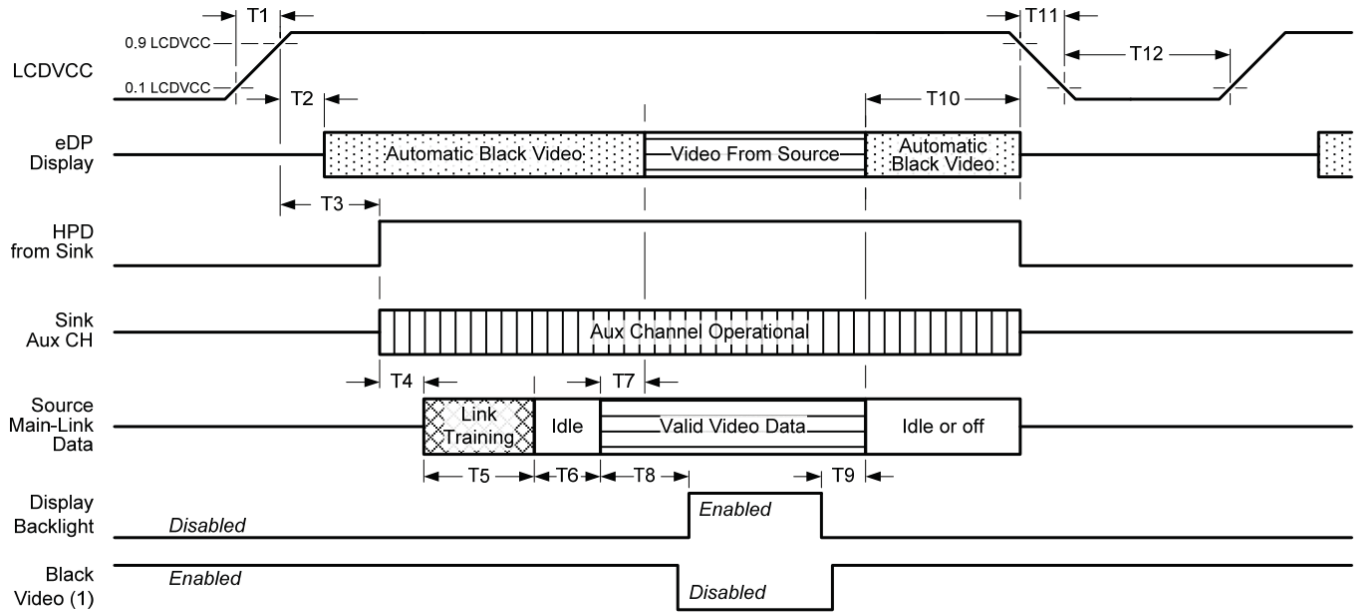

**Title : CLAA101FP07****Technical Specification**

Timing Parameter	Description	Required By	Limits		Notes
			Min	Max	
T1	Power rail rise time, 10% to 90%	Source	0.5ms	10ms	
T2	Delay from LCDVCC to automatic black video generation	Sink	0ms	200ms	Automatic black video generation prevents display noise until valid video data is received from the Source (see note 1 below)
T3	Delay from LCDVCC to HPD high	Sink	0ms	200ms	Sink AUX Channel must be operational upon HPD high
T4	Delay from HPD high to link training initialization	Source	-	-	Allows for Source to read Link capability and initialize
T5	Link training duration	Source	-	-	Dependant on Source link training protocol
T6	Link idle	Source	-	-	Min accounts for required BS-Idle pattern. Max allows for Source frame synchronization.
T7	Delay from valid video data from Source to video on display	Sink	0ms	50ms	Max value allows for Sink to validate video data and timing. At the end of T7, Sink will indicate the detection of valid video data by setting the SINK_STATUS bit to logic 1 (DPCD 00205h, bit 0), and Sink will no longer generate automatic black video.
T8	Delay from valid video data from Source to backlight enable	Source	-	-	Source must assure display video is stable
T9	Delay from backlight disable to end of valid video data	Source	-	-	Source must assure backlight is no longer illuminated (see note 1 below). At the end of T9, Sink will indicate the detection of no valid video data by setting the SINK_STATUS bit to logic 0 (DPCD 00205h, bit 0), and Sink will automatically display black video.
T10	Delay from end of valid video data from Source to power off	Source	0ms	500ms	
T11	Power rail fall time, 90% to 10%	Source	-	10ms	
T12	Power off time	Source	500ms	-	

**Title : CLAA101FP07      Technical Specification**

**5.2 DATA mapping**

Color	Input Data	R DATA						G DATA						B DATA					
		R5	R4	R3	R2	R1	R0	G5	G4	G3	G2	G1	G0	B5	B4	B3	B2	B1	B0
		MSB					LSB	MSB					LSB	MSB					LSB
Basic Color	Black	0	0	0	0	0	0	0	0	0	0	0	0	0	0	0	0	0	0
	Red(63)	1	1	1	1	1	1	0	0	0	0	0	0	0	0	0	0	0	0
	Green(63)	0	0	0	0	0	0	1	1	1	1	1	1	0	0	0	0	0	0
	Blue(63)	0	0	0	0	0	0	0	0	0	0	0	0	1	1	1	1	1	1
	Cyan	0	0	0	0	0	0	1	1	1	1	1	1	1	1	1	1	1	1
	Magenta	1	1	1	1	1	1	0	0	0	0	0	0	1	1	1	1	1	1
	Yellow	1	1	1	1	1	1	1	1	1	1	1	1	0	0	0	0	0	0
	White	1	1	1	1	1	1	1	1	1	1	1	1	1	1	1	1	1	1
RED	RED(0)	0	0	0	0	0	0	0	0	0	0	0	0	0	0	0	0	0	0
	RED(1)	0	0	0	0	0	1	0	0	0	0	0	0	0	0	0	0	0	0
	RED(2)	0	0	0	0	1	0	0	0	0	0	0	0	0	0	0	0	0	0
	RED(62)	1	1	1	1	1	0	0	0	0	0	0	0	0	0	0	0	0	0
	RED(63)	1	1	1	1	1	1	0	0	0	0	0	0	0	0	0	0	0	0
Green	Green(0)	0	0	0	0	0	0	0	0	0	0	0	0	0	0	0	0	0	0
	Green(1)	0	0	0	0	0	0	0	0	0	0	0	1	0	0	0	0	0	0
	Green(2)	0	0	0	0	0	0	0	0	0	0	1	0	0	0	0	0	0	0
	Green(62)	0	0	0	0	0	0	1	1	1	1	1	0	0	0	0	0	0	0
	Green(63)	0	0	0	0	0	0	1	1	1	1	1	1	0	0	0	0	0	0
Blue	Blue(0)	0	0	0	0	0	0	0	0	0	0	0	0	0	0	0	0	0	0
	Blue(1)	0	0	0	0	0	0	0	0	0	0	0	0	0	0	0	0	0	1
	Blue(2)	0	0	0	0	0	0	0	0	0	0	0	0	0	0	0	0	1	0
	Blue(62)	0	0	0	0	0	0	0	0	0	0	0	0	1	1	1	1	1	0
	Blue(63)	0	0	0	0	0	0	0	0	0	0	0	0	1	1	1	1	1	1

**【Note】**

- 1) Gray level:  
 Color(n) : n is level order; higher n means brighter level.
- 2) DATA:  
 1: high , 0: low

**Title : CLAA101FP07      Technical Specification**

**5.3 Timing Chart**

ITEM			SYMBOL	MIN	TYP	MAX	UNIT	
LCD Timing	Frame Rate		-	60	60	60	Hz	
	DCLK	Frequency	$f_{CLK}$	-	154	-	MHz	
		Period	$t_{CLK}$	-	6.5	-	ns	
	DENA	Horizontal	Horizontal total time	$t_H$	-	2080	-	$t_{CLK}$
			Horizontal Active time	$t_{HA}$	1920	1920	1920	$t_{CLK}$
			Horizontal Blank time	$t_{HB}$	-	160	-	$t_{CLK}$
		Vertical	Vertical total time	$t_V$	-	1235	-	$t_H$
			Vertical Active time	$t_{VA}$	1200	1200	1200	$t_H$
			Vertical Blank time	$t_{VB}$	-	35	-	$t_H$

**【Note】**

- \*1) DENA (DATA ENABLE) usually is positive.
- \*2) During the whole blank period, DCLK should keep input.

**Title : CLAA101FP07**

**Technical Specification**

**6. BLOCK DIAGRAM**

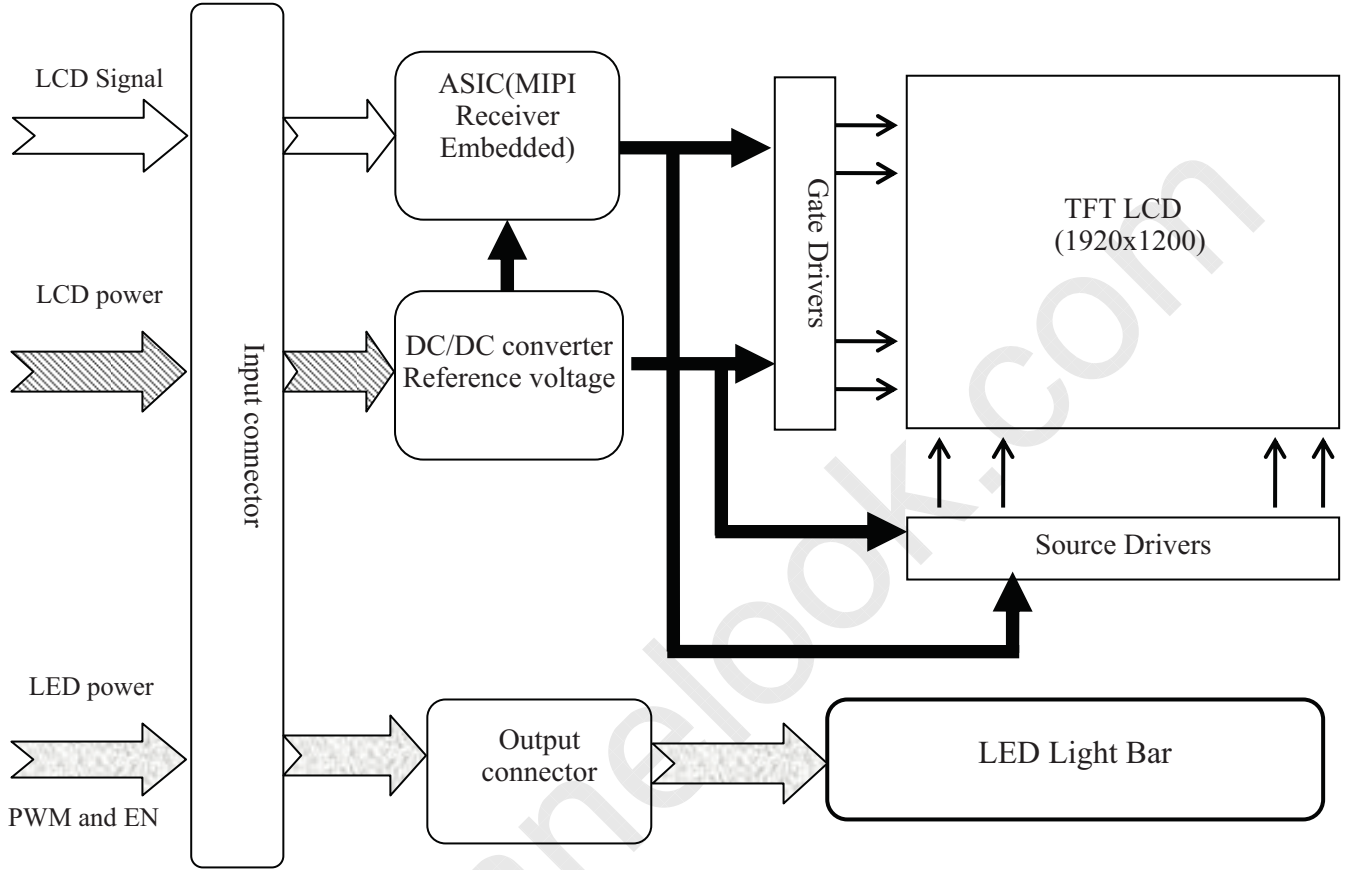

Title : **CLAA101FP07**

**Technical Specification**

**7. MECHANICAL SPECIFICATION**

**(1) Front side**

The tolerance, not show in the figure, is  $\pm 0.5$  mm.

[Unit : mm]

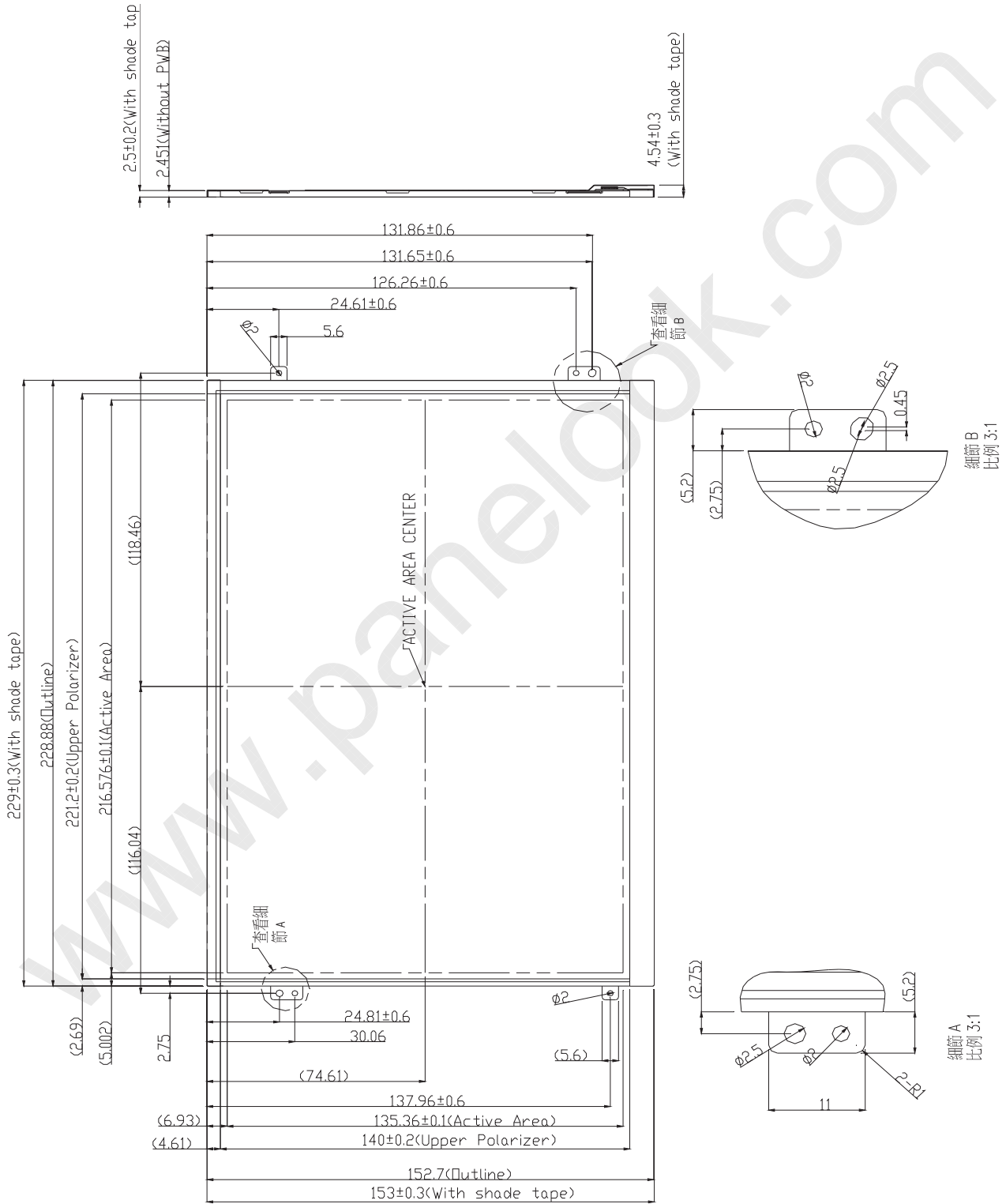



**Title : CLAA101FP07**

**Technical Specification**

**(2) Rear side**

The tolerance, not show in the figure, is  $\pm 0.5$  mm.

[Unit : mm]

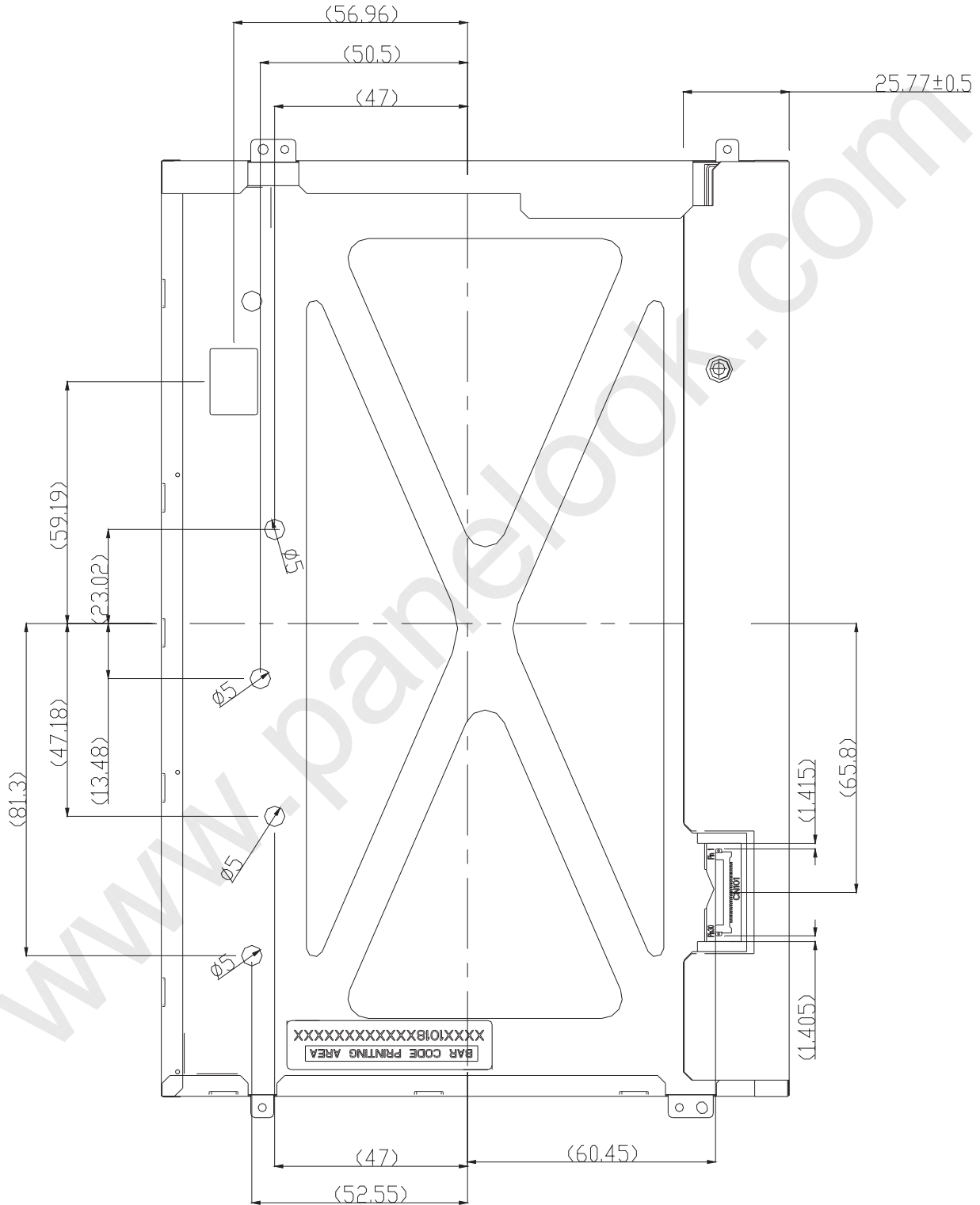

**Title : CLAA101FP07      Technical Specification**

**8. OPTICAL CHARACTERISTICS**

**Ta=25°C , VDD=3.3V**

ITEM	SYMBOL	CONDITION	MIN	TYP	MAX	UNIT	NOTE	
Contrast Ratio	CR	$\theta = \psi = 0^\circ$	600	800	--	--	*1) 2)	
Luminance (center)	L	$\theta = \psi = 0^\circ$	400	450	--	cd/m <sup>2</sup>	*1) 3)	
Uniformity(9P)	$\Delta L$	$\theta = \psi = 0^\circ$	78	--	--	%	*1) 3)	
Response Time	Tr	$\theta = \psi = 0^\circ$	--	30	40	ms	*5)	
	Tf							
Cross Talk	CT	$\theta = \psi = 0^\circ$	--	--	1.0	%	*6)	
View Angle	Horizontal	$\psi$	CR $\geq$ 10	80/-80	85/-85	--	°	*4)
	Vertical	$\theta$		80/-80	85/-85	--	°	*4)
Color Coordinate	W	x	$\theta = \psi = 0^\circ$	0.283	0.313	0.343	*3)	
		y		0.299	0.329	0.359		
	R	x		0.540	0.570	0.600		
		y		0.294	0.324	0.354		
	G	x		0.301	0.331	0.361		
		y		0.548	0.578	0.608		
	B	x		0.129	0.159	0.189		
		y		0.075	0.105	0.135		
Gamut		$\theta = \psi = 0^\circ$	45	50	--	%		
Gamma	$\gamma$	GL	2.0	2.2	2.4		*7)	

Color coordinate and color gamut are measured by SRUL1R, response time is measured by TRD-100, and all the other items are measured by BM-5A (TOPCON). All these items are measured under the dark room condition (no ambient light).

Measurement Condition: IL= 22mA (each LED)

**Definition of these measurement items is as follows:**

**\*1) Setup of Measurement Equipment**

The LCD module should be turn-on to a stable luminance level to be reached. The measurement should be executed after lighting Backlight for 20 minutes and in a dark room.

**Title : CLAA101FP07      Technical Specification**

**\*2) Definition of Contrast Ratio**

CR=ON (White) Luminance/OFF (Black) Luminance

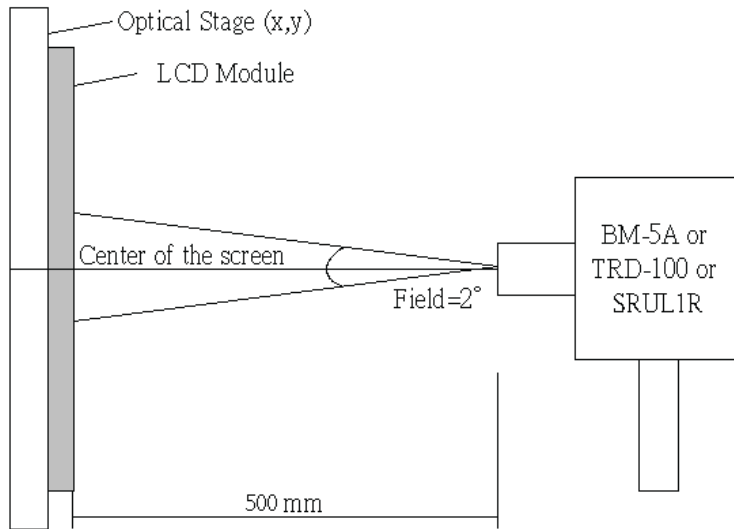

**\*3) Definition of Luminance and Luminance uniformity**

Central luminance: The white luminance is measured at the center position "5" on the screen, see Fig.1 below.

9P Uniformity:  $\Delta L = (L_{min} / L_{max}) \times 100\%$

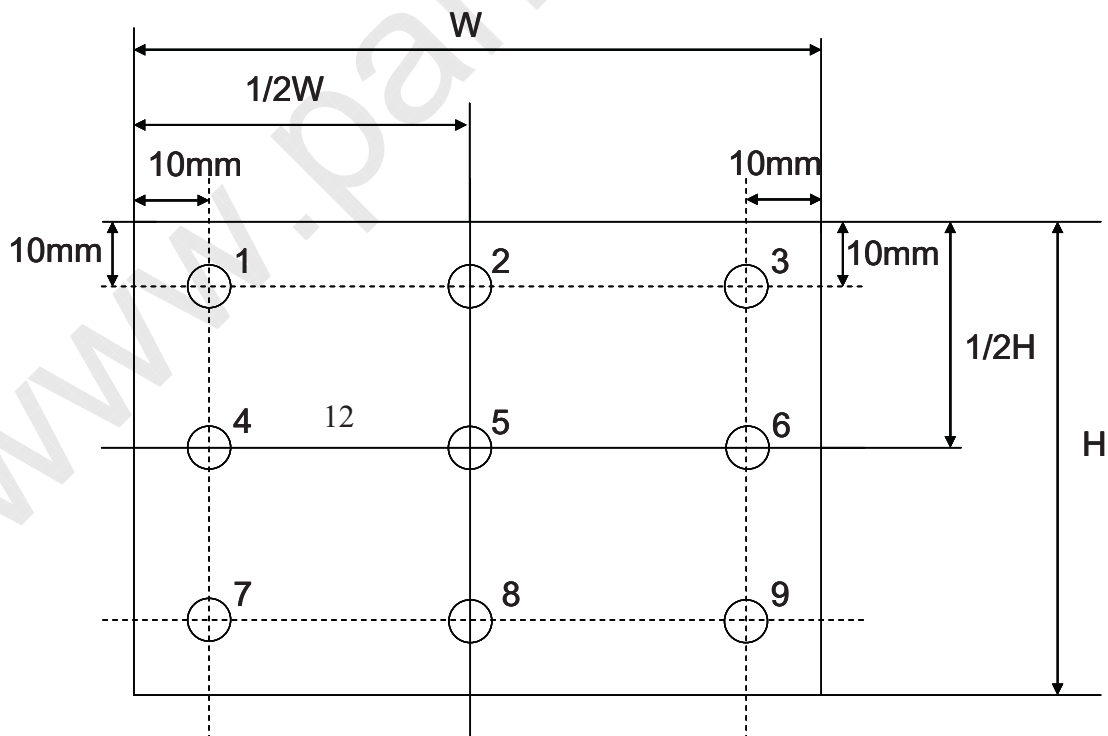

**Fig.1 Measure point (Active Area)**

**Title : CLAA101FP07      Technical Specification**

**\*4) Definition of view angle( $\theta$  ,  $\psi$ )**

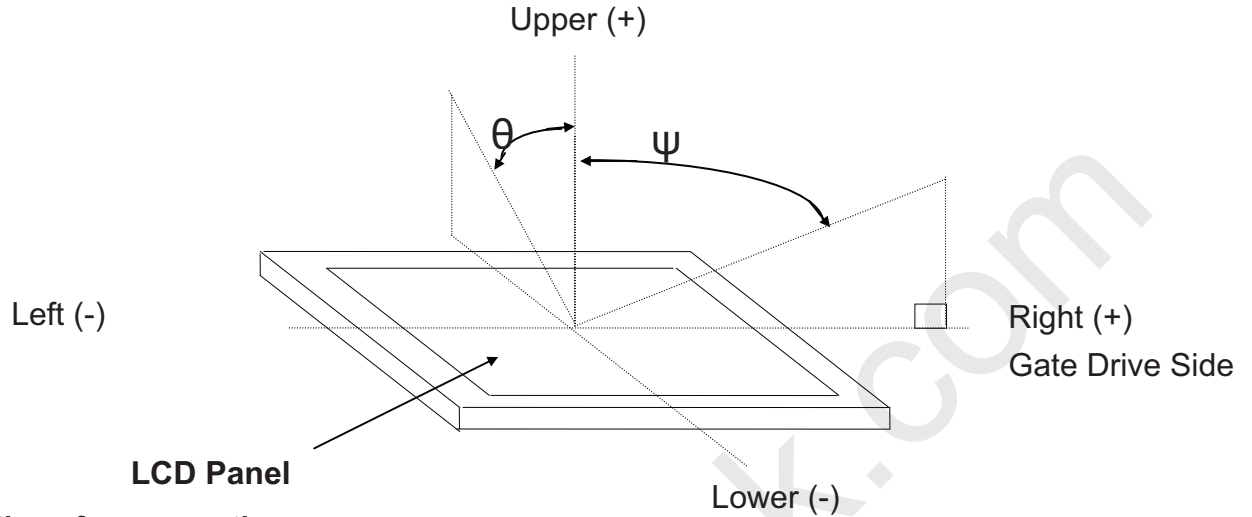

**\*5) Definition of response time**

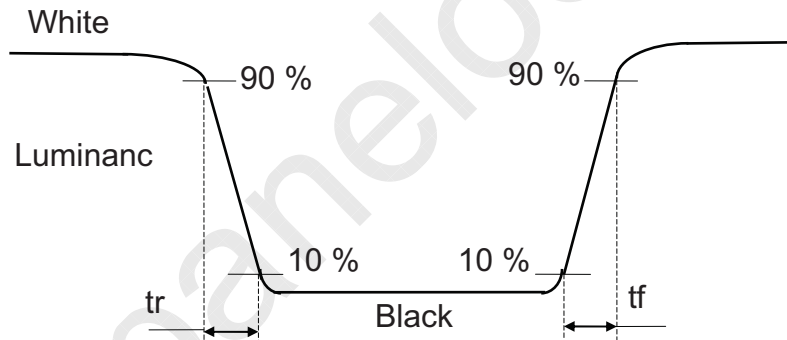

**\*6) Crosstalk Modulation Ratio**

$$CT = | Y_B - Y_A | / Y_{A, \text{max}} \times 100\%$$

$Y_A$  ,  $Y_B$  measure position and definition

$Y_A$  means luminance at gray level 31(exclude gray level 0 pattern)

$Y_B$  means luminance at gray level 31(include gray level 0 pattern)

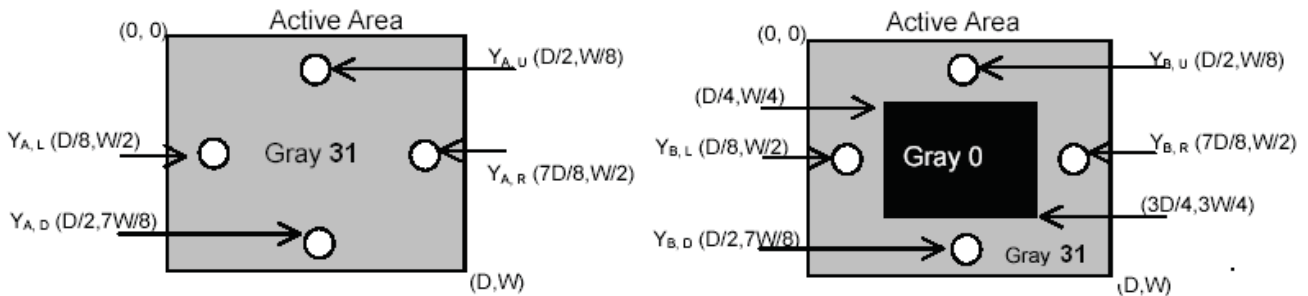

**Title : CLAA101FP07      Technical Specification**

**\*7) Definition of Gamma (VESA)**

Based on Customer Sample, take the average value as a standard center value and the variation range of gamma value caused by loop voltage error should be between +/- 0.2. the bellow figure shows how to obtain the gamma curve and  $\gamma$  (from gray level: 0、4、8-----60、63).

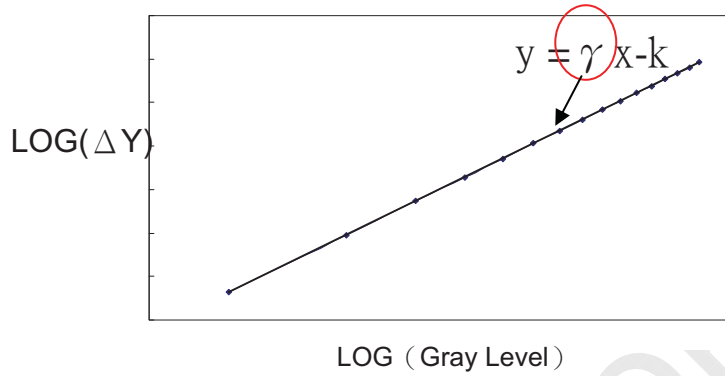

**Title : CLAA101FP07      Technical Specification**

**9. RELIABILITY TEST CONDITIONS**

**(1) Temperature and Humidity**

TEST ITEMS	CONDITIONS
High Temperature Operation	60° C ; 240Hrs
High Temperature Storage	80° C ; 240Hrs
High Temperature High Humidity Operation	40° C ; 90% RH ; 240Hrs
High Temperature High Humidity Storage	60° C ; 90% RH ; 240 Hrs
Low Temperature Operation	-20° C ; 240 Hrs
Low Temperature Storage	-30° C ; 240 Hrs
Thermal Shock	-30° C (0.5 Hr)~70° C (0.5 Hr), Ramp<20° C ,27 CYCLES
Low Air Pressure Test	533mbar(100mbar/min ramp) -40°C~55°C(1°C/min ramp) and 2hrs per each temperature · 24 Hrs

**(2) Shock & Vibration**

TEST ITEMS	CONDITIONS
Shock (Non-Operation)	100G, 6ms, half sin ewave, ± X,± Y,± Z 1time each
Vibration (Non-Operation)	Frequency range: 10-55Hz, stroke:1.5mm, swep time: 1 minute

**(3) ESD**

	Surface discharge(Panel display area · Frame · PWB · Panel back side)		Electrics capacity of Connector
	Contact	Air	Contact
Capacity	150 pF	150 pF	200 pF
Resistance	330 Ω	330 Ω	0 Ω
Voltage	±8kV/±15kV	±8kV/±15kV	±250 V
Interval	1 sec	1 sec	1 sec
Times(single point)	25	25	1

**(4) MTBF without B/L:** 200,000 Hrs (min) lifetimes.

**(5) Judgment standard**

The judgment of the above test should be made as follow:

Pass : Normal display image with no obvious non-uniformity and no line defect.

Partial transformation of the module parts should be ignored.

Fail : No display image, obvious non-uniformity, or line defects.