



Chunghwa Picture Tubes, Ltd.

Technical Specification



To : **Endrich**

Date : 2016/11/28

CPT TFT-LCD

CLAA101FP0H XG

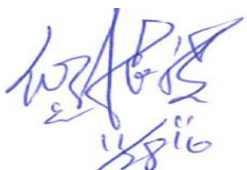
ACCEPTED BY : (V0.1)(Tentative)

APPROVED BY	CHECKED BY	PREPARED BY
 11/28/16	 2016.11.28	 2016.11.28

Prepared by : Design General Division

CHUNGHWA PICTUER TUBES, LTD.

No. 1, Huaying Rd., Sanho Tsun, Lungtan Shiang, Taoyuan, Taiwan, 325, R.O.C.
TEL: +886-3-4805678 FAX: +886-3-2607384

Doc. No:

SPEC_CLAA101FP0H XG_V0.1_Endrich_161128

Issue Date:

2016/11/28

Modification Record List

NO.	Issue Date	Modification Index
1	2016.11.02	First Version
2	2016.11.28	P4. Revised OVERVIEW table P5 Revised ABSOLUTE MAXIMUM RATINGS P9 Revised *1) Maximum LED Driver Input Current P17 Revised Rear side Drawing P18 Revised OPTICAL CHARACTERISTICS table

For Endrich Only/CPT Confidential

Table of Content

NO.	Table of Content	Page
1	OVERVIEW	4
2	ABSOLUTE MAXIMUM RATINGS	5
3	ELECTRICAL CHARACTERISTICS	6
4	CONNECTOR INTERFACE PIN & FUNCTION	11
5	INTERFACE TIMING CHART	12
6	BLOCK DIAGRAM	14
7	MECHANICAL SPECIFICATION	15
8	OPTICAL CHARACTERISTICS	17
9	RELIABILITY TEST CONDITIONS	22
10	WARRANTY	22

For Endrich Only / CPT Confidential

1. OVERVIEW

CLAA101FP0H is 10.1" color (16 : 10) TFT-LCD (Thin Film Transistor Liquid Crystal Display) module composed of LCD panel, driver ICs, control circuit and backlight. By applying 8 bit digital data, 1920×RGB (3) ×1200, 16.7M-color images are displayed on the 10.1" diagonal screen. General specifications are summarized in the following table :

ITEM	SPECIFICATION
Display Area	216.576 (H) x 135.36 (V) (mm) (10.1-inch diagonal)
Number of Pixels	1920×RGB (3) ×1200
Pixel Pitch	0.1128 (H) x 0.1128 (V) (mm)
Color Pixel Arrangement	RGB vertical stripe
Display Mode	HFFS
Number of Colors	16,777,216
Interface Signal	eDP 1.2
Gamut	50% (Typ)
Response Time	30ms (Typ) / 35ms (Max)
Surface Treatment	HC/AG
Viewing Angle	80° · 80° / 80° · 80° (Min) 89° · 89° / 89° · 89° (Typ.)
Brightness	400nits typ/340 nits min
Uniformity	9point : 75%(min)
Consumption of Power	4.28W (Max)
Module Size	229(W)×153 (H)×2.5 (D) (mm) (Typical) (w/o pcb))
Module Weight	150g (Typ.)

The LCD Products listed on this document are not suitable for use of aerospace equipment, submarine cable, and nuclear reactor control system and life support systems. If customers intend to use these LCD products for applications listed above or those not included in the "Standard" list as follows, please contact our sales in advance.

Standard : Computer, Office equipment, Communication equipment, Test and Measurement equipment, Machine tool, Industrial robot, Audio and Visual equipment, Other consumer products.

2. ABSOLUTE MAXIMUM RATINGS

The following are maximum value, which if exceeded, may cause faulty operation or damage to the unit.

ITEM	SYMBOL	MIN	MAX	UNIT	NOTE
LCD Power Voltage	Vin	0	4.0	V	
LED Driver Input Voltage	VBL+	0	16	V	
Operation Temperature	Top	0	60	°C	*1).*2).*3).
Storage Temperature	Tstg	-10	70	°C	*1).*2).*3).

【Note】

- *1) The relative temperature and humidity range are as below sketch, 90%RH Max. ($T_a \leq 40^\circ\text{C}$)
- *2) The maximum wet bulb temperature $\leq 39^\circ\text{C}$ ($T_a > 40^\circ\text{C}$) and without dewing.
- *3) If product in environment which over the definition of the relative temperature and humidity out of range too long, it will affect visual of LCD.

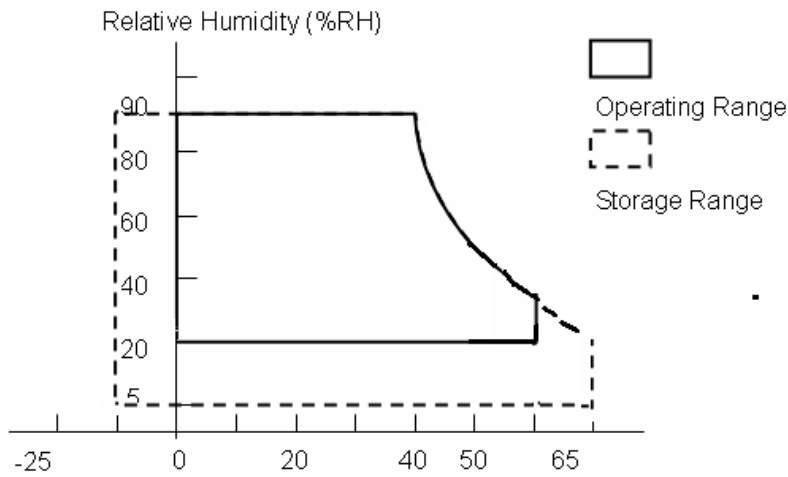

3. ELECTRICAL CHARACTERISTICS

(A) TFT LCD

ITEM	SYMBOL	MIN	TYP	MAX	UNIT	NOTE
LCD Power Voltage	Vin	3.0	3.3	3.6	V	*1)
LCD Power Current	Iin	-	-	TBD	mA	*2)
Rush Current	Irush	-	-	3	A	*3)

【Note】

*1) Power Sequence :

$0.01 \text{ ms} < t1 \leq 50 \text{ ms}$

$500 \text{ ms} \leq t4$

$100 \text{ ms} \leq t2 \leq 150 \text{ ms}$

$200 \text{ ms} \leq t5$

$0.01 \text{ ms} < t3 \leq 50 \text{ ms}$

$200 \text{ ms} \leq t6$

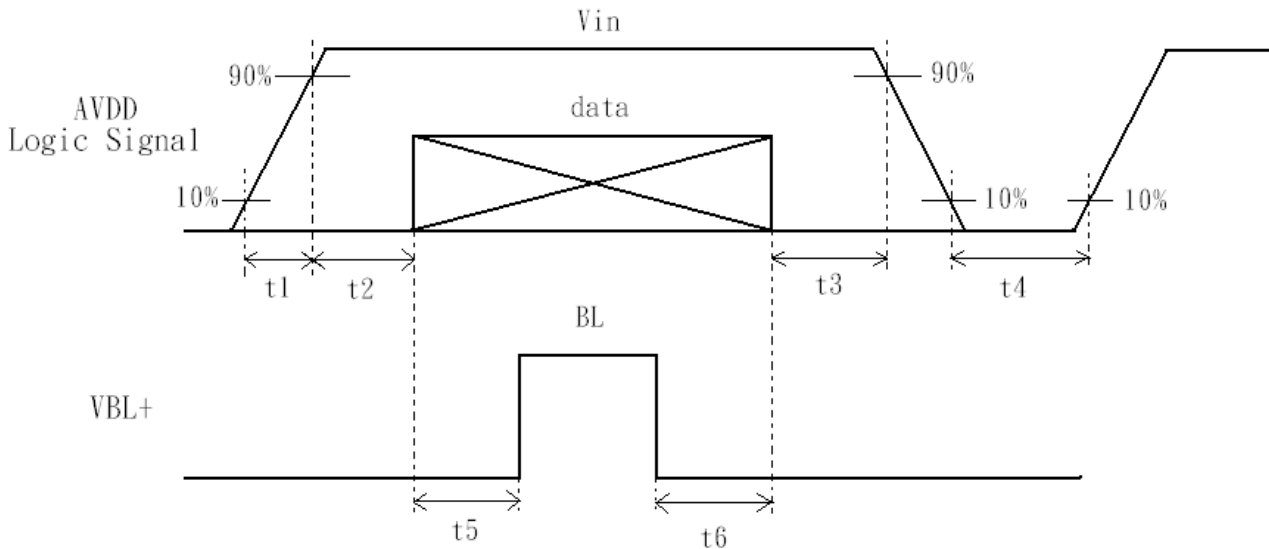

data:RGB DATA, DCLK, HD, VD, DENA

Vin-dip state

(1) when $3.0V > Vin \geq 2.7V$, $td \leq 10 \text{ ms}$.

(2) when $Vin < 2.7V$, Vin-dip condition should as the Vin-turn-off condition.

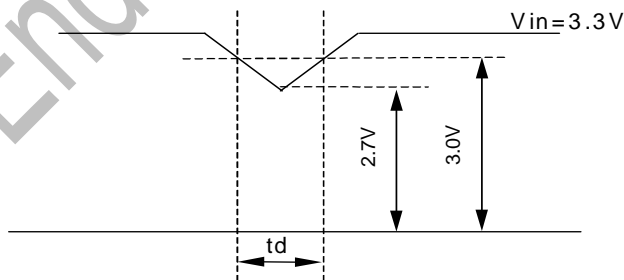

*2) Max value is White Pattern : 1200 line mode.

Circuit condition (Max) : $V_{CC}=3.3\text{ V}$, $f_V=60\text{ Hz}$, $f_H=74.1\text{ kHz}$, $f_{CLK}=154\text{ MHz}$.

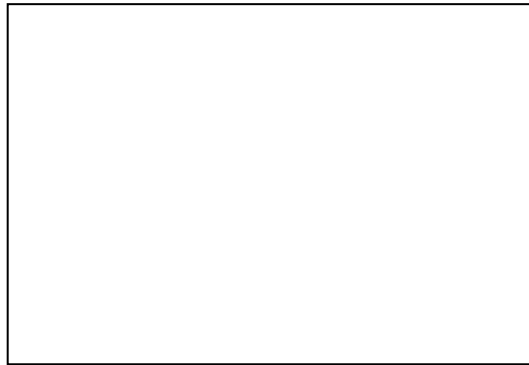

*4) Irush measure condition

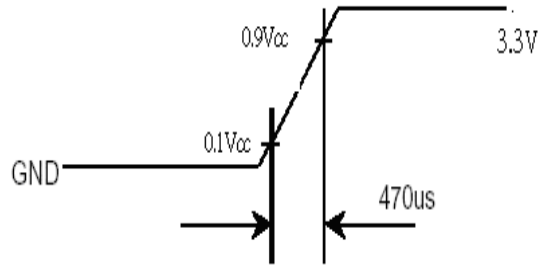
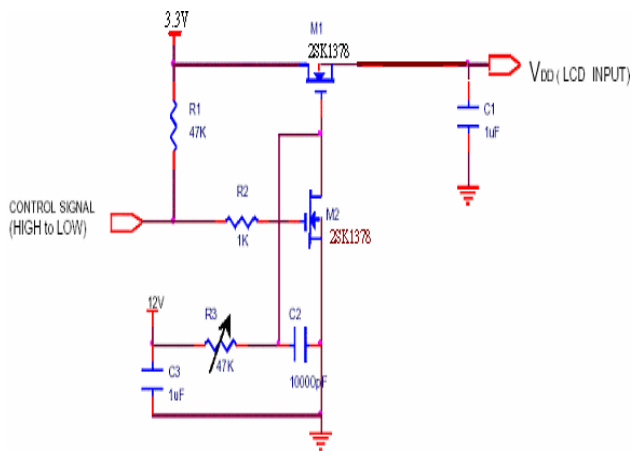

For Endrich On...

(B) BACK LIGHT

(a.) ELECTRICAL CHARACTERISTICS

Ta=25°C

ITEM	SYMBOL	MIN	TYP	MAX	UNIT	NOTE
LED Driver Input Voltage	VBL+	7.0	12	16	V	
LED Driver Input Current	IBL+	-		TBD	mA	*1)
Forward Voltage	V _F	2.7	2.8	3.0	V	*2) I _F =20mA
Forward Current	I _F	-	(20)	-	mA	*2) I _F =20mA
Power Consumption	PLED			(2.52)	W	*2)*3) I _F =20mA
PWM Frequency	PWM_BL	100	-	1000	Hz	
Duty ratio	Dim	10	-	100	%	

(b.) LED LIFE – TIME

ITEM	CONDITION	MIN	TYP	MAX	UNIT	NOTE
Life Time	I _F =20mA · Ta=25°C	15000			hrs	*4)

(c.) LED ON/OFF Sequence :

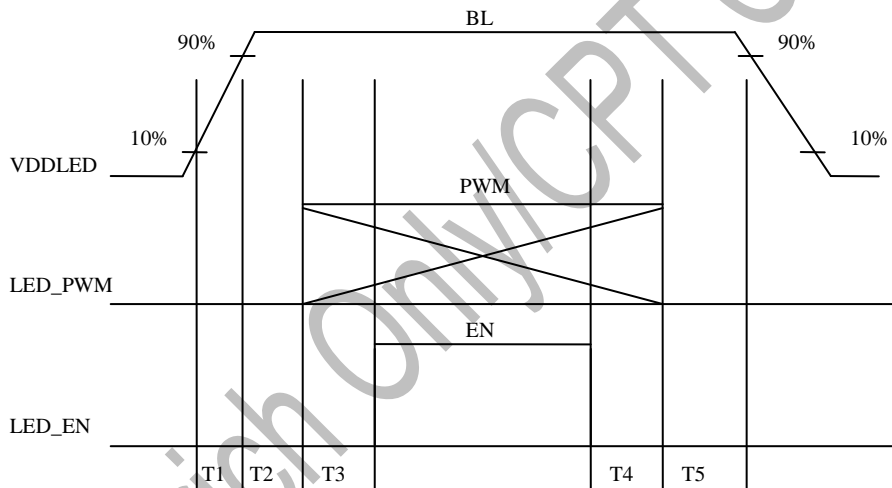

$0.5ms \leq T1 \leq 10ms$

$10ms \leq T2$

$10ms \leq T3$

$0ms \leq T4$

$10ms \leq T5$

Note:

The LED power variation spec. is defined as the following figure.

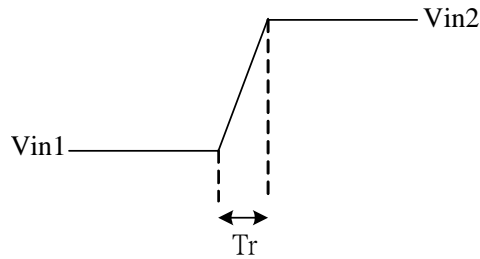

When LED input voltage is from Vin1 up to Vin2, the slew rate should be less than 20 V/ms.

$$\text{Slew rate} = (\text{Vin2} - \text{Vin1}) / \text{Tr} \quad , \quad \text{Vin2} > \text{Vin1}$$

- *1) Maximum LED Driver Input Current at 7V Input Voltage/PWM Duty 100%.
- *2) Measure method : a. LED current is measured by utilizing a current meter as show below.
 b. System power PLED is measured at input voltage 12V.

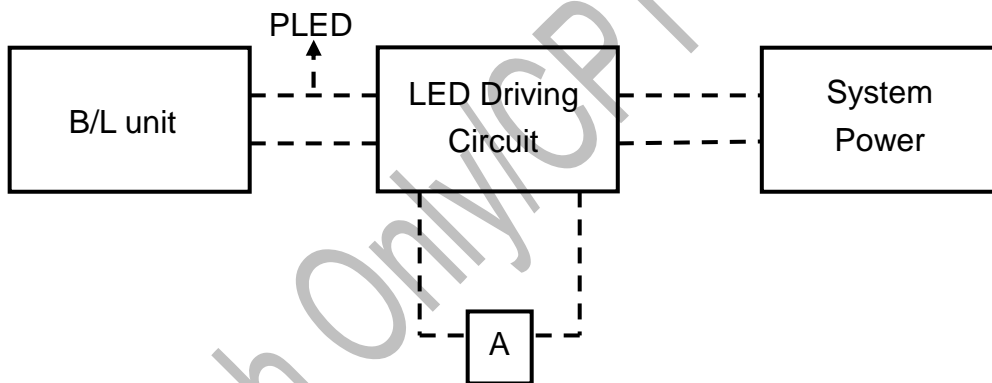

- *3) Calculator value for reference $I_F \times V_F \times N = \text{PLED}$
 $\text{PLED} = I_F \times V_F \times N = 20 \times 3.0 \times 42 = 2.52 \text{ W} . (\text{Without LED Driver})$
 Consumption of Power with 80% LED efficiency

- *4) Life time means that estimated time to 50% degradation of initial luminous intensity.

4. Connector Interface PIN & Function

CN (Interface signal)

Outlet connector: 20455-030E-12 (I-PEX)

- Pin No. is 30 pin define of Plug connector

PIN NO	SYMBOL	DESCRIPTION
1	NC	Reserved
2	H_GND	High Speed Ground
3	LAN1_N	Complement Signal Link Lane 1
4	LAN1_P	True Signal Link Lane 1
5	H_GND	High Speed Ground
6	LAN0_N	Complement Signal Link Lane 0
7	LAN0_P	True Signal Link Lane 0
8	H_GND	High Speed Ground
9	AUX_P	True Signal Auxiliary Ch.
10	AUX_N	Complement Signal Auxiliary Ch.
11	H_GND	High Speed Ground
12	VCC	LCD logic and driver power(Power Supply,3.3V typocal)
13	VCC	LCD logic and driver power(Power Supply,3.3V typocal)
14	NC	Reserved (BIST function)
15	LCD_GND	LCD logic and driver ground
16	NC	Reserved
17	HPD	HPD signal pin
18	BL_GND	Backlight ground
19	BL_GND	Backlight ground
20	BL_GND	Backlight ground
21	BL_GND	Backlight ground
22	BL_ENABLE	Backlight On/Off enable pin(+3.3V Input)
23	BL_PWM_DIM	System PWM signal input for dimming(+3.3V Swing)
24	SDA	Reserved(For EDID SDA)
25	SCL	Reserved(For EDID SCL)
26	BL_PWR	Backlight power (7V - 16V LED power)
27	BL_PWR	Backlight power (7V - 16V LED power)
28	BL_PWR	Backlight power (7V - 16V LED power)
29	BL_PWR	Backlight power (7V - 16V LED power)
30	LCD_GND	LCD logic and driver ground

5. INTERFACE TIMING CHART

5.1 Timing sequence(Timing chart)

(1) eDP input time sequence and signal definite :

The VESA Display Port related AC specification is compliant with the specification in the VESA Display Port Standard v1.2a.

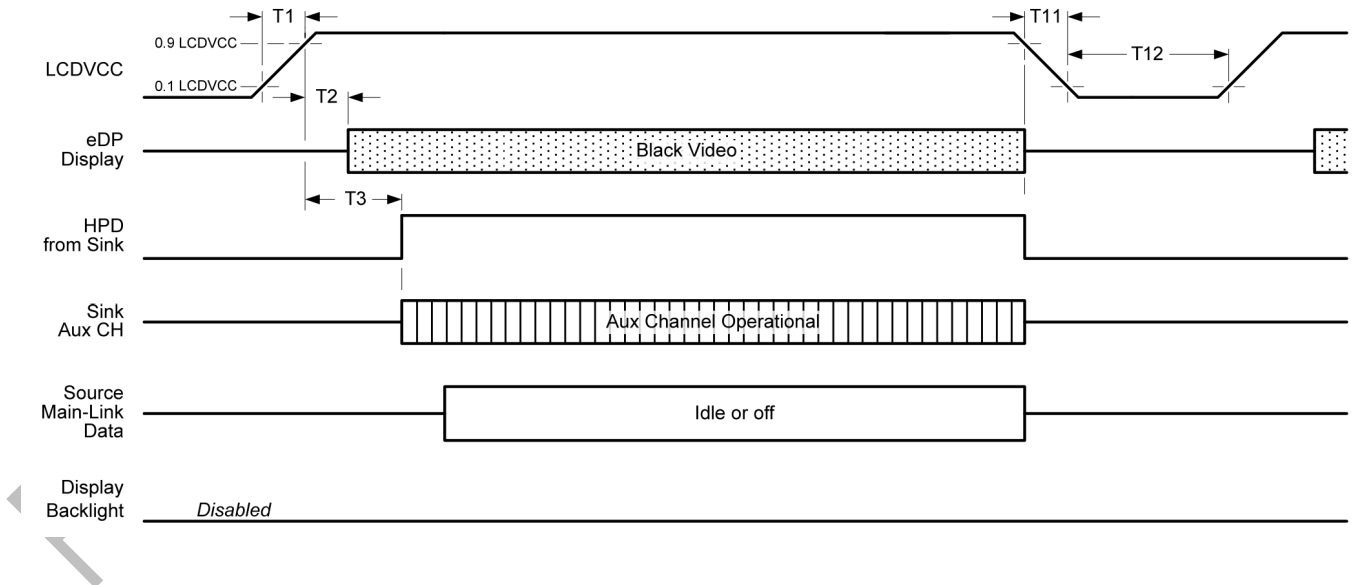
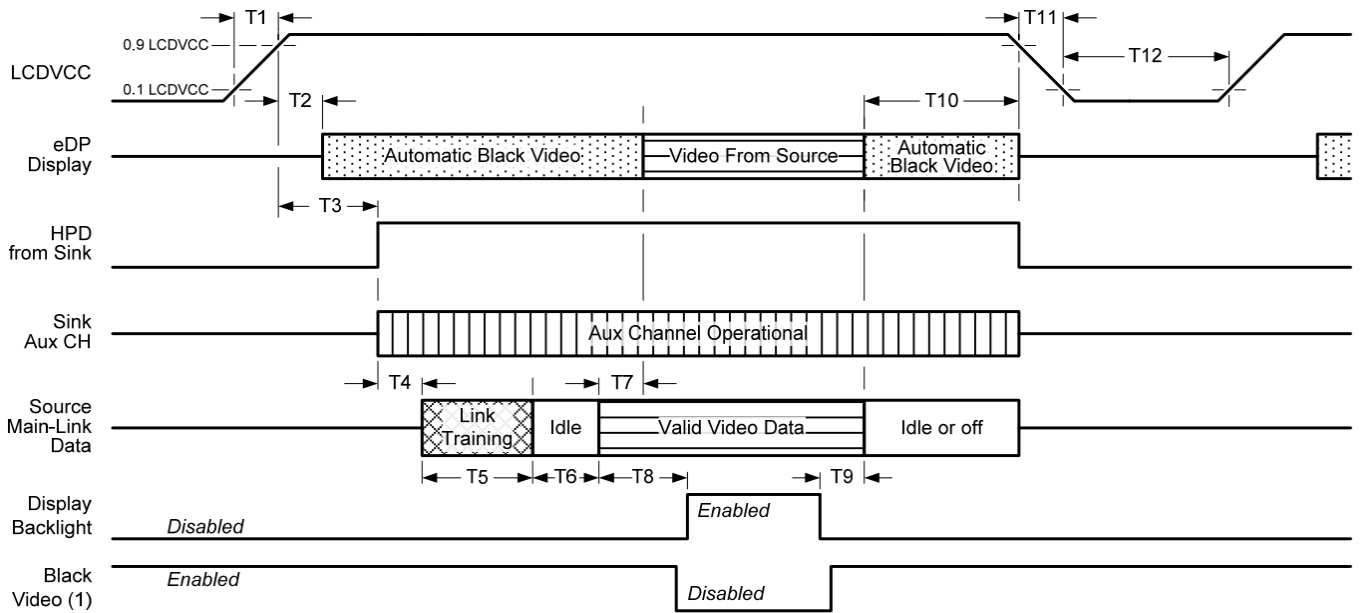

Timing Parameter	Description	Required By	Limits		Notes
			Min	Max	
T1	Power rail rise time, 10% to 90%	Source	0.5ms	10ms	
T2	Delay from LCDVCC to automatic black video generation	Sink	0ms	200ms	Automatic black video generation prevents display noise until valid video data is received from the Source (see note 1 below)
T3	Delay from LCDVCC to HPD high	Sink	0ms	200ms	Sink AUX Channel must be operational upon HPD high
T4	Delay from HPD high to link training initialization	Source	-	-	Allows for Source to read Link capability and initialize
T5	Link training duration	Source	-	-	Dependant on Source link training protocol
T6	Link idle	Source	-	-	Min accounts for required BS-Idle pattern. Max allows for Source frame synchronization.
T7	Delay from valid video data from Source to video on display	Sink	0ms	50ms	Max value allows for Sink to validate video data and timing. At the end of T7, Sink will indicate the detection of valid video data by setting the SINK_STATUS bit to logic 1 (DPCD 00205h, bit 0), and Sink will no longer generate automatic black video.
T8	Delay from valid video data from Source to backlight enable	Source	-	-	Source must assure display video is stable
T9	Delay from backlight disable to end of valid video data	Source	-	-	Source must assure backlight is no longer illuminated (see note 1 below). At the end of T9, Sink will indicate the detection of no valid video data by setting the SINK_STATUS bit to logic 0 (DPCD 00205h, bit 0), and Sink will automatically display black video.
T10	Delay from end of valid video data from Source to power off	Source	0ms	500ms	
T11	Power rail fall time, 90% to 10%	Source	-	10ms	
T12	Power off time	Source	500ms	-	

5.2 DATA mapping

COLOR	INPUT DATA	R DATA								G DATA								B DATA							
		R7	R6	R5	R4	R3	R2	R1	R0	G7	G6	G5	G4	G3	G2	G1	G0	B7	B6	B5	B4	B3	B2	B1	B0
		MSB							LSB	MSB							LSB	MSB							LSB
BASIC COLOR	BLACK	0	0	0	0	0	0	0	0	0	0	0	0	0	0	0	0	0	0	0	0	0	0	0	0
	RED(255)	1	1	1	1	1	1	1	1	0	0	0	0	0	0	0	0	0	0	0	0	0	0	0	
	GREEN(255)	0	0	0	0	0	0	0	0	1	1	1	1	1	1	1	0	0	0	0	0	0	0	0	
	BLUE(255)	0	0	0	0	0	0	0	0	0	0	0	0	0	0	0	1	1	1	1	1	1	1	1	
	CYAN	0	0	0	0	0	0	0	0	1	1	1	1	1	1	1	1	1	1	1	1	1	1	1	
	MAGENTA	1	1	1	1	1	1	1	1	0	0	0	0	0	0	0	1	1	1	1	1	1	1	1	
	YELLOW	1	1	1	1	1	1	1	1	1	1	1	1	1	1	1	0	0	0	0	0	0	0	0	
	WHITE	1	1	1	1	1	1	1	1	1	1	1	1	1	1	1	1	1	1	1	1	1	1	1	
RED	RED(0)	0	0	0	0	0	0	0	0	0	0	0	0	0	0	0	0	0	0	0	0	0	0	0	
	RED(1)	0	0	0	0	0	0	0	1	0	0	0	0	0	0	0	0	0	0	0	0	0	0	0	
	RED(2)	0	0	0	0	0	0	1	0	0	0	0	0	0	0	0	0	0	0	0	0	0	0	0	
	RED(254)	1	1	1	1	1	1	1	0	0	0	0	0	0	0	0	0	0	0	0	0	0	0	0	
	RED(255)	1	1	1	1	1	1	1	1	0	0	0	0	0	0	0	0	0	0	0	0	0	0	0	
GREEN	GREEN(0)	0	0	0	0	0	0	0	0	0	0	0	0	0	0	0	0	0	0	0	0	0	0	0	
	GREEN(1)	0	0	0	0	0	0	0	0	0	0	0	0	0	0	1	0	0	0	0	0	0	0	0	
	GREEN(2)	0	0	0	0	0	0	0	0	0	0	0	0	0	1	0	0	0	0	0	0	0	0	0	
	GREEN(254)	0	0	0	0	0	0	0	0	1	1	1	1	1	1	0	0	0	0	0	0	0	0	0	
	GREEN(255)	0	0	0	0	0	0	0	0	1	1	1	1	1	1	1	0	0	0	0	0	0	0	0	
BLUE	BLUE(0)	0	0	0	0	0	0	0	0	0	0	0	0	0	0	0	0	0	0	0	0	0	0	0	
	BLUE(1)	0	0	0	0	0	0	0	0	0	0	0	0	0	0	0	0	0	0	0	0	0	0	1	
	BLUE(2)	0	0	0	0	0	0	0	0	0	0	0	0	0	0	0	0	0	0	0	0	0	1	0	
	BLUE(254)	0	0	0	0	0	0	1	0	0	0	0	0	0	0	0	1	1	1	1	1	1	1	0	
	BLUE(255)	0	0	0	0	0	0	0	0	0	0	0	0	0	0	0	1	1	1	1	1	1	1	1	

【Note】

- 1) Gray level:
Color(n) : n is level order; higher n means brighter level.
- 2) DATA:
1: high , 0: low

5.3 Timing Chart

ITEM		SYMBOL	MIN	TYP	MAX	UNIT		
LCD Timing	Frame Rate		-	60	60	60	Hz	
	DCLK	Frequency	f_{CLK}	-	154	-	MHz	
		Period	t_{CLK}	-	6.5	-	ns	
	DENA	Horizontal	Horizontal total time	t_H	-	2080	-	t_{CLK}
			Horizontal Active time	t_{HA}	1920	1920	1920	t_{CLK}
			Horizontal Blank time	t_{HB}	-	160	-	t_{CLK}
		Vertical	Vertical total time	t_V	-	1235	-	t_H
			Vertical Active time	t_{VA}	1200	1200	1200	t_H
			Vertical Blank time	t_{VB}	-	35	-	t_H

【Note】

- *1) DENA (DATA ENABLE) usually is positive.
- *2) During the whole blank period, DCLK should keep input.

6. BLOCK DIAGRAM

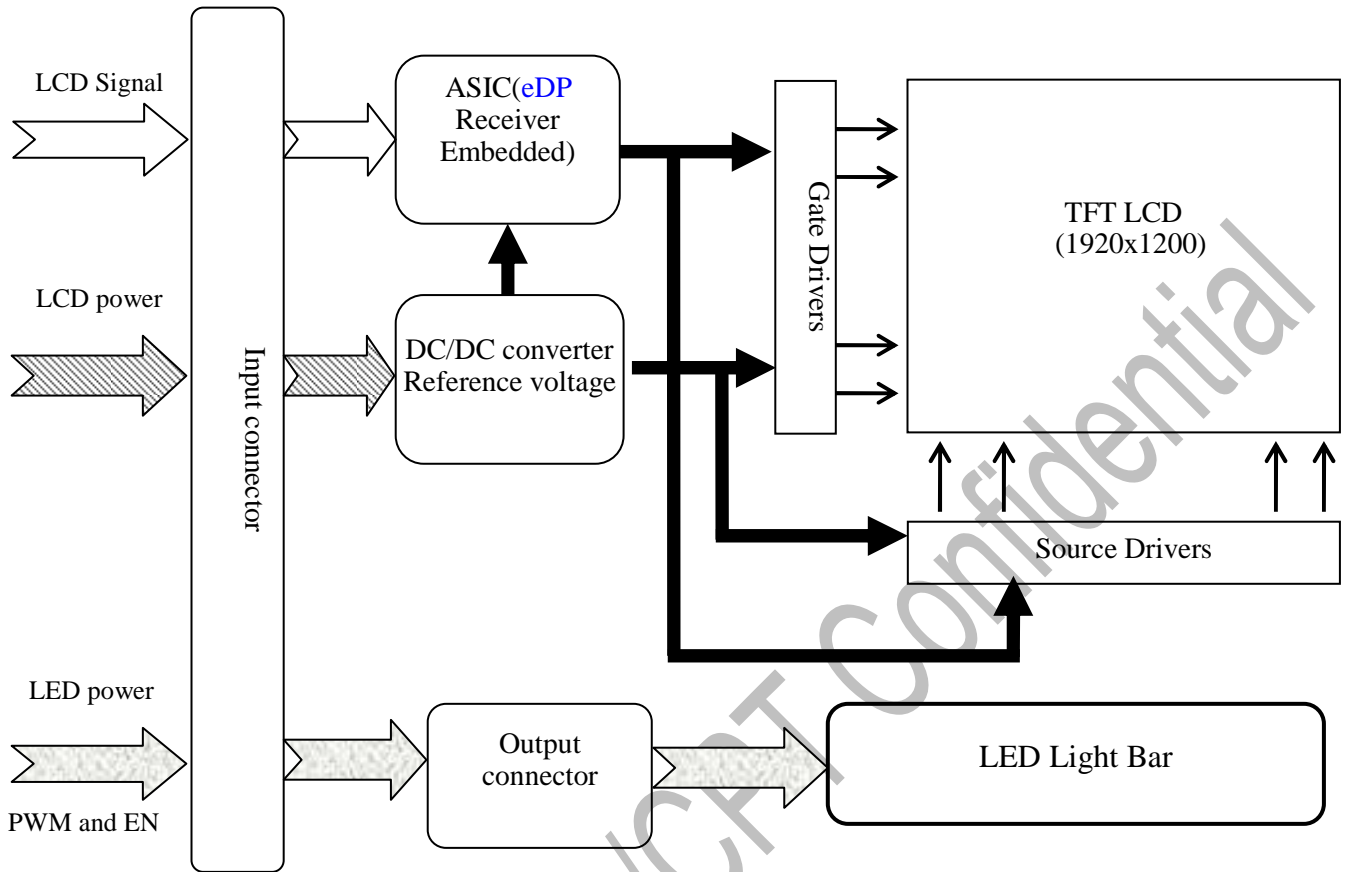

7. MECHANICAL SPECIFICATION

(1) Front side

The tolerance, not show in the figure, is ± 0.5 mm.

[Unit : mm]

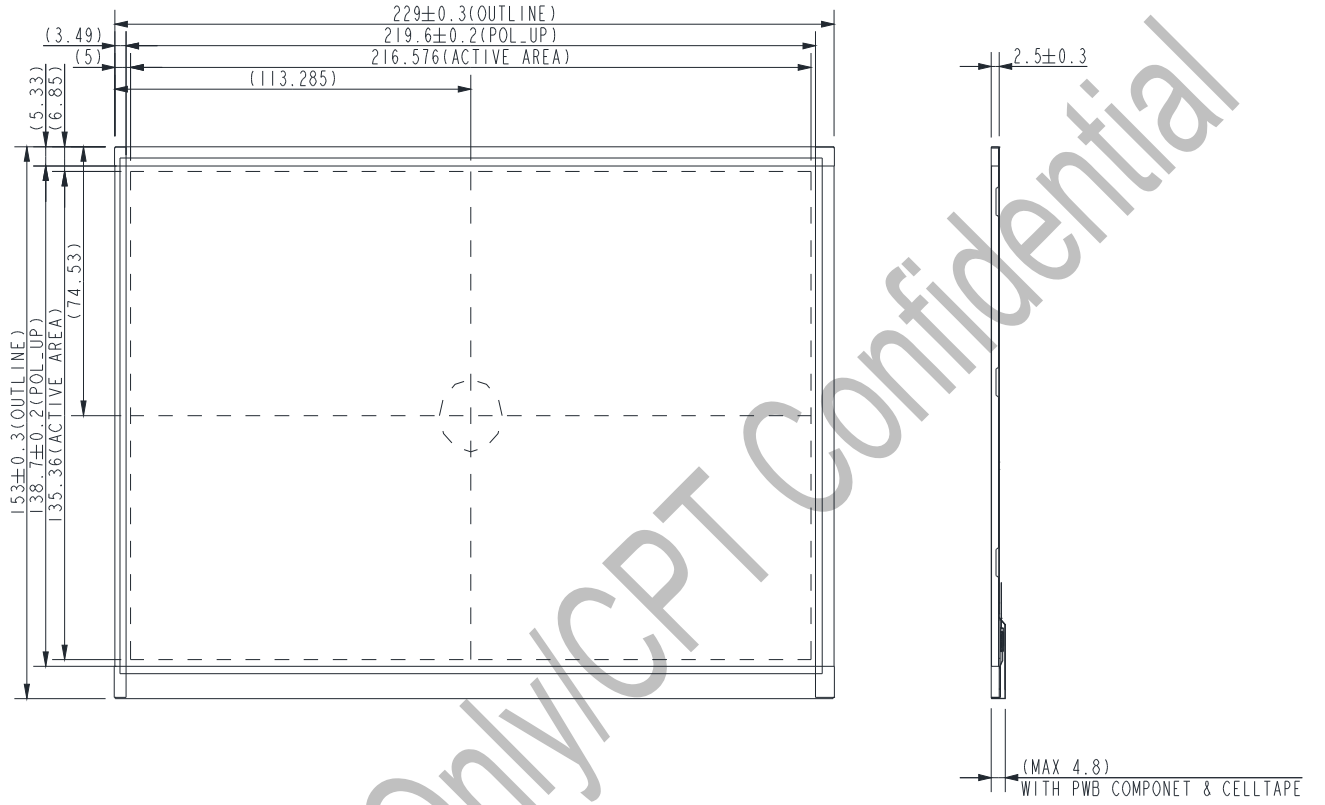

For Endrich Only/CPT Confidential

(2) Rear side

The tolerance, not show in the figure, is ± 0.5 mm.

[Unit : mm]

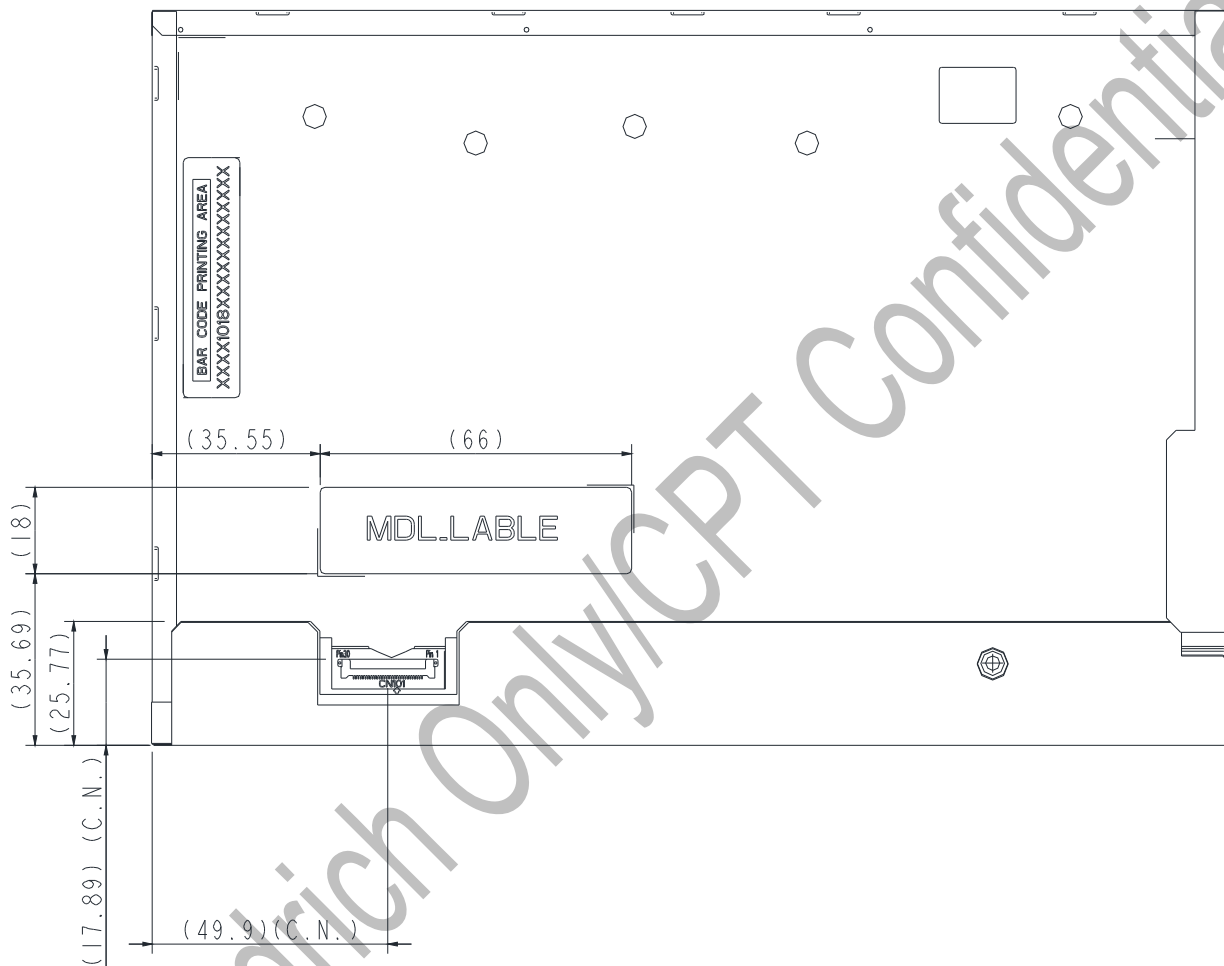

8. OPTICAL CHARACTERISTICS

$T_a=25^{\circ}\text{C}\pm 2^{\circ}\text{C}$, $60\pm 10\%\text{RH}$, $V_{DD}=3.3\text{V}$

ITEM	SYMBOL	CONDITION	MIN	TYP	MAX	UNIT	NOTE	
Contrast Ratio	CR	$\theta = \psi = 0^{\circ}$	600	750	--	--	*1) 2)	
Luminance (center)	L	$\theta = \psi = 0^{\circ}$	340	400	--	cd/m ²	*1) 3)	
Uniformity(9P)	ΔL	$\theta = \psi = 0^{\circ}$	75	--	--	%	*1) 3)	
Response Time	Tr	$\theta = \psi = 0^{\circ}$	--	30	35	ms	*5)	
	Tf							
Cross Talk	CT	$\theta = \psi = 0^{\circ}$	--	--	1.0	%	*6)	
View Angle	Horizontal	ψ	$CR \geq 10$	80/-80	89/-89	--	°	*4)
	Vertical	θ		80/-80	89/-89	--	°	*4)
Color Coordinate	W	x	$\theta = \psi = 0^{\circ}$	0.281	0.311	0.341	*3)	
		y		0.327	0.357	0.387		
	R	x		(0.562)	(0.602)	(0.642)		
		y		(0.308)	(0.348)	(0.388)		
	G	x		(0.282)	(0.322)	(0.362)		
		y		(0.506)	(0.546)	(0.586)		
B	x	(0.113)	(0.153)	(0.193)				
	y	(0.089)	(0.129)	(0.169)				
Gamut		$\theta = \psi = 0^{\circ}$	45	50	--	%		
Gamma	γ	GL	2.0	2.2	2.4		*7)	

Color coordinate and color gamut are measured by SRUL1R, response time is measured by TRD-100, and all the other items are measured by BM-5A (TOPCON). All these items are measured under the dark room condition (no ambient light).

Measurement Condition: IL= 20mA (each LED)

Definition of these measurement items is as follows:

*1) Setup of Measurement Equipment

The LCD module should be turn-on to a stable luminance level to be reached. The measurement should be executed after lighting Backlight for **10** minutes and in a dark room.

***2) Definition of Contrast Ratio**

CR=ON (White) Luminance/OFF (Black) Luminance

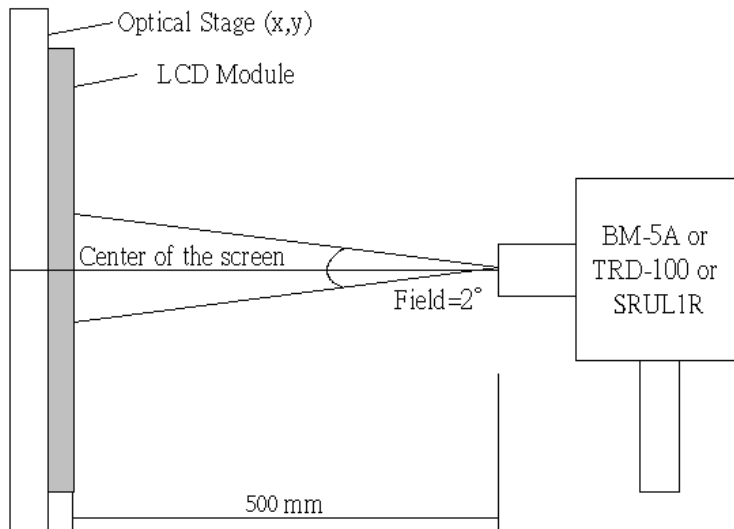

***3) Definition of Luminance and Luminance uniformity**

Central luminance: The white luminance is measured at the center position "5" on the screen, see Fig below.

9P Uniformity: $\Delta L = (L_{min} / L_{max}) \times 100\%$

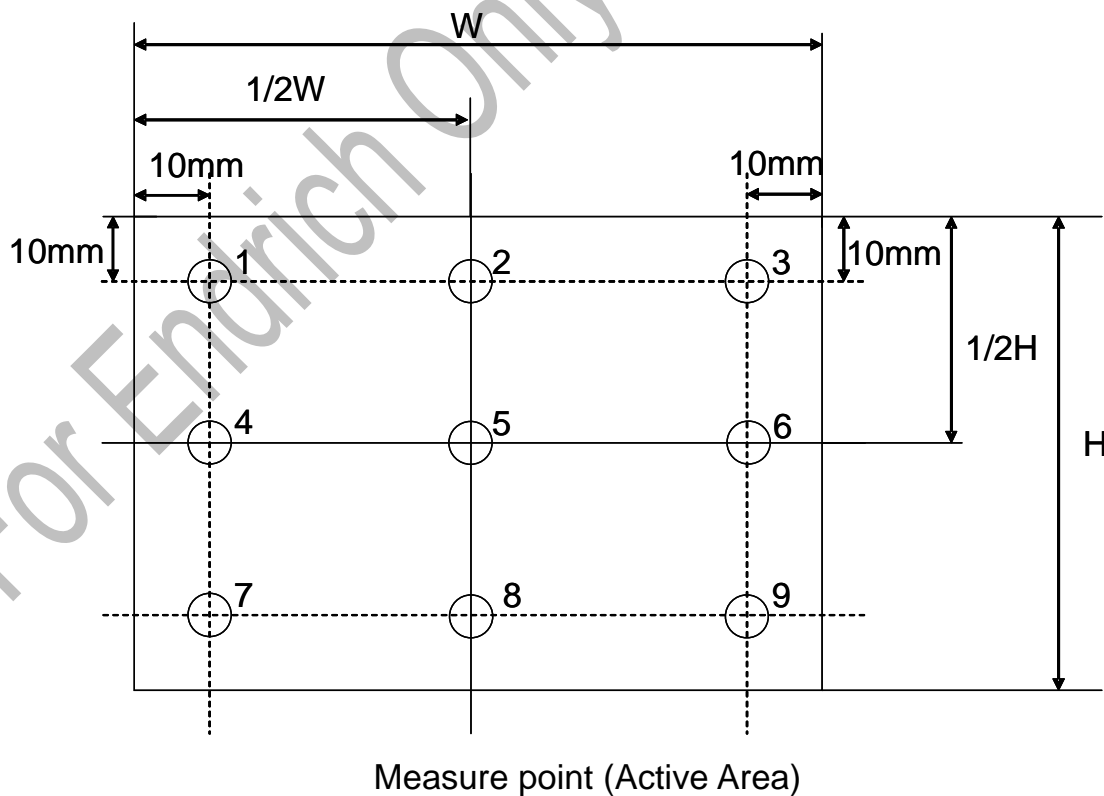

***4) Definition of view angle(θ , ψ)**

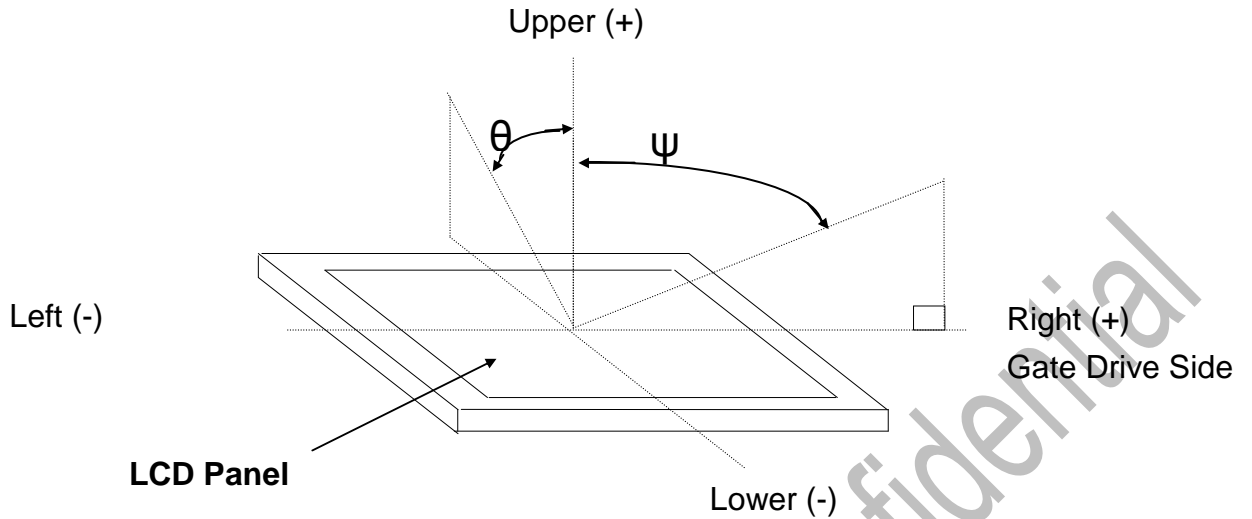

***5) Definition of response time**

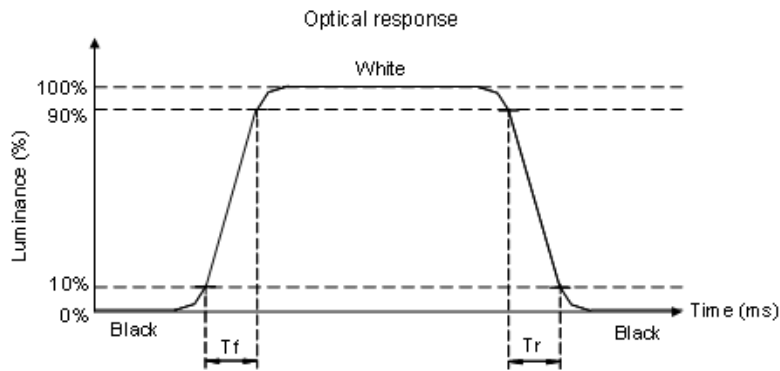

***6) Crosstalk Modulation Ratio**

$$CT = | Y_B - Y_A | / Y_{Ax} \times 100\%$$

Y_A , Y_B measure position and definition

Y_A means luminance at gray level 128(exclude gray level 255 pattern)

Y_B means luminance at gray level 128(include gray level 255 pattern)

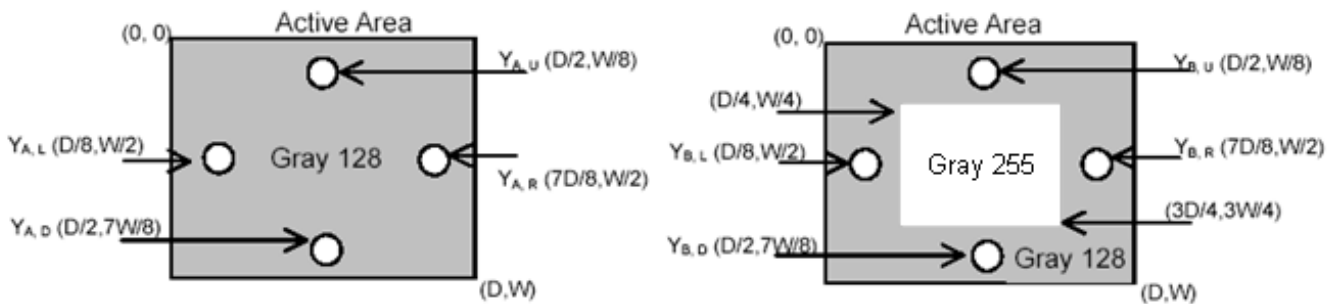

***7) Definition of Gamma (VESA)**

Based on Customer Sample, take the average value as a standard center value and the variation range of gamma value caused by loop voltage error should be between +/- 0.2. the bellow figure shows how to obtain the gamma curve and γ (from gray level: 0、15、31-----239、255).

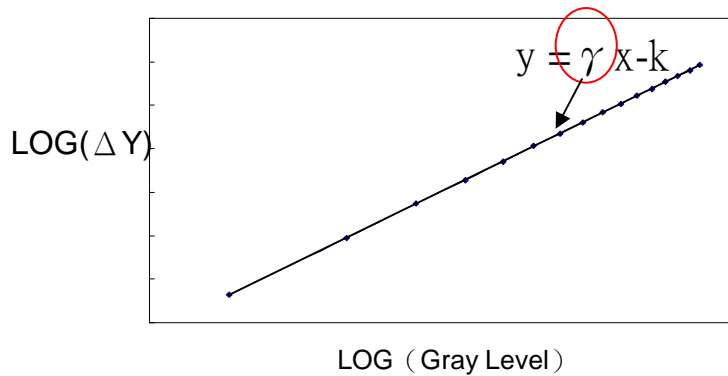

For Endrich Only/CPT Confidential

9. RELIABILITY TEST CONDITIONS

(1) Temperature and Humidity

TEST ITEMS	CONDITIONS
High Temperature Operation	60°C ; 240Hrs
High Temperature Storage	70°C ; 240Hrs
High Temperature High Humidity Operation	40° C ; 90% RH ; 240Hrs
Low Temperature Operation	0°C ; 240 Hrs
Low Temperature Storage	-10°C ; 240 Hrs
Thermal Shock	-10° C (0.5 Hr)~70° C (0.5 Hr), Ramp<20° C ,56 CYCLES

(2) Shock & Vibration

TEST ITEMS	CONDITIONS
Shock (Non-Operation)	100G 6ms,±X, ±Y, ±Z 1 times for each direction (Total is 6 times)
Vibration (Non-Operation)	Frequency : 8~33.3Hz Stoke : 1.3 mm Vibration : sin wave, per axis (both X,Z axis: 2hrs ,Y axis: 4hrs) Sweep : 2.9G, 33.3 Hz -400 Hz Cycle time: 15 min.

(3) ESD

TEST ITEMS	CONDITIONS
Connector Contact	200 pF, 0 Ω(±200 V, once for each terminal)
Air	150 pF, 330 Ω , ±10 KV, 5 times/point, 9 points/panel
Contact	150 pF, 330 Ω , ±6 KV, 5 times/point, 9 points/panel

(4) Judgment standard

The judgment of the above test should be made as follow:

Pass: Normal display image with no line defect.

Fail: No display image, function NG, or line defects.

10. WARRANTY

- (1). The period is within 12 months since the date of shipping out under normal using and storage conditions.
- (2). The warranty will be avoided in case of defect induced by customer.