



Chunghwa Picture Tubes, Ltd.

Technical Specification

To : Studio Technology Co.,Ltd

Date : 2009/08/17

CPT TFT-LCD
CLAA101NB03

Accepted by:
(Tentative version)

APPROVED BY	CHECKED BY	PREPARED BY
Ronald Huang	Roger Liu	Carol Shen

Prepared by :

Product Planning Management Division
Small & Medium TFT Product Business Unit

CHUNGHWA PICTURE TUBES, LTD.

No. 1, Huaying Rd., Sanho Tsun, Lungtan Shiang, Taoyuan, Taiwan, 325, R.O.C.
TEL: +886-3-3675151 FAX: +886-3-377-3003

Doc. No:	CLAA101NB03-HAOSHENG-T1-20090817	Issue Date:	20090817
----------	----------------------------------	-------------	----------

Modification Record List

NO.	Issue Date	Modification Index
1	2009/06/23	The tentativeversion

Studio Technology Co., Ltd

Table Of Content

NO.	Table of Content	Page
1	OVERVIEW	3
2	ABSOLUTE MAXIMUM RATINGS	4
3	ELECTRICAL CHARACTERISTICS	5
4	CONNECTOR INTERFACE PIN & FUNCTION	9
5	INTERFACE TIMING CHART	10
6	BLOCK DIAGRAM	12
7	MECHANICAL SPECIFICATION	13
8	OPTICAL CHARACTERISTICS	15
9	RELIABILITY TEST CONDITIONS	18

Studio Technology Co., Ltd.

1. OVERVIEW

CLAA101NB03 is 10.1" color TFT-LCD (Thin Film Transistor Liquid Crystal Display) module composed of LCD panel, LVDS driver ICs, control circuit and backlight. By applying 6 bit digital data, 1024×RGB (3) ×600, 262K-color images are displayed on the 10.1" diagonal screen. general specifications are summarized in the following table :

ITEM	SPECIFICATION
Display Area (mm)	222.72 (H)×125.28 (V) (10.1-inch diagonal)
Number of Pixels	1024 ×3(H)×600 (V)
Pixel Pitch (mm)	0.2175 (H)×0.2088(V)
Color Pixel Arrangement	RGB vertical stripe
Display Mode	Normally white
Number of Colors	262,144(6bits)(LVDS)
Gamut	42%(Min)/45%(Typ)
Optimum Viewing Angle	6 o'clock
Response Time (ms)	8ms (Typ)/16ms (Max)
Surface Treatment	Anti-Glare type , Hardness : 3H
Viewing Angle	45°、45°/15°、35°(Typ)
Brightness (cd/m ²)	200 cd/m ² (5point)/20 mA (Typ) 180 cd/m ² (5point)/20 mA (Min)
Uniformity	5point : 80 %(Min) 13point : 65 %(Min)
Consumption of Power (W)	2.8W (Max)
Module Size (mm)	243(W)×146.5(H)×3.6(D) (Max)
Module Weight (g)	170 (Max)

The LCD Products listed on this document are not suitable for use of aerospace equipment, submarine cable, and nuclear reactor control system and life support systems. If customers intend to use these LCD products for applications listed above or those not included in the "Standard" list as follows, please contact our sales in advance.

Standard : Computer, Office equipment, Communication equipment, Test and Measurement equipment, Machine tool, Industrial robot, Audio and Visual equipment, Other consumer products.

2. ABSOLUTE MAXIMUM RATINGS

The following are maximum value, which if exceeded, may cause faulty operation or damage to the unit.

ITEM	SYMBOL	MIN.	MAX.	UNIT	NOTE
Power Supply Voltage for LCD	VCC	0	4.0	V	
Operation Temperature	Top	0	50	°C	*1). 2). 3). 4)
Storage Temperature	Tstg	-25	65	°C	*1). 2). 3)

【Note】

- *1) The relative temperature and humidity range are as below sketch, 90%RH Max. ($T_a \leq 40^\circ\text{C}$)
- *2) The maximum wet bulb temperature $\leq 39^\circ\text{C}$ ($T_a > 40^\circ\text{C}$) and without dewing.
- *3) If product in environment which over the definition of the relative temperature and humidity out of range too long, it will affect visual of LCD.
- *4) If you operate LCD in normal temperature range, the center surface of panel should be under 50°C .

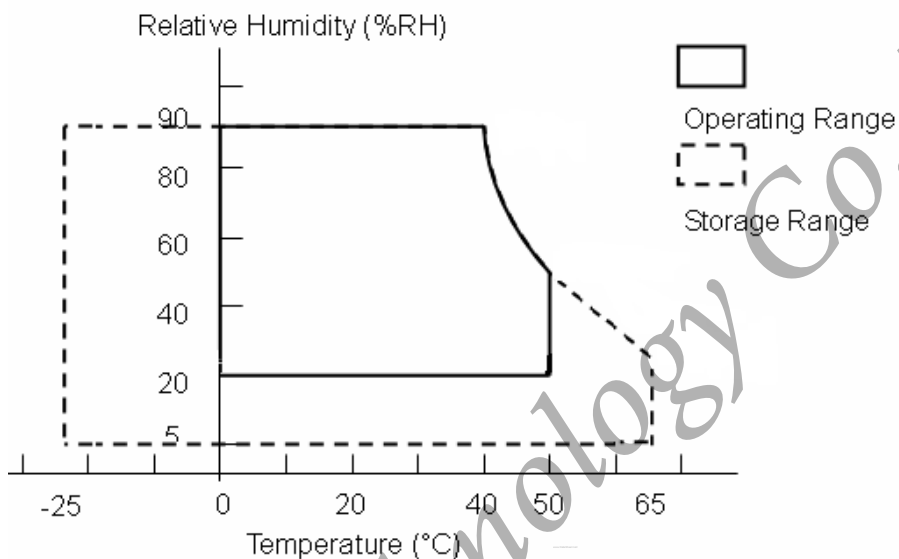

3. ELECTRICAL CHARACTERISTICS

(A) TFT LCD

TEM		SYMBOL	MIN	TYP	MAX	UNIT	NOTE
LCD POWER VOLTAGE		VCC	3.0	3.3	3.6	V	【Note 1】
LCD POWER CURRENT		ICC	-	(TBD)	(TBD)	mA	【Note 2】
Rush CRRENT		Irush	-	-	2	A	【Note 4】
LOGIC INPUT VOLTAGE (LVDS: IN+,IN-)	COMMON VOLTAGE	VCM	1.125	1.25	1.375	V	【Note 3】
	DIFFRENTIAL INPUT VOLTAGE	VID	250	350	450	mV	【Note 3】
	THRESHOLD VOLTAGE (HIGH)	VTH	-	-	100	mV	【Note 3】 When VCM = +1.2V
	THRESHOLD VOLTAGE (LOW)	VTL	-100	-	-	mV	

【Note 1】 Power Sequence :

- 0.5 ms ≤ t1 ≤ 10ms 500 ms ≤ t4
- 0.01 ms < t2 ≤ 50 ms 200 ms ≤ t5
- 0.01 ms < t3 ≤ 50 ms 200 ms ≤ t6

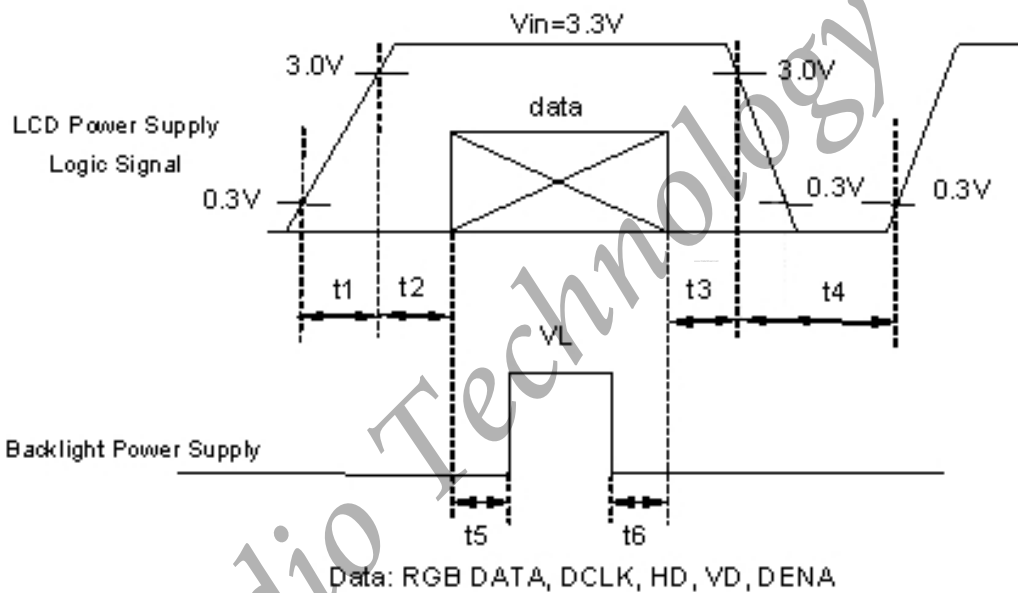

VCC-dip state

- (1) when 3.0 > VCC ≥ 2.7V , td ≤ 10 ms
- (2) when VCC < 2.7V , VCC-dip condition should as the VCC-turn-off condition.

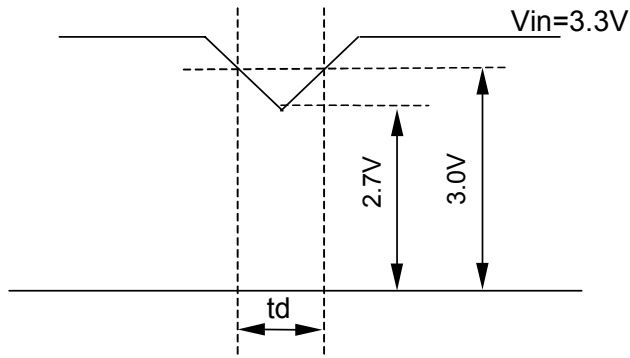

【Note2】 Typical value is Mosaic (32*36 Checker board) Pattern : 600 line mode ◦

Circuit condition (Typ.) :

$V_{CC}=3.3 V$, $f_v=60 Hz$ $f_H=37.5 kHz$, $f_{CLK}=45 MHz$

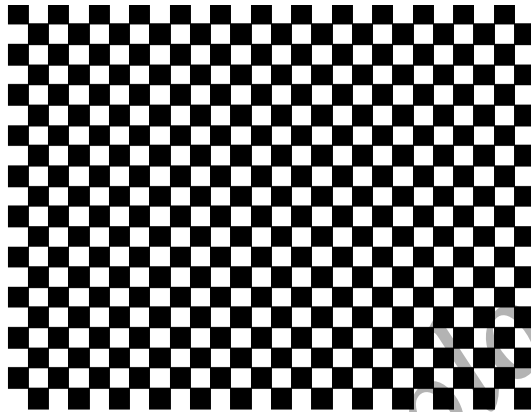

Max value is Black Pattern : 600 line mode ◦

Circuit condition (Max.) : $V_{CC}=3.3 V$, $f_v=60 Hz$ $f_H=37.5 kHz$, $f_{CLK}=45 MHz$



【Note 3】 LVDS Signal Definite

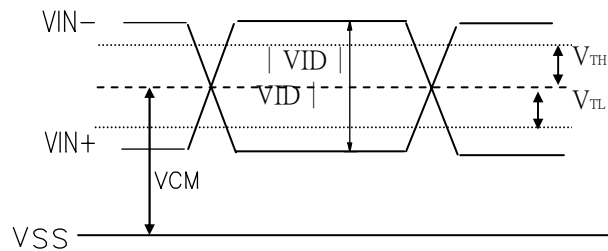
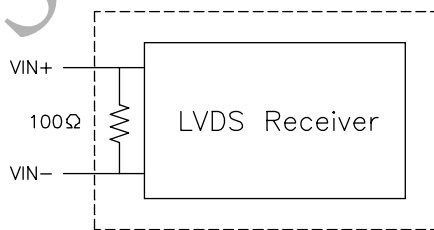

V_{IN+} : Positive differential DATA & CLK Input

V_{IN-} : Negative differential DATA & CLK Input

【Note 4】 Irush measure condition

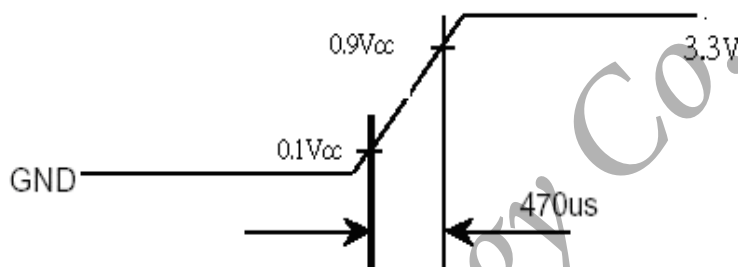
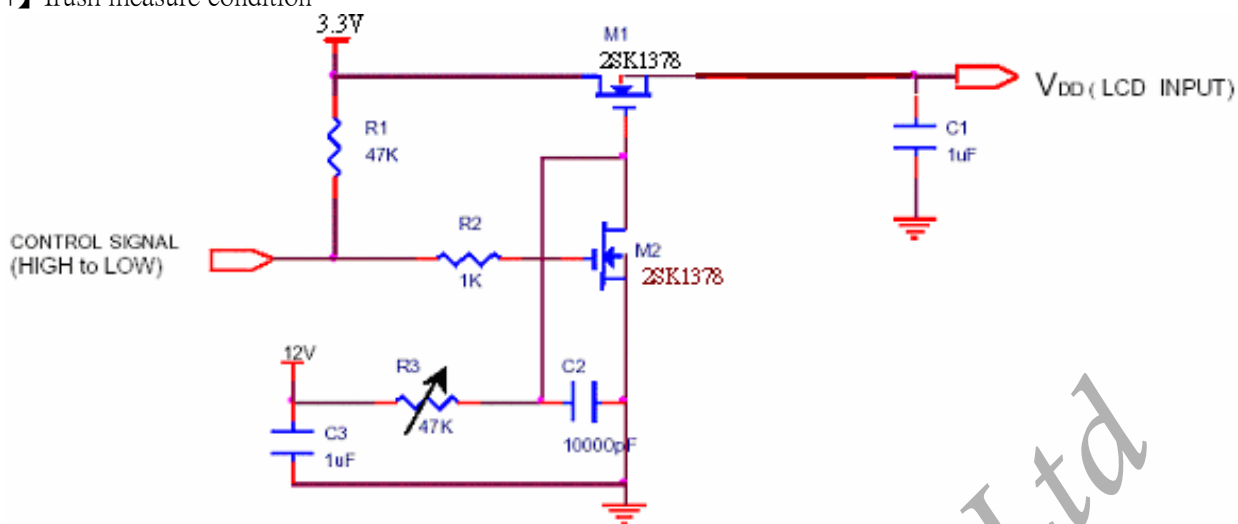

(B) BACK LIGHT

(a.) ELECTRICAL CHARACTERISTICS

Ta=25°C

ITEM	SYMBOL	MIN	TYP	MAX	UNIT	NOTE
LED Driver Input Voltage	VBL+	5	-	21	V	
LED Driver Input Current	IBL+	-	-	(TBD)	mA	*1)
Forward Voltage	VF	2.95	3.3	3.55	V	*2)I _F =20mA
Forward Current	I _F	19.5	20	20.5	mA	*2)
Power consumption	P _{LED}	-	(TBD)	(TBD)	W	*2)*3)I _F =20mA
PWM Frequency	PWM_BL	180	200	220	Hz	
Duty ratio	Dim	10		100	%	

(b) LED LIFE - TIME

ITEM	Condition	min	typ	max	UNIT	NOTE
LIFE TIME	I _F =20mA · Ta=25°C	15000			hrs	*4)

(c) LED ON/OFF Sequence :

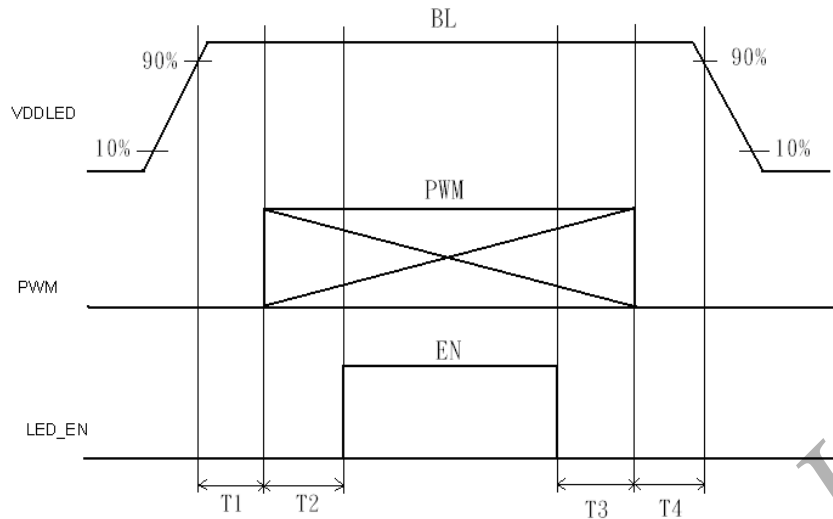

$$10\text{ms} \leq T1 \quad 0\text{ms} \leq T3$$

$$10\text{ms} \leq T2 \quad 10\text{ms} \leq T4$$

Note : The duty of LED dimming signal should be more than 20% in T2 and T3

*1)Typical value ; $V_{BL+} = 12\text{V}$, Duty=100% .

Max value ; $V_{BL+} = 5\text{V}$, Duty=100% .

*2)Measure method : a. LED current is measured by utilizing a current meter as show below.

b. we set up system power input voltage at 12v to measurement PLED.

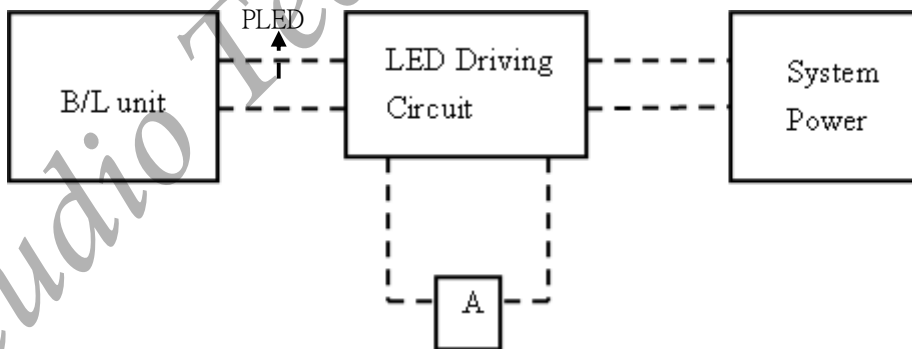

*3) Calculator value for reference $I_F \cdot V_F = P_{LED}$

*4)Life time means that estimated time to 50% degradation of initial luminous intensity.

4. Connector Interface PIN & Function

CN(Interface signal)

Outlet connector: I-PEX 20455-040E-12

Pin No.	SYMBOL	FUNCTION
1	NC	No Connection
2	VDD	Power Supply, 3.3V (typical)
3	VDD	Power Supply, 3.3V (typical)
4	V_EDID	DDC 3.3V power
5	NC	No Connection
6	CLK_EDID	DDC Clock
7	DATA_EDID	DDC Data
8	RxIn0-	-LVDS Differential Data Input
9	RxIn0+	+LVDS Differential Data Input
10	VSS	Ground
11	RxIn1-	-LVDS Differential Data Input
12	RxIn1+	+LVDS Differential Data Input
13	VSS	Ground
14	RxIn2-	-LVDS Differential Data Input
15	RxIn2+	+LVDS Differential Data Input
16	VSS	Ground
17	RxCLK-	-LVDS Differential Clock Input
18	RxCLK+	+LVDS Differential Clock Input
19	VSS	Ground
20	NC	No Connection
21	NC	No Connection
22	VSS	Ground
23	NC	No Connection
24	NC	No Connection
25	VSS	Ground
26	NC	No Connection
27	NC	No Connection
28	VSS	Ground
29	NC	No Connection
30	NC	No Connection
31	LED_GND	LED Ground
32	LED_GND	LED Ground
33	LED_GND	LED Ground
34	NC	No Connection
35	LED_PWM	PWM Control Signal of LED Converter
36	LED_EN	Enable Control Signal of LED Converter
37	NC	No Connection
38	LED_VCC	LED Power Supply 5V-21V
39	LED_VCC	LED Power Supply 5V-21V
40	LED_VCC	LED Power Supply 5V-21V

5. INTERFACE TIMING CHART

(1)(a). LVDS input time sequence

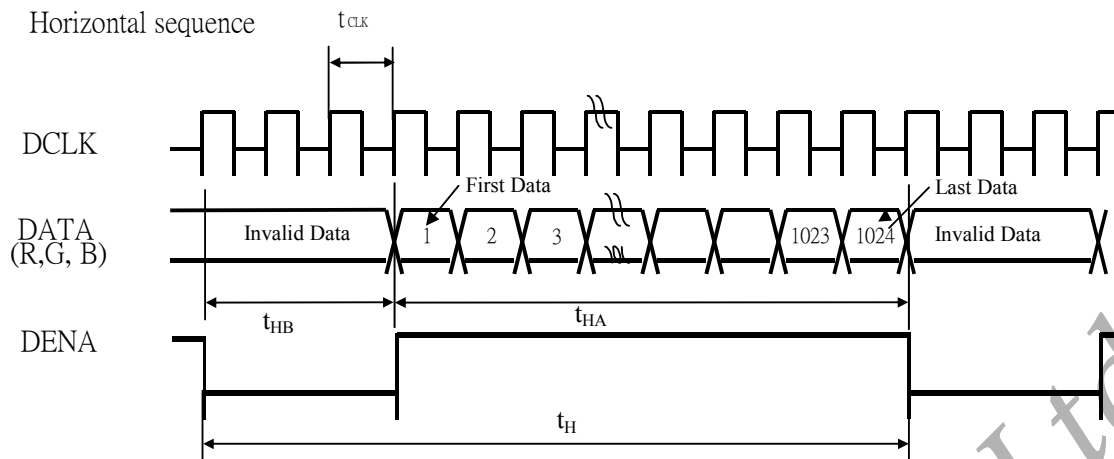

(b) LCD input time sequence

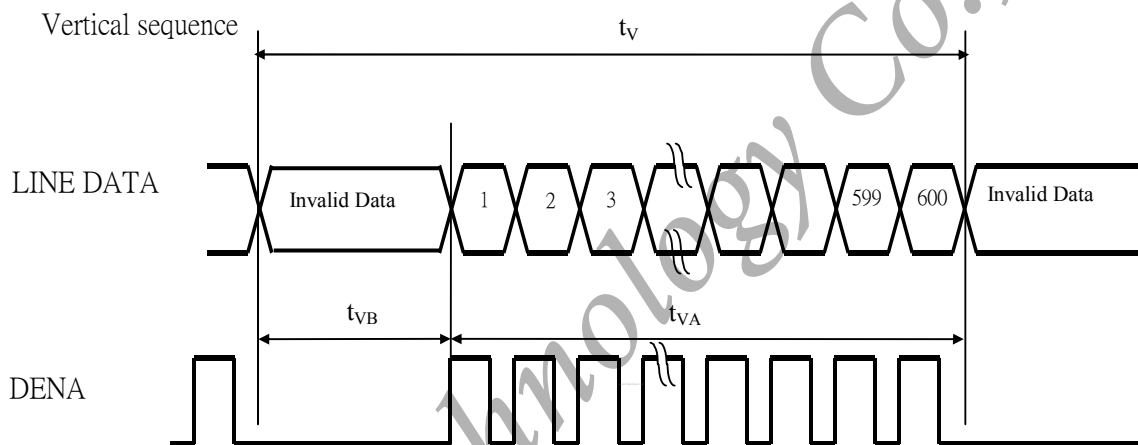

(2) Timing Chart

ITEM		SYMBOL	MIN	TYP	MAX	UNIT		
LCD Timing	Frame Rate	-	(TBD)	60	(TBD)	Hz		
	DCLK	Frequency	f_{CLK}	(TBD)	45	(TBD)	MHz	
		Period	t_{CLK}	(TBD)	22.22	(TBD)	Ns	
	DENA	Horizontal	Horizontal total time	t_H	(TBD)	1200	(TBD)	t_{CLK}
			Horizontal Active time	t_{HA}	1024		t_{CLK}	
			Horizontal Blank time	t_{HB}	(TBD)	176	(TBD)	t_{CLK}
	Vertical	Vertical	Vertical total time	t_V	(TBD)	625	(TBD)	t_H
			Vertical Active time	t_{VA}	600		t_H	
Vertical Blank time			t_{VB}	(TBD)	25	(TBD)	t_H	

【Note】

- *1) DENA (DATA ENABLE) usually is positive.
- *2) During the whole blank period, DCLK should keep input.

(3) DATA mapping

Color	Input Data	R DATA						G DATA						B DATA					
		R5	R4	R3	R2	R1	R0	G5	G4	G3	G2	G1	G0	B5	B4	B3	B2	B1	B0
		MS B					LS B	MS B					LS B	MS B					LS B
Basic Color	Black	0	0	0	0	0	0	0	0	0	0	0	0	0	0	0	0	0	0
	Red(63)	1	1	1	1	1	1	0	0	0	0	0	0	0	0	0	0	0	0
	Green(63)	0	0	0	0	0	0	1	1	1	1	1	1	0	0	0	0	0	0
	Blue(63)	0	0	0	0	0	0	0	0	0	0	0	0	1	1	1	1	1	1
	Cyan	0	0	0	0	0	0	1	1	1	1	1	1	1	1	1	1	1	1
	Magenta	1	1	1	1	1	1	0	0	0	0	0	0	1	1	1	1	1	1
	Yellow	1	1	1	1	1	1	1	1	1	1	1	1	0	0	0	0	0	0
	White	1	1	1	1	1	1	1	1	1	1	1	1	1	1	1	1	1	1
RED	RED(0)	0	0	0	0	0	0	0	0	0	0	0	0	0	0	0	0	0	0
	RED(1)	0	0	0	0	0	1	0	0	0	0	0	0	0	0	0	0	0	0
	RED(2)	0	0	0	0	1	0	0	0	0	0	0	0	0	0	0	0	0	0
	RED(62)	1	1	1	1	1	0	0	0	0	0	0	0	0	0	0	0	0	0
	RED(63)	1	1	1	1	1	1	0	0	0	0	0	0	0	0	0	0	0	0
Green	Green(0)	0	0	0	0	0	0	0	0	0	0	0	0	0	0	0	0	0	0
	Green(1)	0	0	0	0	0	0	0	0	0	0	0	1	0	0	0	0	0	0
	Green(2)	0	0	0	0	0	0	0	0	0	0	1	0	0	0	0	0	0	0
	Green(62)	0	0	0	0	0	0	1	1	1	1	1	0	0	0	0	0	0	0
	Green(63)	0	0	0	0	0	0	1	1	1	1	1	1	0	0	0	0	0	0
Blue	Blue(0)	0	0	0	0	0	0	0	0	0	0	0	0	0	0	0	0	0	0
	Blue(1)	0	0	0	0	0	0	0	0	0	0	0	0	0	0	0	0	0	1
	Blue(2)	0	0	0	0	0	0	0	0	0	0	0	0	0	0	0	0	1	0
	Blue(62)	0	0	0	0	0	0	0	0	0	0	0	0	1	1	1	1	1	0
	Blue(63)	0	0	0	0	0	0	0	0	0	0	0	0	1	1	1	1	1	1

【Note】

- 1) Gray level:
Color(n) : n is level order; higher n means brighter level.
- 2) DATA:
1: high · 0: low

6. BLOCK DIAGRAM

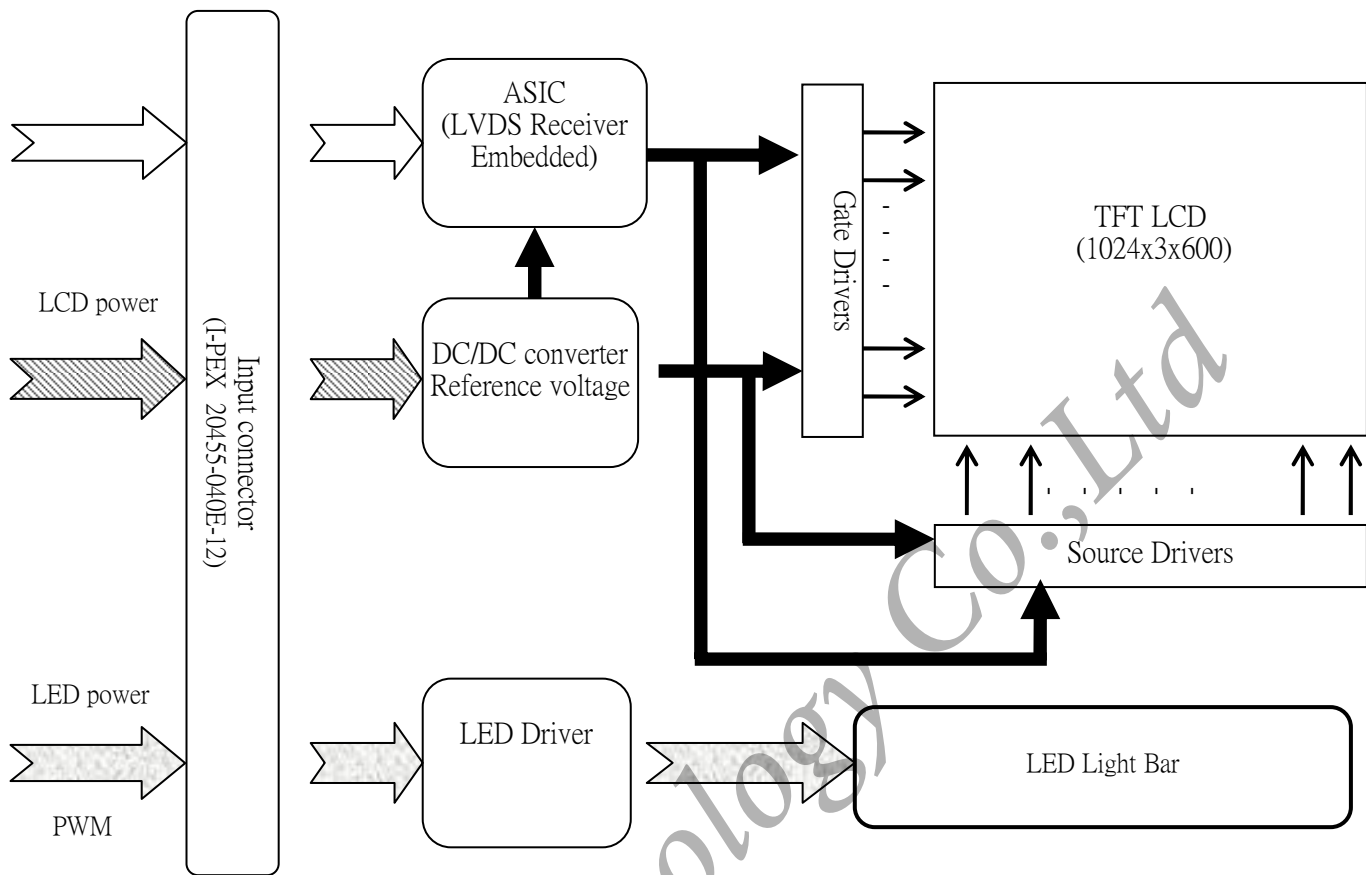

7. MECHANICAL SPECIFICATION

(1) Front side

The tolerance, not show in the figure, is $\pm 0.3\text{mm}$.

[Unit : mm]

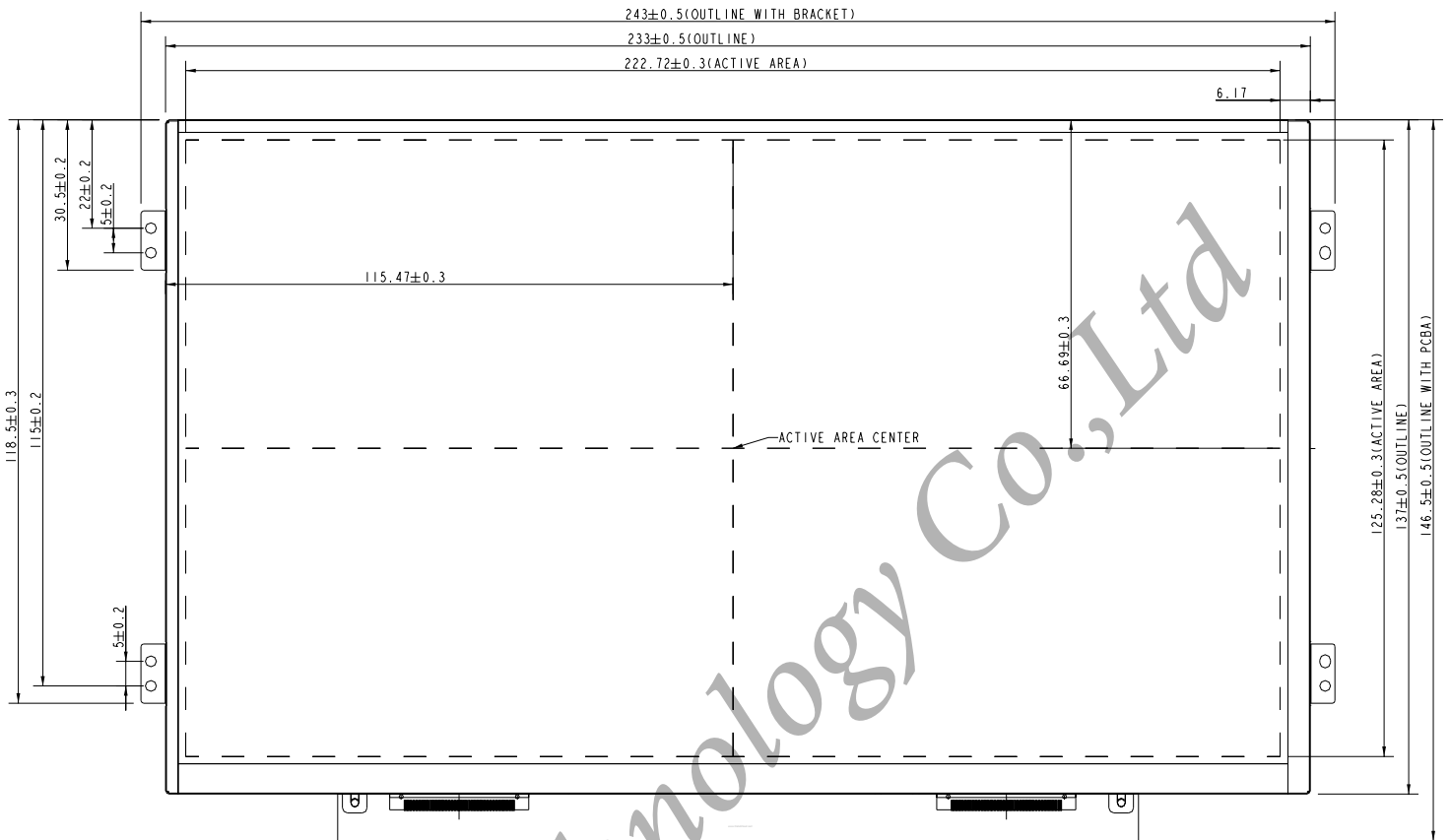

Studio Technology Co., Ltd

2) Rear side

The tolerance, not show in the figure, is $\pm 0.3\text{mm}$.

[Unit : mm]

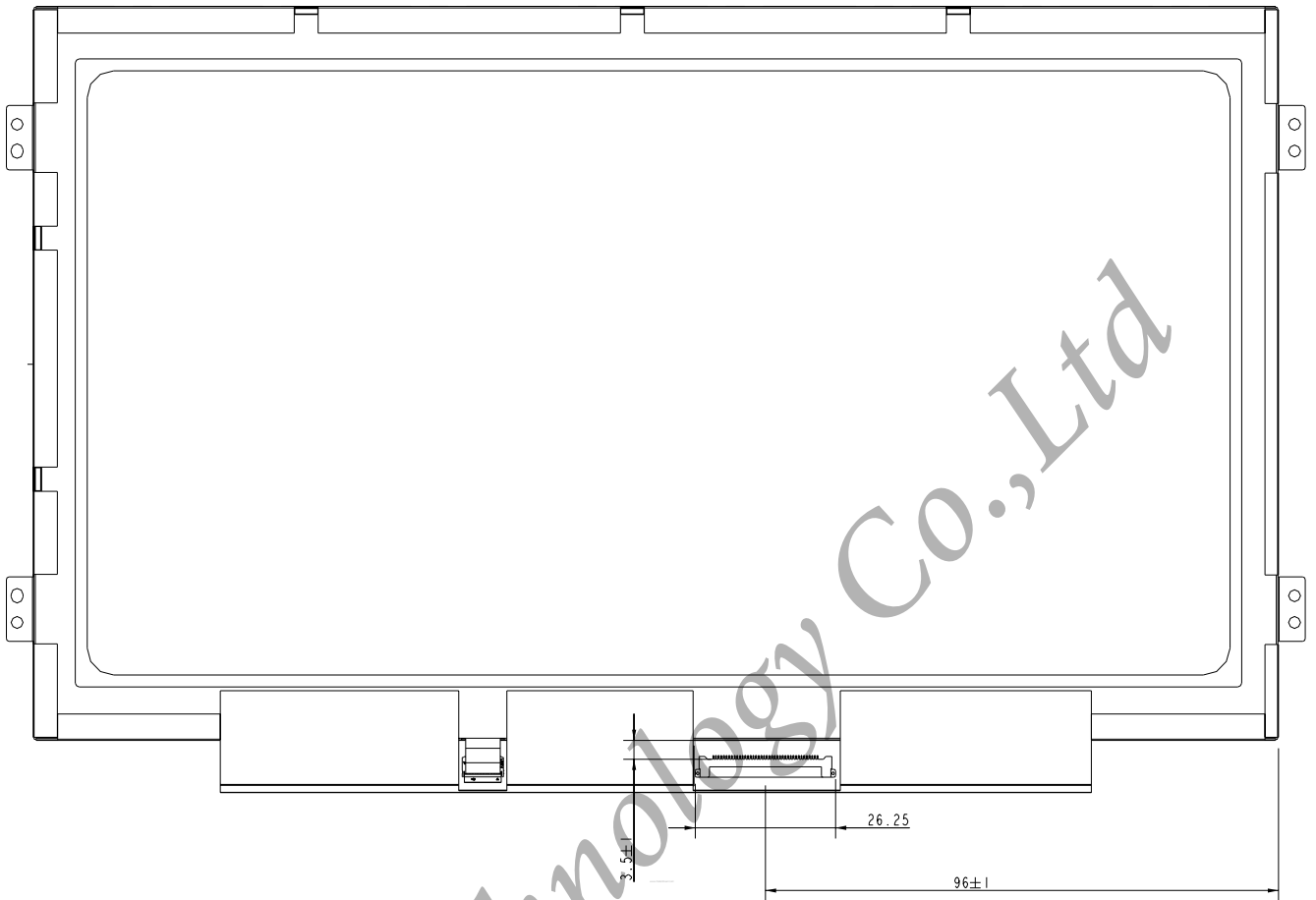

8. OPTICAL CHARACTERISTICS

Ta=25°C , VDD=3.3V

ITEM	SYMBOL	CONDITION	MIN.	TYP.	MAX.	UNIT	NOTE	
Contrast Ratio	CR	$\theta = \psi = 0^\circ$	300	400	-	--	*1) 2)	
Luminance (5P)	L	$\theta = \psi = 0^\circ$	180	200	-	cd/m ²	*1) 3)	
Uniformity(5P)	ΔL	$\theta = \psi = 0^\circ$	80	-	-	%	*1) 3)	
Uniformity(13P)	ΔL	$\theta = \psi = 0^\circ$	65	-	-	%	*1) 3)	
Response Time	Tr+ Tf	$\theta = \psi = 0^\circ$	-	8	16	ms	*5)	
Cross talk	CT	$\theta = \psi = 0^\circ$	-	-	1	%	*6)	
View angle	Horizontal	Ψ	CR \geq 10	-	45/45	-	$^\circ$	*4)
	Vertical	θ		-	15/35	-	$^\circ$	*4)
Color Temperature Coordinate	W	X	$\theta = \psi = 0^\circ$	0.293	0.313	0.333	*3)	
		Y		0.309	0.329	0.349		
	R	X		(TBD)	(TBD)	(TBD)		
		Y		(TBD)	(TBD)	(TBD)		
	G	X		(TBD)	(TBD)	(TBD)		
		Y		(TBD)	(TBD)	(TBD)		
B	X	(TBD)	(TBD)	(TBD)				
	Y	(TBD)	(TBD)	(TBD)				
Gamut		$\theta = \psi = 0^\circ$	42	45		%		
Gamma	γ	GL	2.0	2.2	2.4		*7)	

Color coordinate and color gamut are measured by SRUL1R, response time is measured by TRD-100, and all the other items are measured by BM-5A (TOPCON). All these items are measured under the dark room condition (no ambient light).

Measurement Condition: IL=20mA(each LED)

Definition of these measurement items is as follows:

***1) Setup of Measurement Equipment**

The LCD module should be turn-on to a stable luminance level to be reached. The measurement should be executed after lighting Backlight for 20 minutes and in a dark room.

***2) Definition of Contrast Ratio**

CR=ON (White) Luminance/OFF (Black) Luminance

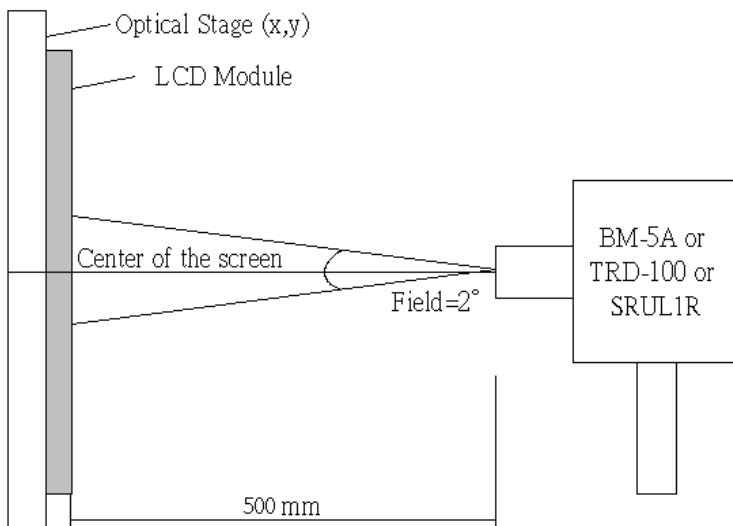

***3) Definition of Luminance and Luminance uniformity**

Central luminance: The white luminance is measured at the center position “5” on the screen, see Fig.1 below.

5P Luminance (AVG): The white luminance is measured at measuring points 5、10、11、12、13, see Fig.1 below.

5P Uniformity: $\Delta L = (L_{min} / L_{max}) \times 100\%$

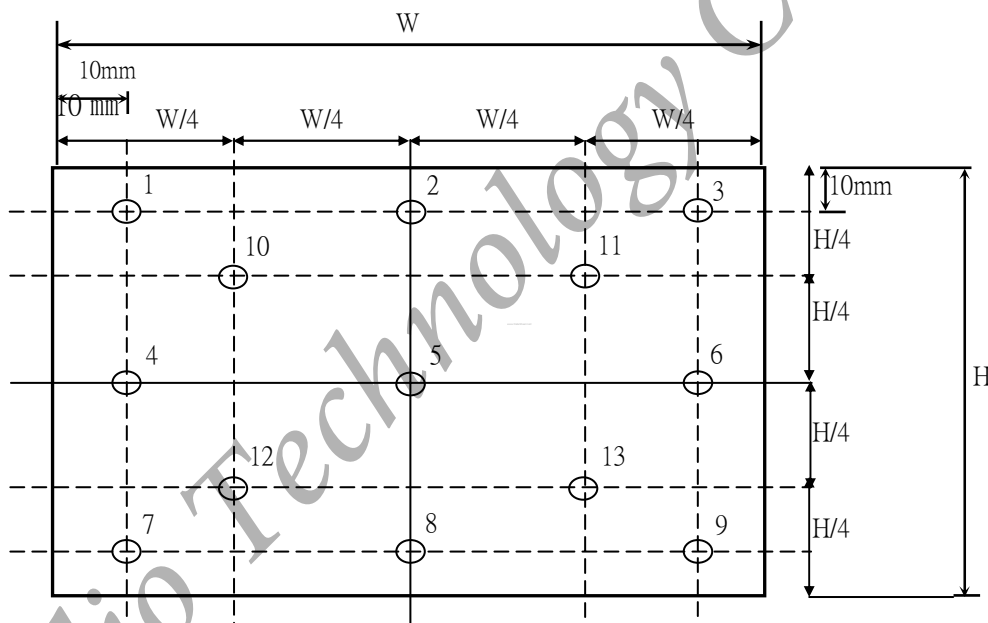
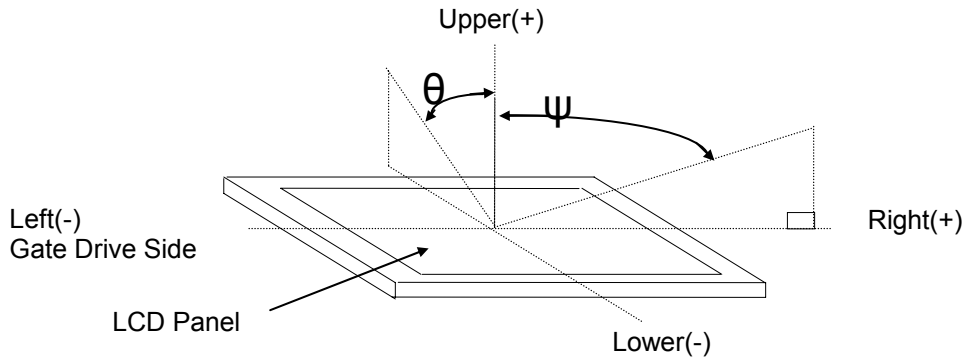
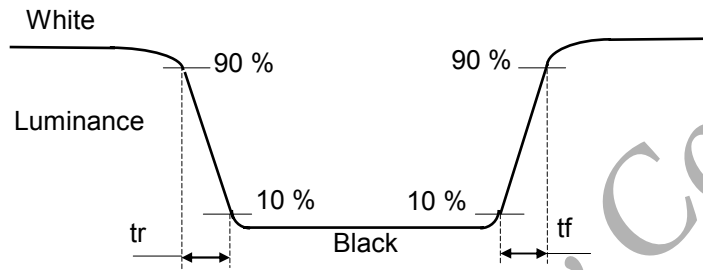

Fig.1 Measure point (Active area)

*4) Definition of view angle(θ , ψ)



*5) Definition of response time



*6) Crosstalk Modulation Ratio:

$$CT = | Y_B - Y_A | / Y_{A, \times} \times 100\%$$

Y_A , Y_B measure position and definition

Y_A means luminance at gray level 31(exclude gray level 0 pattern)

Y_B means luminance at gray level 31(include gray level 0 pattern)

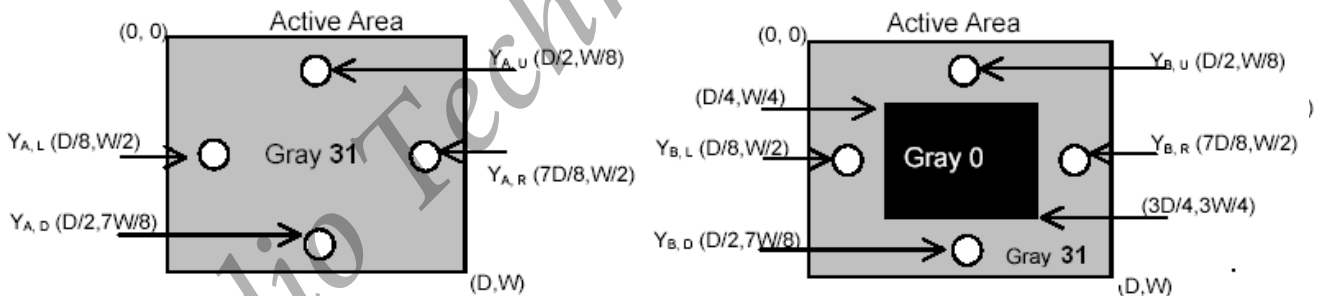

*7) Definition Gamma (VESA)

Based on Customer Sample, take the average value as a standard center value and the variation range of gamma value caused by loop voltage error should be between +/- 0.2. the bellow figure shows how to obtain the gamma curve and γ (from gray level: 0 , 4 , 8-----60 , 63).

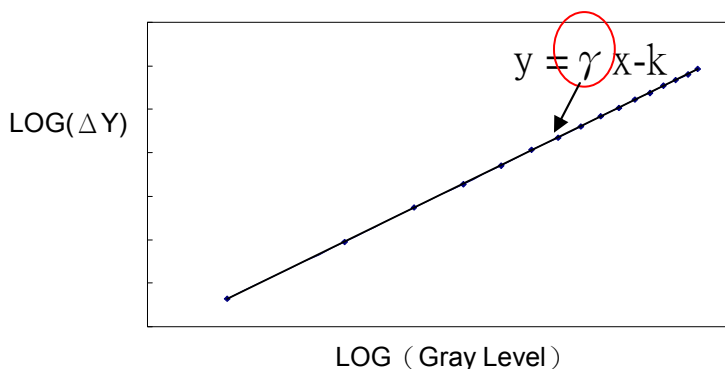

9. RELIABILITY TEST CONDITIONS

(1) Temperature 、 Humidity and Pressure

TEST ITEMS	CONDITIONS
High Temperature Operation	50° C ; 250Hrs
High Temperature Storage	65° C ; 250Hrs
High Temperature High Humidity Operation	40° C ; 95% RH ; 250Hrs
High Temperature High Humidity Storage	60° C ; 95% RH ; 48 Hrs
Low Temperature Operation	0° C ; 250 Hrs
Low Temperature Storage	-25° C ; 250 Hrs
Thermal Shock	-40° C (30 Mins) ~ 65° C (30 Mins) , 100 CYCLE
Low Temperature Low Pressure Storage	0° C 、 260hPa 、 24 Hrs

(2) Shock & Vibration

TEST ITEMS	CONDITIONS
Shock (Non-Operation)	220G, 2ms, half sin wave, ± X, ± Y, ± Z 1 time each
Vibration (Non-Operation)	Vibration level : 1.5G, sinusoidal wave (each x, y, z axis : 1hr, total 3hrs) Frequency range : 5 ~ 500 Hz Sweep speed : 0.5 Octave/min.

(3) MTBF without B/L : 200,000 Hrs(min) lifetime.

(4) Judgment standard

The judgment of the above test should be made as follow:

Pass : Normal display image with no obvious non-uniformity and no line defect.

Partial transformation of the module parts should be ignored.

Fail : No display image, obvious non-uniformity, or line defects.