

# mass integrated

global part distribution • product lifecycle partner  
excess inventory management • value-ad service provider



Data sheet provided by Mass Integrated

[massintegrated.com](http://massintegrated.com) • [displayalliance.com](http://displayalliance.com)

Please call +1.978.465.6190  
Email: [sales@massintegrated.com](mailto:sales@massintegrated.com)



ISO 9001: 2008

Mass Integrated complies with all DMCA takedown notices. Please send a formal DMCA Takedown Notice to Mass Integrated Systems, Inc. • 18 Henry Graf Jr. Road, Unit 1 • Newburyport, MA 01950.



# Specification

**CLAA102NA0BCW**

**10.2" / 1024x600 / LVDS / LED**

**Version 0.2**

**December 2008**



# CONTENTS

<b>1. OVERVIEW</b> .....	<b>4</b>
<b>2. ABSOLUTE MAXIMUM RATINGS</b> .....	<b>5</b>
<b>3. ELECTRICAL CHARACTERISTICS</b> .....	<b>6</b>
3.1 TFT LCD Power Voltage .....	6
3.2 TFT-LCD Current Consumption .....	7
3.3 Power 、 Signal sequence .....	7
<b>4. INTERFACE CONNECTION</b> .....	<b>8</b>
<b>5. INPUT SIGNAL</b> .....	<b>9</b>
5.1 Timing Specification .....	9
5.2 Timing sequence (Timing chart).....	9
5.3 Color data assignment.....	11
<b>6. BLOCK DIAGRAM</b> .....	<b>12</b>
<b>7. MECHANICAL DIMENSION</b> .....	<b>13</b>
7.1 Front Side .....	13
7.2 Rear Side .....	14
<b>8. OPTICAL CHARACTERISTICS</b> .....	<b>15</b>
<b>9. RELIABILITY TEST</b> .....	<b>17</b>
9.1. Temperature and humidity .....	17
9.2. Shock and Vibration .....	17
9.3. ESD Test.....	17
9.4 Judgment Standard .....	17
<b>10. APPEXNDIX EDID CODE TABLE</b> .....	<b>18</b>

## 1. OVERVIEW

CLAA102NA0BCW is 25.8 cm(10.2") color TFT-LCD (Thin Film Transistor Liquid Crystal Display) module composed of LCD panel, driver ICs, control circuit, and backlight.

The 10.2" screen produces a high resolution image that is composed of 1024×600 pixel elements in a stripe arrangement. Display 262K colors by 6 Bit R.G.B signal input. Use 3.3 voltage to drive the power of LCD system, and 5.0 Voltage to drive the LED back light.

General specification are summarized in the following table:

ITEM	SPECIFICATION			
Panel Size	10.2 inch(panel diagonal)			
Display Area (mm)	222.72(H) x 130.5(V) (10.2-inch diagonal)			
Number of Pixels	1024(H) × 3(RGB) × 600(V)			
Pixel Pitch (mm)	0.2175 (H) × 0.2175 (V)			
Color Pixel Arrangement	RGB vertical stripe			
Display Mode	Normally white			
Number of colors	262,144			
Brightness(cd/m <sup>2</sup> )	220(typ.)			
Response Time (Tr+Tf)	20 ms			
Outline Dimension(mm)		Min.	Typ.	Max.
	Horizontal (H)	234.7	235	235.3
	Vertical (V)	145.5	145.8	146.1
	Depth (D)			5.5
Viewin Angle(BL on,CR≥10)	140 degree(H) · 120 degree(V)			
Power consumption (W)	3.5			
BL unit	LED			
Electrical Interface(data)	LVDS			
Viewing Direction	6 o'clock			
Weight(g)	250			
Surface Treament	Anti-Glare · Hardness:3H			

## 2. ABSOLUTE MAXIMUM RATINGS

The following are maximum values which, if exceeded, may cause faulty operation or damage to the unit.

ITEM	SYMBOL	MIN.	MAX.	UNIT	NOTE
Power Supply Voltage	V <sub>cc</sub>	-0.3	4.0	V	
LED Supply Voltage	V <sub>LED</sub>	-0.3	6.0	V	
Static Electricity	VESD <sub>c</sub>	-200	200	V	【Note2】
	VESD <sub>m</sub>	-15K	15K	V	
ICC Rush Current	IRUSH	-	1	A	【Note 3】
Operation Temperature	T <sub>op</sub>	-20	70	°C	【Note 1】
Storage Temperature	T <sub>stg</sub>	-30	80	°C	【Note 1】

【Note】

【Note1】 If users use the product out off the environment operation range ( temperature and humidity ) ,it will concern for visual quality.

【Note2】 Test Condition: IEC 61000-4-2 ,  
VESD<sub>c</sub> : Contact discharge to input connector  
VESD<sub>m</sub> : Discontact discharge to module

【Note3】 The input pulse-current measurement system as below :

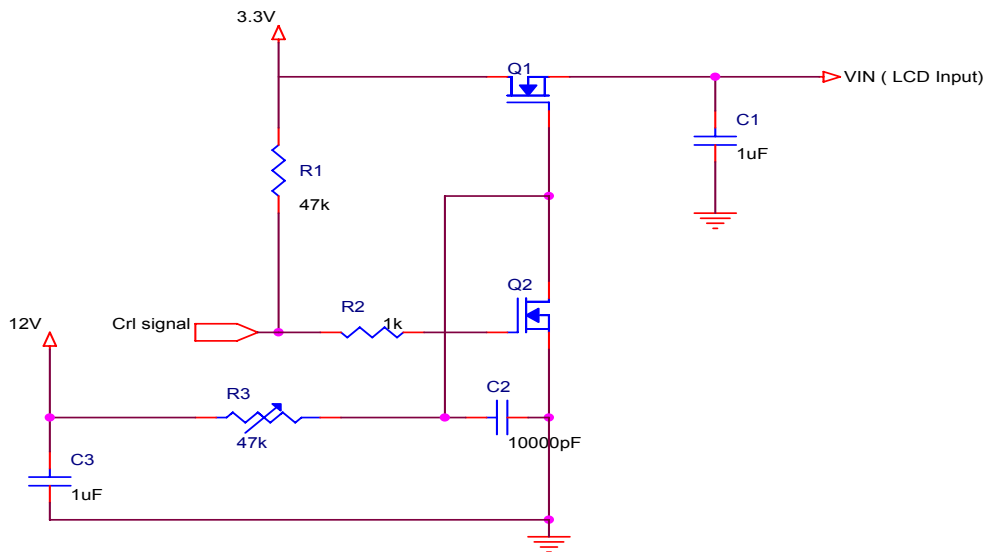

Control signal:High(+3.3V)→Low(GND)

Supply Voltage of rising time should be from R3 and C2 tune to 550 us.

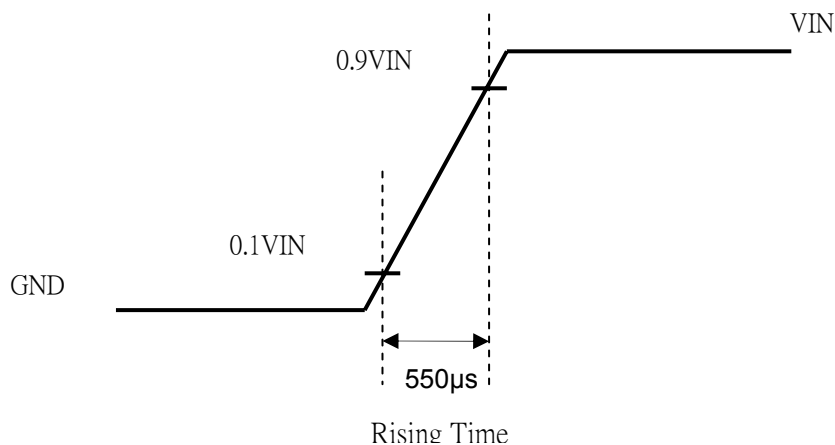

### 3. ELECTRICAL CHARACTERISTICS

#### 3.1 TFT LCD Power Voltage

Ta=25°C

ITEM	SYMBOL	MIN.	TYP.	MAX.	UNIT	NOTE	
Power Supply Voltage For LCD	V <sub>CC</sub>	3.0	3.3	3.6	V	【Note 1】	
Power Supply Voltage For LED	V <sub>LED</sub>	4.5	5	5.5	V		
Logic Input Voltage (LVDS:IN+,IN-)	Input Voltage	V <sub>IN</sub>	0	-	V <sub>CC</sub>	V	【Note 2】
	Common Mode Voltage	V <sub>CM</sub>	1.08	1.2	1.32	V	【Note 2】
	Differential Input Voltage	V <sub>ID</sub>	250	350	450	mV	【Note 2】
	Threshold Voltage(high)	V <sub>TH</sub>	-	-	100	mV	【Note 2】
	Threshold Voltage(low)	V <sub>TL</sub>	-100	-	-	mV	【Note 2】
ADJ Input Voltage	Input Voltage(high)	V <sub>IH</sub>	3.0	3.3	V		
	Input Voltage(low)	V <sub>IL</sub>	GND		0.3	V	

Remarks :

【Note1】 VCC –dip condition:

- 1) When  $2.7\text{ V} \leq V_{CC} < 3.0\text{V}$  ,  $t_d \leq 10\text{ms}$ .
- 2)  $V_{CC} > 3.0\text{V}$  , VCC-dip condition should be same as VCC-turn-on condition.

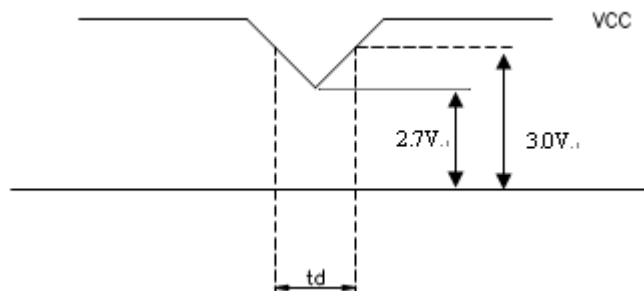

【Note 1】 LVDS signal

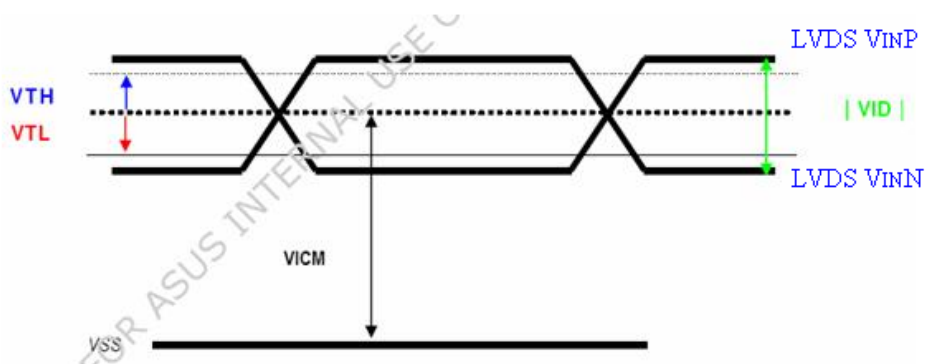

### 3.2 TFT-LCD Current Consumption

ITEM	SYMBOL	MIN.	TYP.	MAX.	UNIT	NOTE
LCD Power Current	$I_{CC}$	--	TBD	--	mA	【Note1】
LED Power Current	$I_{LED}$	--	TBD	--	mA	【Note2】

【Note1】 ( Frame rate = 60 Hz )

Typical: Under 64 gray pattern @  $V_{CC} = 3.3\text{ V}$

Maximum: Under black pattern @  $V_{CC} = 3.0\text{ V}$



(a) 64 Gray Pattern

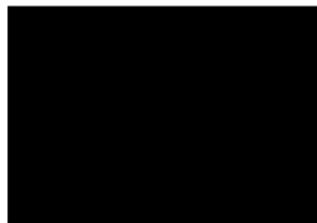

(b) Black Pattern

【Note2】 Typical: When  $V_{LED}$  is 5V

Maximum: When  $V_{LED}$  is 4.5V

### 3.3 Power · Signal sequence

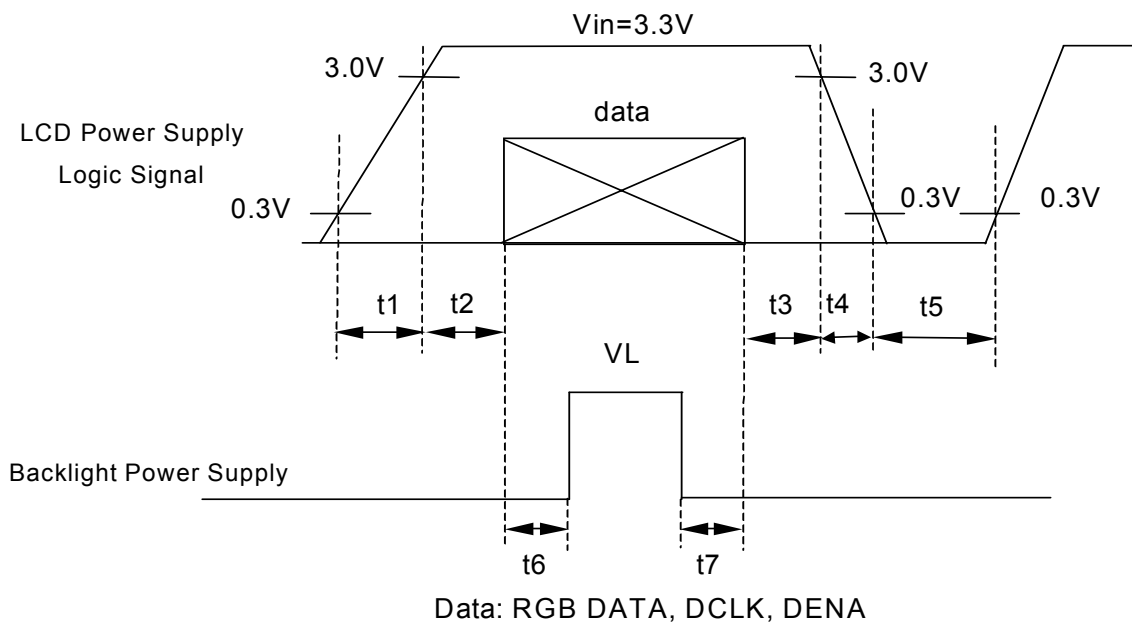

$$0.5 < t1 \leq 10\text{ms}$$

$$0 < t2 \leq 50\text{ms}$$

$$0 < t3 \leq 50\text{ms}$$

$$0 < t4 \leq 10\text{ms}$$

$$200\text{ms} \leq t5$$

$$200\text{ms} \leq t6$$

$$200\text{ms} \leq t7$$



## 4. INTERFACE CONNECTION

CN1 : Connector type : 093F30-B0B01A or compatible.

Pin No.	SYMBOL	FUNCTION
1	GND	Ground
2	V <sub>CC</sub>	+3.3V Power
3	V <sub>CC</sub>	+3.3V Power
4	V <sub>EDID</sub>	3.3V Power for NB
5	ADJ	Adjust for LED brightness
6	CLK_EDID	EDID Clock for NB
7	DATA_EDID	EDID Data for NB
8	RXIN0-	LVDS Signal(-)—channel 0
9	RXIN0+	LVDS Signal(+)—channel 0
10	GND	Ground
11	RXIN1-	LVDS Signal(-)—channel 1
12	RXIN1+	LVDS Signal(+)—channel 1
13	GND	Ground
14	RXIN2-	LVDS Signal(-)—channel 2
15	RXIN2+	LVDS Signal(+)—channel 2
16	GND	Ground
17	RXCLKIN-	LVDS Clock Signal(-)
18	RXCLKIN+	LVDS Clock Signal(+)
19	GND	Ground
20	NC	NC
21	NC	NC
22	GND	Ground
23	GND	Ground
24	V <sub>LED</sub>	Power Supply for LED(V <sub>LED</sub> =5.0±0.5)
25	V <sub>LED</sub>	Power Supply for LED(V <sub>LED</sub> =5.0±0.5)
26	V <sub>LED</sub>	Power Supply for LED(V <sub>LED</sub> =5.0±0.5)
27	NC	NC
28	NC	NC
29	NC	NC
30	NC	NC

### 【Note】

1) ADJ adjust brightness to control Pin , Pulse duty the bigger the brighter.

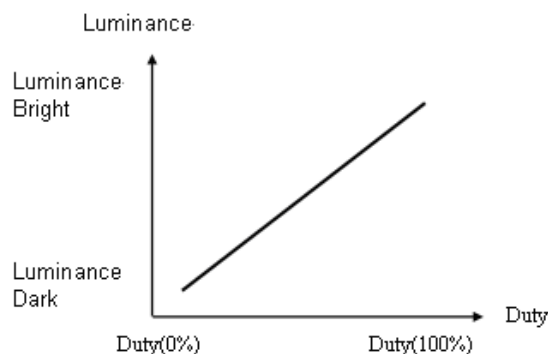

2) ADJ signal=0~3.3V , operation frequency : 25KHZ±5KHZ, ADJ pin should not connect to GND, it should pull-high if not adjust brightness.

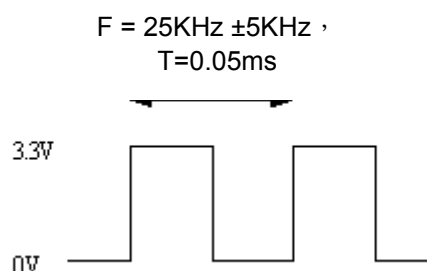

3) GND Pin must ground contact , can not be floating.

## 5. INPUT SIGNAL

### 5.1 Timing Specification

ITEM			SYMBOL	MIN.	TYP.	MAX.	UNIT
LVDS input signal sequence	CLK Frequency		fCLKin	39.05	45	50	MHz
	CLK Period		tCLKin	25.61	22.22	20.00	ns
LCD input timing	Horizontal	Horizontal Period	t <sub>H</sub>	1160	1200	1240	tCLK
		Horizontal Valid	t <sub>HA</sub>	1024	1024	1024	tCLK
		Horizontal Blank	t <sub>HB</sub>	136	176	216	tCLK
	Vertical	Frame	fV	55	60	65	Hz
		Vertical Period	t <sub>V</sub>	612	625	638	t <sub>H</sub>
		Vertical Valid	t <sub>VA</sub>	600	600	600	t <sub>H</sub>
		Vertical Blank	t <sub>VB</sub>	12	25	38	t <sub>H</sub>

### 5.2 Timing sequence (Timing chart)

#### 5.2.1 Horizontal Timing Sequence

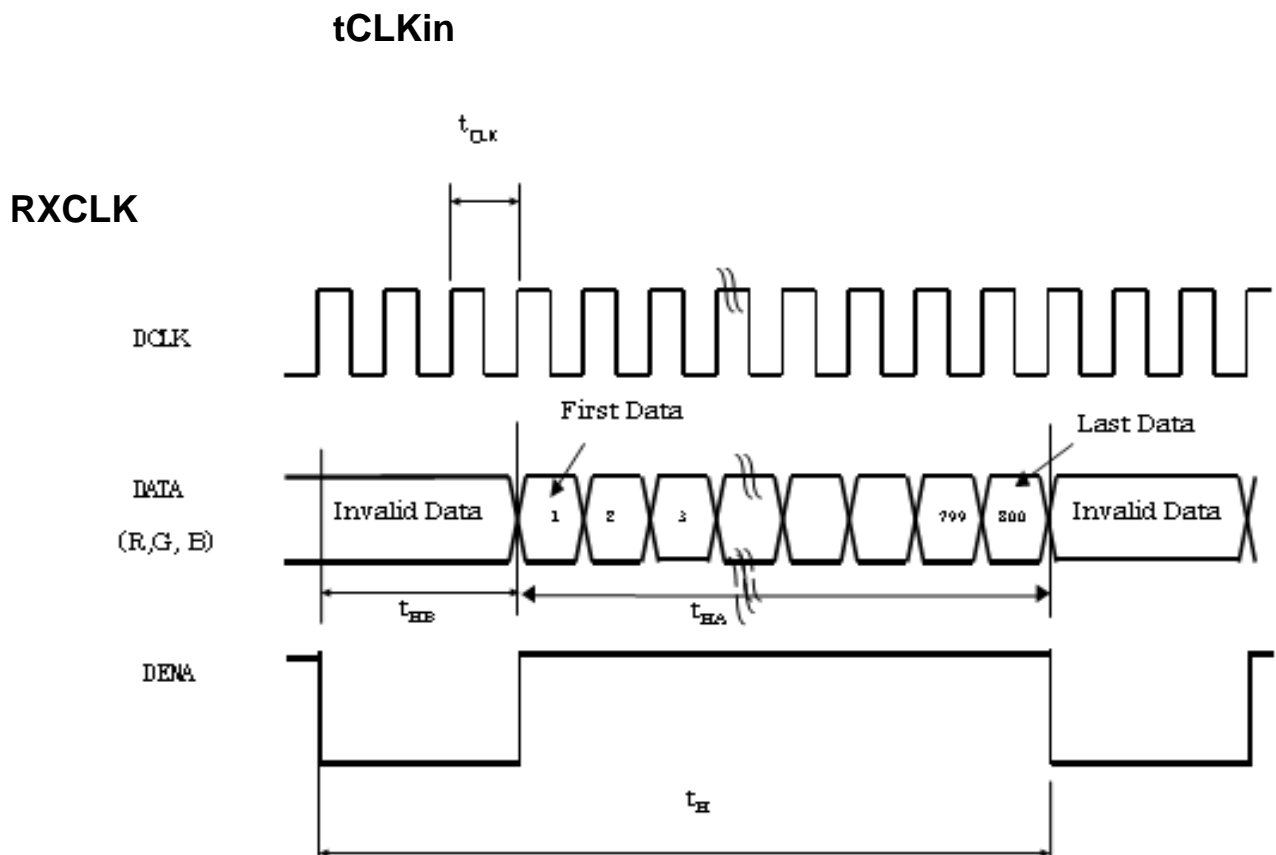

### 5.2.2 Vertical Timing Sequence

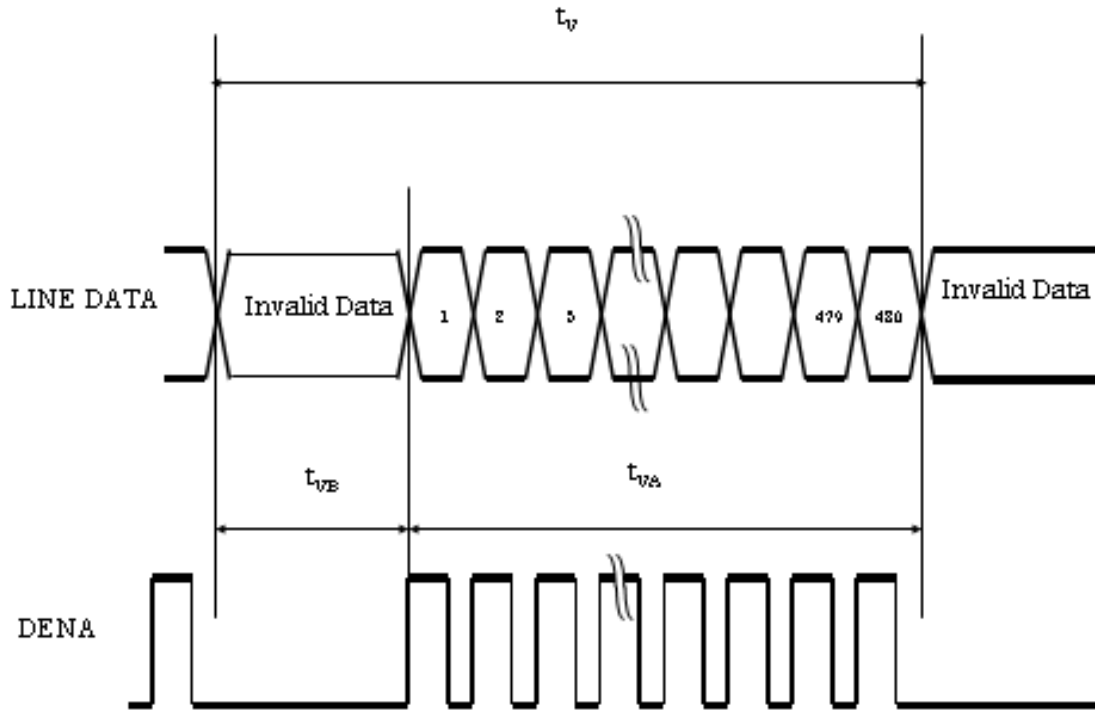

### 5.2.3 LVDS Input Data mapping

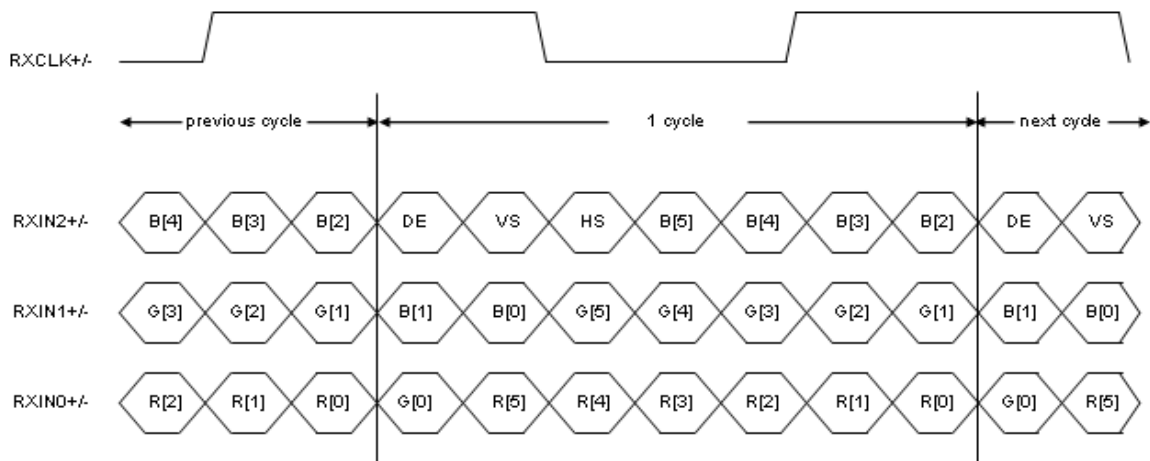

### 5.3 Color data assignment

COLOR	INPUT	R DATA						G DATA						B DATA					
	DATA	R5	R4	R3	R2	R1	R0	G5	G4	G3	G2	G1	G0	B5	B4	B3	B2	B1	B0
		MSB					LSB	MSB					LSB	MSB					LSB
BASIC COLOR	BLACK	0	0	0	0	0	0	0	0	0	0	0	0	0	0	0	0	0	0
	RED(63)	1	1	1	1	1	1	0	0	0	0	0	0	0	0	0	0	0	0
	GREEN(63)	0	0	0	0	0	0	1	1	1	1	1	1	0	0	0	0	0	0
	BLUE(63)	0	0	0	0	0	0	0	0	0	0	0	0	1	1	1	1	1	1
	CYAN	0	0	0	0	0	0	1	1	1	1	1	1	1	1	1	1	1	1
	MAGENTA	1	1	1	1	1	1	0	0	0	0	0	0	1	1	1	1	1	1
	YELLOW	1	1	1	1	1	1	1	1	1	1	1	1	0	0	0	0	0	0
	WHITE	1	1	1	1	1	1	1	1	1	1	1	1	1	1	1	1	1	1
RED	RED(0)	0	0	0	0	0	0	0	0	0	0	0	0	0	0	0	0	0	0
	RED(1)	0	0	0	0	0	1	0	0	0	0	0	0	0	0	0	0	0	0
	RED(2)	0	0	0	0	1	0	0	0	0	0	0	0	0	0	0	0	0	0
	RED(62)	1	1	1	1	1	0	0	0	0	0	0	0	0	0	0	0	0	0
	RED(63)	1	1	1	1	1	1	0	0	0	0	0	0	0	0	0	0	0	0
GREEN	GREEN(0)	0	0	0	0	0	0	0	0	0	0	0	0	0	0	0	0	0	0
	GREEN(1)	0	0	0	0	0	0	0	0	0	0	0	1	0	0	0	0	0	0
	GREEN(2)	0	0	0	0	0	0	0	0	0	0	1	0	0	0	0	0	0	0
	GREEN(62)	0	0	0	0	0	0	1	1	1	1	1	0	0	0	0	0	0	0
	GREEN(63)	0	0	0	0	0	0	1	1	1	1	1	1	0	0	0	0	0	0
BLUE	BLUE(0)	0	0	0	0	0	0	0	0	0	0	0	0	0	0	0	0	0	0
	BLUE(1)	0	0	0	0	0	0	0	0	0	0	0	0	0	0	0	0	0	1
	BLUE(2)	0	0	0	0	0	0	0	0	0	0	0	0	0	0	0	0	1	0
	BLUE(62)	0	0	0	0	0	0	0	0	0	0	0	0	1	1	1	1	1	0
	BLUE(63)	0	0	0	0	0	0	0	0	0	0	0	0	1	1	1	1	1	1

【Note1】 Definition of Gray Scale

color(n) : n is series of Gray Scale. The more n value is, the bright Gray Scale.

【Note2】 Data:1-High,0-Low

## 6. BLOCK DIAGRAM

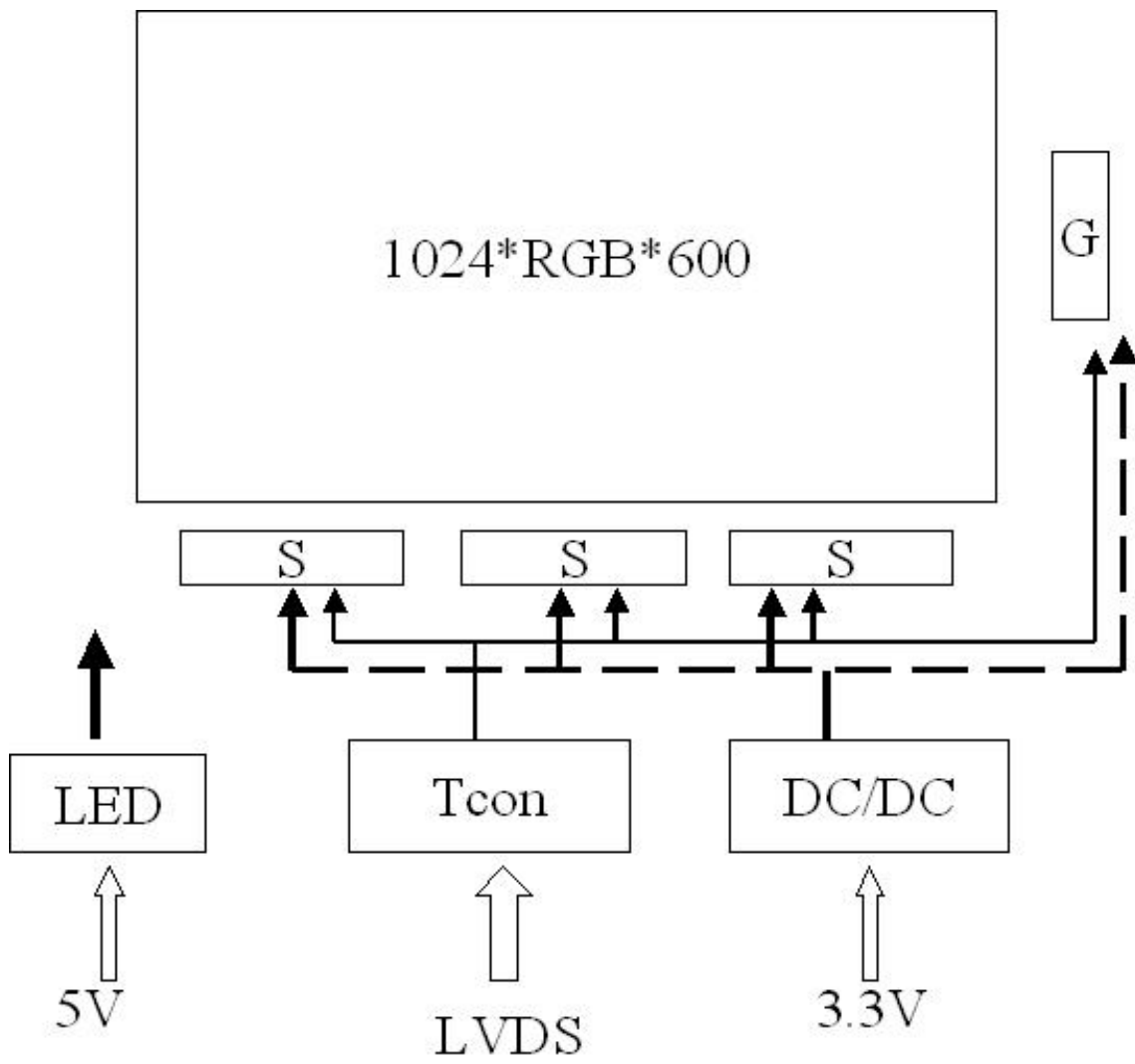

## 7. MECHANICAL DIMENSION

### 7.1 Front Side

[Unit : mm]

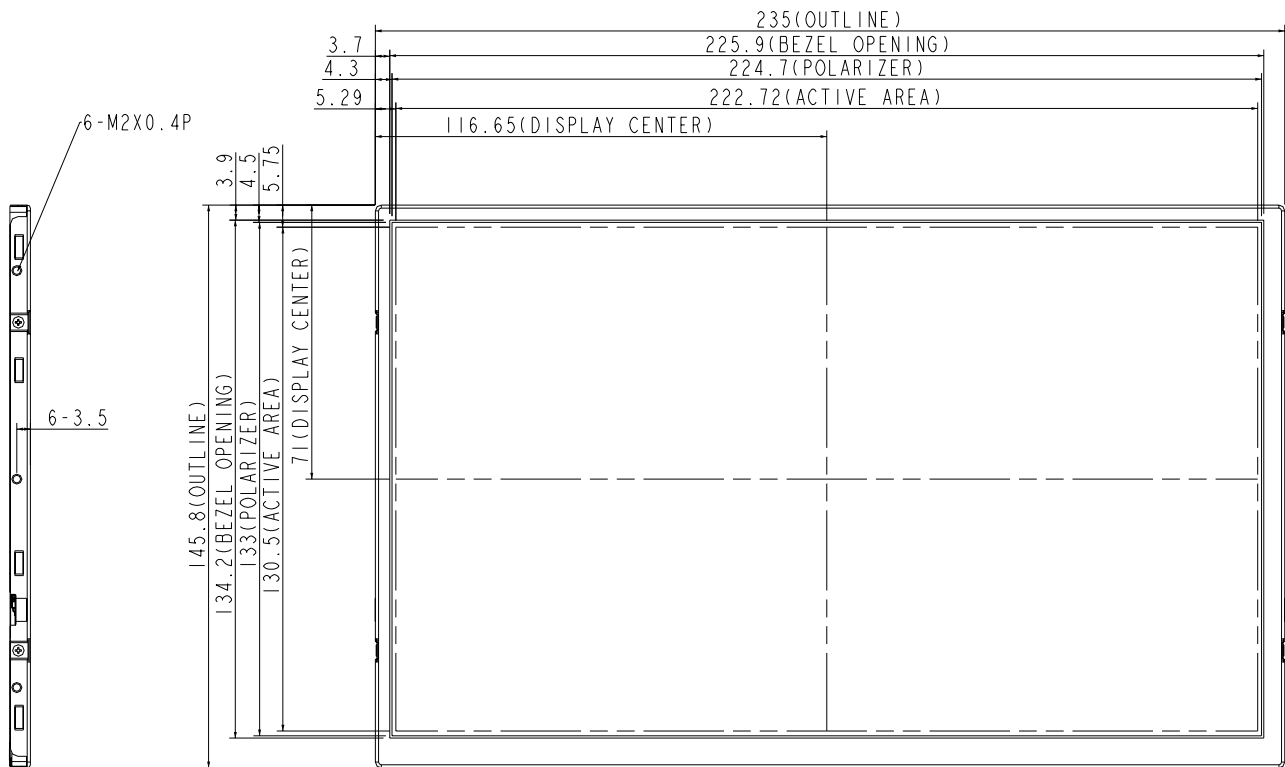

[Note] : Tolerance is  $\pm 0.3\text{mm}$  unless noted

## 7.2 Rear Side

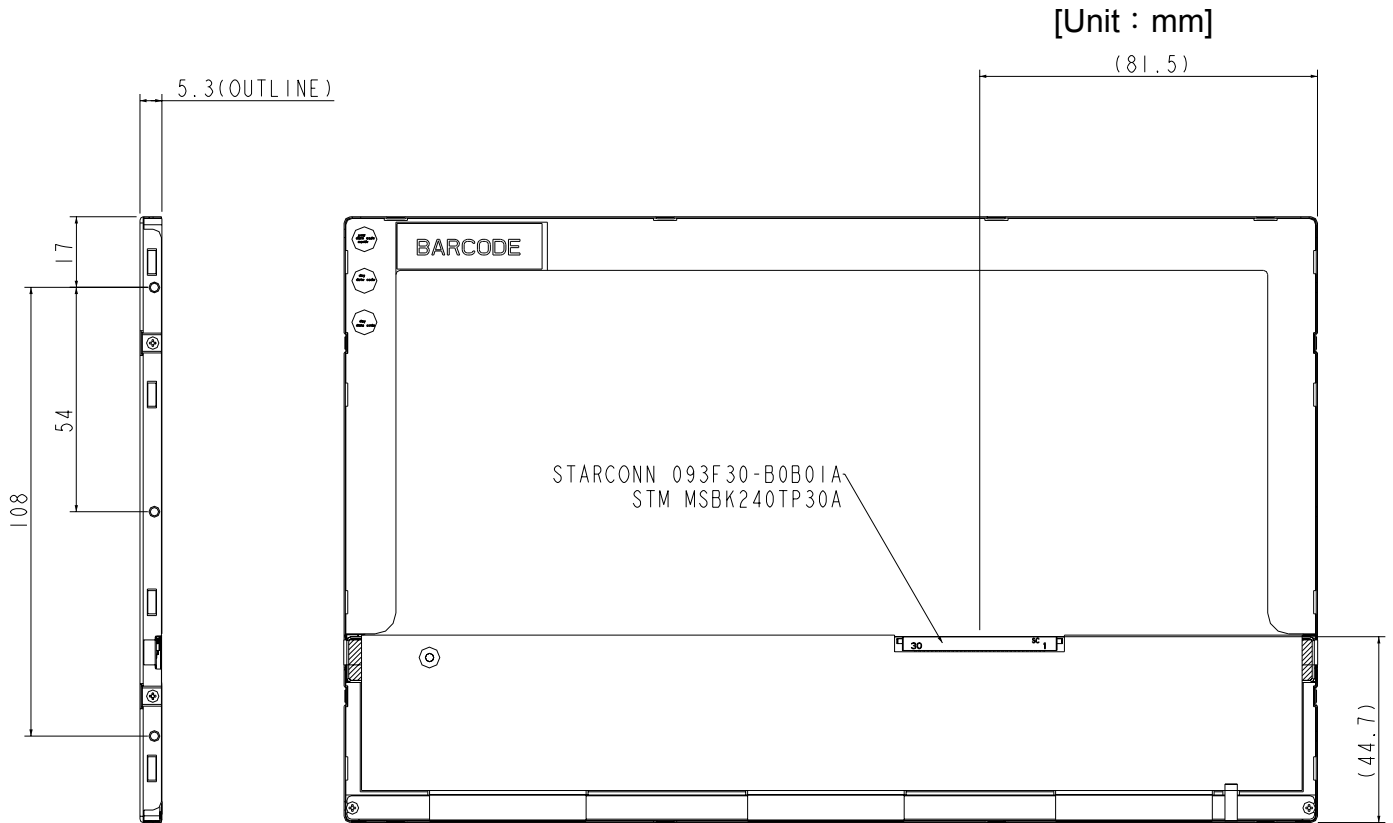

### NOTES:

1. GENERAL TOLERANCE:  $\pm 0.3$ mm.
2. ALLOWED DEPTH OF USERHOLE SCREW INSERTION IS 1.5mm MAX.
3. USERHOLE SCREW OF TORQUE=2.5 kgf/cm MAX.

[Note] : Tolerance is  $\pm 0.3$ mm unless noted

## 8. OPTICAL CHARACTERISTICS

Ta = 25°C, V<sub>CC</sub> = 3.3V

ITEM		SYMBOL	CONDITION	MIN.	TYP.	MAX.	UNIT	NOTE
Constrast Ratio		CR	Point-5	320	400	--	--	*1)*2)*3)
Luminance*)		Lw	Point-5	200	220	--	cd/m <sup>2</sup>	*1)*3)
Luminance Uniformity		ΔL		70	80		%	*1)*3)
Response Time (White - Black)		Tr+ Tf	Point-5	--	20	30	ms	*1)*3)*5)
Viewing Angle	Horizontal	ψ	CR ≥ 10 Point-5	110	140	--	°	*1)*2)*4)
	Vertical	θ		100	120	--	°	*1)*2)*4)
Color Coordinate	White	Wx Wy	θ = φ = 0° Point-5	0.273 0.289	0.313 0.329	0.353 0.369	--	*1)*3)
	Red	Rx Ry		TBD	TBD	TBD		
	Green	Gx Gy		TBD	TBD	TBD		
	Blue	Bx By		TBD	TBD	TBD		

NOTE :

\*1) Measure condition : 25°C ± 2°C , 60 ± 10%RH , under 10 Lux in the dark room. BM-5A (TOPCON) , viewing angle 2° , V<sub>CC</sub> = 3.3V , V<sub>LED</sub> = 5V.

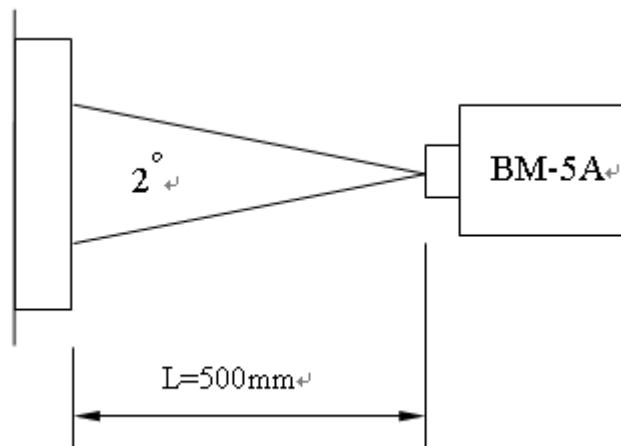

\*2) Definition of contrast ratio :

Contrast Ratio (CR) = (White) Luminance of ON ÷ (Black) Luminance of OFF



- 3) Definition of luminance : Measure white luminance on the point 5 as figure8-1  
 Definition of Luminance Uniformity: Measure white luminance on the point1~9 as figure8-1  

$$\Delta L = [L(\text{MIN})/L(\text{MAX})] \times 100$$

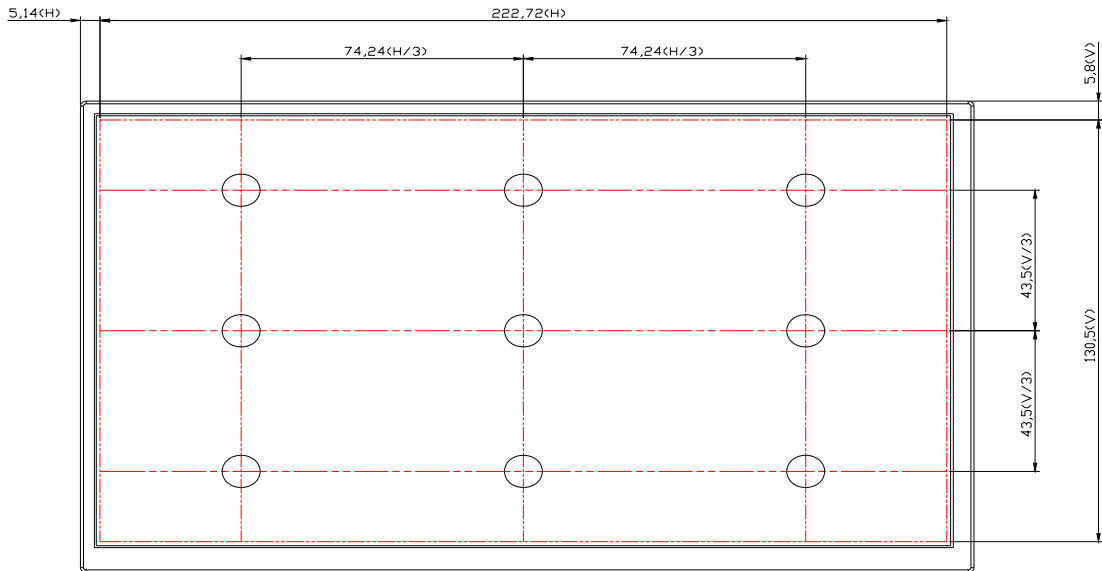

Fig8-1 Measuring point

- \*4) Definition of Viewing Angle( $\theta, \psi$ ), refer to Fig8-2 as below :  
 These items are measured by EZ-CONTRAST (ELDIM) in the dark room. (no ambient light).

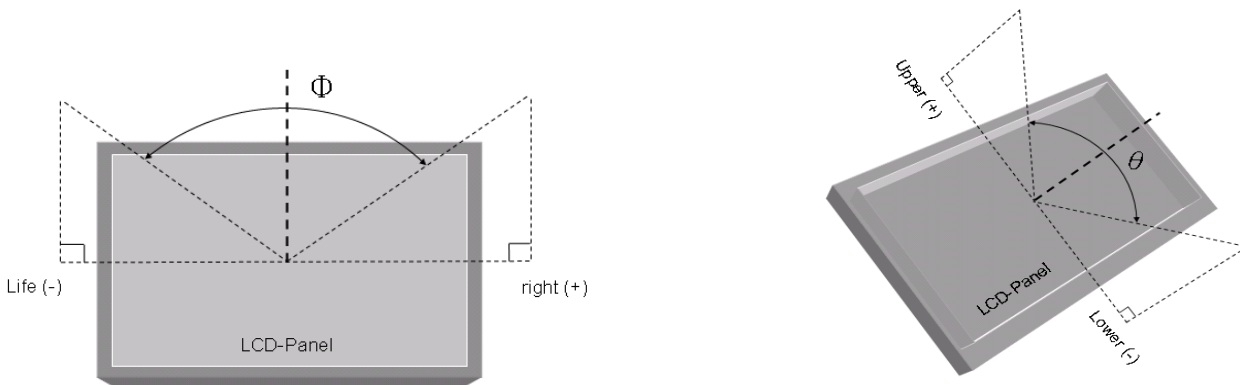

Fig8-2 Definition of Viewing Angle

- \*5) Definition of Response Time.(White-Black)

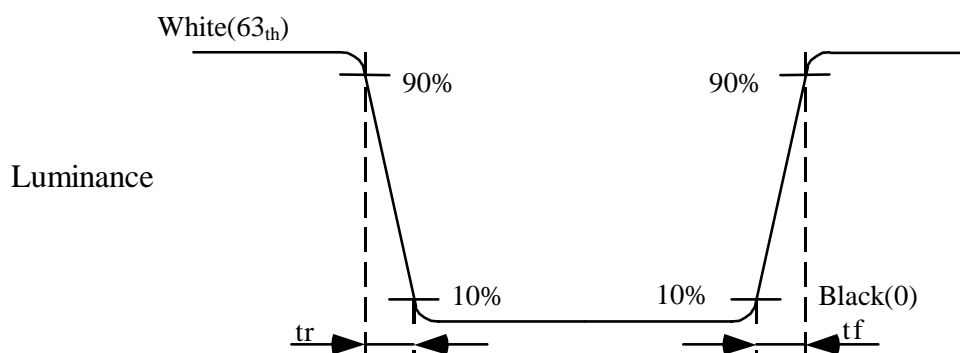

Fig8-3 Definition of Response Time(White-Black)

## 9. RELIABILITY TEST

### 9.1. Temperature and humidity

TEST ITEMS	CONDITIONS	NOTE
High Temperature Operation	70°C , 240Hrs	
High Temperature Storage	80°C , 240Hrs	
High Temperature High Humidity Operation	60°C , 90%RH , 240Hrs	No condensation
Low Temperature Operation	-20°C , 240Hrs	
Low Temperature Storage	-30°C , 240Hrs	
Thermal Shock	-30°C (0.5Hr) ~ 80°C(0.5Hr) 200 cycles	

### 9.2. Shock and Vibration

TEST ITEMS	CONDITIONS
Shock (Non-operation)	<ul style="list-style-type: none"> <li>● Shock level:980m/s<sup>2</sup>(equal to 100G)</li> <li>● Waveform:half sinusoidal wave,6ms.</li> <li>● Number of shocks:one shock input in each direction of three mutually perpendicular axes for a total of three shock inputs.</li> </ul>
Vibration (Non-operation)	<ul style="list-style-type: none"> <li>● Frequency range:8~33.3Hz</li> <li>● Stroke:1.3mm</li> <li>● Vibration:sinusoidal wave,perpendicularaxis(both x, z axis:2Hrs, y axis 4Hrs).</li> <li>● Sweep:2.9G,33.3Hz-400Hz</li> <li>● Cycle:15min</li> </ul>

### 9.3. ESD Test

ITEM	CONDITION	NOTE
ESD	150pF , 330Ω , ±8KV&±15KV air & contact test	*1)
	200pF , 0Ω , ±250V contact test	*2)

NOTE:

\*1) LCD glass and metal bezel

\*2) IF connector pins

### 9.4 Judgment Standard

The Judgment of the above test should be made as follow:

Pass:Normal display image with no obvious non-uniformity and no line defect.Partial transformation of the module parts should be ignored.

Fail:No display image,obvious non-uniform,or line defect.

## 10. APPEXNDIX EDID CODE TABLE

Byte#	Field Name and Comments	Value	Value
(Hex)		(Hex)	(Binary)
0		0	0000 0000
1		FF	11111111
2		FF	11111111
3		FF	11111111
4		FF	11111111
5		FF	11111111
6		FF	11111111
7		0	00000000
8	EISA manufacturer code = CPT (1st byte)	0E	00001110
9	(2nd byte)	14	00010100
0A	Product code LSB =	F6	11110110
0B	Product code MSB = (CLAA102NA0BCW=1270=0x4F6)	4	00000100
0C	ID (32-bit) serial number (preferred, but optional, zero if not used)	0	00000000
0D		0	00000000
0E		0	00000000
0F		0	00000000
10	Week of manufacture (preferred, but optional, zero if not used)	30	00110000
11	Year of manufacture (preferred, but optional, zero if not used)	12	00010010
12	EDID Structure version # = 1	1	00000001
13	EDID Revision # = 3	3	00000011
14	Video input definition (Digital I/P, non TMDS CRGB)	80	10000000
15	Max H image size (23.5) (rounded to cm)	17	00010111
16	Max V image size (14.58) (rounded to cm)	E	00001110
17	Display gamma =2.2 (=gamma*100)-100)	78	01111000
18	Features (no DPMS, Active off, RGB, timing BLK1)	0A	0000 1100
19	Red/Green low Bits (紅色為解碼器計算)	50	01010000
1A	Blue/White Low Bits	75	01110101
1B	Red X Rx = 0.571 bits 9→2	92	10010010
1C	Red Y Ry = 0.345 bits 9→2	58	01011000
1D	Green X Gx = 0.336 bits 9→2	56	01010110
1E	Green Y Gy = 0.57 bits 9→2	92	10010010
1F	Blue X Bx = 0.153 bits 9→2	27	00100111
20	Blue Y By = 0.124 bits 9→2	1F	00011111
21	White X Wx = 0.313 bits 9→2	50	01010000
22	White Y Wy = 0.329 bits 9→2	54	01010100
23	Established Timing I	0	00000000
24	Established Timing II	0	00000000
25	Manufacturer's Timings not used	0	00000000
26	Standard Timing Identification 1 not used	1	00000001
27	Standard Timing Identification 1 not used	1	00000001

28	Standard Timing Identification 2 not used	1	00000001
29	Standard Timing Identification 2 not used	1	00000001
2A	Standard Timing Identification 3 not used	1	00000001
2B	Standard Timing Identification 3 not used	1	00000001
2C	Standard Timing Identification 4 not used	1	00000001
2D	Standard Timing Identification 4 not used	1	00000001
2E	Standard Timing Identification 5 not used	1	00000001
2F	Standard Timing Identification 5 not used	1	00000001
30	Standard Timing Identification 6 not used	1	00000001
31	Standard Timing Identification 6 not used	1	00000001
32	Standard Timing Identification 7 not used	1	00000001
33	Standard Timing Identification 7 not used	1	00000001
34	Standard Timing Identification 8 not used	1	00000001
35	Standard Timing Identification 8 not used	1	00000001
36	Pixel Clock 1200*625*60=45MHz (LSB)	94	10010100
37	Pixel Clock = 45MHz 1024 * 600 @60Hz (MSB)	11	00010001
38	Horizontal Active = 1024 pixels Notes2 (lower 8 bits)	0	00000000
39	Horizontal Blanking = 176 pixels (lower 8 bits)	B0	10110000
3A	Horizontal Active : Horizontal Blanking(thbp) (upper 4:4 bits)	40	01000000
3B	Vertical Avtive =600 lines	58	01011000
3C	Vertical Blanking(tvbp) = 25lines (DE Blanking min for DE-only panels) lines	19	00011001
3D	Vertical Active : Vertical Blanking(tvbp) (upper 4:4 bits)	20	00100000
3E	Horizontal Sync. Offset (thfp)= 48 pixels	30	00110000
3F	Horizontal Sync Pulse Width = 32 pixels(WHL)	20	00100000
40	Vertical Sync Offset (tvfp)= 3 lines,Sync Width(tWVL) = 6 lines	36	00110110
41	Horizontal Vertical Sync Offset/Width upper 2bits	0	00000000
42	Horizontal Image Size = 222.72mm (lower 8bits)	DE	11011110
43	Vertical Image Size = 130.5mm (lower 8bits)	82	10000010
44	Horizontal & Vertical Image Size (upper 4:4bits)	0	00000000
45	Horizontal Border = X (Zero for internal LCD)	0	00000000
46	Vertical Border = X (Zero for internal LCD)	0	00000000
47	Non-interlaced,Normal display,no stereo, Digital separate sync,H/V pol negatives	19	00011001
48	Flag	0	00000000
49	Flag	0	00000000
4A	Flag	0	00000000
4B	Data Type Tag: Descriptor Defined by Manufacture	0	00000000
4C	Flag	0	00000000
4D	value=HSPWmin/2 (pixel clks)WHL	0	00000000
4E	value=HSPWmax/2 (pixel clks)WHL	0	00000000
4F	value=Thbpmin/2 (pixel clks) (for DE-only timing also, with Thfp=0)	0	00000000
50	value=Thbpmax/2 (pixel clks) (for DE-only timing also, with Thfp=0)	0	00000000
51	value=VSPWmin/2 (line pulses)WVL	0	00000000

52	value=VSPWmax/2 (line pulses)WVL	0	00000000
53	value=Tvpbmin/2	0	00000000
54	value=Tvpbmax/2	0	00000000
55	Thpmin=value*2+HApixelClks (pixel clks) Note2	0	00000000
56	Thpmax=value*2+HApixelClks (pixel clks) Note2	0	00000000
57	Tvpmin=value*2+Valines (line pulses)	0	00000000
58	Tvpmax=value*2+Valines (line pulses)	0	00000000
59	Module revision	0	00000000
5A	Flag	0	00000000
5B	Flag	0	00000000
5C	Flag	0	00000000
5D	Data Type Tag: (Monitor) ASCII String	FE	11111110
5E	Flag	0	00000000
5F	"C",67	43	01000011
60	"P",80	50	01010000
61	"T",84	54	01010100
62		20	00100000
63		20	00100000
64		20	00100000
65		20	00100000
66		20	00100000
67		20	00100000
68		20	00100000
69		20	00100000
6A		20	00100000
6B	(if <13 char, then terminate with ASCII code 0Ah, and set remaining char = 20h)	20	00100000
6C	Flag	0	00000000
6D	Flag	0	00000000
6E	Flag	0	00000000
6F	Data Type Tag: (Monitor) ASCII String	FE	11111110
70	Flag	0	00000000
71	"C",67	43	01000011
72	"L",76	4C	01001100
73	"A",65	41	01000001
74	"A",65	41	01000001
75	"1",49	31	00110001
76	"0",48	30	00110000
77	"2",50	32	00110010
78	"N",78	4E	01001110
79	"A",65	41	01000001
7A	"0",48	30	00110000
7B	"B",66	42	01000010
7C	(if <13 char, then terminate with ASCII code 0Ah, and set remaining char = 20h)	20	00100000
7D	(if <13 char, then terminate with ASCII code 0Ah, and set remaining char = 20h)	20	00100000

7E	Extension Flag (# of optional 128-byte EDID extension blocks to follow, typ=0)	0	00000000
7F	Checksum (the 1-byte sum of all 128 bytes in this EDID block shall equal zero)	BF	00000100

Note : 1. Code 10(Hex) (Week of manufacture ) & Code 11(Hex) ( Year of manufacture ), they will change when the date of producing change .

Note : 2. Code 7F(Hex) (checksum), it will change when Note1 change .

