



# Chunghwa Picture Tubes, Ltd.

## Product Specification

To : Data Modul  
Date : 110325

**TFT LCD**  
**CLAA102NB01XV**

ACCEPTED BY : (V1.0)

APPROVED BY	CHECKED BY	PREPARED BY
張聖暉	李家銘	羅宇城

Prepared by :  
Product Planning Management Division  
Small & Medium TFT Product Business Unit  
**CHUNGHWA PICTURE TUBES, LTD.**

1127 Hopin Rd., Padeh, Taoyuan, Taiwan 334, R.O.C.  
TEL: +886-3-3675151 FAX: +886-3-377-3858

Doc.No:	SPEC_CLAA102NB01XV_V1.0_Data Modul_110325	Issue Date:	20101118
---------	---	-------------	----------

**REVISION STATUS**

Revision Notice	Description	Page	Rev. Date
Ver. 0.0	First revision (Tentative)	-	2010.01.26
Ver. 0.1	Revised Mechanical Dimension Revised Optical Measuring point	P.14/15 P.17	2010.02.02
	Revised Backlight parts & CN2 LED backlight Revised Mechanical Dimension & IL Value	P.9 P.11 P.14/15 P.16	
Ver. 0.2	Revised Mechanical Dimension	P.14 P.15	2010.03.01
Ver. 0.3	Revised Module Size (mm) & Mechanical Dimension	P.4 P.14 P.15	2010.03.09
Ver. 0.4	Revised Mechanical Dimension	P.14 P.15	2010.04.09
Ver. 0.5	Module weight and Note1 Backlight Unit Rear Side Note3/Note4	P.2,3 P.7,14	2010.06.04
	Power consumption and current consumption	P.2,5	
Ver. 1.0	<b>General Information</b> : Power consumption	P.4	2010.11.18
	ABSOLUTE MAXIMUM RATINGS	P.5	
	<b>ELECTRICAL CHARACTERISTICS</b> TFT LCD Power Voltage Test pattern from black to white Backlight Unit	P.6,7,8	
	Connector of interface connection	P.11	
	INPUT SIGNAL	P.12	
	Rear Side of MECHANICAL DIMENSION	P.15	
	OPTICAL CHARACTERISTICS	P.16	
	RELIABILITY TEST	P.18	

## CONTENTS

<b>1. OVERVIEW</b> .....	<b>4</b>
<b>2. ABSOLUTE MAXIMUM RATINGS</b> .....	<b>5</b>
<b>3. ELECTRICAL CHARACTERISTICS</b> .....	<b>6</b>
3.1 TFT LCD .....	6
3.2 TFT-LCD Current Consumption .....	7
3.3 Power · Signal sequence .....	8
3.4 Backlight Unit .....	9
Ta=25°C .....	9
<b>4. INTERFACE CONNECTION</b> .....	<b>10</b>
4.1 CN1 (Input Signal).....	10
4.2 CN2 (LED backlight) .....	11
<b>5. INPUT SIGNAL</b> .....	<b>12</b>
5.1 Timing Specification .....	12
5.2 Timing sequence(Timing chart).....	12
<b>6. MECHANICAL DIMENSION</b> .....	<b>14</b>
6.1 Front Side	[Unit : mm] ... 14
6.2 Rear Side .....	15
<b>7. OPTICAL CHARACTERISTICS</b> .....	<b>16</b>
<b>8. RELIABILITY TEST</b> .....	<b>18</b>
8.1. Temperature and humidity .....	18
8.2. Shock and Vibration .....	18
8.3. Electrostatic Discharge.....	18
8.4. Judgment Standard .....	18

## 1. OVERVIEW

CLAA102NB01XV is 10.2" color TFT-LCD (Thin Film Transistor Liquid Crystal Display) module composed of LCD panel, driver ICs, control circuit and LED backlight. By applying 1024×600 images are displayed on the 10.2" diagonal screen. Display 16.2M colors by R.G.B signal input.

General specification are summarized in the following table:

ITEM	SPECIFICATION
Display Area (mm)	222.72(H) x 130.5(V) (10.2-inch diagonal)
Number of Pixels	1024(H) × 3(RGB) × 600(V)
Pixel Pitch (mm)	0.2175 (H) × 0.2175 (V)
Color Pixel Arrangement	RGB vertical stripe
Display Mode	Normally Black
Number of Colors	16.2M
Brightness (cd/m <sup>2</sup> )	400 (typ)
Response Time (ms)	30 (typ)
NTSC ratio (%)	60 (Typ)
Viewing Angle ( CR ≥ 10)	160 degree (Horizontal.)
	160 degree (Vertical)
Power Consumption (W)	3.74W
Interface connection	LVDS
Module Size (mm)	235(W) x147(H)x 4.5(D)-Without Component
	235(W) x147(H)x 5.1(D)-With Component
Module Weight (g)	295
Backlight Unit	LED
Surface Treatment	Anti-Glare

## 2. ABSOLUTE MAXIMUM RATINGS

The following are maximum values which, if exceeded, may cause faulty operation or damage to the unit.

Item	Symbol	Min.	Max.	Unit	Note
Digital Supply Voltage	VDD VDD_LVDS	-0.3	5	V	
Analog Supply Voltage	AVDD	-0.5	15	V	
Gate On Voltage	VGH	-0.3	40	V	
Gate Off Voltage	VGL	-20	0.3	V	
Gate On-Gate Off Voltage	VGH-VGL	-0.3	40	V	
Signal Input Voltage	NIN0 ~ NIN2 PIN0 ~ PIN2 NINC,PINC	-0.5	5		
Forward Current(per LED)	I <sub>f</sub>		35	mA	
Reverse Voltage(per LED)	V <sub>R</sub>		5	V	
Pulse Forward Current(per LED)	I <sub>fp</sub>		100	mA	【Note 1】

【Note1】 I<sub>fp</sub> Conditions : Duty ≤ 1/10 @ Pulse Width ≤ 10msec

【Note2】 Each LED operating must under the condition as below drawing.  
(Ambient Temperature /Allowable Forward Current)

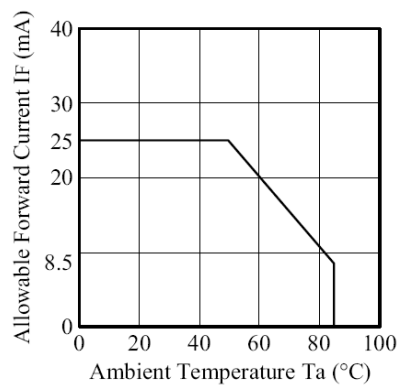

### 3. ELECTRICAL CHARACTERISTICS

#### 3.1 TFT LCD

Item	Symbol	Min.	Typ.	Max.	Unit.	Note.
Digital Supply Voltage	VDD VDD_LVDS	3	3.3	3.6	V	
Logic signal input voltage (LVDS: NIN,PIN)	VCM	$\frac{ VID }{2}$	-	$2.4 - \frac{ VID }{2}$	V	【Note1】
	VID	200	-	600	mV	【Note1】
	VTH	-	-	100	mV	VCM=1.2V 【Note1】
	VTL	-100	-	-	mV	【Note1】
Analog Supply Voltage	AVDD	12.8	13	13.2	V	
Gate On Voltage	VGH	17	18	19	V	
Gate Off Voltage	VGL	-6.6	-6	-5.4	V	
Common Voltage	VCOM	5.0	5.2	5.4	V	【Note2】
Gamma voltage	V1		11.52		V	
	V2		10.82		V	
	V3		9.63		V	
	V4		9.07		V	
	V5		8.66		V	
	V6		7.66		V	
	V7		7.26		V	
	V8		5.05		V	
	V9		4.65		V	
	V10		3.63		V	
	V11		3.20		V	
	V12		2.61		V	
	V13		1.41		V	
	V14		0.7		V	

Ta=25°C

Remarks :

【Note1】

LVDS signal

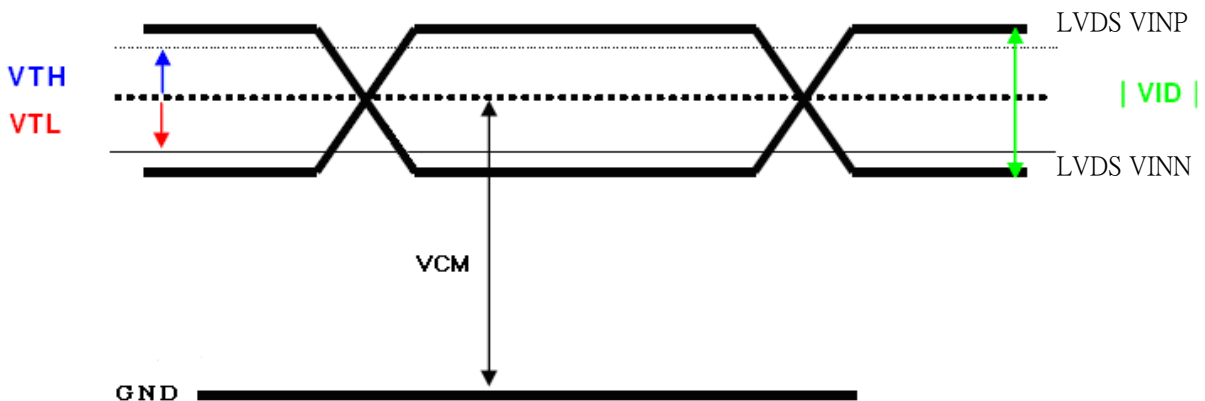

【Note2】 Please adjust VCOM to make the flicker level be minimum.

## 3.2 TFT-LCD Current Consumption

Item	Symbol	Min	Type	Max	Unit	Notes	Item
Gate on power current	IVGH	VGH = 18V	-	0.5	1	mA	【Note1】
Gate off power current	IVGL	VGL = -6V	-	0.5	1	mA	【Note1】
Digital power current	IVDD	VDD = 3.3V	-	40	50	mA	【Note1】
Analog power current	IAVDD	AVDD = 13V	-	40	50	mA	【Note1】
Total Power Consumption	PC		-	664	839	mW	【Note1】

## 【Note1】

Typical: Under 256 gray pattern

Maximum: Under black pattern



Gray pattern

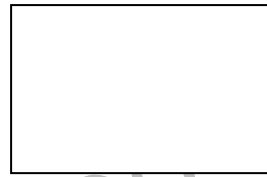

White Pattern

### 3.3 Power · Signal sequence

Power On : VDD→AVDD/VGL →VGH →Video &Logic Signal

Power Off : Video &Logic Signal→ VGH→AVDD/VGL→VDD

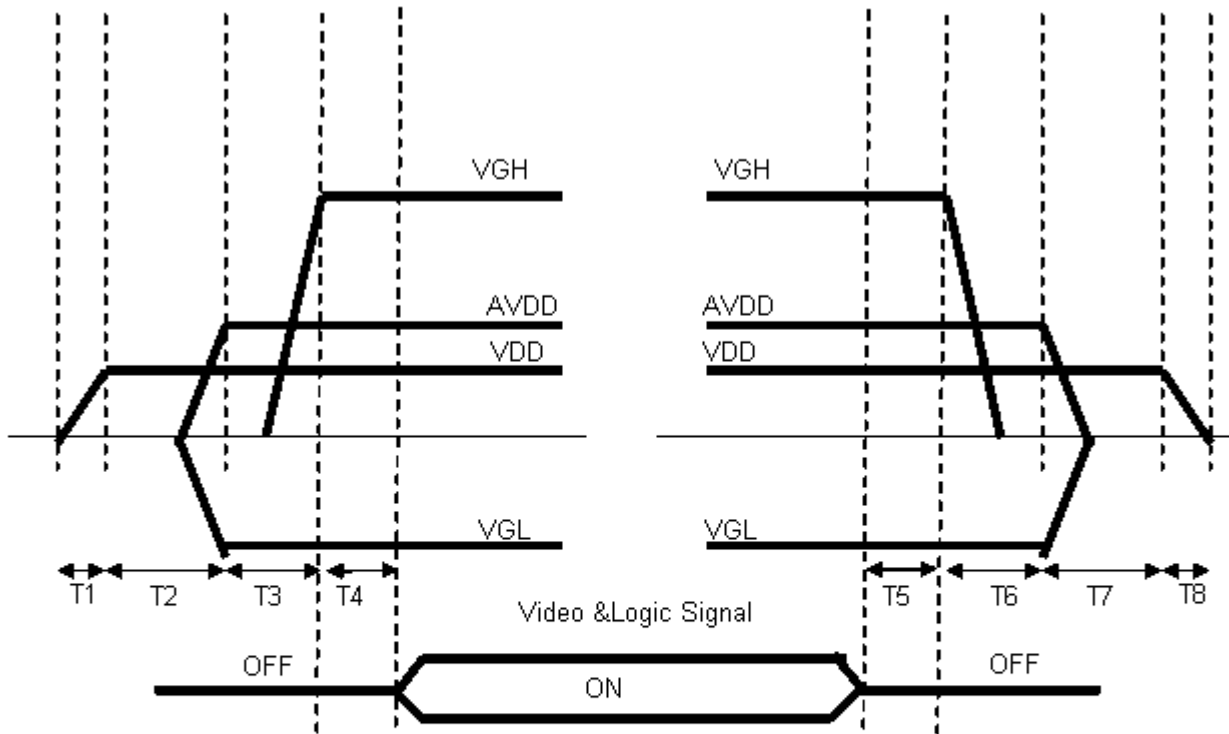

$0 < T1 \leq 10\text{ms}$   
 $20\text{ms} < T2$   
 $10\text{ms} < T3$   
 $0 < T4 \leq 10\text{ms}$

$0 < T5 \leq 10\text{ms}$   
 $0 < T6$   
 $0 < T7$   
 $0 < T8$

Data M/C



## 3.4 Backlight Unit

Ta=25°C

ITEM	SYMBOL	CONDITION	MIN	TYP	MAX	UNIT	NOTE
LED current	IL	Ta=25°C (21mA/serise)	-	240	-	mA	
LED voltage	VL	Ta=25°C (21mA/serise)	10.864	12.8	14.42	V	
Power consumption	WL	Ta=25°C (21mA/serise)	-	3.072	-	W	
LED Lifetime	-	Ta=25°C IF=21mA	30000			Hr	
		Ta=60°C IF=21mA	15000			Hr	

Remarks :

\*1) LED Circuit Diagram :

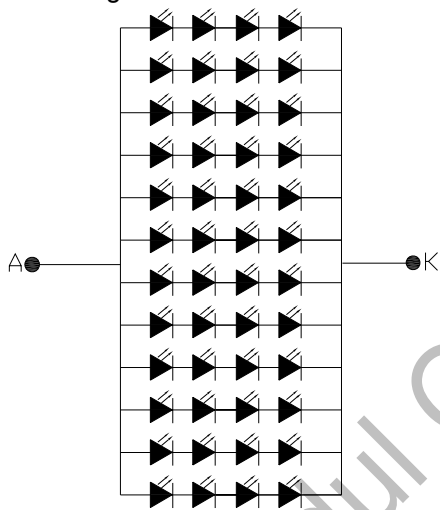

\*2) A : Anode(+), K : Cathode(-)

\*3) LED control suggested fixed current, or it may cause the abnormal phenomenon of lighting-up.

\*4) Definition of the LED lifetime : Luminance(L) under 50% of initial value.

## 4. INTERFACE CONNECTION

### 4.1 CN1 (Input Signal)

Pin NO.	SYMBOL	DESCRIPTION
1	AGND	Analog ground
2	AVDD	Analog power
3	VDD	Digital power
4	GND	Digital ground
5	VCOM	Common voltage
6	VDD	Digital power
7	GND	Digital ground
8	V14	Gamma correction voltage reference
9	V13	Gamma correction voltage reference
10	V12	Gamma correction voltage reference
11	V11	Gamma correction voltage reference
12	V10	Gamma correction voltage reference
13	V9	Gamma correction voltage reference
14	V8	Gamma correction voltage reference
15	GND	Digital ground
16	VDD_LVDS	LVDS power
17	GND	Digital ground
18	PIND3	Positive LVDS differential data inputs
19	NIND3	Negative LVDS differential data inputs
20	GND	Digital ground
21	PINC	Positive LVDS differential clock inputs
22	NINC	Negative LVDS differential clock inputs
23	GND	Digital ground
24	PIND2	Positive LVDS differential data inputs
25	NIND2	Negative LVDS differential data inputs
26	GND	Digital ground
27	PIND1	Positive LVDS differential data inputs
28	NIND1	Negative LVDS differential data inputs
29	GND	Digital ground
30	PIND0	Positive LVDS differential data inputs
31	NIND0	Negative LVDS differential data inputs
32	GND	Digital ground
33	GND_LVDS	LVDS ground
34	GRB	Global reset pin. Active low to enter reset state. Suggest to connecting with an RC reset circuit for stability. Normally pull high. (R=10KΩ · C=0.1μF)
35	STBYB	Standby mode, normally pull high STBYB="1", normal operation STBYB="0", timing control, source driver will turn off, all output are high-Z
36	SHLR	Left or right display control
37	VDD	Digital power
38	UPDN	Up / down display control
39	AGND	Analog ground
40	AVDD	Analog power
41	VCOM	Common voltage
42	DITH	Dithering function enable control. Normally pull low DITHER = "1", Enable internal dithering function DITHER = "0", Disable internal dithering function
43	NBW	Please pull high for normally black display
44	VDD	Digital Power
45	GND	Digital ground
46	V7	Gamma correction voltage reference
47	V6	Gamma correction voltage reference
48	V5	Gamma correction voltage reference
49	V4	Gamma correction voltage reference
50	V3	Gamma correction voltage reference
51	V2	Gamma correction voltage reference
52	V1	Gamma correction voltage reference

53	GND	Digital ground
54	VDD	Digital power
55	GND	Digital ground
56	VGH	Positive power for TFT
57	VDD	Digital power for Gate IC
58	VGL	Negative power for TFT
59	GND	Digital ground for Gate IC
60	NC	Not connect

**Remarks :**

- 1) Mating connector : 089K60-000100-G2-R (STARCONN)
- 2) GND Pin must connection to ground.
- 3) NC Pin keep not connect to GND or other signal pin.
- 4) UPDN and SHLR control Function

UPDN	SHLR	FUNCTION
0	1	Normal display
0	0	Select left or right
1	1	Shift up or down control
1	0	Select left or right Shift up or down control

- 5) NBW setting

Display Type	NBW
Normally black display	1
Normally white display	0

## 4.2 CN2 (LED backlight)

Pin No.	SYMBOL	FUNCTION
1	A	Anode
2	K	Cathode

Note :

Input connector : BHSR-02VS-1(JST)

Outlet connector: SM02B-BHSS-1(JST)

### 5. INPUT SIGNAL

#### 5.1 Timing Specification

Item			Symbol	Min	Typ	Max	Unit	
LVDS input signal sequence	CLK Frequency		tclk	45	51.2	57	MHz	
LCD input signal sequence (Input LVDS Transmitter)	DENA	Horizontal	Horizontal total Time	t <sub>H</sub>	1324	1344	1364	tCLK
			Horizontal effective Time	t <sub>HA</sub>	1024			tCLK
			Horizontal Blank Time	t <sub>HB</sub>	300	320	340	tCLK
	Vertical	Vertical total Time	t <sub>V</sub>	625	635	645	t <sub>H</sub>	
		Vertical effective Time	t <sub>VA</sub>	600			t <sub>H</sub>	
		Vertical Blank Time	t <sub>VB</sub>	25	35	45	t <sub>H</sub>	

#### 5.2 Timing sequence(Timing chart)

##### 5.2.1 Horizontal Timing Sequence

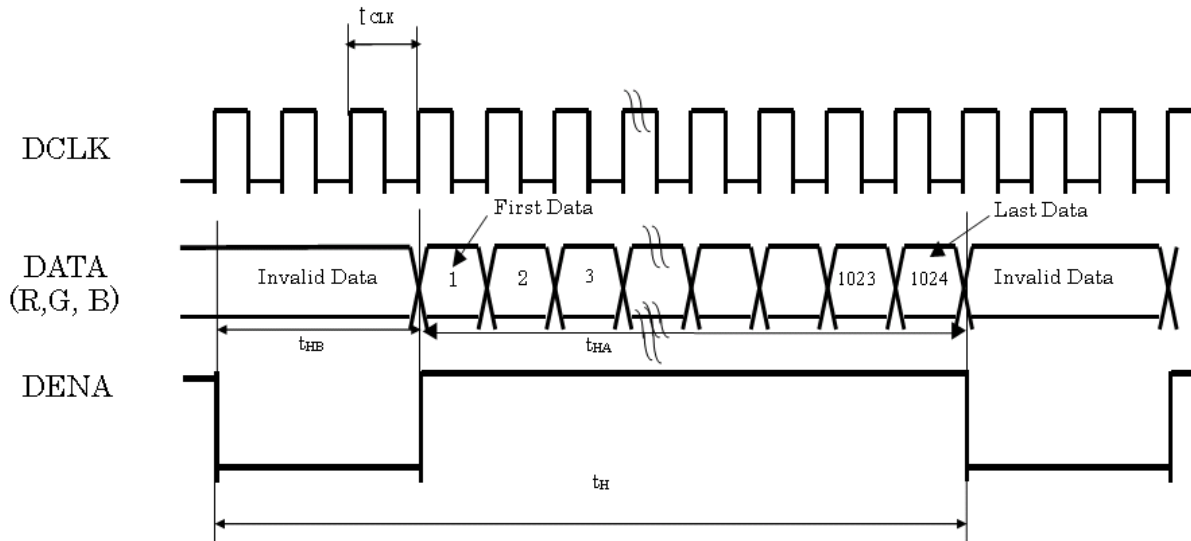

### 5.2.2 Vertical Timing Sequence

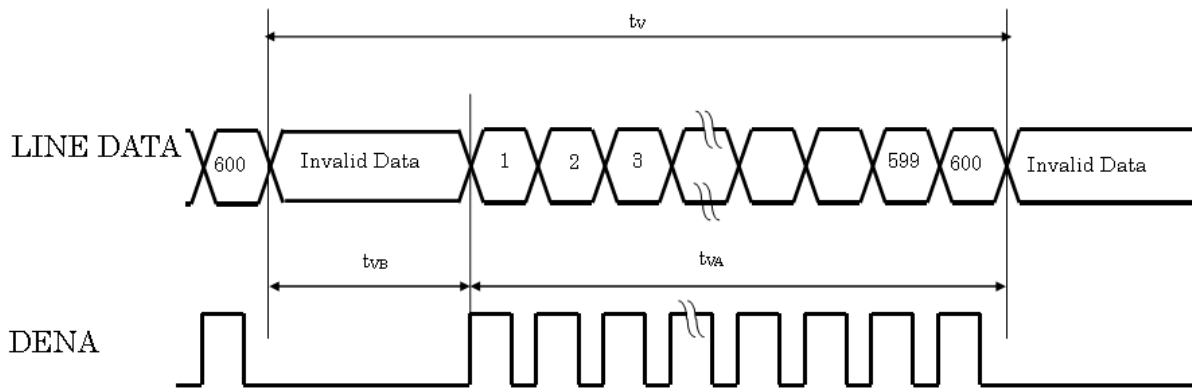

### 5.2.3 LVDS Input Data mapping

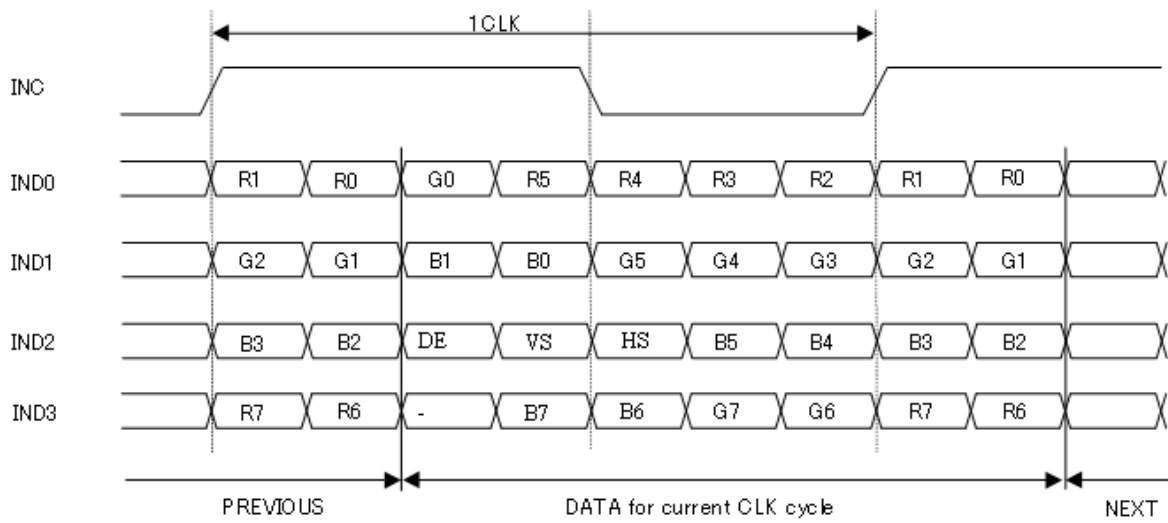

### 6. MECHANICAL DIMENSION

#### 6.1 Front Side

[Unit : mm]

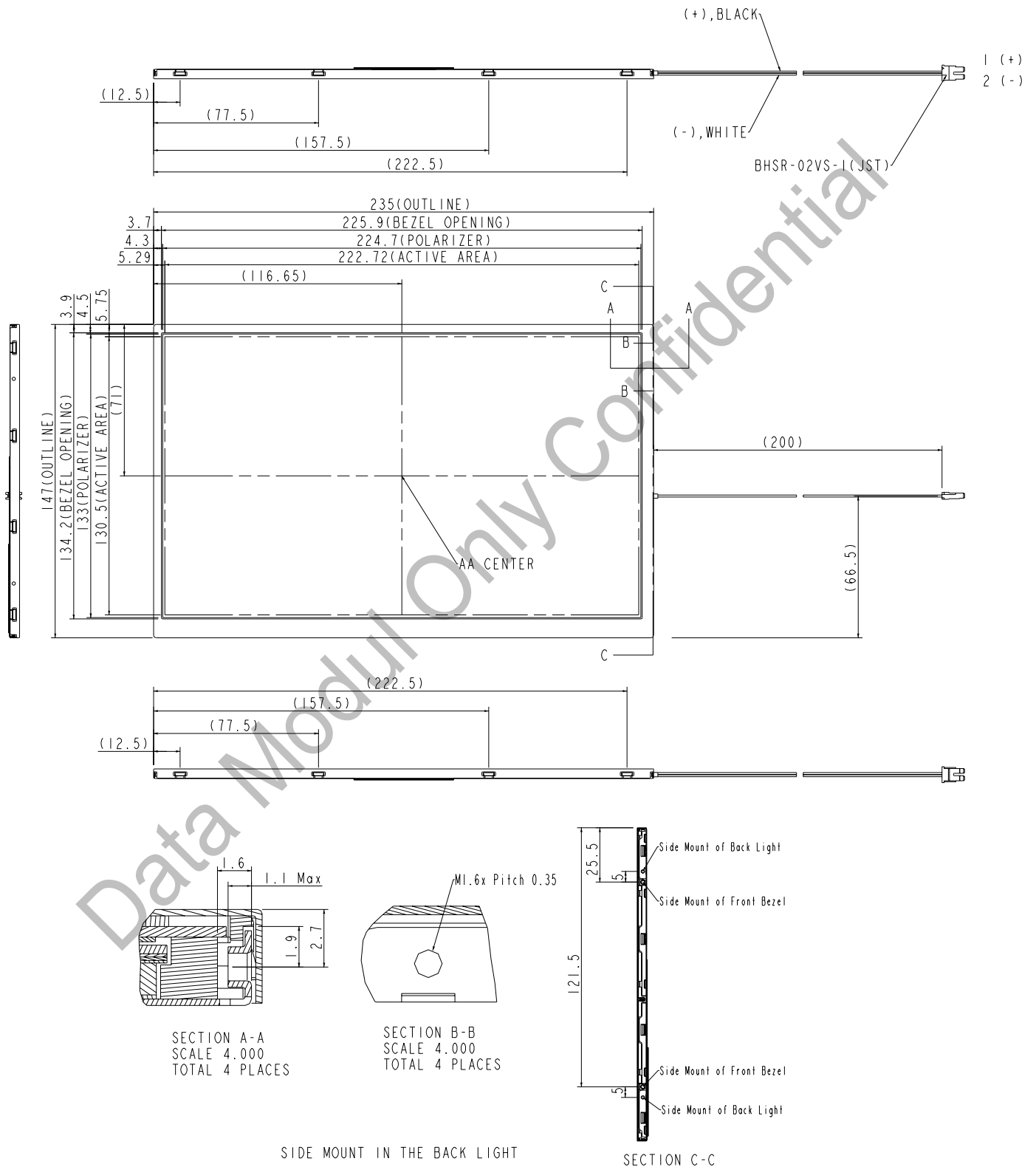

6.2 Rear Side

[Unit : mm]

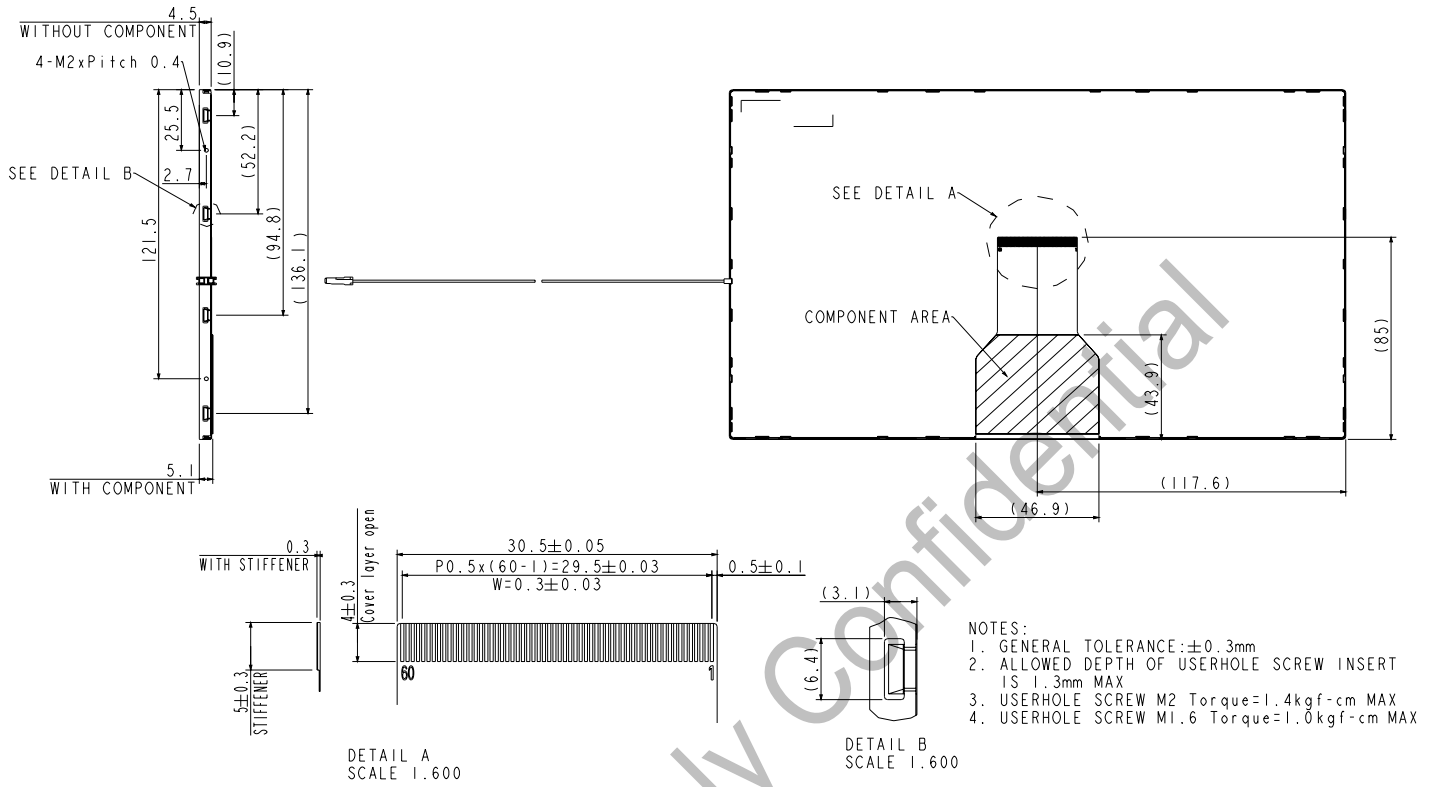

Data Modul Only Confidential

## 7. OPTICAL CHARACTERISTICS

Ta = 25°C, VCC=3.3V

ITEM	SYMBOL	CONDITION	MIN.	TYP.	MAX.	UNIT	Remarks	
Contrast Ratio	CR	Point-5		700		--	*1)*2)*3)	
Luminance	Center	Lw	320	400		cd/m <sup>2</sup>	*1)*3)	
	Uniformity	ΔL	70	80		%	*1)*3)	
Response Time (White - Black)	Tr +Tf	Point-5		30	35	ms	*1)*3)*5)	
NTSC	-	Point-5		60		%	*1)*3)	
Viewing Angle	Horizontal		CR ≥ 10	140	160		°	*1)*2)*4)
	Vertical		Point-5	140	160		°	*1)*2)*4)
color coordinate	White	Wx Wy	Point-5	0.273 0.296	0.313 0.336	0.353 0.376	--	*1)*3)
	Red	Rx Ry		0.610 0.294	0.650 0.334	0.690 0.374		
	Green	Gx Gy		0.300 0.557	0.340 0.597	0.380 0.637		
	Blue	Bx By		0.112 0.045	0.152 0.085	0.192 0.125		

Remarks :

\*1) Measure condition : 25°C ± 2°C , 60 ± 10% RH , under 10 Lux in the dark room. BM-5A (TOPCON) , viewing angle 2° , IL=240 mA ( Backlight current ) , measurement after lighting on 10 mins.

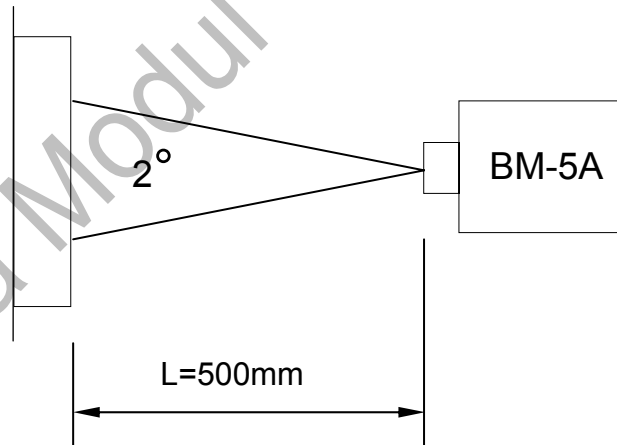

\*2) Definition of contrast ratio :

Contrast Ratio (CR) = (White) Luminance of ON ÷ (Black) Luminance of OFF



- 3) Definition of luminance : Measure white luminance on the point 5 as figure.7-1  
 Definition of Luminance Uniformity: Measure white luminance on the point1~9 as figure.7-1  
 $\Delta L = [L(\text{MIN})/L(\text{MAX})] \times 100$

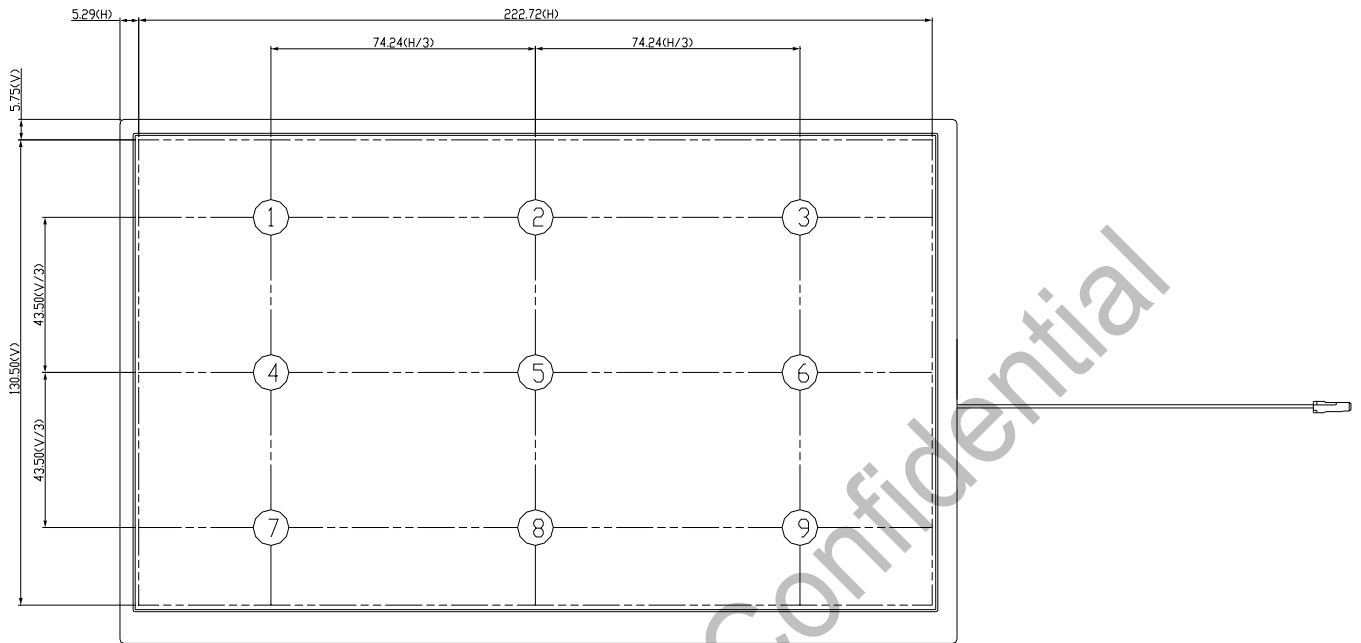

Fig.7-1 Measuring point

- \*4) Definition of Viewing Angle( $\theta, \psi$ ), refer to Fig.7-2 as below :

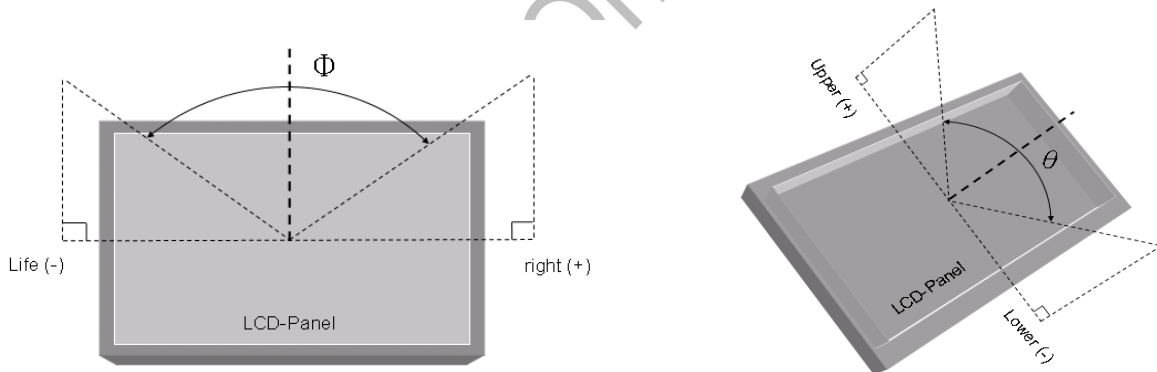

Fig.7-2 Definition of Viewing Angle

- \*5) Definition of Response Time.(White-Black)

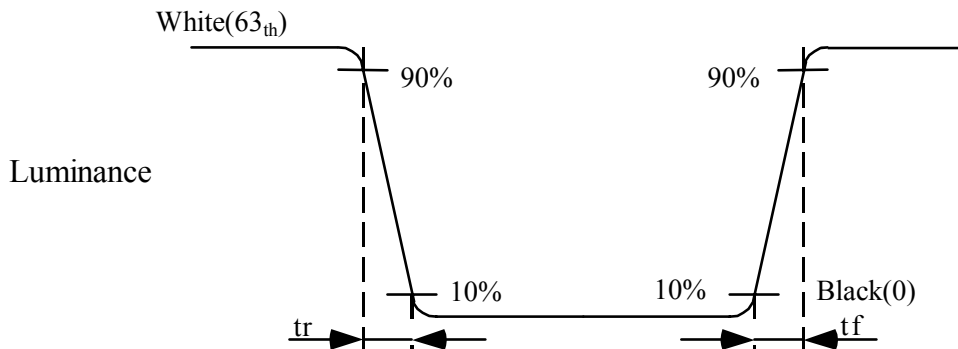

Fig.7-3 Definition of Response Time(White-Black)

## 8. RELIABILITY TEST

### 8.1. Temperature and humidity

TEST ITEMS	CONDITIONS	REMARK
High Temperature Operation	70° C , 240 Hrs	
High Temperature Storage	80° C ,240Hrs	
High Temperature High Humidity Operation	60° C , 90% RH, 240Hrs	No condensation
Low Temperature Operation	-20° C , 240 Hrs	
Low Temperature Storage	-30° C ,240Hrs	
Thermal Shock	-30° C (0.5 hr)~80° C (0.5 hr), 200 CYCLE	

### 8.2. Shock and Vibration

TEST ITEMS	CONDITIONS
Shock (Non-operation)	<ul style="list-style-type: none"> <li>● Shock level: 980m/s<sup>2</sup>(equal to 100G).</li> <li>● Waveform: half sinusoidal wave,6ms.</li> <li>● Number of shocks: one shock input in each direction of three mutually perpendicular axes for a total of three shock inputs.</li> </ul>
Vibration (Non-operation)	<ul style="list-style-type: none"> <li>● Frequency range:8~33.3Hz</li> <li>● Stoke : 1.3 mm</li> <li>● Vibration: sinusoidal wave, perpendicular axis(both x, y,z axis: 2Hrs).</li> <li>● Sweep: 2.9G,33.3 Hz -400 Hz</li> <li>● Cycle: 15 min</li> </ul>

### 8.3. Electrostatic Discharge

TEST ITEM	CONDITIONS
ESD	[MM] 200pF, 0Ω, ±200V, once for each terminal [HM] 150pF, 330Ω, ±8 & 15kV, 25 times/point, 4points/panel(Air mode) [HM] 150pF, 330Ω, ±8 & 15kV,25 times/point(Contact mode)

### 8.4. Judgment Standard

The judgment of the above test should be made as follow:

Pass: Normal display image with no obvious non-uniformity and no line defect.

Partial transformation of the module parts should be ignored.

Fail: No display image, obvious non-uniformity, or line defects.